



HomeTek Technology Inc.

ADDRESS: No. 67-9, Shir Men Road, Tu Cheng City,  
Taipei Hsien, Taiwan, R. O. C.  
PHONE : 886-2-22608375 FAX : 886-2-22748013  
E - mail : hometek@ms15.hinet.net



# EMI TEST REPORT FOR

APPLICANT : SMART CABLING & TRANSMISSION CORP.  
ADDRESS : 3F., No. 4, Lane 130, Min-Chung Rd.,  
Hsin-Tien City, Taipei Hsien, Taiwan, R. O. C.  
EUT : Video Distributor & Amplifier  
MODEL NO. : CD102XX



## MEASUREMENT PROCEDURE USED

AS/NZS CISPR 13: 2003 Sound and television broadcast receivers and associated equipment - Radio disturbance characteristics – Limits and methods of measurement

### PREPARED BY :

HomeTek Technology Inc.

No. 67-9, Shir Men Road, Tu Cheng City,

Taipei Hsien. Taiwan, R. O. C.

Report # : AS3C033



<b>TABLE OF CONTENTS.....</b>	<b>2</b>
<b>GENERAL INFORMATION.....</b>	<b>4</b>
<b>MODIFICATION LIST.....</b>	<b>6</b>
<b>CONDUCTED POWER LINE TEST.....</b>	<b>7</b>
1    TEST INSTRUMENTS & FACILITIES .....	7
2    TEST PROCEDURE.....	7
3    TEST SETUP .....	8
4    CONFIGURATION OF THE EUT.....	10
5    EUT OPERATING CONDITION.....	14
6    LIMIT OF CONDUCTED POWER LINE EMISSION .....	14
7    RESULT OF CONDUCTED POWER LINE TEST .....	14
<b>RADIATED EMISSION TEST.....</b>	<b>19</b>
1    TEST PROCEDURE.....	19
2    RESULT OF RADIATED EMISSION TEST .....	19
<b>DISTURBANCE VOLTAGE AT THE ANTENNA TERMINALS TEST.....</b>	<b>20</b>
1    TEST PROCEDURE.....	20
2    RESULT OF DISTURBANCE VOLTAGE AT THE ANTENNA TERMINALS TEST.....	20
<b>CLAMP EMISSION TEST.....</b>	<b>21</b>
1    TEST INSTRUMENTS & FACILITIES .....	21
2    TEST PROCEDURE.....	22
3    TEST SETUP .....	23
4    CONFIGURATION OF THE EUT.....	24
5    EUT OPERATING CONDITION.....	24
6    LIMIT OF CLAMP EMISSION TEST :.....	24
7    RESULT OF CLAMP EMISSION TEST.....	24
<b>APPENDIX A</b>	
PHOTOS OF TEST CONFIGURATION	
<b>APPENDIX B</b>	
PHOTOS OF EUT	



ADDRESS: No. 67-9, Shir Men Road, Tu Cheng City,  
 Taipei Hsien, Taiwan, R. O. C.  
 PHONE : 886-2-22608375 FAX : 886-2-22748013  
 E - mail : hometek@ms15.hinet.net



APPLICANT : SMART CABLING & TRANSMISSION CORP.  
 ADDRESS : 3F., No. 4, Lane 130, Min-Chung Rd.,  
Hsin-Tien City, Taipei Hsien, Taiwan, R. O. C.  
 Receipt Date : 03/18/2004 Final Test Date: 03/24/2004  
 EUT : Video Distributor & Amplifier  
 MODEL NO. : CD102XX

MEASUREMENT PROCEDURE USED :

AS/NZS CISPR 13: 2003 Sound and television broadcast receivers and associated equipment - Radio disturbance characteristics - Limits and methods of measurement

- THE MAXIMUM EMISSION LEVELS WERE COMPARED TO THE CISPR 13 LIMITS BOTH RADIATED AND CONDUCTED EMISSION.
- THE ABOVE DEVICE WAS TESTED BY HOMETEK TECHNOLOGY INC. TO SHOWS THE MAXIMUM EMISSION LEVEL FROM THE DEVICE.
- THIS TEST RESULTS OF THIS REPORT APPLIES TO ABOVE TESTED SAMPLE ONLY.
- THIS TEST REPORT SHALL NOT BE REPRODUCE IN PART WITHOUT WRITTEN APPROVAL OF HOMETEK TECHNOLOGY INC.
- THE REPORT MUST NOT BE USED BY THE CLIENT TO CLAIM PRODUCT ENDORSEMENT BY NVLAP OR ANY AGENCY OF THE U. S. GOVERNMENT.
- THE TEST RESULTS ARE TRACEABLE TO THE NATIONAL OR INTERNATIONAL STANDARD.

PREPARED BY : Frankie DATE : 3/30/2004  
 FRANKIE WANG  
 CHECK BY : Albert Tsai DATE : 3/30/2004  
 ALBERT TSAI / Senior Engineer  
 APPROVED BY : Tommy Rau DATE : 3/30/2004  
 TOMMY RAU / Manager



### GENERAL INFORMATION

- 1 APPLICANT : SMART CABLING & TRANSMISSION CORP.
- 2 ADDRESS : 3F., No. 4, Lane 130, Min-Chung Rd.,  
Hsin-Tien City, Taipei Hsien, Taiwan, R. O. C.
- 3 MANUFACTURER : SMART CABLING & TRANSMISSION CORP.
- 4 ADDRESS : 3F., No. 4, Lane 130, Min-Chung Rd.,  
Hsin-Tien City, Taipei Hsien, Taiwan, R. O. C.
- 5 DESCRIPTION OF EUT :
  - EUT : Video Distributor & Amplifier
  - Model Number : CD102XX
  - Serial # : N/A

5.1 The difference between series of models CD102XX is shown as below:

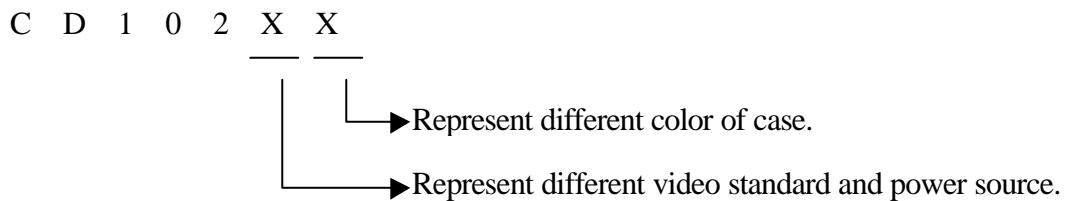

The worst case of EMI test model is CD102 and the final test data were shown in this test report.



## 6 FEATURES OF EUT :

### **Model No. CD102**

6.1	Video Input Channel	1
6.2	Video Output Channel	2
6.3	Video Input Level	0.8~1.2Vp-p, 75ohms
6.4	Video Output Level	1Vp-p (Standard), 75ohms
6.5	Video Bandwidth	10Hz ~ 10MHz
6.6	Power Supply	DC 12V
6.7	Power Consumption	100mA
6.8	Material	ABS Black



HomeTek Technology Inc.

## **MODIFICATION LIST**

THE FOLLOWING ACCESSORIES WERE ADDED TO THE EUT DURING TESTING :

NO MODIFICATION BY HOMETEK TECHNOLOGY INC.

## CONDUCTED POWER LINE TEST

### 1 TEST INSTRUMENTS & FACILITIES

The following test Instruments was used during the conducted test :

Item	Instruments/ Facilities	Specification	Manufacturer	Model # S/N	Date Of Cal.
1	EMI Receiver	9KHz ~ 30MHz	ROHDE & SCHWARZ	ESHS 30 844827/007	MAR/2004
2	LISN (for EUT)	50 /50uH/100A 150KHz ~ 30MHz	SCHWARZ BECK	NNLK 8121 8121370	OCT/2003
3	LISN (for Support Unit)	50 /50uH/10A 9KHz ~ 30MHz	ROHDE & SCHWARZ	ESH3-Z5 846128/007	FEB/2004
4	Terminator	50	N/A	N/A	NOV/2003
5	Attenuation	50 /10dB	Mini-Circuit	NAT-10 AT-002	JUL/2003
6	Cable	3m	SUHNER	RG-223 CON2-001	DEC/2003
7	ESXS-K1 (software)	Version 2.03b 9KHz ~ 30MHz	ROHDE & SCHWARZ	1082.9678.02 840.913/246	N/A

Note : Items 1 ~ 6 were calibrated within period of 1 year.

### 2 TEST PROCEDURE

- 2.1 The EUT was tested according to **AS/NZS CISPR 13**.
- 2.2 The EUT was placed 0.4 meter from the conducting wall of shielding room and kept at least 0.8 meter from any other grounded conducting surface.
- 2.3 The frequency range form 0.15 MHz to 30 MHz was investigated.
- 2.4 The LISN used was 50 Ohm / 50 uHenry as specified of **AS/NZS CISPR 13**.
- 2.5 All the support peripherals are connect to the other LISN.
- 2.6 Cables and peripherals were moved to find the maximum emission levels for each frequency.

### 3 TEST SETUP

#### 3.1 Typical : Setup Of Conducted Test

ELECTRICAL AND ELECTRONIC EQUIPMENT IN THE RANGE OF 9kHz TO 40 GHz AS/NZS CISPR 13

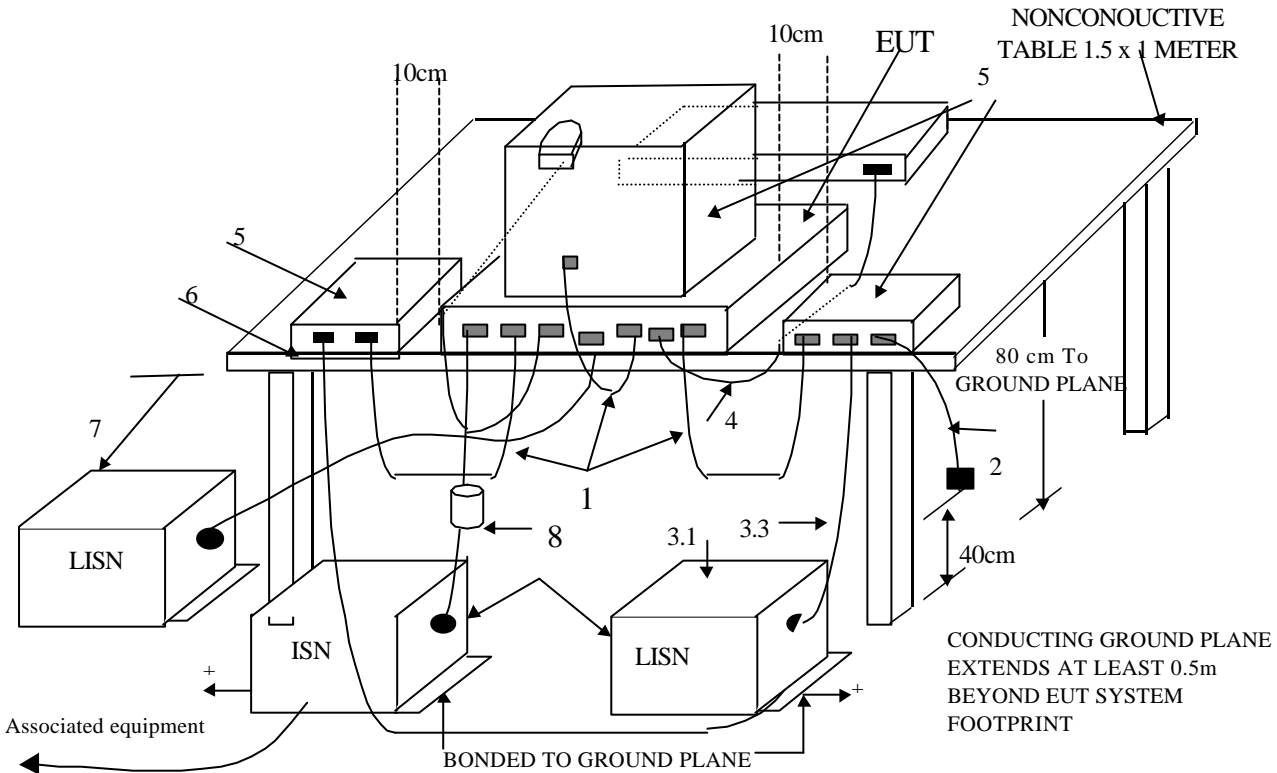

+LISNs may have to be moved to the side to meet 3.3 below.

(Details for setup configuration, please refer to appendix A.)

#### LEGEND:

1. If cables, which hang closer than 40 cm to the horizontal metal groundplane, cannot be shortened to appropriate length, the excess shall be folded back and forth forming a bundle 30 cm to 40 cm long.
2. Excess mains cord shall be bundled in the centre or shortened to appropriate length.
3. EUT is connected to one artificial mains network (AMN). All AMNs and ISNs may alternatively be connected to a vertical reference plane or metal wall.
  - 3.1 All other units of a system are powered from a second AMN. A multiple outlet strip can be used for multiple mains cords.
  - 3.2 AMN and ISN are 80 cm from the EUT and at least 80 cm from other units and other metal planes.
  - 3.3 Mains cords and signal cables shall be positioned for their entire lengths, as far as possible, at 40 cm from the vertical reference plane.
4. Cables of hand-operated devices, such as keyboards, mice, etc., have to be placed as close as for normal usage.
5. Peripherals shall be placed at a distance of 10 cm from each other and from the controller, except for the monitor which, if this is an acceptable installation practice, shall be placed directly on the top of the controller.
6. I/O signal cable intended for external connection.
7. The end of the I/O signal cables which are not connected to an AE may be terminated, if required, using correct terminating impedance.
8. If used, the current probe shall be placed at 0.1 m from the ISN.

#### Test Configuration Tabletop Equipment Conducted Emission

### 3.2 Block Diagram Of Conducted Test

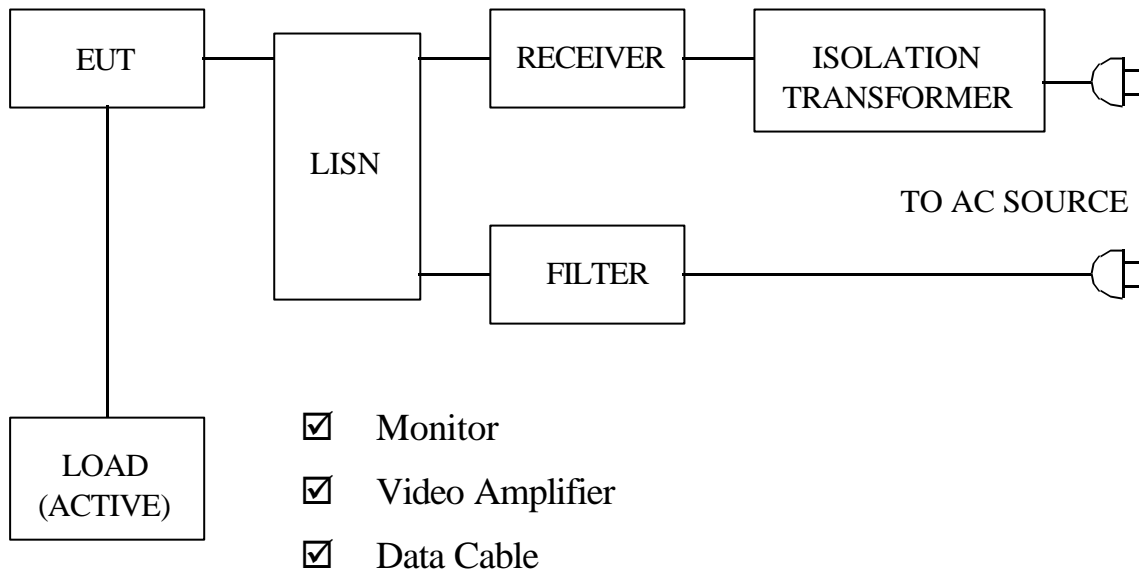

#### 4 CONFIGURATION OF THE EUT

The EUT was configured according to **AS/NZS CISPR 13**. All I/O ports were connected to the appropriate peripherals. All peripherals and cables are listed below (including internal device) :

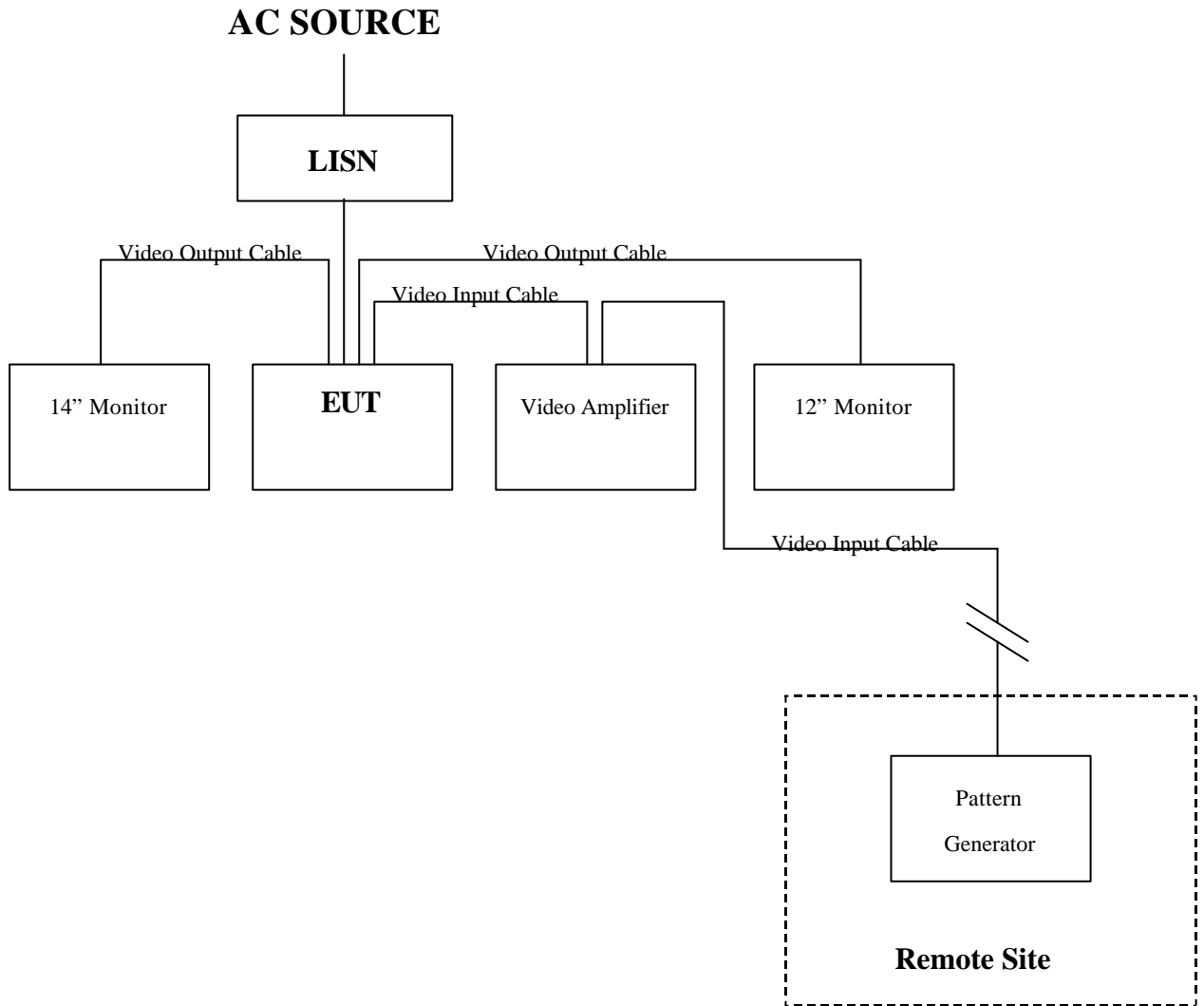

Figure 1



4.1 EUT

EUT Type : Proto Type Engineer Type Mass Production  
Condition when received : Good Damage : \_\_\_\_\_  
Device : Video Distributor & Amplifier  
Applicant : SMART CABLING & TRANSMISSION CORP.  
Manufacturer : SMART CABLING & TRANSMISSION CORP.  
Model Number : CD102XX  
Serial Number : N/A  
FCC ID : N/A  
Data Cable1 (Video Input) : Shielded, 1.8 m, Metal Type  
Data Cable2 (Video Input) : Shielded, 10 m, Metal Type  
Data Cable3 (Video Output) : Shielded, 1.8 m, Metal Type  
Power Cord (AC) Adapter : 2 pin  
Power Cord (DC) Adapter : Un-Shielded, 1.9 m, 2 pin  
Power Supply Type : Linear Adapter

4.2 PERIPHERALS

14" Monitor

Manufacturer : YOKO  
Model Number : YK-8111  
Serial Number : N/A  
FCC ID : N/A  
Data Cable : Shielded, 1.8 m  
Power Cord : Un-Shielded, 1.8 m



12" Monitor

Manufacturer : YOKO  
Model Number : YK-8102  
Serial Number : N/A  
FCC ID : N/A  
Data Cable : Shielded, 1.8 m  
Power Cord : Un-Shielded, 1.8 m

Video Amplifier

Manufacturer : SMART CABLING  
Model Number : CA101  
Serial Number : N/A  
FCC ID : N/A  
Data Cable : Shielded, 1.8 m  
Power Cord : Un-Shielded, 1.9 m

Power Adapter

Manufacturer : JELEC  
Model Number : YAD-1200500E  
Serial Number : N/A  
FCC ID : N/A  
Data Cable : N/A  
Power Cord : Un-Shielded, 1.9 m



Pattern Generator (Remote Site)

Manufacturer : LEADER  
Model Number : 408  
Serial Number : 3037775  
FCC ID : FCC DoC  
Data Cable : Shielded  
Power Cord : Un-Shielded, 1.8 m

4.3 REMARK : N/A

## 5 EUT OPERATING CONDITION

- 5.1 The operation frequency of the EUT is 10Hz ~ 10MHz.
- 5.2 Configure the EUT according to the **AS/NZS CISPR 13**.
- 5.3 Turn on all the power of EUT and peripheral.
- 5.4 Remote pattern generator send 1KHz audio and color bar signal to EUT.
- 5.5 The photos of conducted test configuration, please refer to appendix A.**

## 6 LIMIT OF CONDUCTED POWER LINE EMISSION

Frequency Range	Quasi Peak	Average
0.15 ~ 0.5 MHz	66 - 56 dBuV	56 - 46 dBuV
0.5 ~ 5 MHz	56 dBuV	46 dBuV
5 ~ 30 MHz	60 dBuV	50 dBuV

- 6.1 In the above table, the tighter limit applies at the band edges.

## 7 RESULT OF CONDUCTED POWER LINE TEST

- 7.1 The frequency range from 0.15 MHz to 30 MHz was investigated. All readings are quasi-peak values and average.
- 7.2 IF bandwidth : 9 kHz, Meas Time : 1 sec.
- 7.3 Temperature : 27 , Humidity : 60 % RH.
- 7.4 Uncertainty in conducted emission measurement :  $\pm 3.87\text{dB}$ .
- 7.5 The conducted test result were gained by following procedures :  
 Level = Reading Level + Insertion Loss of LISN + Cable Loss  
 (All calculation were done by ESHS30 EMI test receiver.)
- 7.6 Result : **PASSED**



HomeTek EMC LAB. TEL :886-2-22608375

27 Mar 2004 14:41

CONDUCTED EMISSIONS

EUT: Video Distributor & Amplifier  
Manuf: 3C033  
Op Cond: LINE 1  
Operator: TIM  
Test Spec: FOR CISPR13  
Comment: 240V/50Hz  
CD102  
Result File: 3c03311g.dat : CD102

Prescan Measurement: Detectors: X PK / + AV  
Meas Time: see scan settings  
Subranges: 16  
Acc Margin: 55 dB

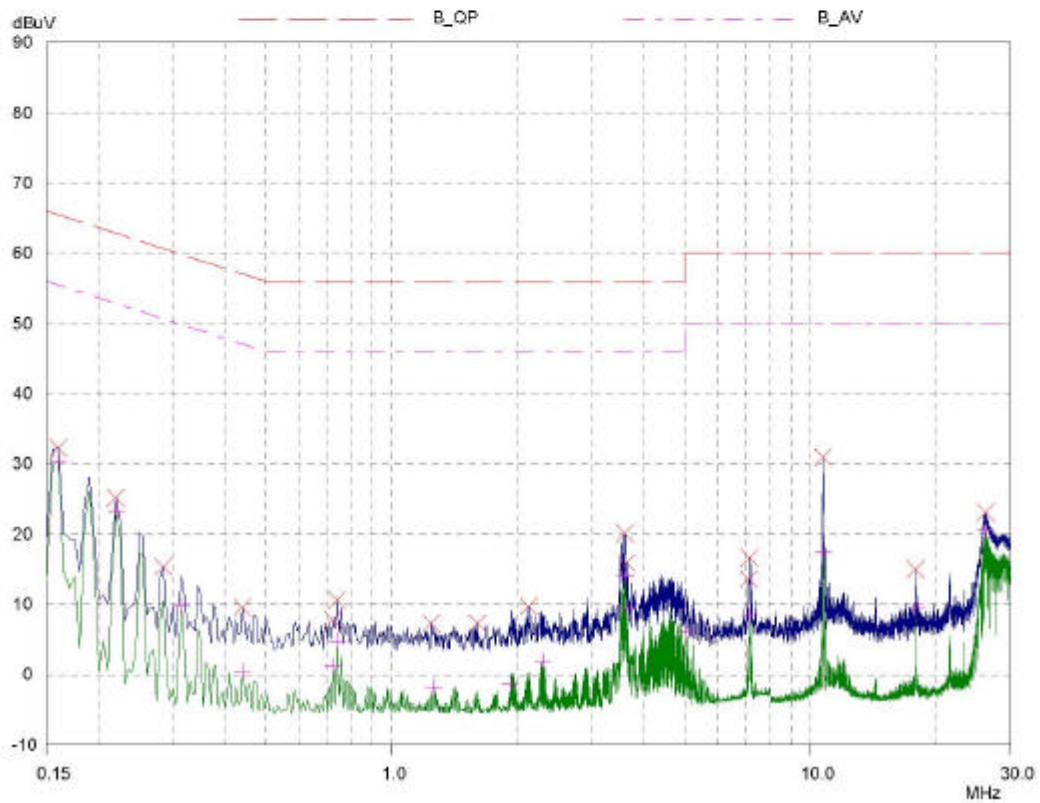



HomeTek EMC LAB. TEL :886-2-22608375  
CONDUCTED EMISSIONS

27 Mar 2004 14:41

EUT: Video Distributor & Amplifier  
Manuf: 3C033  
Op Cond: LINE 1  
Operator: TIM  
Test Spec: FOR CISPR13  
Comment: 240V/50Hz  
CD102  
Result File: 3c03311g.dat : CD102

Prescan Measurement: Detectors: X PK / + AV  
Meas Time: see scan settings  
Subranges: 16  
Acc Margin: 55 dB

Peak Search Results

Frequency MHz	PK Level dBuV	PK Limit dBuV	PK Delta dB
0.16	32.28	65.46	33.18
0.22	25.17	62.82	37.65
0.285	15.38	60.67	45.29
0.44	9.55	57.06	47.51
0.725	7.81	56.00	48.19
0.74	10.64	56.00	45.36
1.245	7.32	56.00	48.68
1.605	7.34	56.00	48.66
2.125	9.68	56.00	46.32
3.61	20.11	56.00	35.89
3.64	15.88	56.00	40.12
7.13	13.55	60.00	46.45
7.16	16.60	60.00	43.40
10.71	30.93	60.00	29.07
17.87	15.02	60.00	44.98
28.23	23.05	60.00	36.95

Frequency MHz	AV Level dBuV	AV Limit dBuV	AV Delta dB
0.16	30.37	55.46	25.09
0.22	23.35	52.82	29.47
0.315	9.77	49.84	40.07
0.44	0.43	47.06	46.63
0.725	1.20	46.00	44.80
0.74	4.73	46.00	41.27
1.28	-1.91	46.00	47.91
1.92	-1.36	46.00	47.36
2.3	1.82	46.00	44.18
3.61	13.97	46.00	32.03
3.645	9.50	46.00	36.50
5.05	6.13	50.00	43.87
7.16	8.47	50.00	41.53
10.74	17.46	50.00	32.54
17.89	9.62	50.00	40.38
28.15	20.52	50.00	29.48

\* limit exceeded



HomeTek EMC LAB. TEL :886-2-22608375

27 Mar 2004 14:47

CONDUCTED EMISSIONS

EUT: Video Distributor & Amplifier  
Manuf: 3C033  
Op Cond: LINE 2  
Operator: TIM  
Test Spec: FOR CISPR13  
Comment: 240V/50Hz  
CD102  
Result File: 3c03321g.dat : CD102

Prescan Measurement: Detectors: X PK / + AV  
Meas Time: see scan settings  
Subranges: 16  
Acc Margin: 55 dB

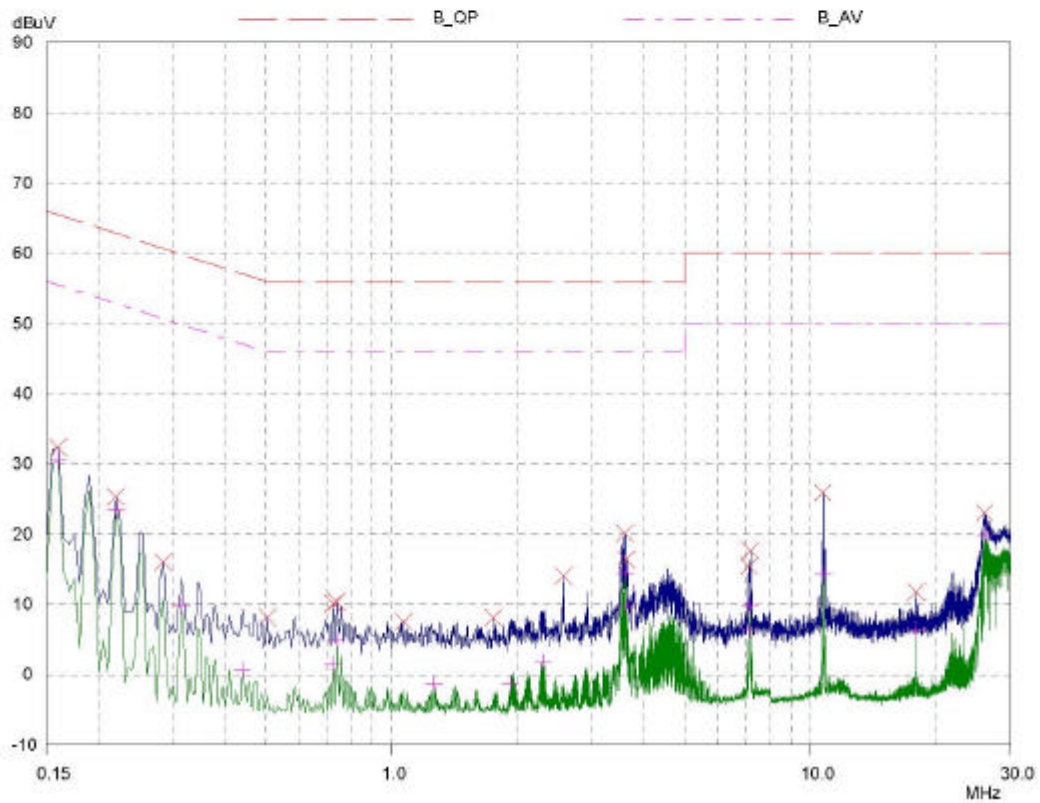



HomeTek EMC LAB. TEL :886-2-22608375  
CONDUCTED EMISSIONS

27 Mar 2004 14:47

EUT: Video Distributor & Amplifier  
Manuf: 3C033  
Op Cond: LINE 2  
Operator: TIM  
Test Spec: FOR CISPR13  
Comment: 240V/50Hz  
CD102  
Result File: 3c03321g.dat : CD102

Prescan Measurement: Detectors: X PK / + AV  
Meas Time: see scan settings  
Subranges: 16  
Acc Margin: 55 dB

Peak Search Results

Frequency MHz	PK Level dBuV	PK Limit dBuV	PK Delta dB
0.16	32.30	65.46	33.16
0.22	25.31	62.82	37.51
0.285	15.98	60.67	44.69
0.505	8.15	56.00	47.85
0.725	10.05	56.00	45.95
0.74	10.40	56.00	45.60
1.07	7.50	56.00	48.50
1.75	8.06	56.00	47.94
2.575	13.98	56.00	42.02
3.61	20.11	56.00	35.89
3.64	16.39	56.00	39.61
7.13	15.41	60.00	44.59
7.19	17.59	60.00	42.41
10.71	25.90	60.00	34.10
17.89	11.76	60.00	48.24
26.04	23.04	60.00	36.96

Frequency MHz	AV Level dBuV	AV Limit dBuV	AV Delta dB
0.16	30.47	55.46	24.99
0.22	23.40	52.82	29.42
0.315	9.77	49.84	40.07
0.44	0.60	47.06	46.46
0.725	1.43	46.00	44.57
0.74	4.84	46.00	41.16
1.26	-1.38	46.00	47.38
1.92	-1.31	46.00	47.31
2.3	1.69	46.00	44.31
3.61	14.48	46.00	31.52
3.645	9.62	46.00	36.38
7.14	6.22	50.00	43.78
7.16	9.84	50.00	40.16
10.74	14.35	50.00	35.65
17.89	6.30	50.00	43.70
26.15	19.93	50.00	30.07

\* limit exceeded



## **RADIATED EMISSION TEST**

### **1 TEST PROCEDURE**

According to **AS/NZS CISPR 13**.

### **2 RESULT OF RADIATED EMISSION TEST**

N/A (This standard is not applicable to this EUT ( Model : CD102)).



## **DISTURBANCE VOLTAGE AT THE ANTENNA TERMINALS TEST**

### **1 TEST PROCEDURE**

According to **AS/NZS CISPR 13**.

### **2 RESULT OF DISTURBANCE VOLTAGE AT THE ANTENNA TERMINALS TEST**

N/A (This standard is not applicable to this EUT ( Model : TPA016)).



## CLAMP EMISSION TEST

### 1 TEST INSTRUMENTS & FACILITIES

The following test Instruments was used during the radiated emission test :

Item	Instruments /facilities	Specification	Manufacturer	Model # / S/N#	Location	Date of Cal.
1	Clamp Test Site	30MHz ~ 300MHz/6m	HomeTek	Clamp #1	Clamp Test Site	N/A
2	EMI TEST RECEIVER	30MHz ~ 1GHz	ROHDE & SCHWARZ	ESVS10 845165/017	Clamp Test Site	SEP/2003
3	RF SPECTRUM ANALYZER	N/A	HEWLETT PACKARD	8591E 3710A06158	Clamp Test Site	MAY/2003
4	PRE-AMPLIFIER	100KHz ~ 1.3GHz	HP	8447D 1937A03120	Clamp Test Site	MAR/2004
5	ABSORBING CLAMP	30MHz ~ 300MHz	ROHED & SCHWARZ	MDS21 845061/004	Clamp Test Site	DEC/2003
6	EMI 32 (software)	N/A	AUDIX	19991013-0923		N/A

Note : Items 2 ~ 5 upon which need to calibrated are with period of 1 year.



## 2 TEST PROCEDURE

2.1 The EUT was test according to **AS/NZS CISPR 13**.

2.2 The disturbance power test was performed at HomeTek Lab' s CLAMP Test Site .

2.3 The frequency range from 30 MHz to 300 MHz, the measurement were made with absorbing clamp.

2.4 The EUT were investigated with all signal cables individually as below:

- Video Input toward EUT cable;
- Video Input toward support unit cable;
- Video output toward EUT cable;
- Video output toward support unit cable;
- AC power toward EUT cable;
- DC power toward EUT cable;
- DC power toward support unit cable

and the worst case of test data were shown in this test report.

### 3 TEST SETUP

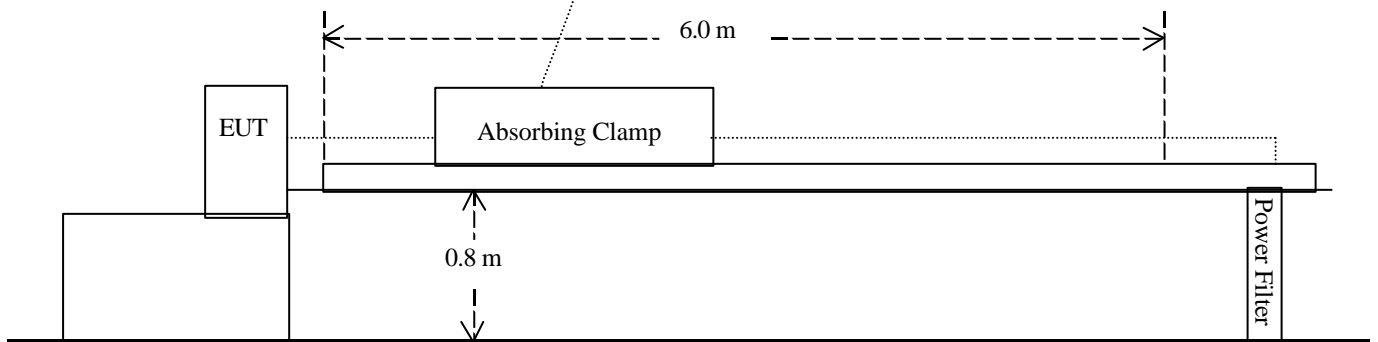
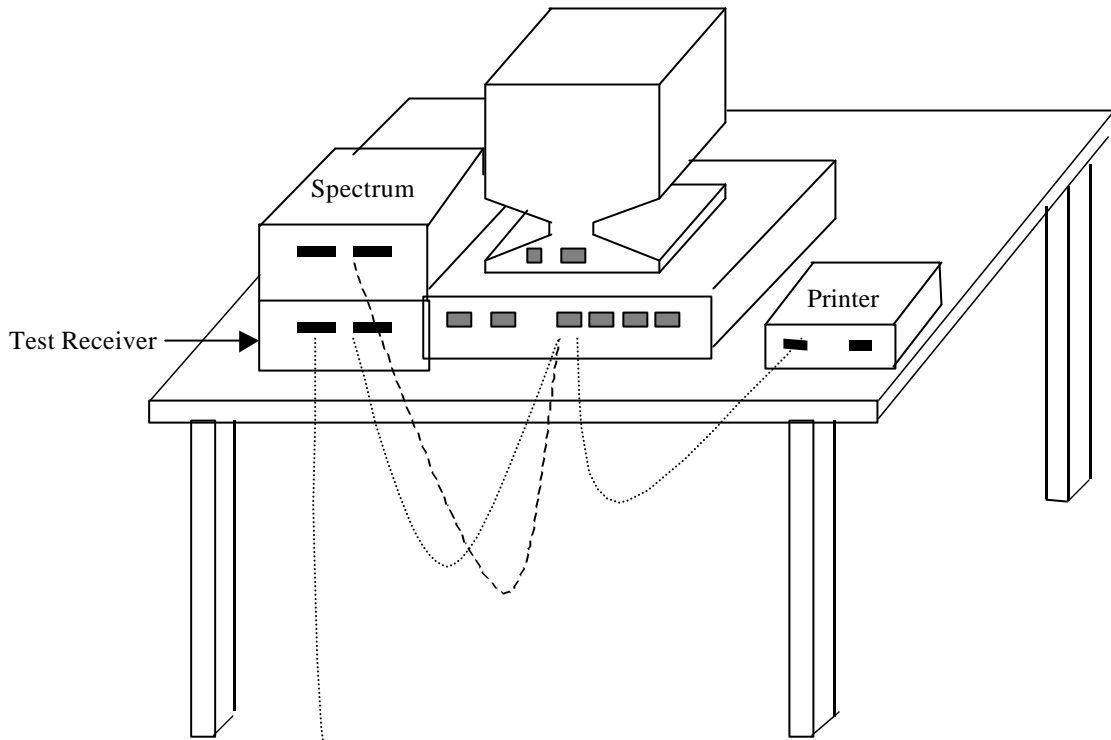

(Details for setup configuration, please refer to appendix A.)

AC Power

4 CONFIGURATION OF THE EUT

Same as “Conducted Power Line test”, section 4

5 EUT OPERATING CONDITION

5.1 Same as “Conducted Power Line test”, section 5

**5.2 The photos of clamp emission test configuration, please refer to appendix A.**

6 LIMIT OF CLAMP EMISSION TEST :

Frequency (MHz)	Limit Values (dBpW)	
	QP	AV
30 – 300	45 - 55	35 - 45
300 – 1000	N/A	N/A

7 RESULT OF CLAMP EMISSION TEST

7.1 The frequency range from 30 MHz to 300 MHz, the measurement were made with absorbing clamp.

7.2 The disturbance power test was performed at HomeTek Lab’ s CLAMP Test Site .

7.3 Temperature : 23 , Humidity : 55 % RH.

7.4 Test Mode : **Video Input toward EUT cable**

7.5 The clamp emission result were gained by the following method :

Level = Reading Level + Probe Factor (Antenna Factor) + Cable Loss – Preamp Factor

Over Limit = Level – Limit Line

7.6 The clamp mission test was passed at minimum margin :

90.48 MHz/ 28.43 dBuV/m, Antenna Height 2.0 Meter,

The Mode : Video Input toward EUT cable, Model : CD102.

7.7 Result : **PASSED**



HomeTek Technology Inc.



HomeTek Technology Inc.

**Appendix A**  
**PHOTOS OF TEST CONFIGURATION**

## PHOTO OF CONDUCTED POWER LINE TEST

Model : CD102



Front View

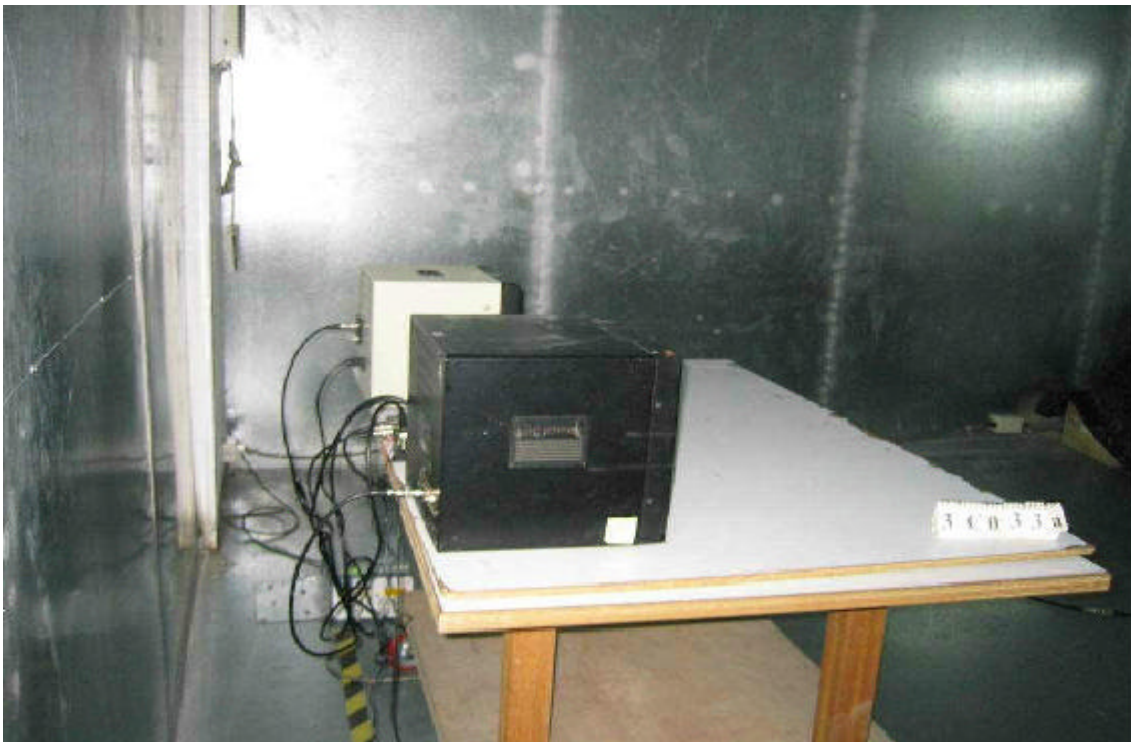

Rear View

### PHOTO OF CLAMP EMISSION TEST

Test Mode : VIDEO INPUT , Model : CD102



Front View



Rear View



HomeTek Technology Inc.

## **Appendix B**

### **PHOTOS OF EUT**

### PHOTO OF EUT

Model : CD102

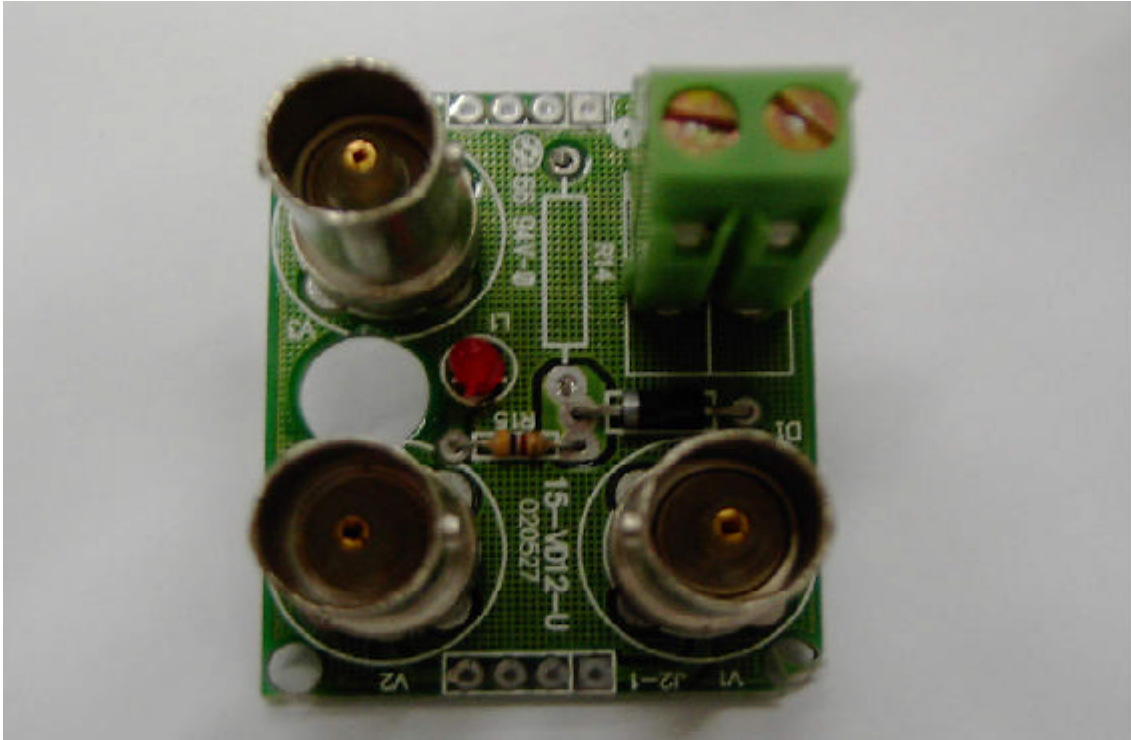

Component Side of Main Board

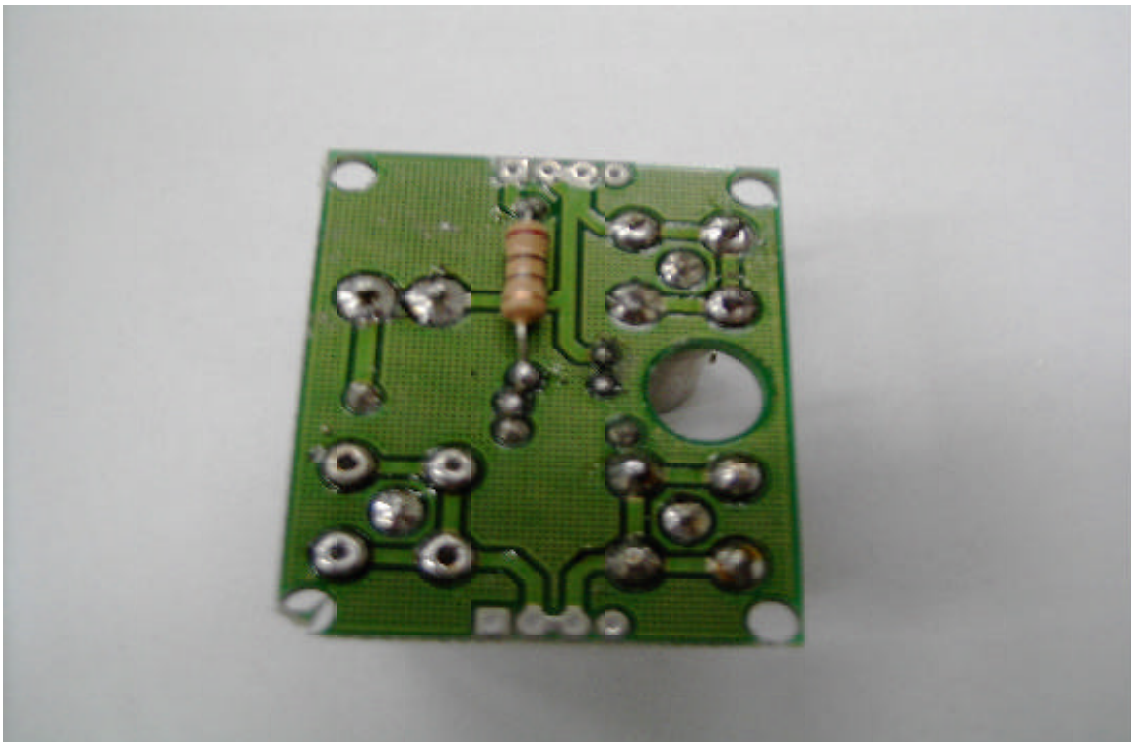

Solder Side of Main Board

# Declaration of Conformity

Responsible Party Name :

Address :

Phone No :

Fax No :

Declares under our sole responsibility that the product

Product Name : Video Distributor & Amplifier

Model No. : CD102XX

to which this declaration relates is in conformity with the following standards or other normative documents

AS/NZS CISPR 13: 2003 Sound and television broadcast receivers and associated equipment -  
Radio disturbance characteristics – Limits and methods of measurement

Representative Person's Name : \_\_\_\_\_

Signature : \_\_\_\_\_

Date : \_\_\_\_\_

United States Department of Commerce  
National Institute of Standards and Technology

**NVLAP**®



ISO/IEC 17025:1999  
ISO 9002:1994

Certificate of Accreditation

**HOMETEK TECHNOLOGY INC.**

TAIPEI SHIEN 236  
TAIWAN

*is recognized by the National Voluntary Laboratory Accreditation Program  
for satisfactory compliance with criteria set forth in NIST Handbook 150:2001,  
all requirements of ISO/IEC 17025:1999, and relevant requirements of ISO 9002:1994.  
Accreditation is awarded for specific services, listed on the Scope of Accreditation, for:*

**ELECTROMAGNETIC COMPATIBILITY AND TELECOMMUNICATIONS**

September 30, 2004

*Effective through*

A handwritten signature in black ink, appearing to read "Peter P. Welch".

For the National Institute of Standards and Technology  
NVLAP Lab Code: 200331-0

## Scope of Accreditation



### ELECTROMAGNETIC COMPATIBILITY AND TELECOMMUNICATIONS

NVLAP LAB CODE 200331-0

#### HOMETEK TECHNOLOGY INC.

P.O Box: 13-131, Pan-Chiao City  
No. 67-9 Shir Men Rd., Tu Chen City  
Taipei Shien 236  
TAIWAN

Mr. Grant Huang

Phone: 886-2-22608375 Fax: 886-2-22748013

E-Mail: hometek@ms15.hinet.net

#### *NVLAP Code Designation / Description*

#### **Emissions Test Methods:**

- |           |  |
|-----------|--|
| 12/CIS22  | IEC/CISPR 22 (1997) and EN 55022 (1998): Limits and methods of measurement of radio disturbance characteristics of information technology equipment                      |
| 12/CIS22a | IEC/CISPR 22 (1993): Limits and methods of measurement of radio disturbance characteristics of information technology equipment, Amendment 1:1995, and Amendment 2:1996. |
| 12/CIS22b | CNS 13438 (1997): Limits and Methods of Measurement of Radio Interference Characteristics of Information Technology Equipment  |
| 12/FCC15b | ANSI C63.4 (2001) with FCC Method - 47 CFR Part 15, Subpart B: Unintentional Radiators   |
| 12/T51    | AS/NZS CISPR 22 (2002) and AS/NZS 3548 (1997): Electromagnetic Interference - Limits and Methods of Measurement of Information Technology Equipment                      |

September 30, 2004

Effective through

For the National Institute of Standards and Technology