

HomeTek Technology Inc.

ADDRESS: No. 67-9, Shir Men Road, Tu Cheng City,
Taipei Hsien, Taiwan

PHONE : 886-2-22608375 FAX : 886-2-22748013

E - mail : hometek@ms15.hinet.net

CERTIFICATE OF COMPLIANCE

EUT : Hi Frequency Interference Blocker
MODEL NO. : CHB00XXXT, CHB00XXR
Receipt Date : 05/15/2007 Final Test Date: 05/29/2007
REPORT # : EB6E026
APPLICANT : SMART CABLING & TRANSMISSION CORP.
ADDRESS : 10F, No. 493, Chung-Cheng Rd.,
Hsin Tien City, Taipei 231, Taiwan, R. O. C.

Measurement procedure used:

EMI: EN 61000-6-3 (2001): CISPR 22 Class B (1997),

EN 61000-3-2 (2000), EN 61000-3-3 (1995) + A1 (2001)

EMS: EN 50130-4 (1995) + A1 (1998) + A2 (2003):

IEC 61000-4-2 (2001), IEC 61000-4-3 (2002), IEC 61000-4-4 (2004),

IEC 61000-4-5 (2001), ENV 50141 (1993), IEC 61000-4-11 (2004)

We hereby show that:

The measurements shown in this test report were made in accordance with the procedures given in **EUROPEAN COUNCIL DIRECTIVE 2004/108/EC**, and the energy emitted by the equipment was found to be within the limits applicable.

This test result of this report applies to above tested sample only.

This test report shall not be reproduce in part without written approval of HomeTek Technology Inc.

APPROVED BY :  5/31/2007

ALAIN LIN / Supervisor



TABLE OF CONTENTS..... 1

GENERAL INFORMATION..... 4

MODIFICATION LIST..... 5

CONDUCTED POWER LINE TEST 6

1 TEST INSTRUMENTS & FACILITIES..... 6

2 TEST PROCEDURE..... 6

3 TEST SETUP 7

4 CONFIGURATION OF THE EUT 9

5 EUT OPERATING CONDITION..... 13

6 LIMIT OF CONDUCTED POWER LINE EMISSION CLASS B..... 14

7 RESULT OF CONDUCTED POWER LINE TEST..... 14

8 CONDUCTED POWER LINE TEST DATA (PAGE 1)..... 15

9 CONDUCTED POWER LINE TEST DATA (PAGE 2)..... 16

10 CONDUCTED POWER LINE TEST DATA (PAGE 3)..... 17

11 CONDUCTED POWER LINE TEST DATA (PAGE 4)..... 18

RADIATED EMISSION TEST..... 19

1 TEST INSTRUMENTS & FACILITIES..... 19

2 TEST PROCEDURE..... 20

3 TEST SETUP 20

4 CONFIGURATION OF THE EUT 21

5 EUT OPERATING CONDITION..... 21

6 LIMIT OF RADIATED EMISSION CLASS B 21

7 RESULT OF RADIATED EMISSION TEST..... 21

8 RADIATED EMISSION TEST DATA (PAGE 1)..... 22

9 RADIATED EMISSION TEST DATA (PAGE 2)..... 23

HARMONICS TEST..... 24

1 TEST INSTRUMENTS & FACILITIES..... 24

2 TEST PROCEDURE..... 24

3 TEST SETUP 24

4 CONFIGURATION OF THE EUT 24

5 OPERATION CONDITION OF EUT..... 24

6 TEST DATA & LIMIT..... 24

7 PHOTOS OF TEST CONFIGURATION PLEASE REFER TO APPENDIX A..... 24

8 HARMONICS TEST DATA (PAGE 1~2)..... 25

VOLTAGE FLUCTUATIONS TEST 27

1 TEST INSTRUMENTS & FACILITIES..... 27

2 TEST PROCEDURE..... 27

3 TEST SETUP 27



4 CONFIGURATION OF THE EUT 27

5 OPERATION CONDITION OF EUT 27

6 TEST DATA & LIMIT 27

7 PHOTOS OF TEST CONFIGURATION PLEASE REFER TO APPENDIX A 27

8 VOLTAGE FLUCTUATIONS TEST DATA (PAGE 1) 28

ELECTROSTATIC DISCHARGE IMMUNITY TEST (ESD) 29

1 TEST INSTRUMENTS & FACILITIES 29

2 TEST PROCEDURE 29

3 TEST SETUP 29

4 CONFIGURATION OF THE EUT 30

5 EUT OPERATION CONDITION 30

6 TEST CONDITION 30

7 PERFORMANCE CRITERIA 30

8 TEST RESULT 31

RADIO FREQUENCY ELECTROMAGNETIC FIELD IMMUNITY TEST (RF)..... 32

1 TEST INSTRUMENTS & FACILITIES 32

2 TEST PROCEDURE 32

3 TEST SETUP 33

4 CONFIGURATION OF THE EUT 34

5 OPERATION CONDITION OF EUT 34

6 TEST CONDITION 34

7 PERFORMANCE CRITERIA 34

8 TEST RESULT 35

ELECTRICAL FAST TRANSIENT/BURST IMMUNITY TEST (EFT)..... 36

1 TEST INSTRUMENTS & FACILITIES 36

2 TEST PROCEDURE 36

3 TEST SETUP 36

4 CONFIGURATION OF THE EUT 37

5 OPERATION CONDITION OF EUT 37

6 TEST CONDITION 37

7 PERFORMANCE CRITERIA 37

8 TEST RESULT 38

SURGE IMMUNITY TEST 39

1 TEST INSTRUMENTS & FACILITIES 39

2 TEST PROCEDURE 39

3 TEST SETUP 39

4 TEST LEVELS 40

5 CONFIGURATION OF THE EUT 40

6 EUT OPERATION CONDITION 40



7 CONDITIONS DURING TESTING 41

8 PERFORMANCE CRITERIA 41

9 TEST RESULT 42

IMMUNITY TEST TO CS CONDUCTED DISTURBANCE 43

1 TEST INSTRUMENTS & FACILITIES 43

2 TEST PROCEDURE 43

3 TEST SETUP 44

4 TEST LEVELS 45

5 CONFIGURATION OF THE EUT 45

6 EUT OPERATION CONDITION 45

7 CONDITIONS DURING TESTING 45

8 PERFORMANCE CRITERIA 46

9 TEST RESULT 46

VOLTAGE DIPS, SHORT INTERRUPTIONS IMMUNITY TEST AND MAIN SUPPLY VARIATIONS 47

1 TEST INSTRUMENTS & FACILITIES 47

2 TEST PROCEDURE 47

3 TEST SETUP 47

4 TEST LEVELS FOR DIPS 48

5 CONFIGURATION OF THE EUT 48

6 EUT OPERATION CONDITION 48

7 CONDITIONS DURING TESTING 48

8 PERFORMANCE CRITERIA 49

9 TEST RESULT 49

10 TEST LEVELS FOR MAIN SUPPLY VARIATIONS 50

11 PERFORMANCE CRITERIA 50

12 TEST RESULT 50

APPENDIX A

PHOTOS OF TEST CONFIGURATION

APPENDIX B

PHOTOS OF EUT

GENERAL INFORMATION

- 1 APPLICANT : SMART CABLING & TRANSMISSION CORP.
- 2 ADDRESS : 10F, No. 493, Chung-Cheng Rd.,
Hsin Tien City, Taipei 231, Taiwan, R. O. C.
- 3 MANUFACTURER : SMART CABLING & TRANSMISSION CORP.
- 4 ADDRESS : 10F, No. 493, Chung-Cheng Rd.,
Hsin Tien City, Taipei 231, Taiwan, R. O. C.
- 5 DESCRIPTION OF EUT :
 EUT : Hi Frequency Interference Blocker
 Model : CHB00XXXT, CHB00XXXR
 Serial # : N/A

5.1 The difference between series of models CHB00XXXT and CHB00XXXR are as shown below:

Difference Mode No.	Transmitter	Receiver	Remark
CHB00XXXT	Yes	No	(1) The first and second “X” represents different system input.
CHB00XXXR	No	Yes	(2) The third “X” represent different accessory.

The PCB layout is similar. The worst case of EMC test data were shown in this test report.

6 FEATURES OF EUT :

Please refer to user manual or product specification.



HomeTek Technology Inc.

MODIFICATION LIST

THE FOLLOWING ACCESSORIES WERE ADDED TO THE EUT DURING TESTING :

NO MODIFICATION BY HOMETEK TECHNOLOGY INC.

CONDUCTED POWER LINE TEST

1 TEST INSTRUMENTS & FACILITIES

The following test Instruments was used during the conducted test :

Item	Instruments/ Facilities	Specification	Manufacturer	Model #	Date Of Cal.
1	EMI Receiver	9KHz ~ 30MHz	ROHDE & SCHWARZ	ESHS 30 844827/007	FEB/2007
2	LISN (for EUT)	50Ω/50uH/100A 150KHz ~ 30MHz	SCHWARZ BECK	NNLK 8121 8121370	OCT/2006
3	LISN (for Support Unit)	50Ω/50uH/10A 9KHz ~ 30MHz	ROHDE & SCHWARZ	ESH3-Z5 846128/007	MAR/2007
4	Terminator	50Ω	N/A	N/A	NOV/2006
5	Attenuation	50Ω/10dB	Mini-Circuit	NAT-10 AT-002	JUL/2006
6	Cable	5.4m	SUHNER	RG-223 CON2-002	AUG/2006
7	ESXS-K1 (software)	Version 2.03b 9KHz ~ 30MHz	ROHDE & SCHWARZ	1082.9678.02 840.913/246	N/A

Note : Items 1 ~ 6 were calibrated within period of 1 year.

2 TEST PROCEDURE

- 2.1 The EUT was tested according to **EN 61000-6-3**.
- 2.2 The EUT was placed 0.4 meter from the conducting wall of shielding room and kept at least 0.8 meter from any other grounded conducting surface.
- 2.3 The frequency range form 0.15 MHz to 30 MHz was investigated.
- 2.4 The LISN used was 50 Ohm / 50 uHenry as specified by **CISPR 22 Class B**.
- 2.5 All the support peripherals are connect to the other LISN.
- 2.6 Cables and peripherals were moved to find the maximum emission levels for each frequency.

3 TEST SETUP

3.1 Typical : Setup Of Conducted Test

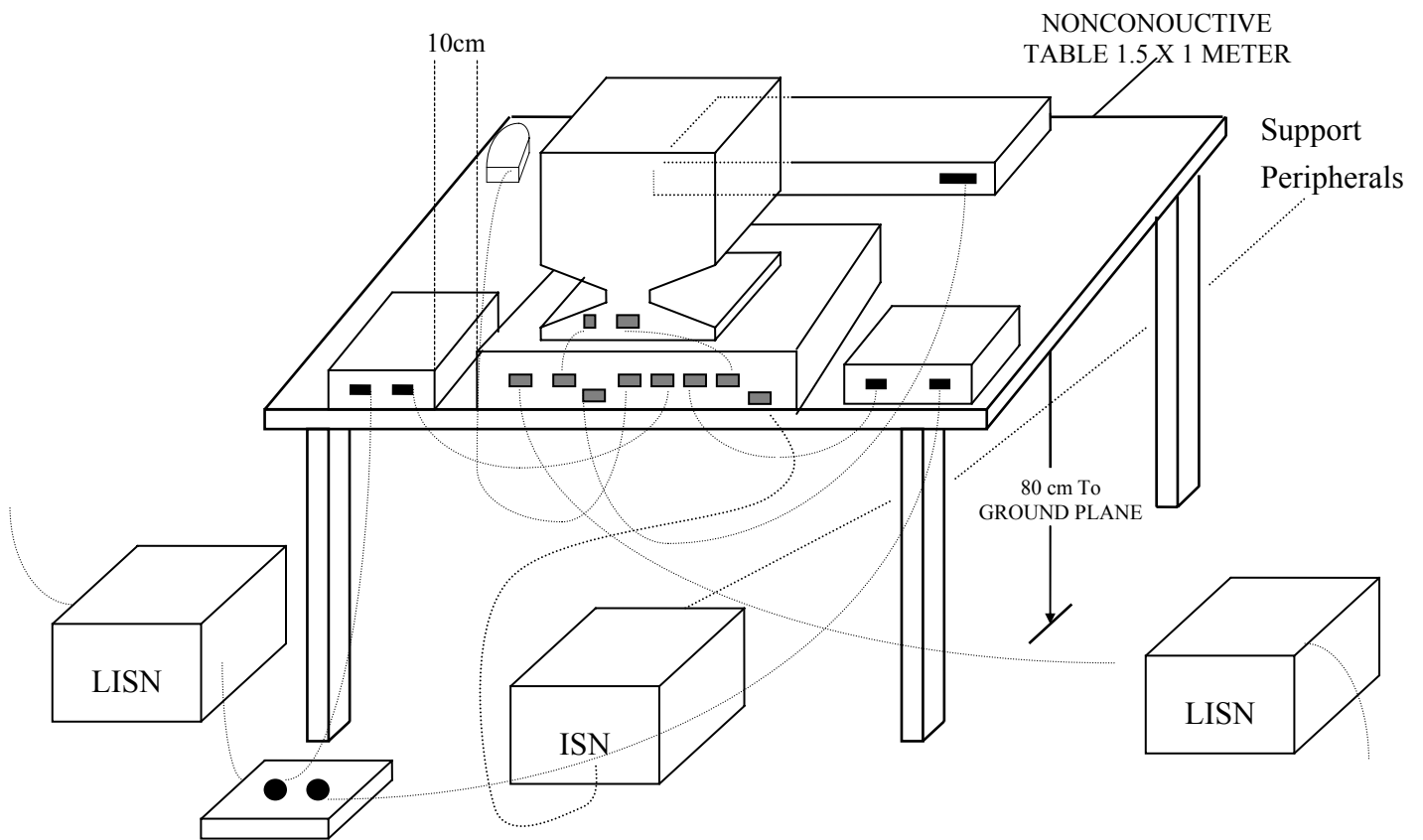

(Details for setup configuration, please refer to appendix A.)

3.2 Block Diagram Of Conducted Test

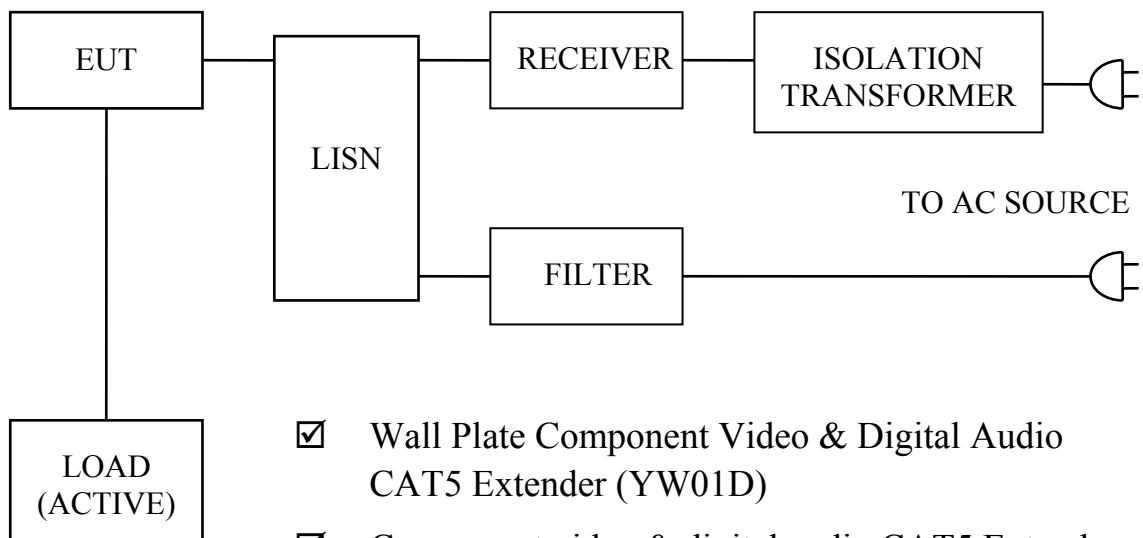

- Wall Plate Component Video & Digital Audio CAT5 Extender (YW01D)
- Component video & digital audio CAT5 Extender (CV01A)
- Digital Audio Transceiver x 2 (DA01)
- 1 In to 4 Out Video Distributor
- TV
- DVD Player
- Load

4 CONFIGURATION OF THE EUT

The EUT was configured according to **EN 61000-6-3**. All I/O ports were connected to the appropriate peripherals. All peripherals and cables are listed below (including internal device) :

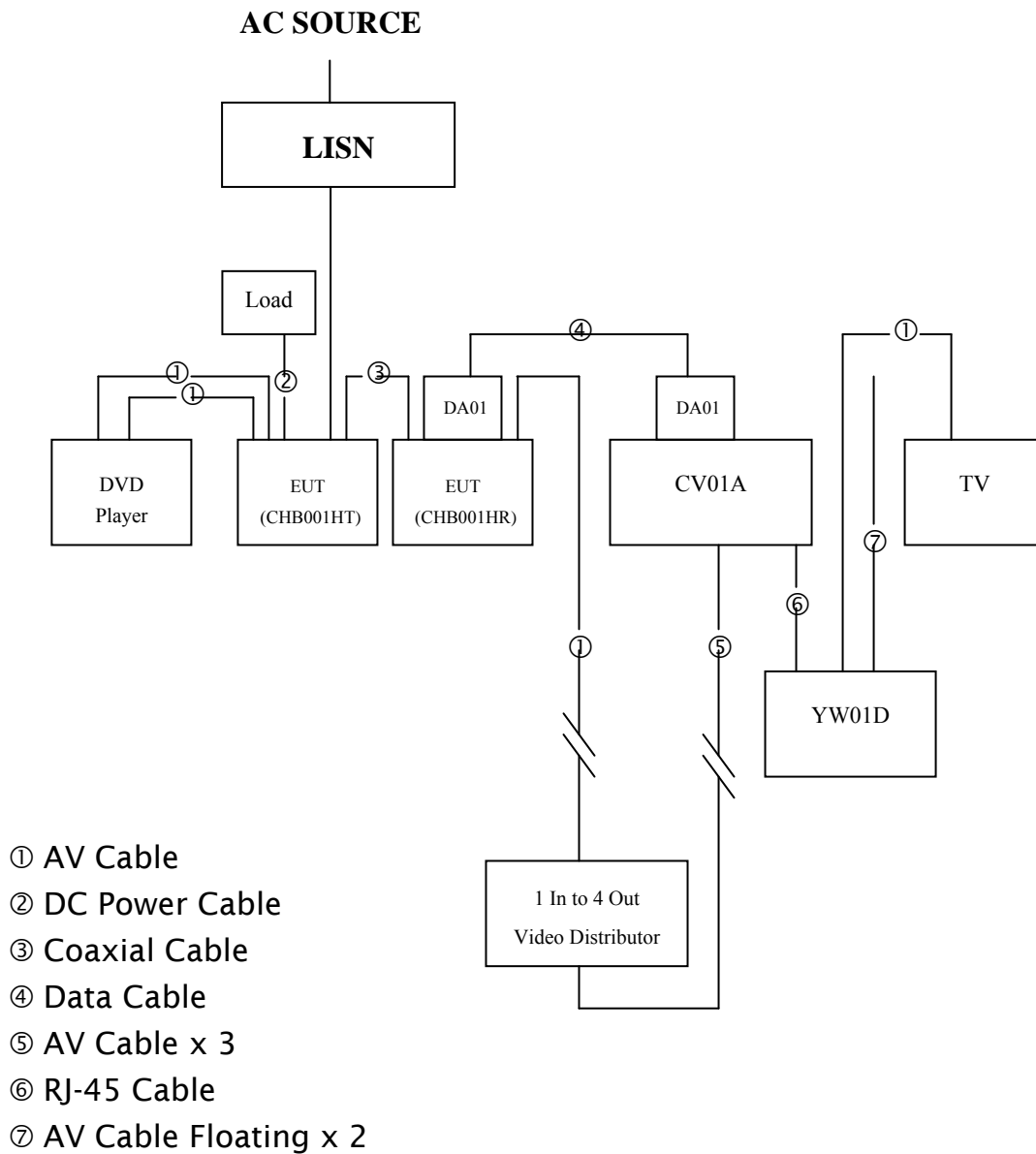

Figure 1

4.1 EUT

EUT Type : Proto Type Engineer Type Mass Production
Condition when received : Good Damage : _____
Device : Hi Frequency Interference Blocker
Applicant : SMART CABLING & TRANSMISSION CORP.
Manufacturer : SMART CABLING & TRANSMISSION CORP.
Model Number : CHB00XXXT, CHB00XXXR
Serial Number : N/A
FCC ID : N/A
AV In Port : Metal Type Connector
Audio In Port : Metal Type Connector
Video In Port : Metal Type Connector
AV Out Port : Metal Type Connector
Audio Out Port : Plastics Type Connector
Video Out Port : Metal Type Connector
DC 12V Out Port : Plastics Type Connector
Power Cord (AC) : 2 m
Power Cord (DC) : Un-Shielded, 1.8 m
Power Supply Type : Linear Adapter

4.2 PERIPHERALS

 Digital Audio Transceiver x 2

Manufacturer : SMART CABLING & TRANSMISSION CORP.
Model Number : DA01
Serial Number : N/A
FCC ID : N/A
Data Cable : Un-Shielded, 0.6 m
Power Cord & Adaptor : N/A



Wall Plate Component Video & Digital Audio CAT5 Extender

Manufacturer : SMART CABLING & TRANSMISSION CORP.
Model Number : YW01D
Serial Number : N/A
FCC ID : N/A
Data Cable 1 : Un-Shielded, 0.1 m, Connected to the RJ-45 port
Data Cable 2 : Un-Shielded, 1.6 m, Connected to the AV port
Power Cord : N/A

Component video & digital audio CAT5 Extender

Manufacturer : SMART CABLING & TRANSMISSION CORP.
Model Number : CV01A
Serial Number : N/A
FCC ID : N/A
Data Cable 1 : Un-Shielded, 0.1 m, Connected to the RJ-45 port
Data Cable 2 x 3 : Un-Shielded, 10 m, Connected to the AV port
Power Cord : N/A

1 In to 4 Out Video Distributor

Manufacturer : SMART CABLING & TRANSMISSION CORP.
Model Number : 15-VD14
Serial Number : N/A
FCC ID : N/A
Data Cable x 4 : Un-Shielded, 0.6 m, Connected to the AV port
Power Cord & Adaptor : Un-Shielded, 1.8 m



HomeTek Technology Inc.

DVD Player

Manufacturer : LG
Model Number : DS8421N
Serial Number : N/A
FCC ID : N/A
Data Cable : Shielded, 1.6 m, Connected to the AV port
Power Cord & Adaptor : Un-Shielded, 1.8 m

TV

Manufacturer : TCL
Model Number : 1419A
Serial Number : 010019502035F0039
FCC ID : N/A
Data Cable : Shielded, 1.6 m, Connected to the AV port
Power Cord : Un-Shielded

Power Adapter

Manufacturer : Atech
Model Number : ADP12500N-2
Serial Number : N/A
FCC ID : N/A
Data Cable : N/A
Power Cord (DC) : Un-Shielded, 1.8 m

Load

Manufacturer : HomeTek
Specification : 20 Ω
Serial Number : N/A
FCC ID : N/A
Data Cable : N/A
Power Cord : Un-Shielded, 0.3 m

4.3 REMARK : N/A

5 EUT OPERATING CONDITION

5.1 The crystal frequency of the EUT is 4 MHz.

5.2 Configure the EUT according to the **EN 61000-6-3**.

5.3

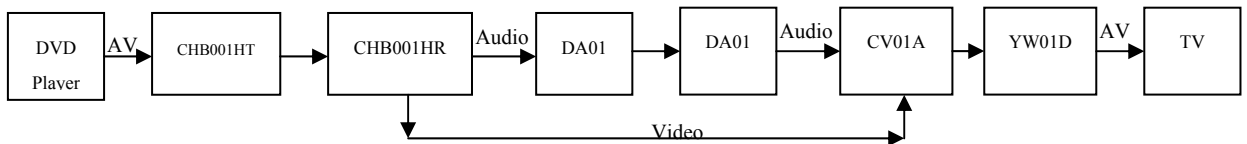

5.4 DVD Player send AV signal to CHB001HT, CHB001HR, DA01 x 2, CV01A, YW01D, and CHB001HT, CHB001HR, DA01 x 2, CV01A, YW01D change AV signal.

5.5 Then has changed AV signal send to TV display.

5.6 Measure the maximum emission noise.

5.7 The photos of conducted test configuration, please refer to appendix A.

6 LIMIT OF CONDUCTED POWER LINE EMISSION CLASS B

Frequency Range	Quasi Peak	Average
0.15 ~ 0.5 MHz	66 - 56 dBuV	56 - 46 dBuV
0.5 ~ 5 MHz	56 dBuV	46 dBuV
5 ~ 30 MHz	60 dBuV	50 dBuV

7 RESULT OF CONDUCTED POWER LINE TEST

7.1 The frequency range from 0.15 MHz to 30 MHz was investigated. All readings are quasi-peak values and average.

7.2 IF bandwidth : 9 kHz, Meas Time : 1 sec.

7.3 Temperature : 24 °C, Humidity : 60 % RH.

7.4 Deviations from the test standards and rules : None.

7.5 The conducted test result were gained by following procedures :
 Level = Reading Level + Insertion Loss of LISN + Cable Loss
 (All calculation were done by ESHS30 EMI test receiver.)

7.6 Result : **PASSED**

8 CONDUCTED POWER LINE TEST DATA (PAGE 1)

HomeTek EMC LAB. TEL :886-2-22608375

19 May 2007 16:06

CONDUCTED EMISSIONS

EUT: Hi Frequency Interference Blocker
 Manuf: 6E026
 Op Cond: LINE 1
 Operator: LIAO
 Test Spec: FOR EN55022 CLASS B
 Comment: 230V/50Hz
 CHB001HT
 Result File: 6e02611c.dat :

Prescan Measurement: Detectors: X PK / + AV
 Meas Time: see scan settings
 Subranges: 16
 Acc Margin: 55 dB

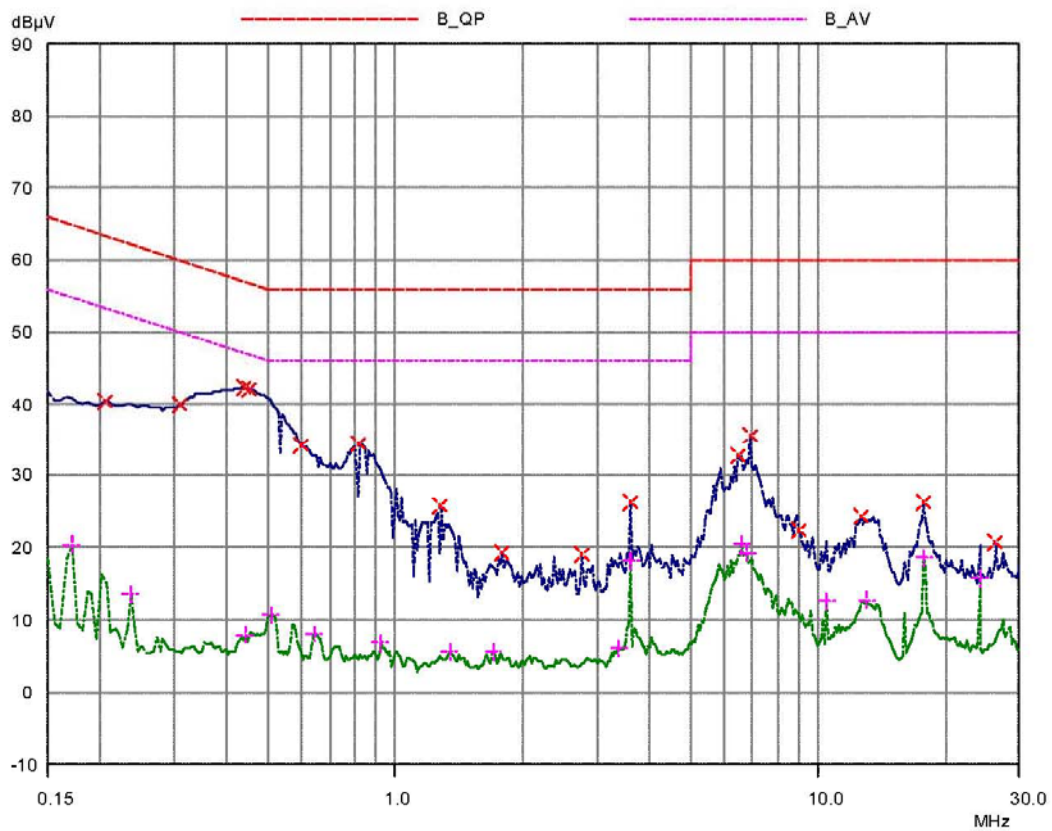



9 CONDUCTED POWER LINE TEST DATA (PAGE 2)

HomeTek EMC LAB. TEL :886-2-22608375

19 May 2007 16:06

CONDUCTED EMISSIONS

EUT: Hi Frequency Interference Blocker
 Manuf: 6E026
 Op Cond: LINE 1
 Operator: LIAO
 Test Spec: FOR EN55022 CLASS B
 Comment: 230V/50Hz
 CHB001HT
 Result File: 6e02611c.dat :

Prescan Measurement: Detectors: X PK / + AV
 Meas Time: see scan settings
 Subranges: 16
 Acc Margin: 55 dB

Peak Search Results

Frequency MHz	PK Level dBµV	PK Limit dBµV	PK Delta dB
0.205	40.43	63.41	22.98
0.31	39.84	59.97	20.13
0.44	42.31	57.06	14.75
0.45	42.14	56.88	14.74
0.6	34.13	56.00	21.87
0.82	34.39	56.00	21.61
1.28	25.72	56.00	30.28
1.78	19.32	56.00	36.68
2.74	19.14	56.00	36.86
3.57	26.23	56.00	29.77
6.46	32.79	60.00	27.21
6.87	35.68	60.00	24.32
9.01	22.35	60.00	37.65
12.67	24.40	60.00	35.60
17.78	26.23	60.00	33.77
26.13	20.61	60.00	39.39

Frequency MHz	AV Level dBµV	AV Limit dBµV	AV Delta dB
0.17	20.41	54.96	34.55
0.235	13.52	52.27	38.75
0.44	7.97	47.06	39.09
0.505	10.65	46.00	35.35
0.64	8.09	46.00	37.91
0.92	6.81	46.00	39.19
1.34	5.60	46.00	40.40
1.7	5.65	46.00	40.35
3.36	6.15	46.00	39.85
3.58	18.08	46.00	27.92
6.58	20.58	50.00	29.42
6.74	19.17	50.00	30.83
10.48	12.59	50.00	37.41
12.97	12.70	50.00	37.30
17.78	18.56	50.00	31.44
24.05	15.70	50.00	34.30

* limit exceeded

10 CONDUCTED POWER LINE TEST DATA (PAGE 3)

HomeTek EMC LAB. TEL :886-2-22608375

19 May 2007 16:13

CONDUCTED EMISSIONS

EUT: Hi Frequency Interference Blocker
 Manuf: 6E026
 Op Cond: LINE 2
 Operator: LIAO
 Test Spec: FOR EN55022 CLASS B
 Comment: 230V/50Hz
 CHB001HT
 Result File: 6e02621c.dat :

Prescan Measurement: Detectors: X PK / + AV
 Meas Time: see scan settings
 Subranges: 16
 Acc Margin: 55 dB

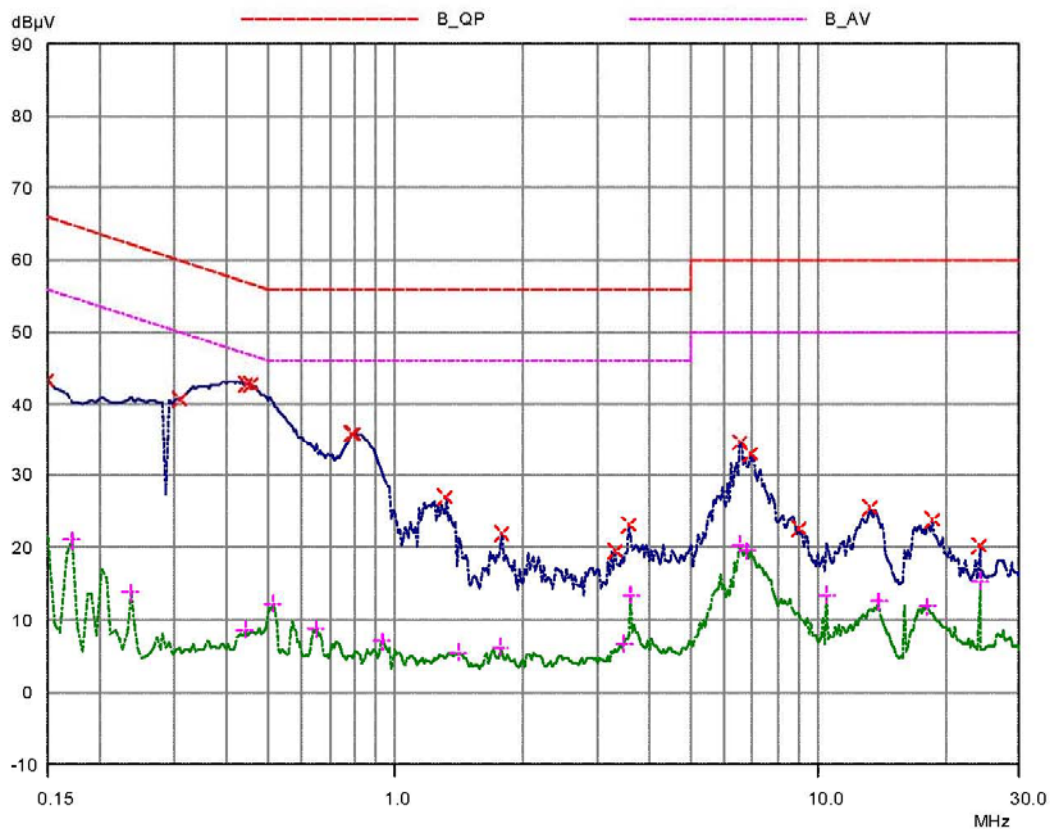



11 CONDUCTED POWER LINE TEST DATA (PAGE 4)

HomeTek EMC LAB. TEL :886-2-22608375

19 May 2007 16:00

CONDUCTED EMISSIONS

EUT: Hi Frequency Interference Blocker
 Manuf: 6E026
 Op Cond: LINE 2
 Operator: LIAO
 Test Spec: FOR EN55022 CLASS B
 Comment: 230V/50Hz
 CHB001HR
 Result File: 6e02622c.dat :

Prescan Measurement: Detectors: X PK / + AV
 Meas Time: see scan settings
 Subranges: 16
 Acc Margin: 55 dB

Peak Search Results

Frequency MHz	PK Level dBµV	PK Limit dBµV	PK Delta dB
0.215	39.77	63.01	23.24
0.31	39.60	59.97	20.37
0.435	42.13	57.16	15.03
0.455	41.88	56.78	14.90
0.79	34.78	56.00	21.22
0.8	35.42	56.00	20.58
1.27	25.68	56.00	30.32
1.8	21.52	56.00	34.48
3.36	19.32	56.00	36.68
3.58	31.19	56.00	24.81
6.69	35.24	60.00	24.76
6.8	37.03	60.00	22.97
9.01	23.79	60.00	36.21
14.25	25.16	60.00	34.84
21.31	19.98	60.00	40.02
27.38	24.62	60.00	35.38

Frequency MHz	AV Level dBµV	AV Limit dBµV	AV Delta dB
0.17	21.39	54.96	33.57
0.235	14.12	52.27	38.15
0.435	7.70	47.16	39.46
0.51	11.55	46.00	34.45
0.64	8.93	46.00	37.07
0.92	6.68	46.00	39.32
1.35	5.86	46.00	40.14
1.77	5.86	46.00	40.14
3.44	7.04	46.00	38.96
3.58	24.84	46.00	21.16
6.67	23.52	50.00	26.48
6.84	24.18	50.00	25.82
8.98	12.72	50.00	37.28
14.73	12.63	50.00	37.37
21.58	8.45	50.00	41.55
27.21	16.18	50.00	33.82

* limit exceeded

RADIATED EMISSION TEST

1 TEST INSTRUMENTS & FACILITIES

The following test Instruments was used during the radiated emission test :

Item	Instruments /facilities	Specification	Manufacturer	Model # / S/N#	Date of Cal.
1	OPEN AREA TEST SITE	<input checked="" type="checkbox"/> OATS 3			JUL/2006
2	EMI TEST RECEIVER	20Hz ~ 26.5GHz	ROHDE & SCHWARZ	ESMI 845442/006	FEB/2007
3	PRE-AMPLIFIER	9KHz ~ 3000MHz	ADVANTEST	BB525C 90081001	OCT/2006
4	ANTENNA (BI-LOG)	25MHz ~ 2GHz	SCHAFFNER	CBL6112B S/N : 2614	JUN/2006
5	Attenuation	50 Ω /6dB	JYE BAO	FAT-N (M-F) 001	JUL/2006
6	Cable	10m	SUHNER	RG214/U OS3-003	DEC/2006
7	Cable	14m	BELDEN	9913 OS3-001	DEC/2006
8	EMI 32 (software)	N/A	AUDIX	19991013-0923	N/A

Note : Items 1 ~ 7 were calibrated within period of 1 year.

2 TEST PROCEDURE

2.1 The EUT was test according to **CISPR 22 Class B**.

2.2 The radiated test was performed at HomeTek Lab's Open Site III.

2.3 The frequency range from 30 MHz to 1 GHz, the measurement were made at 10 meters, with a BI-log antenna.

3 TEST SETUP

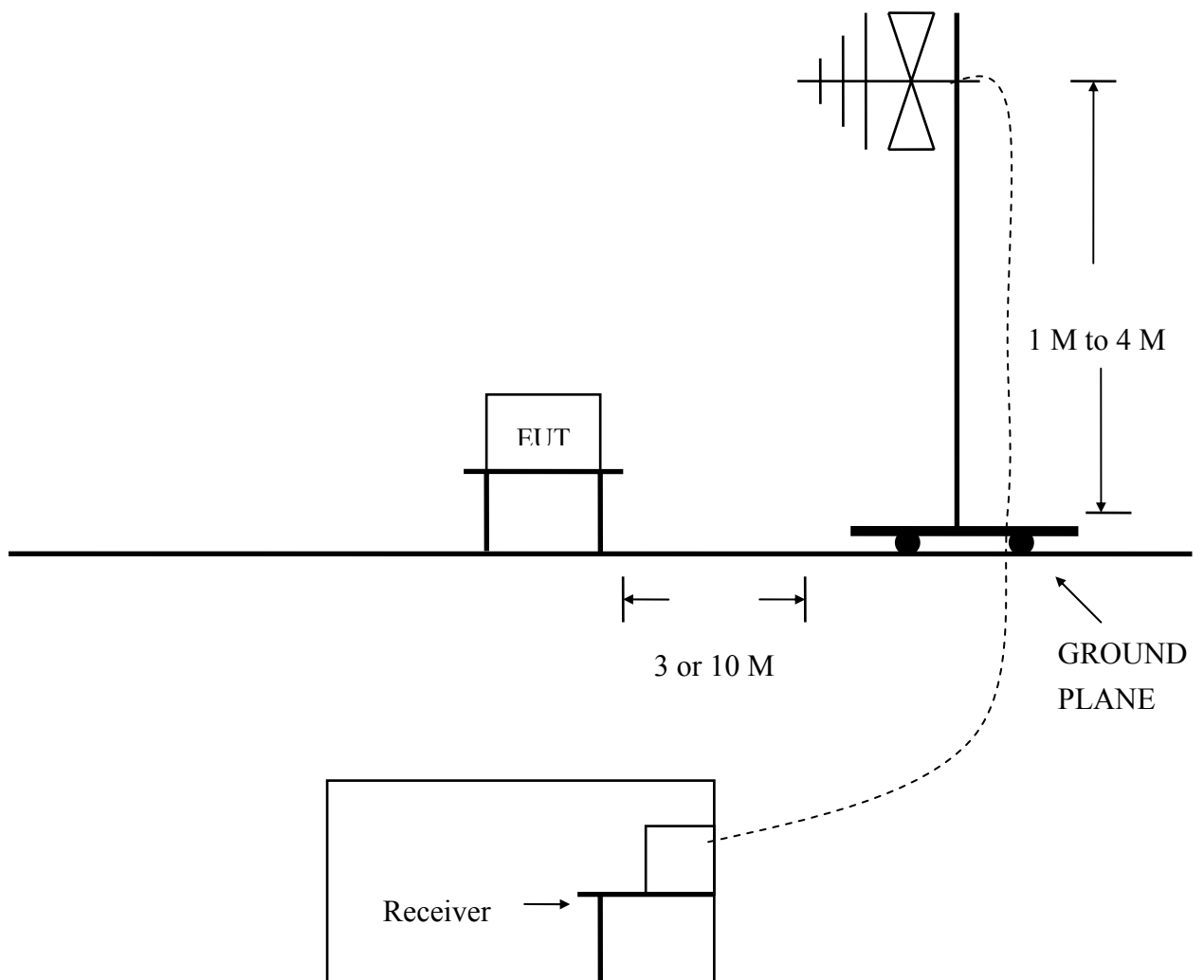

(Details for setup configuration, please refer to appendix A.)

4 CONFIGURATION OF THE EUT

Same as “Conducted Power Line test”, section 4

5 EUT OPERATING CONDITION

5.1 Same as “Conducted Power Line test”, section 5

5.2 The radiated emission in the frequency range from 30 MHz - 1000 MHz was test in a horizontal and vertical polarization at HomeTek Lab’s open site III.

5.3 The photos of radiated test configuration, please refer to appendix A.

6 LIMIT OF RADIATED EMISSION CLASS B

Frequency (MHz)	Measurement Distance	Limit (dBuV/m)
30 - 230	10 (M)	30
230 - 1000	10 (M)	37

7 RESULT OF RADIATED EMISSION TEST

7.1 The frequency range from 30 MHz to 1 GHz was investigated.

7.2 All readings below or equal 1 GHz are quasi-peak or peak values with resolution bandwidth of 120 KHz.

7.3 The measurements were made at 10 meters of HomeTek Lab’s open site III.

7.4 Temperature : 26 °C, Humidity : 56 % RH.

7.5 Deviation form the test standards and rules : None.

7.6 The radiated emission result were gained by the following method :

Level = Reading Level + Probe Factor (Antenna Factor) + Cable Loss – Preamp Factor

Over Limit = Level – Limit Line

7.7 Result : **PASSED**

8 RADIATED EMISSION TEST DATA (PAGE 1)



HomeTek Technology Inc.

No 67-9, Shi-Men Rd., Tu-Chen City,
 Taipei County, Taiwan R.O.C.
 Tel: 02-22608375
 Fax: 02-22748013

Data#: 4 File#: 6e026.EMI

Date: 2007-05-26 Time: 14:48:24

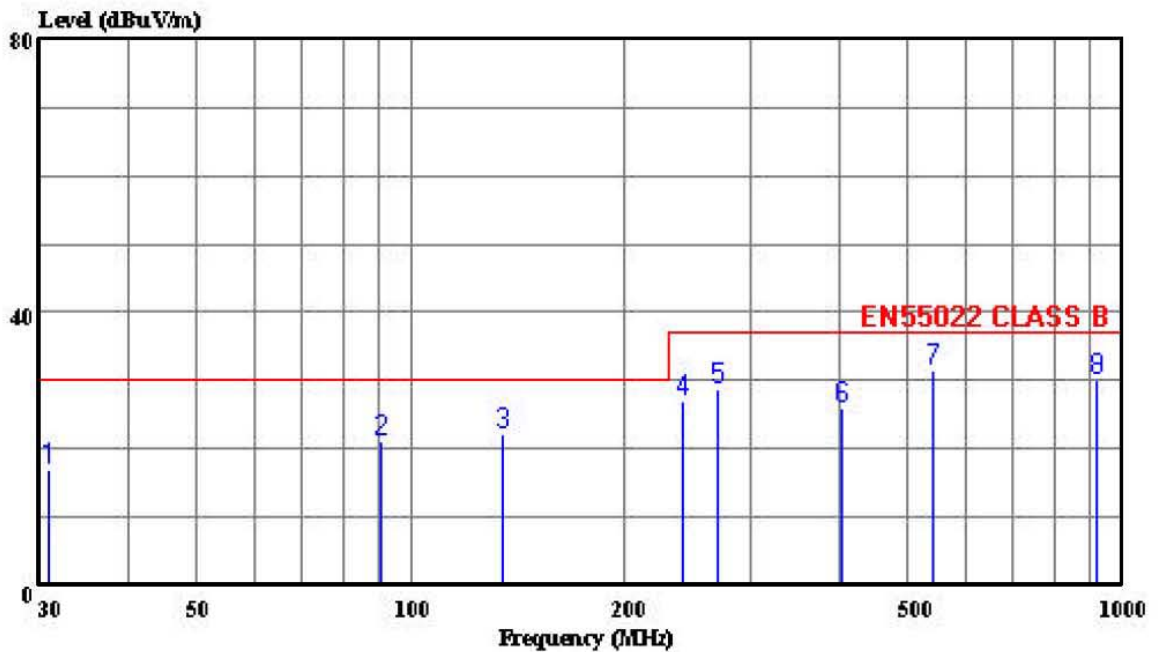

Trace:

Ref Trace:

Condition: EN55022 CLASS B 10m CHASE 2614 060506 HORIZONTAL
 eut : Hi Frequency Interference Blocker
 power: 230V/50Hz
 memo : CHB001HT, CHB001HR systems

Page: 1

	Limit	Over	ReadAntenna	Cable	Preamp				
Freq	Line	Limit	Level	Loss	Factor	Remark			
MHz	dBuV/m	dBuV/m	dB	dB	dB				
1	30.850	17.09	30.00	-12.91	24.25	18.22	0.64	26.02	Peak
2	90.750	20.97	30.00	-9.03	36.47	9.06	1.36	25.91	Peak
3	133.898	22.33	30.00	-7.67	34.97	11.46	1.73	25.83	Peak
4	241.501	27.11	37.00	-9.89	38.71	11.61	2.42	25.62	Peak
5	270.638	28.70	37.00	-8.30	39.05	12.62	2.60	25.56	Peak
6	404.483	26.07	37.00	-10.93	32.22	15.68	3.37	25.20	Peak
7	541.443	31.39	37.00	-5.61	32.79	18.49	4.78	24.68	Peak
8	920.290	30.21	37.00	-6.79	27.96	20.51	5.13	23.39	Peak
9	920.290	30.21	37.00	-6.79	27.96	20.51	5.13	23.39	Peak



9 RADIATED EMISSION TEST DATA (PAGE 2)



HomeTek Technology Inc.

No 67-9, Shi-Men Rd., Tu-Chen City,
Taipei County, Taiwan R.O.C.
Tel: 02-22608375
Fax: 02-22748013

Data#: 3 File#: 6e026.EMI

Date: 2007-05-26 Time: 13:56:38

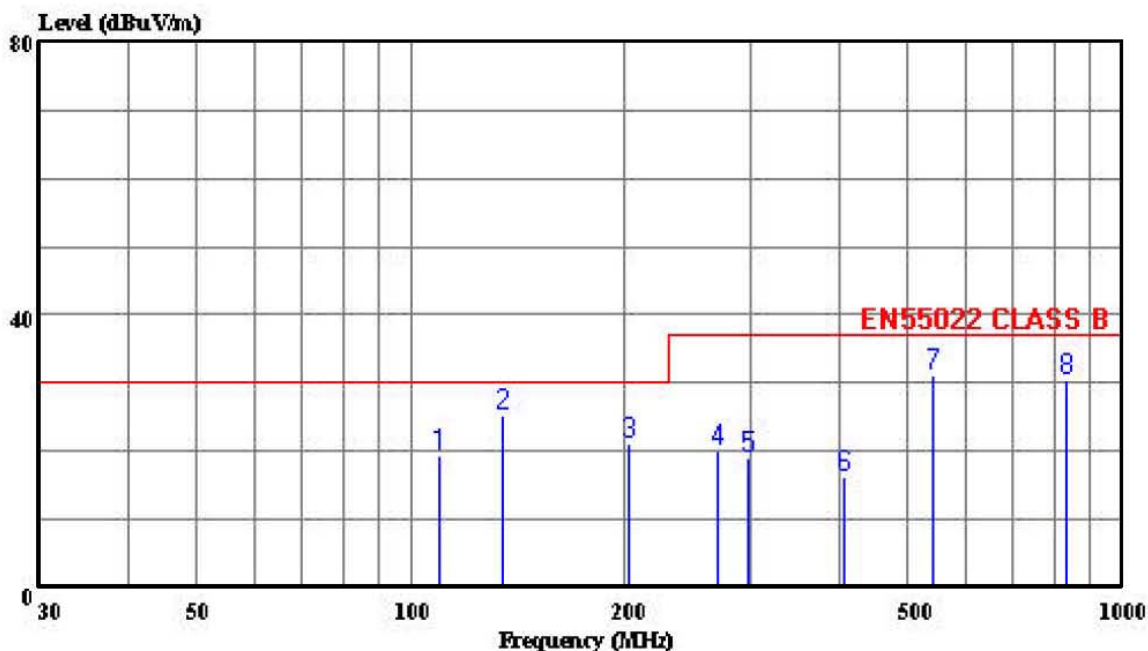

Trace:

Ref Trace:

Condition: EN55022 CLASS B 10m CHASE 2614 060506 VERTICAL
cut : Hi Frequency Interference Blocker
power: 230V/50Hz
memo : CHB001HT, CHB001HR systems

Page: 1

	Limit	Over	ReadAntenna	Cable	Preamp			
Freq	Level	Line	Level	Factor	Loss	Factor	Remark	
MHz	dBuV/m	dBuV/m	dB	dBuV	dB/m	dB	dB	
1	109.385	19.46	30.00	-10.54	31.77	12.03	1.54	25.88 Peak
2	133.963	25.21	30.00	-4.79	37.85	11.46	1.73	25.83 Peak
3	202.100	21.06	30.00	-8.94	35.53	9.10	2.13	25.71 Peak
4	269.988	20.06	37.00	-16.94	30.41	12.62	2.60	25.56 Peak
5	297.055	19.06	37.00	-17.94	28.75	13.06	2.75	25.50 Peak
6	405.138	16.11	37.00	-20.89	22.26	15.68	3.37	25.20 Peak
7	541.090	31.07	37.00	-5.93	32.47	18.49	4.78	24.68 Peak
8	834.787	30.32	37.00	-6.68	28.69	20.13	5.15	23.65 Peak

HARMONICS TEST

1 TEST INSTRUMENTS & FACILITIES

Instruments/ facilities	Manufacturer	Model # Serial #	Date of Cal.
HARMONICS/ VOLTAGE FLUCTUATIONS TEST	EMC-PARTNER	HAR1000-1P	NOV/2006
CONTROL PC	KB TECH	KB P586/133	N/A

Note : Item 1 were calibrated with two years and verified before testing.

2 TEST PROCEDURE

According to **EN 61000-3-2 (2000) Class A**

3 TEST SETUP

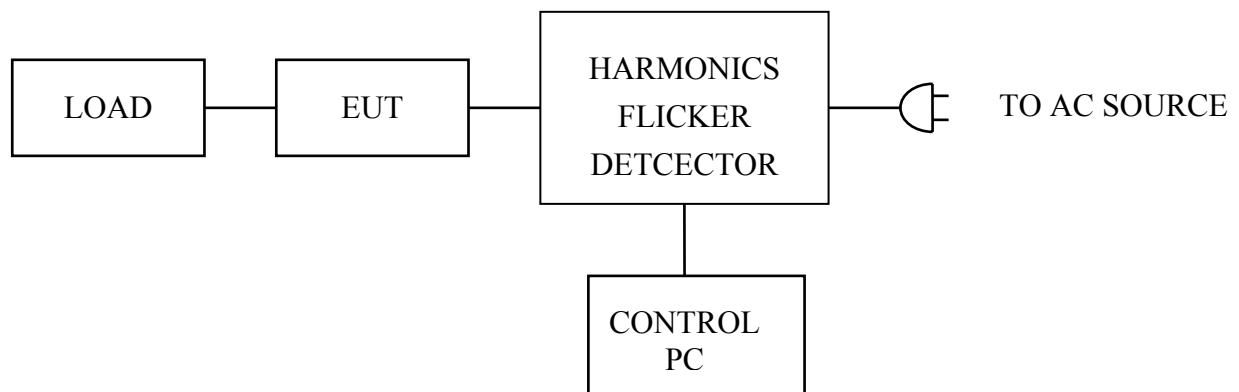

(Details for setup configuration, please refer to appendix A.)

4 CONFIGURATION OF THE EUT

Same as “Conducted Power Line test”, section 4

5 OPERATION CONDITION OF EUT

Same as “Conducted Power Line test”, section 5

6 TEST DATA & LIMIT

6.1 Temperature : 23 °C

6.2 Humidity : 55 % RH

7 Photos of test configuration please refer to appendix A.



8 HARMONICS TEST DATA (PAGE 1~2)

EMC PARTNER AG, SWITZERLAND

Date : 2007/5/24 PM 05:01:5 V4.14

Operator : Mello
 Unit : Hi Frequency Interference Blocker
 Serialnumber : CHB001HT
 Remarks : 6E026

Urms = 229.9V Freq = 49.987 Range: 0.25 A
 Irms = 0.029A Ipk = 0.046A cf = 1.587
 P = 4.160W S = 6.595VA pf = 0.631
 THDi = 37.6 % THDu = 0.10 % Class A

Test - Time : 15min (100 %)

Test completed, Result: PASSED

Order	Freq. [Hz]	I _{max} [A]	I _{max} %L [%]	Limit [A]	Status
1	50	0.0657			
2	100	0.0002	0.0155	1.0800	
3	150	0.0085	0.3675	2.3000	
4	200	0.0001	0.0142	0.4300	
5	250	0.0065	0.5702	1.1400	
6	300	0.0000	0.0051	0.3000	
7	350	0.0013	0.1724	0.7700	
8	400	0.0000	0.0066	0.2300	
9	450	0.0004	0.1068	0.4000	
10	500	0.0000	0.0000	0.1840	
11	550	0.0010	0.2913	0.3300	
12	600	0.0000	0.0000	0.1533	
13	650	0.0003	0.1453	0.2100	
14	700	0.0000	0.0000	0.1314	
15	750	0.0002	0.1628	0.1500	
16	800	0.0000	0.0000	0.1150	
17	850	0.0003	0.2421	0.1324	
18	900	0.0000	0.0000	0.1022	
19	950	0.0001	0.0902	0.1184	
20	10000	0.0000	0.0000	0.0920	
21	10500	0.0002	0.1424	0.1071	
22	11000	0.0000	0.0000	0.0836	
23	11500	0.0001	0.1248	0.0978	
24	12000	0.0000	0.0000	0.0767	
25	12500	0.0001	0.0848	0.0900	



HomeTek Technology Inc.

26	13000.0000	0.0000	0.0708
27	13500.0001	0.1099	0.0833
28	14000.0000	0.0000	0.0657
29	14500.0000	0.0590	0.0776
30	15000.0000	0.0000	0.0613
31	15500.0001	0.0841	0.0726
32	16000.0000	0.0000	0.0575
33	16500.0000	0.0671	0.0682
34	17000.0000	0.0000	0.0541
35	17500.0000	0.0475	0.0643
36	18000.0000	0.0000	0.0511
37	18500.0000	0.0753	0.0608
38	19000.0000	0.0000	0.0484
39	19500.0000	0.0529	0.0577
40	20000.0000	0.0000	0.0460

Important:

- without "1000-4-7 Ed. 2" (DFT-window is 16 periods)

VOLTAGE FLUCTUATIONS TEST

1 TEST INSTRUMENTS & FACILITIES

Instruments/ facilities	Manufacturer	Model # Serial #	Date of Cal.
HARMONICS/ VOLTAGE FLUCTUATIONS TEST	EMC-PARTNER	HAR1000-1P	NOV/2006
CONTROL PC	KB TECH	KB P586/133	N/A

Note : Item 1 were calibrated with two years and verified before testing.

2 TEST PROCEDURE

According to **EN 61000-3-3 (1995) + A1 (2001)**

3 TEST SETUP

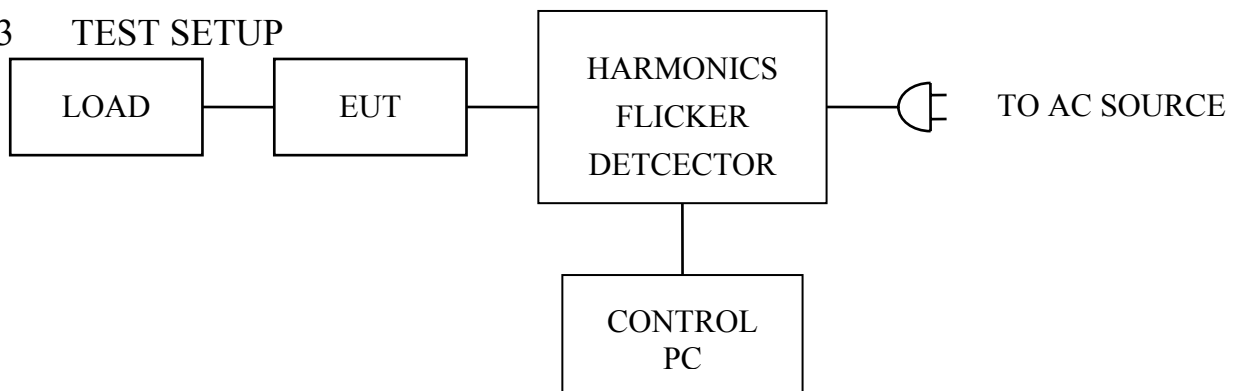

(Details for setup configuration, please refer to appendix A.)

4 CONFIGURATION OF THE EUT

Same as “Conducted Power Line test”, section 4

5 OPERATION CONDITION OF EUT

Same as “Conducted Power Line test”, section 5

6 TEST DATA & LIMIT

6.1 Temperature : 23 °C

6.2 Humidity : 55 % RH

7 Photos of test configuration please refer to appendix A.



8 VOLTAGE FLUCTUATIONS TEST DATA (PAGE 1)

EMC PARTNER AG, SWITZERLAND

Date : 2007/5/24 PM 05:17:0 V4.14

Operator : Mello
 Unit : Hi Frequency Interference Blocker
 Serialnumber : CHB001HT
 Remarks : 6E026

Urms = 229.9V Freq = 50.000 Range: 0.25 A
 Irms = 0.029A Ipk = 0.046A cf = 1.600
 P = 4.160W S = 6.595VA pf = 0.631

Test - Time : 1 x 15min = 15min (100 %)

LIN (Line Impedance Network) : L: 0.24ohm +j0.15ohm N: 0.16ohm +j0.10ohm

Limits :Plt : 0.65Pst : 1.00
 dmax : 4.00 % dc : 3.30 %
 dtLim: 3.30 % dt>Lim: 500ms

Test completed, Result: PASSED

Plt = 0.072

	Pst	dmax
		[%]
1	0.072	0.000

ELECTROSTATIC DISCHARGE IMMUNITY TEST (ESD)

1 TEST INSTRUMENTS & FACILITIES

Instruments/ Facilities	Manufacturer	Model # Serial #	Data Of Cal.
ESD TESTER	HAEFELY	PESD 1610	NOV/2006
VCP	HOMETEK	--	--

2 TEST PROCEDURE

According to **IEC 61000-4-2 (2001)**

According to **EN 50130-4 (1995) + A1 (1998) +A2 (2003)**

3 TEST SETUP

TABLE SIZE

160L X 80W X 80H cm

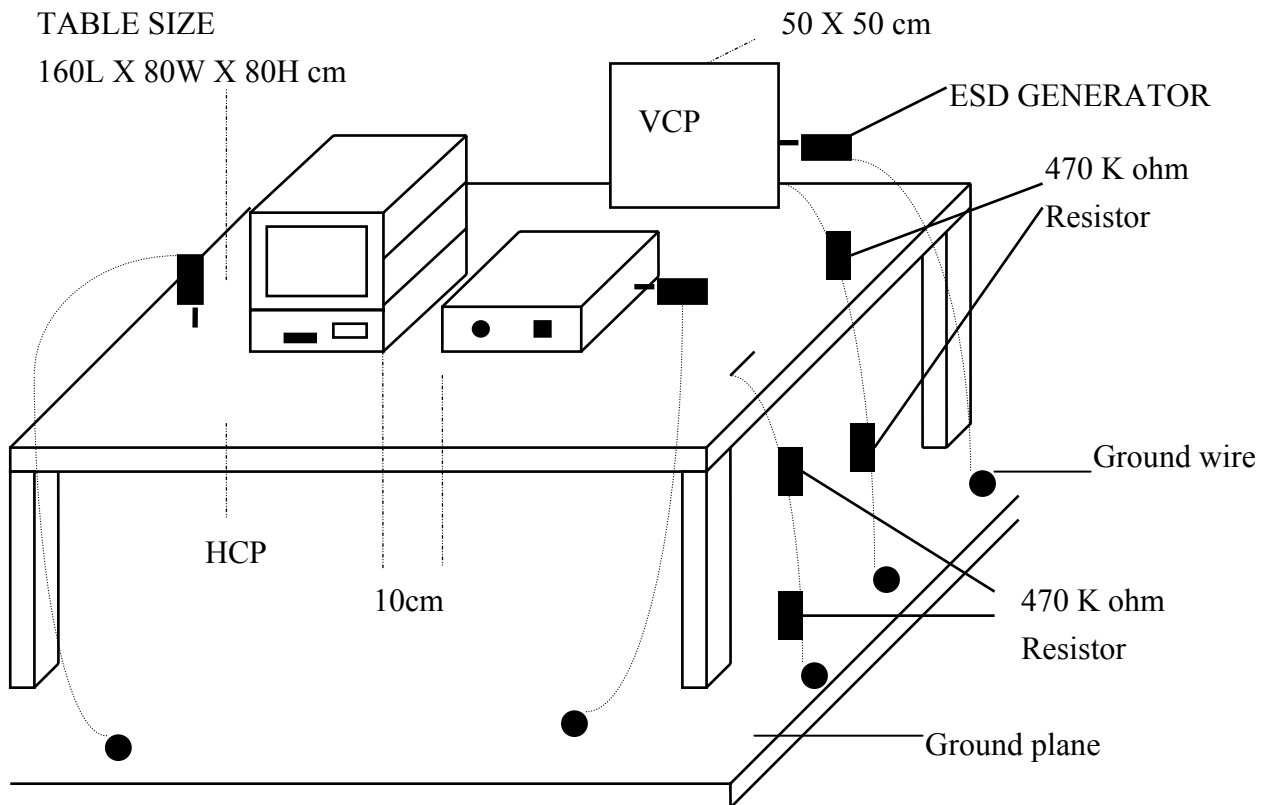

(Details for setup configuration, please refer to appendix A.)

4 CONFIGURATION OF THE EUT

Same as “Conducted Power Line test”, section 4

5 EUT OPERATION CONDITION

Same as “Conducted Power Line test”, section 5

6 TEST CONDITION

6.1 Test Level :

(A) $\pm 2, 4, 8$ KV for air discharge.

(B) $\pm 2, 4, 6$ KV for contact discharge.

6.2 Number of test : 10 Discharges / Test point / Polarity / Level

6.3 Time between test : ≥ 1 sec.

6.4 Temperature : 23 °C

6.5 Humidity : 41 % RH.

7 PERFORMANCE CRITERIA

There shall be no damage, malfunction or change of status due to the conditioning. Flickering of an indicator during the application of the discharges is permissible, providing that there is no residual change in the EUT or any change in outputs, which could be interpreted by associated equipment as a change.

The EUT shall meet the acceptance criteria for the functional test, after the conditioning.

8 TEST RESULT

Test Point	Air Discharge	Contact Discharge	Result
HCP	---	$\pm 2, 4, 6KV$	PASSED
VCP	---	$\pm 2, 4, 6KV$	PASSED
CASE	$\pm 2, 4, 8KV$	$\pm 2, 4, 6KV$	PASSED
I/O PORTS	$\pm 2, 4, 8KV$	$\pm 2, 4, 6KV$	PASSED
LED	$\pm 2, 4, 8KV$	$\pm 2, 4, 6KV$	PASSED
SCREWS	$\pm 2, 4, 8KV$	$\pm 2, 4, 6KV$	PASSED
DC SOCKET	$\pm 2, 4, 8KV$	$\pm 2, 4, 6KV$	PASSED

※ There is no significant change during the test.

9 Photos of test configuration please refer to appendix A.

RADIO FREQUENCY ELECTROMAGNETIC FIELD IMMUNITY TEST (RS)

1 TEST INSTRUMENTS & FACILITIES

Item	Instruments Facilities	Manufacturer	Model # Serial #	Data Of Cal.
1	SIGNAL GENERATOR	ROHDE & SCHWARZ	SMY02 845181/025	MAR/2007
2	AMPLIFIER	AMPLIFIER RESEARCH	100W1000M1A	N/A
3	FIELD SENSOR	AMPLIFIER RESEARCH	FP2000	AUG/2006
4	FIELD MONITOR	AMPLIFIER RESEARCH	FM2000	AUG/2006
5	RF VOLTMETER	BOONTON	9200C 361701AA	MAR/2007
6	RF PROBE	BOONTON	952001B 37082	MAR/2007
7	DIRECTION COUPLER	AMPLIFIER RESEARCH	DC6180 20521	N/A
8	ANTENNA	EMCO	3142B S/N: 1789	N/A
9	CONTROL PC	KB TECH	KB P586/133	--

Note : Items 3 ~ 4 were calibrated with two years and verified before testing.

2 TEST PROCEDURE

According to **IEC 61000-4-3 (2002)**

According to **EN 50130-4 (1995) + A1 (1998) + A3 (2003)**

3 TEST SETUP

FERRITE TILE

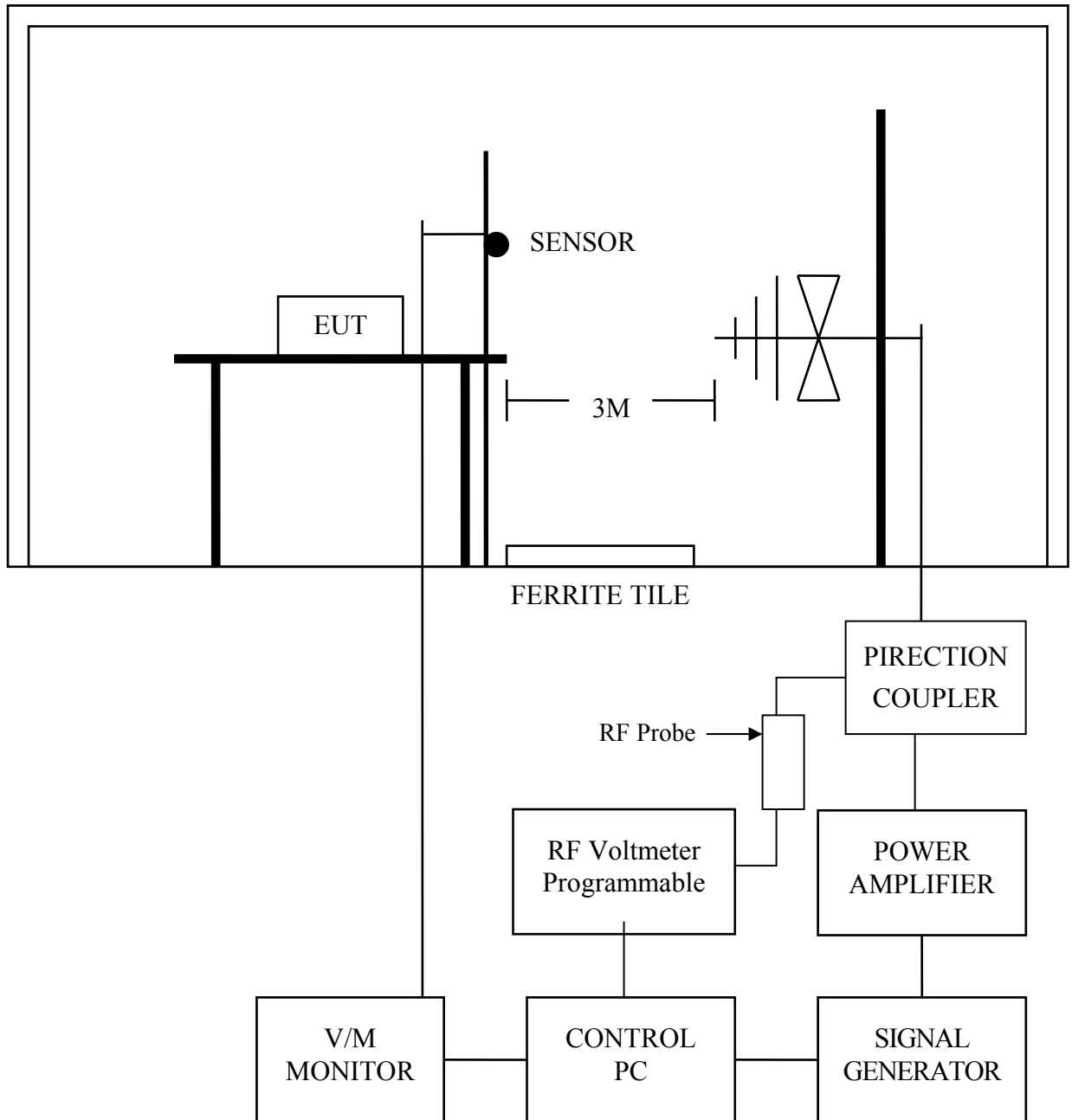

3.1 Chamber Size :

12M x 5M x 5M

(Details for setup configuration, please refer to appendix A.)

4 CONFIGURATION OF THE EUT

Same as “Conducted Power Line test”, section 4

5 OPERATION CONDITION OF EUT

Same as “Conducted Power Line test”, section 5

6 TEST CONDITION

6.1 Frequency Range : 80 MHz ~ 1000 MHz

6.2 Field Strength : 10 V / M (1KHz 80% Sinusoidal amplitude modulation)
10 V / M (1KHz 0.5s on : 0.5s off pulse modulation)

6.3 Frequency Step : 1 %, 3 sec. / each step size

6.4 Antenna Polarity : HORIZONTAL & VERTICAL

6.5 The four sides of EUT are tested
(FRONT, REAR, RIGHT, LEFT)

6.6 Temperature : 24 °C

6.7 Humidity : 58 % RH

7 PERFORMANCE CRITERIA

There shall be no damage, malfunction or change of status due to the conditioning. Flickering of an indicator during the conditioning is permissible, providing that there is no residual change in the EUT or any change in outputs, which could be interpreted by associated equipment as a change, and no such flickering of indicators occurs at a field strength of 3 V/m.

For components of CCTV system, where the status is monitored by observing the TV picture, then deterioration of the picture is allowed at 10 V/m, providing :

- a There is no permanent damage or change to the EUT (e.g. no corruption of memory or changes to programmable setting etc.);
- b At 3 V/m, any deterioration of the picture is so minor that the system could still be used;
- c There is no observable deterioration of the picture at 1 V/m.

The EUT shall meet the acceptance criteria for the functional test, after the conditioning.

8 TEST RESULT

ANT SIDE	HORIZONTAL	VERTICAL
FRONT	PASSED	PASSED
REAR	PASSED	PASSED
RIGHT	PASSED	PASSED
LEFT	PASSED	PASSED

9 Photos of test configuration please refer to appendix A.

ELECTRICAL FAST TRANSIENT/BURST IMMUNITY TEST (EFT)

1 TEST INSTRUMENTS & FACILITIES

Instruments/ Facilities	Manufacturer	Model # Serial #	Data Of Cal.
BURST-TESTER	HAEFELY	PEFT/JUNIOR	FEB/2007
CONTROL PC	KB TECH	KB P586/133	--

2 TEST PROCEDURE

According to **IEC 61000-4-4 (2004)**

According to **EN 50130-4 (1995) + A1 (1998) + A2 (2003)**

3 TEST SETUP

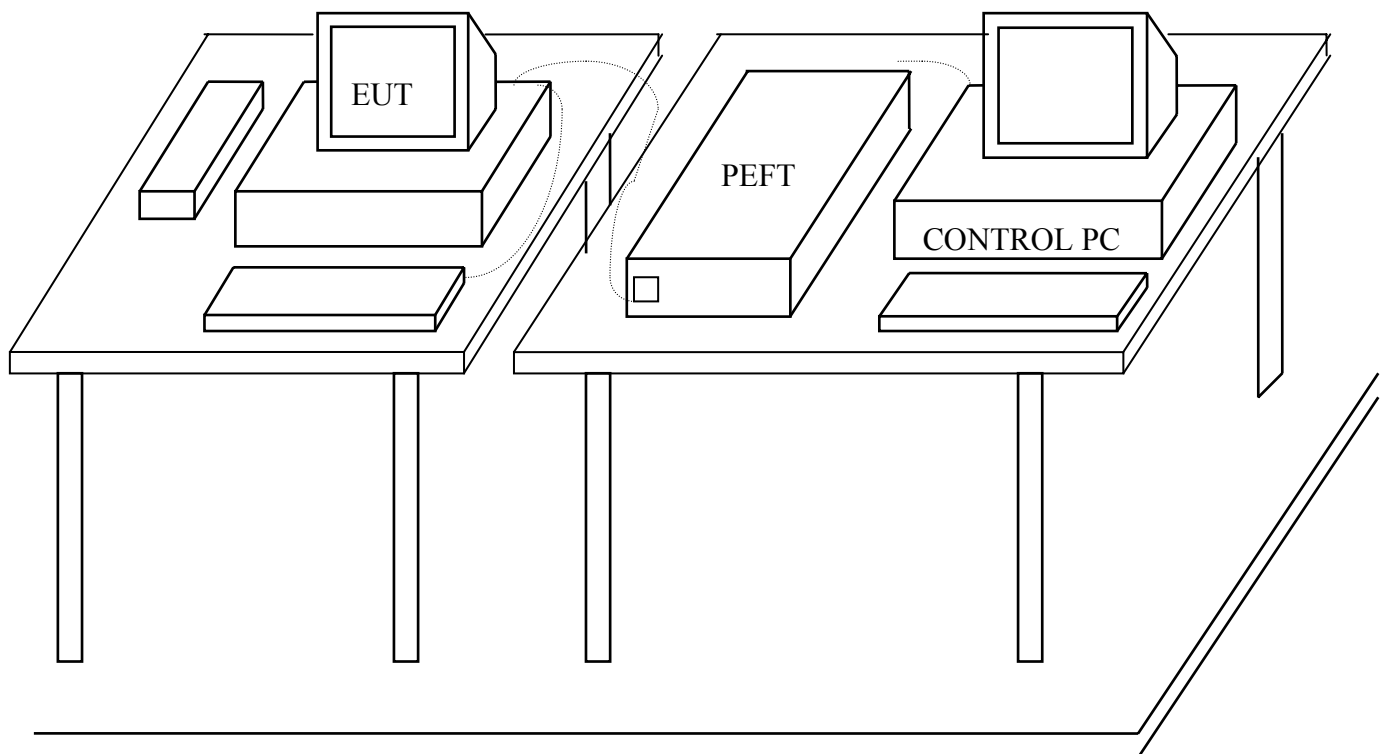

GROUND PLANE
(Details for setup configuration, please refer to appendix A.)

4 CONFIGURATION OF THE EUT

Same as “Conducted Power Line test”, section 4

5 OPERATION CONDITION OF EUT

Same as “Conducted Power Line test”, section 5

6 TEST CONDITION

6.1 Pulse Rise time & Duration : 5 nS / 50 nS

6.2 Pulse Repetition : 5 kHz

6.3 Polarity : POSITIVE / NEGATIVE

6.4 Test Voltage of Power Line : $\pm 0.5\text{KV}$, $\pm 1\text{KV}$, $\pm 2\text{KV}$

6.5 Coupling of power line :
L, N, L+N

6.6 Test Voltage of Signal Control Line : $\pm 0.25\text{KV}$, $\pm 0.5\text{KV}$, $\pm 1\text{KV}$

6.7 Temperature : 23 °C

6.8 Humidity : 55 % RH

7 PERFORMANCE CRITERIA

There shall be no damage, malfunction or change of status due to the conditioning. Flickering of an indicator during the application of the bursts is permissible, providing that there is no residual change in the EUT or any change in outputs, which could be interpreted by associated equipment as a change.

The EUT shall meet the acceptance criteria for the functional test, after the conditioning.

8 TEST RESULT

Power Line :

TEST VOLTAGE	L	N	PE	L+N	L+PE	N+PE	L+N+PE
±0.5KV	✓	✓	✓	✓	✓	✓	✓
±1KV	✓	✓	✓	✓	✓	✓	✓
±2KV	✓	✓	✓	✓	✓	✓	✓

Signal Control Line :

TEST VOLTAGE	PERFORMACE CRITERIA
±0.25KV	✓
±0.5KV	✓
±1KV	✓

8.1 Model : CHB001HT

8.2 Final Result : PASSED

8.3 Remark :

9 Photos of test configuration please refer to appendix A.

SURGE IMMUNITY TEST

1 TEST INSTRUMENTS & FACILITIES

Instruments/ Facilities	Manufacturer	Model # Serial #	Data Of Cal.
SURGER-TESTER	HAEFELY	PSURGE 4010 583334-38	FEB/2007
CONTROL PC	KB TECH	KB P586/133	--

2 TEST PROCEDURE

According To **IEC 61000-4-5 (2001)**

According To **EN 50130-4 (1995) + A1 (1998) + A2 (2003)**

3 TEST SETUP

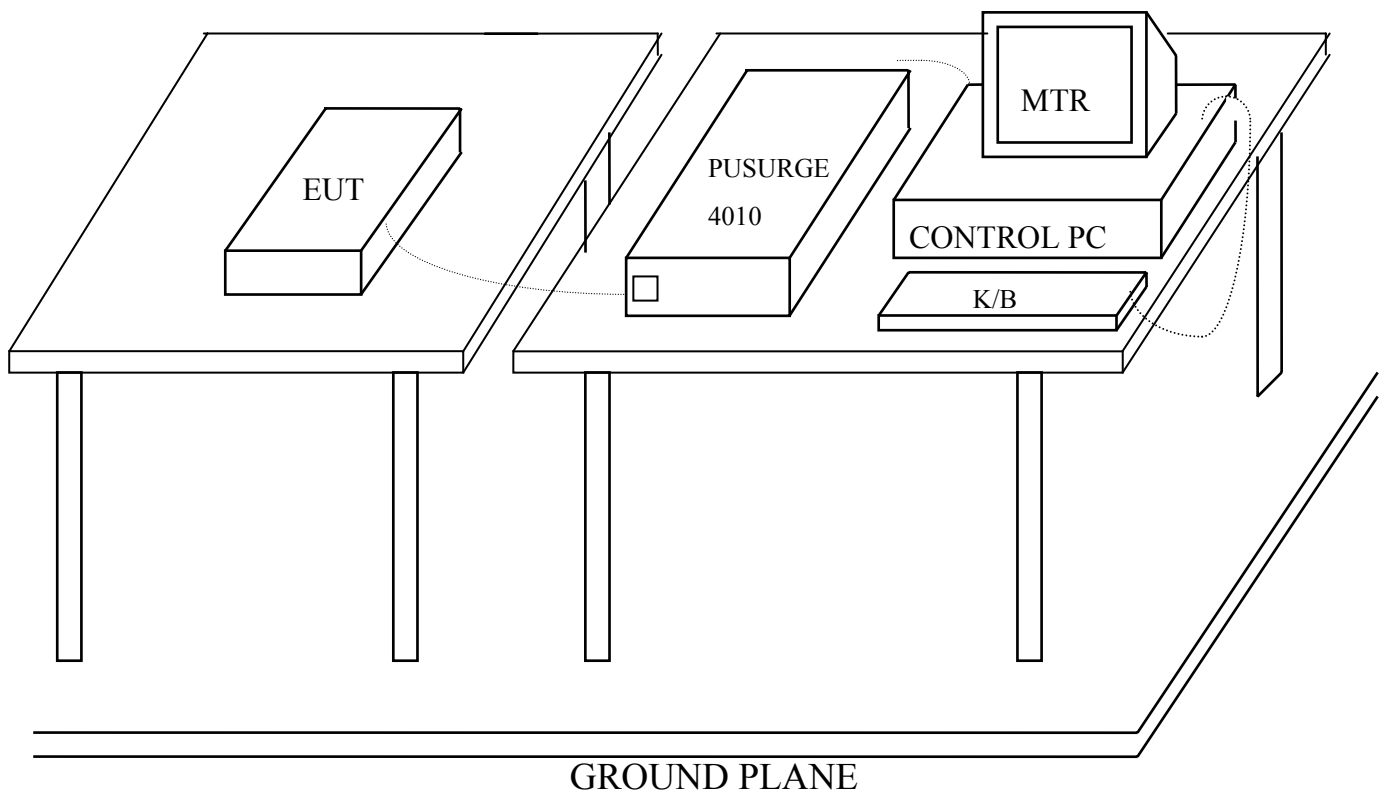

(Details for setup configuration, please refer to appendix A.)

4 TEST LEVELS

- Input and Output AC Power Ports.
- DC Input and DC Output Power Ports.

Environmental Phenomena	Test Specification		Units
	AC	DC	
Test voltage ¹⁾ :			
a.c. mains supply lines:			
Line to Line	±0.5, 1	N/A	KV (Charge Voltage)
Line to ground ²⁾	±0.5, 1, 2	N/A	KV (Charge Voltage)
other supply / signal lines: ³⁾			
Line to ground ⁴⁾	N/A	±0.5, 1	KV (Charge Voltage)
Polarity	+ and -		
Minimum number of surges at each polarity, voltage, coupling mode and line:			
a.c. mains supply lines	20 ⁵⁾		
Other supply / signal lines	5		
<p>1) The test voltages specified are the open-circuit voltages. The test voltages for the lower severity levels are included, because all the lower severity levels must also be satisfied.</p> <p>2) Via a 10Ω series resistor.</p> <p>3) No test is required where the manufacturer’s specification indicates that it is not permitted to connect cables >30m long.</p> <p>4) Via a 40Ω series resistor.</p> <p>5) Five at each zero-crossing point and at the maximum and minimum points on the mains voltage wave.</p>			

5 CONFIGURATION OF THE EUT

Same as “Conducted Power Line test”, section 4

6 EUT OPERATION CONDITION

Same as “Conducted Power Line test”, section 5

7 CONDITIONS DURING TESTING

7.1 Coupling of power line :

- (A) Line to Line $\pm 0.5\text{KV}$, $\pm 1\text{KV}$ (AC)
- (B) Line to Earth $\pm 0.5\text{KV}$, $\pm 1\text{KV}$, $\pm 2\text{KV}$ (AC)
- (C) Line to Ground $\pm 0.5\text{KV}$, $\pm 1\text{KV}$ (DC)

7.2 Test Voltage of Signal Control Line : $\pm 0.5\text{KV}$, $\pm 1\text{KV}$ (AC)

7.2 Polarity : POSITIVE / NEGATIVE

7.3 Phase shifting in a range between 0° to 360°

7.4 Repetition rate at least 1 per min

7.5 Test times on ac mains supply lines :

5 at each zero-crossing point and at the maximum and minimum point on the mains voltage wave.

7.6 Test times on signal lines : 5

7.7 Temperature : 23 °C ($15^\circ\text{C} \sim 35^\circ\text{C}$)

Humidity : 55 % RH. ($10\% \sim 75\%$)

8 PERFORMANCE CRITERIA

There shall be no damage, malfunction or change of status due to the conditioning. Flickering of an indicator during the application of the surges is permissible, providing that there is no residual change in the EUT or any change in outputs, which could be interpreted by associated equipment as a change.

The EUT shall meet the acceptance criteria for the functional test, after the conditioning.

9 TEST RESULT

Power Line :

Environmental Phenomena	Test Specification	Units
Line to Line	$\pm 0.5, 1$	KV (Charge Voltage)
Line to Earth	$\pm 0.5, 1, 2$	KV (Charge Voltage)

Signal Control Line :

Environmental Phenomena	TEST VOLTAGE	Units
Video Output	$\pm 0.5, 1$	KV (Charge Voltage)

9.1 Model : CHB001HT

9.2 Final Result : PASSED

9.3 Remark :

10 Photos of test configuration please refer to appendix A.

IMMUNITY TEST TO CS CONDUCTED DISTURBANCE

1 TEST INSTRUMENTS & FACILITIES

Instruments/ Facilities	Manufacturer	Model # Serial #	Date Of Cal.
SIGNAL GENERATOR	ROHDE & SCHWARZ	SMY02 845181/025	MAR/2007
AMPLIFIER	AMPLIFIER RESEARCH	75A250 25680	N/A
RF VOLTMETER	BOONTON	9200C 361701AA	MAR/2007
RF PROBE	BOONTON	952001B 37082	MAR/2007
DIRECTION COUPLER	AMPLIFIER RESEARCH	DC2600 20508	N/A
COUPLING DECOUPLING NETWORK	FCC	FCC-801-M3-25A 9993	FEB/2007
CONTROL PC	KB TECH	KB P586/133	--

2 TEST PROCEDURE

According To **ENV 50141 (1993)**

According To **EN 50130-4 (1995) + A1 (1998) + A2 (2003)**

3 TEST SETUP

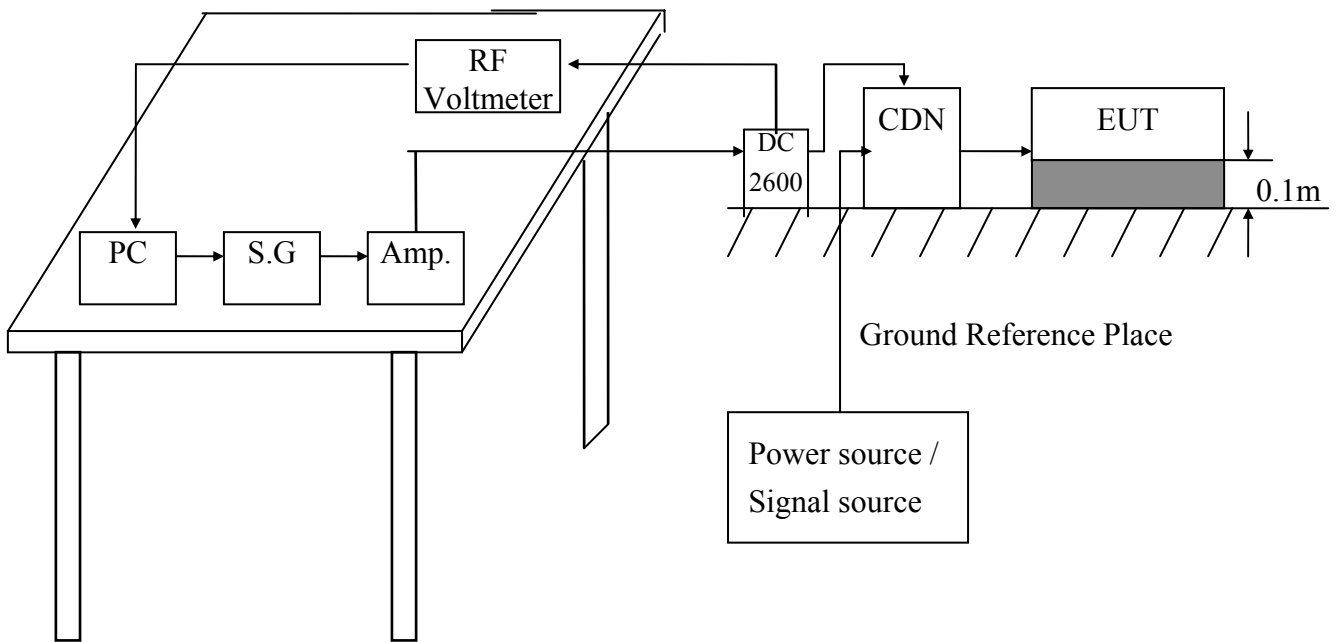

(Details for setup configuration, please refer to appendix A.)

4 TEST LEVELS

- Ports for signal lines and control lines.
- DC input and DC output power ports.
- Input and Output AC Power Ports.
- Functional earth Ports.

Environmental	Test Specification	Units
Radio-frequency	0.15 - 100	MHz
Common mode	10	V
Amplitude Modulation	80	% (1KHz)
Pulse Modulation	1	Hz (0.5s on : 0.5s off)

5 CONFIGURATION OF THE EUT

Same as “Conducted Power Line test”, section 4

6 EUT OPERATION CONDITION

Same as “Conducted Power Line test”, section 5

7 CONDITIONS DURING TESTING

7.1 The EUT tested type :

- Single unit
- Multiple unit

7.2 Dwell time : < 3 Seconds

7.3 Step size : < 1%

7.4 Test times : 3 times (pulse modulation)

7.5 Temperature : 23 °C (15°C ~ 35°C)

Humidity : 55 % RH.(10 % ~ 75%)

8 PERFORMANCE CRITERIA

There shall be no damage, malfunction or change of status due to the conditioning. Flickering of an indicator during the conditioning is permissible, providing that there is no residual change in the EUT or any change in outputs, which could be interpreted by associated equipment as a change, and no such flickering of the picture is allowed at 10V, providing :

- a There is no permanent damage or change to the EUT (e.g. no corruption of memory or changes to programmable settings etc.);
- b At $U_0 = 3V$, any deterioration of the picture is so minor that the system could still be used;
- c There is no observable deterioration of the picture at $U_0 = 1V$.

The EUT shall meet the acceptance criteria for the functional test, after the conditioning.

9 TEST RESULT

TEST Specification	Unit
0.15 - 100	MHz
10	V
80	% (1KHz)
1	Hz (0.5s on : 0.5s off)

9.1 Model : CHB001HT

9.2 Final Result : PASSED

9.3 Remark :

10 Photos of test configuration please refer to appendix A.

VOLTAGE DIPS, SHORT INTERRUPTIONS IMMUNITY TEST AND MAIN SUPPLY VARIATIONS

1 TEST INSTRUMENTS & FACILITIES

Instruments/ Facilities	Manufacturer	Model # Serial #	Data Of Cal.
LINE INTERFERENCE -TESTER	HAEFELY	PLINE 1610 080166-10	FEB/2007
CONTROL PC	KB TECH	KB P586/133	--
FREQUENCY CONVERTER	EXTECH	CFC-130	--
DIGITAL MULTIMETER	ESCORT	EDM-88 30802175	AUG/2006

2 TEST PROCEDURE

According To **IEC 61000-4-11 (2004)**

According To **EN 50130-4 (1995) + A1 (1998) + A2 (2003)**

3 TEST SETUP

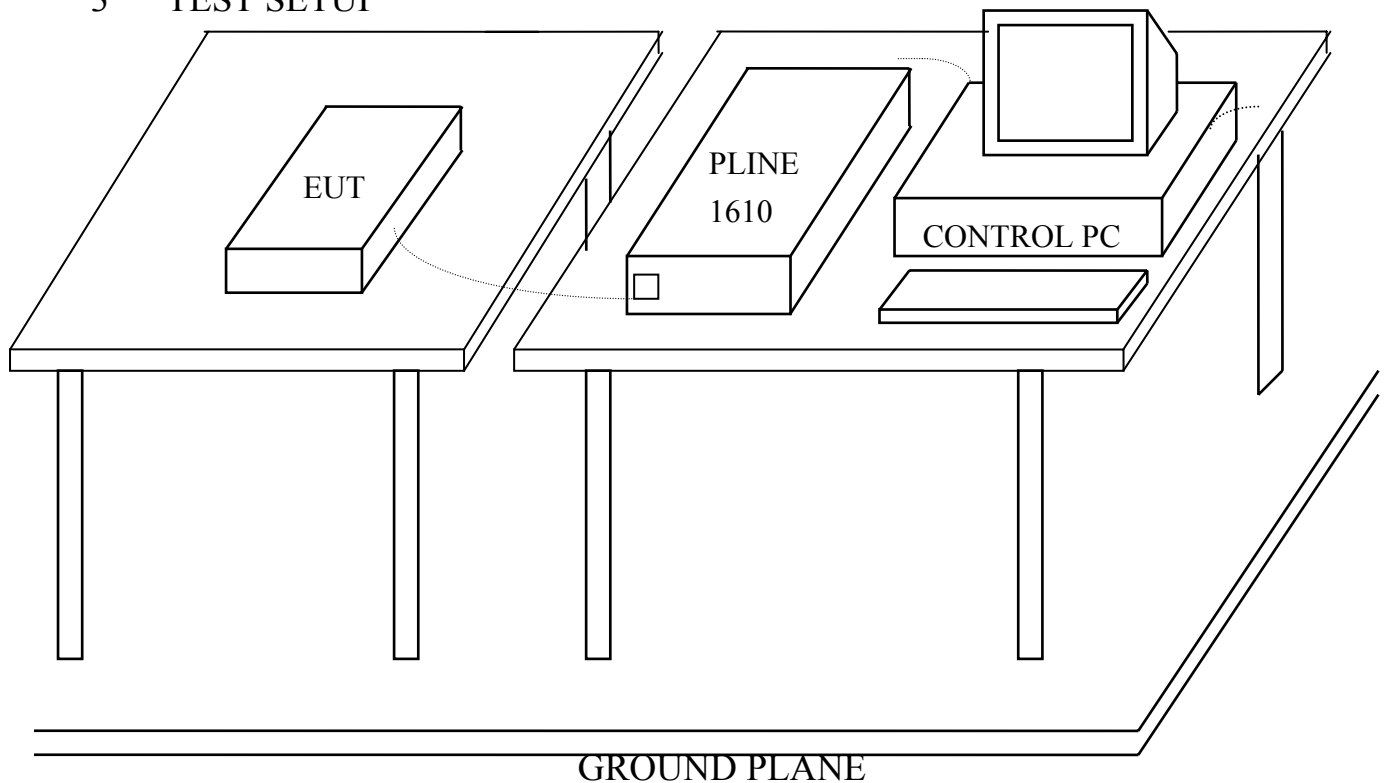

(Details for setup configuration, please refer to appendix A.)

4 TEST LEVELS FOR DIPS

Input and Output AC Power Ports.

- Voltage Dips.
- Voltage Interruptions.

Environmental Phenomena	Test Specification	Units
Voltage Dips	60 0.5, 1, 5, 10	% Reduction periods
	100 0.5, 1, 5	% Reduction periods
Interval between reductions	≥ 10	Second
Number of reduction at each duration	3 (Voltage Dip 60) 3 (Voltage Dip 100)	Times

5 CONFIGURATION OF THE EUT

Same as “Conducted Power Line test”, section 4

6 EUT OPERATION CONDITION

Same as “Conducted Power Line test”, section 5

7 CONDITIONS DURING TESTING

7.1 Temperature : 23 °C (15°C ~ 35°C)

Humidity : 55 % RH.(25 % ~ 75%)

8 PERFORMANCE CRITERIA

There shall be no damage, malfunction or change of status due to the conditioning. Flickering of an indicator during the conditioning is permissible, providing that there is no residual change in the EUT or any change in outputs, which could be interpreted by associated equipment as a change.

The EUT shall meet the acceptance criteria for the functional test, after the conditioning.

9 TEST RESULT

Same as “Voltage Dips, Short Interruptions Immunity Test and Main Supply Variations”, section 4

9.1 Model : CHB001HT

9.2 Final Results : PASSED

9.3 Remark

10 TEST LEVELS FOR MAIN SUPPLY VARIATIONS

Extreme Voltages		Voltage Applied	Perform Criteria
Supply voltage max (Umax)	Unom + 10%	253.0V	A
Supply voltage min (Umin)	Unom – 15%	195.5V	A

11 PERFORMANCE CRITERIA

- A. The apparatus or system shall continue to operate as intended while performs testing. No degradation of performance or loss of function is allowed below. No degradation or influence for display picture.
- B. The apparatus or system might have influence from electrical interference while testing, however there is normal operation after turn off electrical interference. It is allowance that is following phenomenon that is appeared while turn on the elector interference.
- C. The apparatus or system lost or temporary lost the function while performs the testing, it shall operate normally after turn off the elector interference or reset the apparatus main power.

12 TEST RESULT

Same as “Voltage Dips, Short Interruptions Immunity Test and Main Supply Variations”, section 10

12.1 Model : CHB001HT

12.2 Final Results : PASSED

12.3 Remark

13 Photos of test configuration please refer to appendix A.



HomeTek Technology Inc.

Appendix A

PHOTOS OF TEST CONFIGURATION

PHOTO OF CONDUCTED POWER LINE TEST

Model : CHB001HT



Front View



Rear View

PHOTO OF RADIATED EMISSION TEST

Model : CHB001HT ;CHB001HR



Front View



Rear View

**PHOTO OF HARMONICS & VOLTAGE FLUCTUATIONS TEST
AND SURGE IMMUNITY TEST AND VOLTAGE DIPS, SHORT
INTERRUPTIONS IMMUNITY TEST**

Model : CHB001HT



**PHOTO OF ELECTRICAL FAST TRANSIENT/BURST IMMUNITY
TEST**



PHOTO OF ELECTROSTATIC DISCHARGE IMMUNITY TEST (ESD)

Model : CHB001HT



PHOTO OF POWER FREQUENCY MAGNETIC FIELD IMMUNITY TEST



PHOTO OF RADIO FREQUENCY ELECTROMAGNETIC FIELD IMMUNITY TEST (RS)

Model : CHB001HT



PHOTO OF CS CONDUCTED DISTURBANCE IMMUNITY TEST





HomeTek Technology Inc.

Appendix B

PHOTOS OF EUT

PHOTO OF EUT



Full View of EUT(Model : CHB001HR)

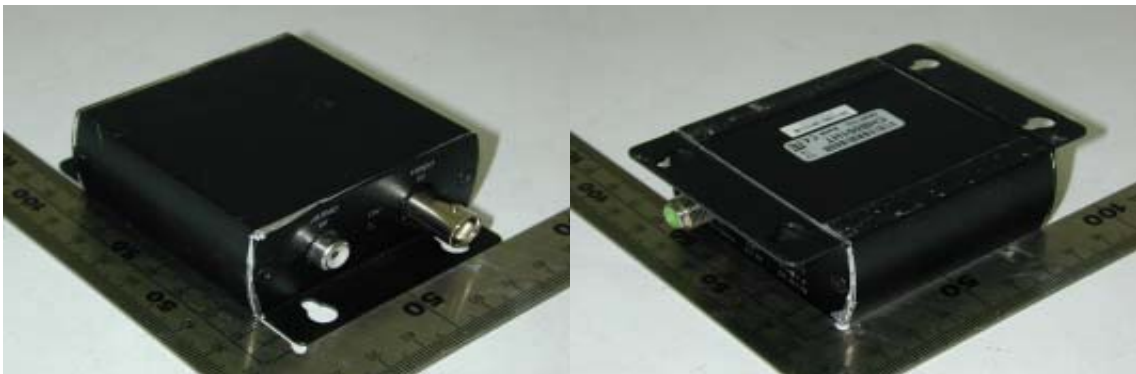

Full View of EUT(Model : CHB001HT)

PHOTO OF EUT



Full View of EUT(Model : CHB001HR)



Full View of EUT(Model : CHB001HT)

PHOTO OF EUT

Model : CHB00XXXR

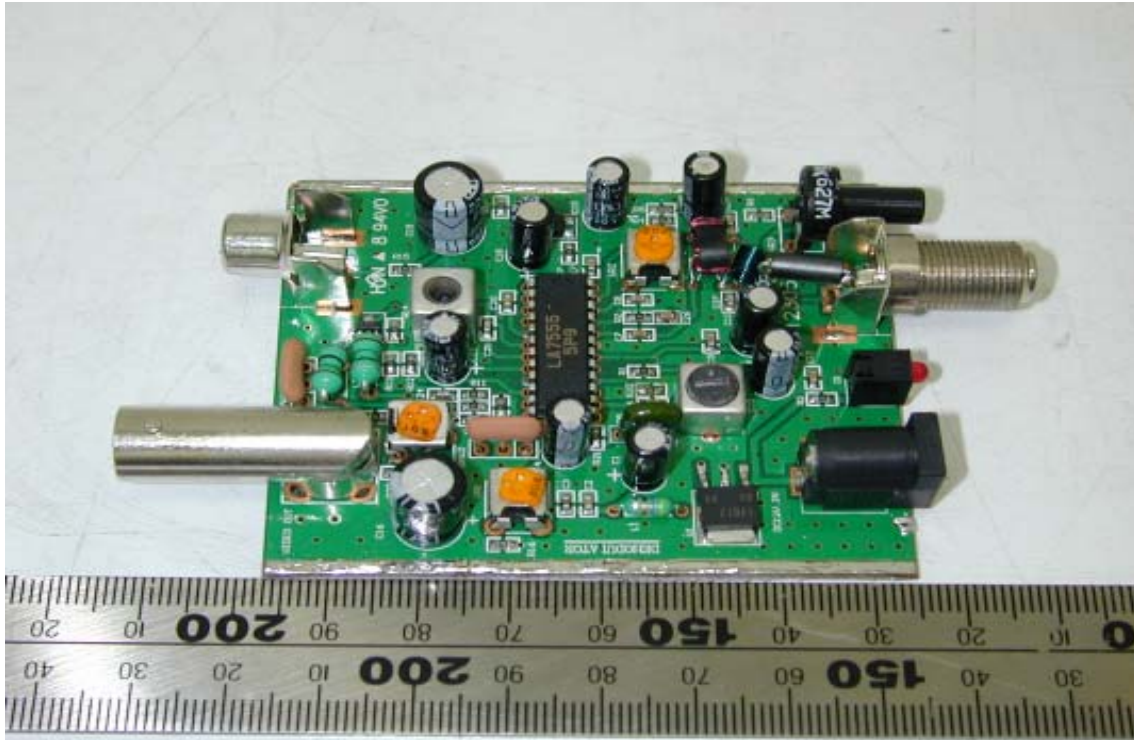

Component Side of Main Board 1

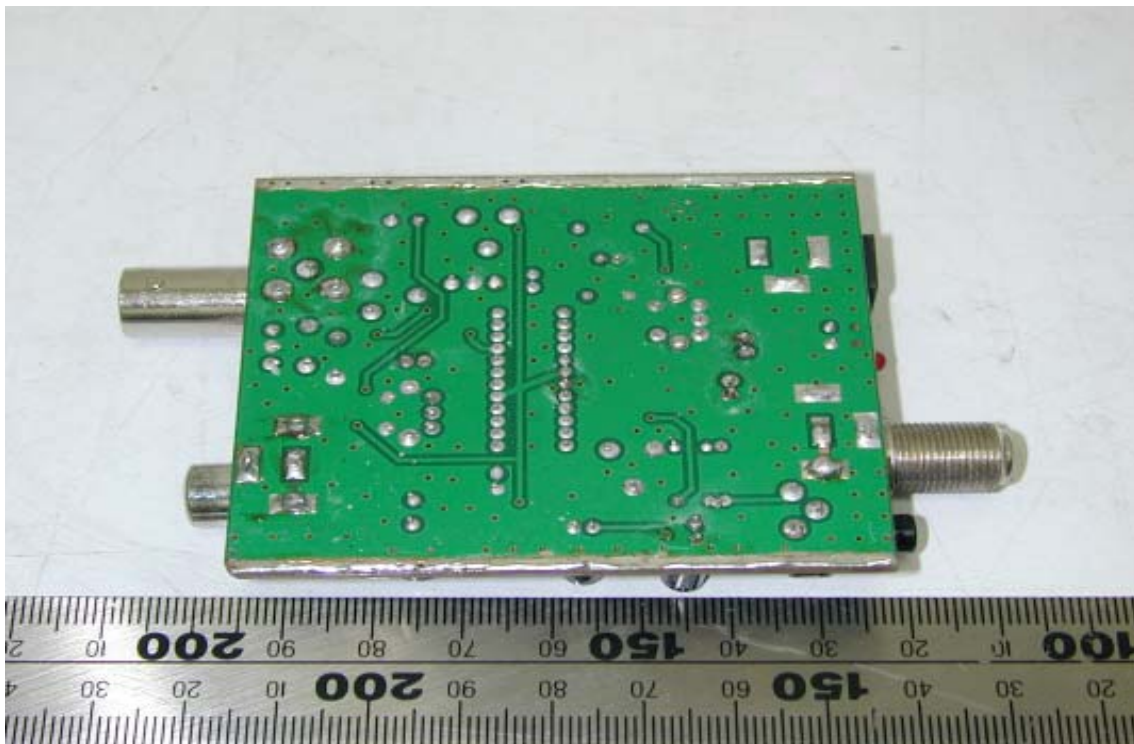

Solder Side of Main Board 1

PHOTO OF EUT

Model : CHB00XXXT

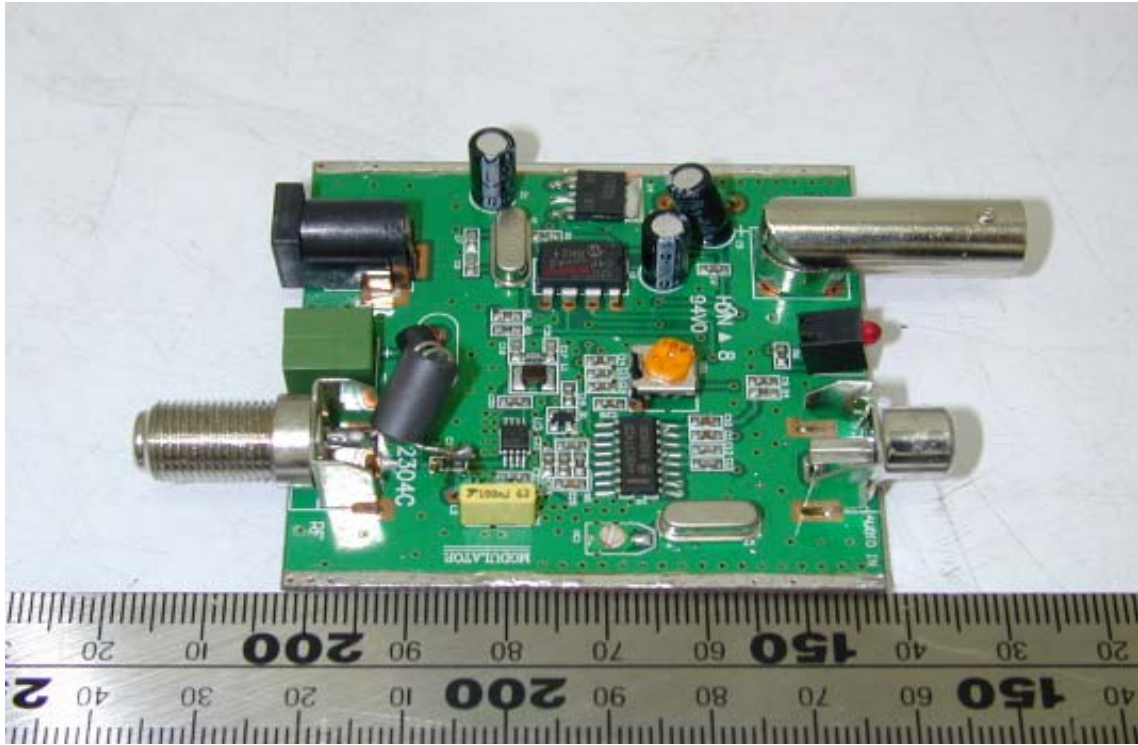

Component Side of Main Board 2

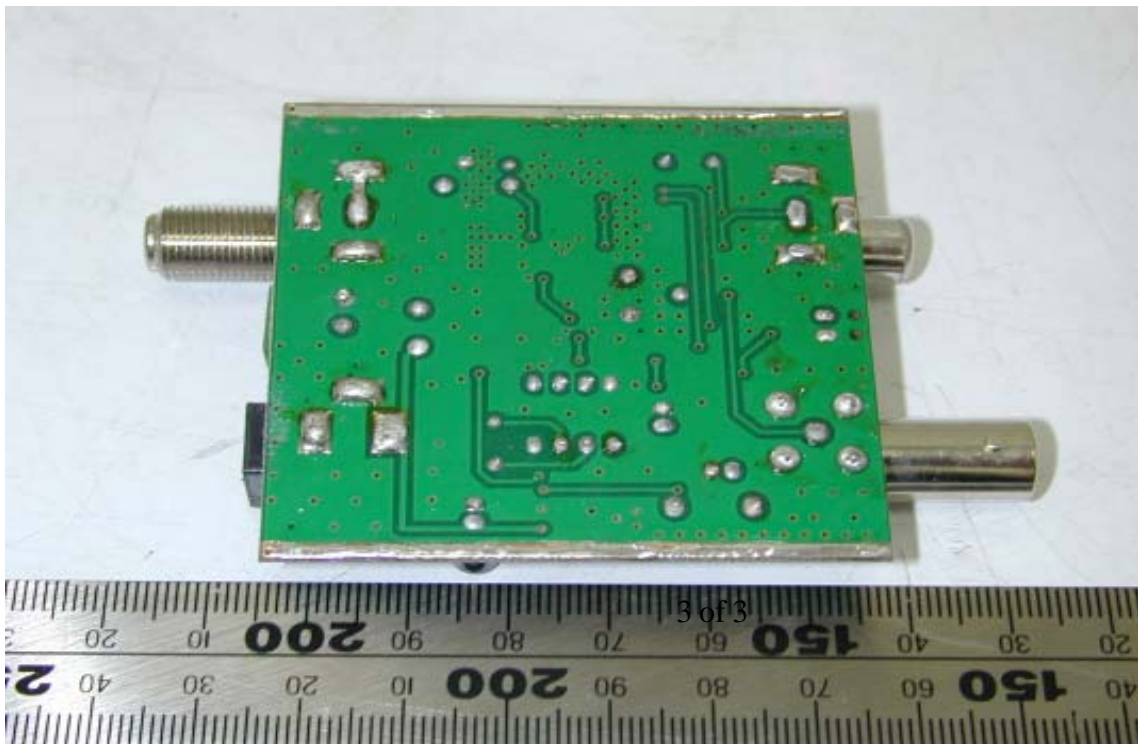

Solder Side of Main Board 2

PHOTO OF EUT



Front View of Adapter (Model : ADP12500N-2)



Rear View of Adapter (Model : ADP12500N-2)

Declaration of Conformity

We(Manufacturer/Importer)

(company name)

(address)

declares under our sole responsibility that the product

Product name : Hi Frequency Interference Blocker

Model No. : CHB00XXXT, CHB00XXXR

to which this declaration relates is in conformity with the following standard(s) or other normative document(s)

- | | |
|-------------------------------------------------------------|-------------------------------------------------------------------------------------|
| <input checked="" type="checkbox"/> EN 61000-6-3 (2001) | <input checked="" type="checkbox"/> EN 50130-4 (1995)
+ A1 (1998)
+ A2 (2003) |
| <input checked="" type="checkbox"/> CISPR 22 Class B (1997) | <input checked="" type="checkbox"/> IEC 61000-4-2 (2001) |
| <input checked="" type="checkbox"/> EN 61000-3-2 (2000) | <input checked="" type="checkbox"/> IEC 61000-4-3 (2002) |
| <input checked="" type="checkbox"/> EN 61000-3-3 (1995) | <input checked="" type="checkbox"/> IEC 61000-4-4 (2004) |
| + A1 (2001) | <input checked="" type="checkbox"/> IEC 61000-4-5 (2001) |
| | <input checked="" type="checkbox"/> ENV 50141 (1993) |
| | <input checked="" type="checkbox"/> IEC 61000-4-11 (2004) |

following the provisions of 2004/108/EC Directive

Place: _____ Signature: _____

Date : _____ Full name: _____



Title: _____



TÜV Rheinland Taiwan Ltd.

Certificate

of

Appointment

for the applicant:

Hometek Technology Inc.
No. 67-9, Shir Men Rd., Tu-Cheng City,
Taipei Hsien 236, Taiwan, R.O.C.

has been authorized to carry out EMC tests by order and under supervision of TÜV Rheinland. It has successfully demonstrated capability to conduct measurement and to process test data according to:

**European and International EMC Standards as listed in the
Scope of Authorization on the attachment to this certificate**

An assessment of the facility was conducted by TÜV Rheinland auditors according to the TÜV Rheinland requirements for "Test Site Approval" with reference to

ISO 17 025:1999

Certificate No. : 10012161-2006

Valid until : June 14, 2007

TÜV Rheinland Taiwan Ltd.
Taipei, April 13, 2006

Dipl.-Ing. Andreas Klinker
Certification Body

Dipl.-Ing. Bodo Kretzschmar
Product Safety and Quality



Attachment to
Certificate
of Appointment

SCOPE OF AUTHORIZATION

Hometek Technology Inc.
No. 67-9, Shir Men Rd., Tu-Cheng City,
Taipei Hsien 236, Taiwan, R.O.C.

European Standards

EN 50081-1	EN 61000-3-2	ENV 50140
EN 50081-2	EN 61000-3-3	ENV 50141
EN 50082-1	EN 61000-6-1	ENV 50204
EN 50130-4	EN 61000-6-2	
EN 50091-2	EN 61000-6-3	
EN 55011	EN 61000-6-4	
EN 55013	EN 61000-3-11	
EN 55014-1	EN 61000-4-2	
EN 55014-2	EN 61000-4-3	
EN 55022	EN 61000-4-4	
EN 55024	EN 61000-4-5	
EN 60601-1-2	EN 61000-4-6	
EN 60801	EN 61000-4-8	
EN 60945	EN 61000-4-11	
	EN 61204-3	

International Standards

CISPR 11	IEC 61000-4-2	IEC 61000-3-2
CISPR 13	IEC 61000-4-3	IEC 61000-3-3
CISPR 14-1	IEC 61000-4-4	IEC 61000-3-11
CISPR 14-2	IEC 61000-4-5	IEC 61000-6-1
CISPR 22	IEC 61000-4-6	IEC 61000-6-2
CISPR 24	IEC 61000-4-8	IEC 61000-6-3
	IEC 61000-4-11	IEC 61000-6-4
IEC 801.2	IEC 61000-4-12	IEC 60945
IEC 801.3		
IEC 801.4		

Certificate No. : 10012161-2006

Taipei, April 13, 2006

Dipl.-Ing. Bodo Kretzschmar
Product Safety and Quality