



FCC COMPLIANCE TEST REPORT

Technical Statement of Conformity
in accordance with **FCC Part 15 Subpart B**

The product

Equipment Under Test	: HDMI CAT5 Extender Series
Model Number	: HE0XXXXT
Product Series	: N/A
Report Number	: HA110436-FD
Issue Date	: 13-DEC-2011
Test Result	: Compliance

is produced by

SMART HOME ENGINEERING CORP.

10F, No.493, Chung-Cheng Rd., Hsin Tien City, Taipei County, 231, Taiwan



HongAn TECHNOLOGY CO., LTD.

NO.15-1, CWEISHUH KENG, CWEIPIN VILLAGE,
LINKOU DIST.,NEW TAIPEI CITY ,
TAIWAN, R. O. C.

TEL: +886-2-26030362

FAX: +886-2-26019259

E-mail: hatlab@ms19.hinet.net

BSMI Registration No.: SL2-IN-E-0023, SL2-A1-E-0023,
SL2-IS-E-0023, SL2-R1-E-0023,
SL2-R2-E-0023, SL2-L1-E-0023

FCC Designation No.: TW1001

Nemko Authorization No.: ELA184

TAF Accreditation No.: 1163

VCCI Registration No.: R-2156, C-2329, T-219

Contents

1	General Description	5
1.1	Description of EUT	5
1.2	Test Instruments	6
1.3	Auxiliary Equipments	7
1.4	EUT SETUP	7
1.5	Identifying the Final Test Mode	8
1.6	Final Test Mode	8
1.7	Condition of Power Supply	8
1.8	EUT Configuration	8
1.9	Qualification of Test Facility	8
2	Conducted Disturbance Emission Test	9
2.1	Test Instruments	9
2.2	Test Arrangement and Procedure	9
2.3	Conducted Disturbance Limit	10
2.4	Test Result	10
3	Radiated Disturbance Emission Test	13
3.1	Test Instruments	13
3.2	Test Arrangement and Procedure	13
3.3	Radiated Disturbance Limit	14
3.4	Test Result	14
4	Photographs of the Tests	17
4.1	Conducted Disturbance Emission Test	17
4.2	Radiated Disturbances Emission Test	18
5	Photographs of the EUT	19
5.1	RX	19
5.2	TX	23

Verification

Applicant : SMART HOME ENGINEERING CORP.

Address of Applicant : 10F, No.493, Chung-Cheng Rd., Hsin Tien City, Taipei
County, 231, Taiwan

Manufacturer : SMART HOME ENGINEERING CORP.

Address of Manufacturer : 10F, No.493, Chung-Cheng Rd., Hsin Tien City, Taipei
County, 231, Taiwan

Equipment Under Test : HDMI CAT5 Extender Series

Model Number : HE0XXXXT

Product Series : N/A

Sample Received Date : 02-DEC-2011

Test Standard :

<p>Emission:</p> <p><input checked="" type="checkbox"/> FCC Part 15 : Subpart B (10-1-10 Edition) Class B</p> <p><input checked="" type="checkbox"/> CISPR 22 : 2008 (Edition 6.0) Class B</p>

Deviations from standard test methods & any other specifications : NONE

Remark:

1. This report details the results of the test carried out on one sample.
2. The test result is deemed satisfactory evidence of compliance with ICES-003.
3. This report applies to the above sample only and shall not be reproduced in part without written approval of HongAn Technology Co., Ltd.

Documented by: _____
Zoe Chen / ADM. Dept Staff

Tested by: _____
M.S.SHI / ENG. Dept. Staff

Approved by: _____
Peter Chin / Section Manager

Date: 2011-12-13

Summary of Test Result

Emission			
Test Standard	Test Item	Test Result	Remark
FCC Part15 Subpart B, CISPR22 Class B	Conducted Disturbance	Compliance	Highest Emission: LINE: 5.88 MHz, 38.61 dBuV (Average) Margin -11.39 dB.
FCC Part15 Subpart B, CISPR22 Class B	Radiated Disturbances	Compliance	Highest Emission: Vertical: 39.98 MHz, 26.23 dBuV (Quasi-Peak), Margin -3.77 dB, Antenna Height 100 cm, Turntable Angle 66 °.

1.2 Test Instruments

1.2.1. Instruments Used for Emission Measurement

Instrument Name	Manufacture Mode	Model Number	Serial Number	Last Cal. Date	Next Cal. Date	Test Item
LISN	EMCO	3810/2NM	9702-1820	30-Sep-2011	29-Sep-2012	Conducted Emission
LISN	Rolf Heine Hochfrequenz technik	NNB-4/32T	00001	17-FEB-2011	17-FEB-2012	Conducted Emission
RF Current Probe	FCC	F-33-4	53	02-MAY-2011	01-MAY-2012	Conducted Emission
Impedance Stabilization Network (ISN)	SCHAFFNER	ISN T400	16832	08-OCT-2011	08-OCT-2012	Conducted Emission
EMI Test Signal Analyzer	PMM	PMM 9000	4410J10302	05-AUG-2011	04-AUG-2012	Conducted Emission, Radiation Emission
Spectrum Analyzer	ADVANTEST	R3172	101202158	15-AUG-2011	14-AUG-2012	Radiated Emission
Preamplifier	CHASE	CPA 9231A	3310	08-JUL-2011	07-JUL-2012	Radiated Emission
Preamplifier	HD	HD17187	004	23-Aug-2011	22-Aug-2012	Radiated Emission
Bilog Antenna	CHASE	CBL 6112B	2860	17-AUG-2011	16-AUG-2012	Radiated Emission
Double-Ridged Waveguide Horn	EMCO	3115	9912-5992	02-MAY-2011	01-MAY-2012	Radiated Emission

※ The test equipments used are calibrated and can be traced to National ITRI and International Standards.

1.3 Auxiliary Equipments

1.3.1. Provided by HongAn Technology Co., Ltd. for Emission Test.

No.	Equipment	Model No.	Serial No.	EMC Approved	Brand	Description	
						Data Cable	Power Cable
L1	DVD Player	DVP-NS708HP	5205154	R33021	Sony	N/A	Unshielded,1.3m
E3	Monitor	SP2208WFpT	CN-0PK573-71618 -86A-287U-A02	CE Mark, FCC DoC	DELL	HDMI Cable Shielded (Braid),1.5m	Unshielded, 1.8m

1.3.2. Provided by the Manufacturer

No.	Equipment	Model No.	Serial No.	EMC Approved	Brand	Description	
						Data Cable	Power Cable
N/A	N/A	N/A	N/A	N/A	N/A	N/A	N/A

1.4 EUT SETUP

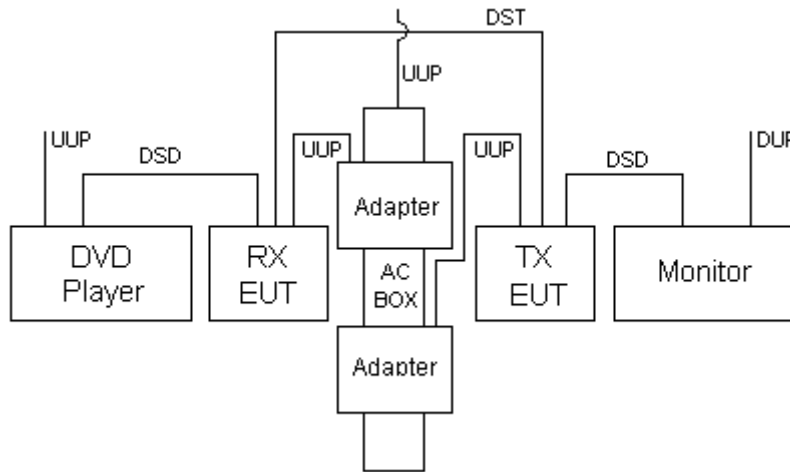

Note:

1. Main Test Sample: HE0XXXXT
The series products were not tested.
2. I/O Port Setup

Type of Port	Total Q'ty	Test Status
HDMI IN Port	1	Operating 1
HDMI OUT Port	1	Operating 1
LAN Port	1	Operating 1
Power Port	2	Operating 2

3. Legend:

UUD : Undetachable Unshielded Data cable.	UUP : Undetachable Unshielded Power cord.
USD : Undetachable Shielded Data cable.	USP : Undetachable Shielded Power cord.
DSD : Detachable Shielded Data cable.	DUP : Detachable Unshielded Power cord.
DUD : Detachable Unshielded Data cable.	DSP : Detachable Shielded Power cord.
UTP : Unshielded Data Twisted Pair Cable.	STP : Shielded Data Twisted Pair Cable.

1.5 Identifying the Final Test Mode

1. Operation Mode 1: Play DVD Movie

Note: After pre-test, we identified that the Operation Mode 1 (the worst case) was most likely to cause maximum disturbance and most likely to be susceptible to disturbance. Therefore, the Final EMC Assessment was performed for the worst case. All pre-test data show at appendix.

1.6 Final Test Mode

Operation Mode 1: Play DVD Movie

1.7 Condition of Power Supply

AC 120 V; 60 Hz

1.8 EUT Configuration

1. Setup the EUT as shown in Sec.1.4 Block Diagram.
2. Turn on the power of all equipments.
3. Activate the selected Final Test Mode.

1.9 Qualification of Test Facility

BSMI Certificate No. : SL2-IS-E-0023, SL2-IN-E-0023, SL2-R1-E-0023, SL2-R2-E-0023,
SL2-A1-E-0023, SL2-L1-E-0023.

FCC Designation No. : TW1001

Nemko Authorization No. : ELA 184

TAF Accreditation No. : 1163

VCCI Certificate No. : R-2156, C-2329, T-219

2 Conducted Disturbance Emission Test

2.1 Test Instruments

Refer to Sec. 1.2 Test Instruments.

2.2 Test Arrangement and Procedure

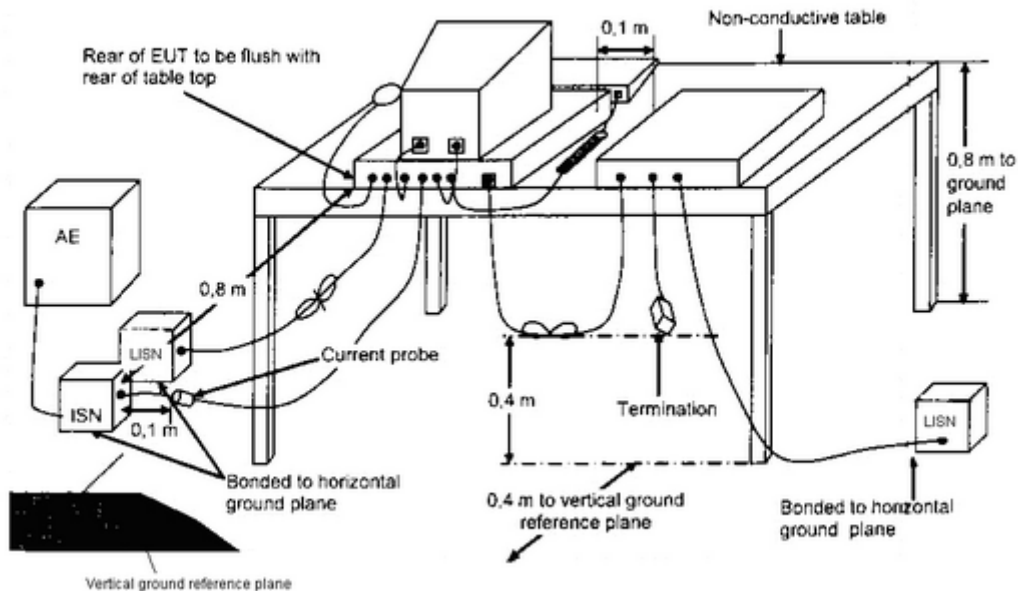

Table-top Equipment

- The EUT was placed on a non-conductive table which was 80 cm above the horizontal coupling plane. The rear of the EUT was 40 cm from the vertical coupling plane.
- The excess interface cables were folded at the cable center into a bundle no longer than 40 cm, so that the bundles were on the table.
- The EUT was connected to the main power through a L.I.S.N. This set up provided 50 ohm / 50 μ H coupling impedance for the measuring equipment.
- All auxiliary equipment received power from a second L.I.S.N.
- The conducted emissions were measured between the Line Phase and the PE ground and between the Neutral Phase and the PE ground using an EMI Receiver.
- The values were recorded.

2.3 Conducted Disturbance Limit

CISPR 22 / FCC Part 15 Subpart B

Frequency (MHz)	<input type="checkbox"/> Class A		<input checked="" type="checkbox"/> Class B	
	Q.P. (Quasi-Peak)	A.V. (Average)	Q.P. (Quasi-Peak)	A.V. (Average)
0.15 ~ 0.50	79	66	66 to 56	56 to 46
0.50 ~ 5.0	73	60	56	46
5.0 ~ 30	73	60	60	50

2.4 Test Result

Compliance

The final test data are shown on the following page(s).

Conducted Disturbance Emission Test Data

Test Date : 09-DEC-2011 Tested by : M.S.SHI
 Temp. : 22 °C Humidity : 51 %
 Power Mains : 120V/60Hz Power Line : LINE
 Description : N/A

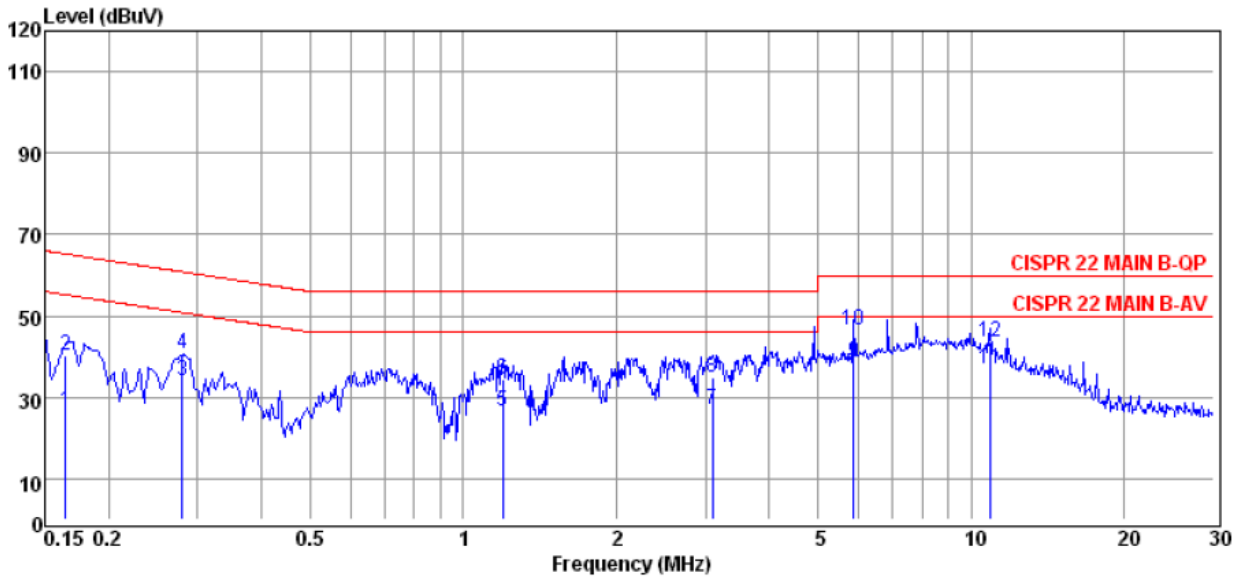

No.	Freq MHz	Reading dBµV	C.F dB	Result dBµV	Limit dBµV	Margin dB	Power Line	Remark
1	0.17	26.00	0.40	26.40	55.21	-28.81	LINE	Average
2	0.17	40.00	0.40	40.40	65.21	-24.81	LINE	QP
3	0.28	33.50	0.37	33.87	50.82	-16.95	LINE	Average
4	0.28	40.30	0.37	40.67	60.82	-20.15	LINE	QP
5	1.20	26.10	0.47	26.57	46.00	-19.43	LINE	Average
6	1.20	33.80	0.47	34.27	56.00	-21.73	LINE	QP
7	3.09	26.30	0.58	26.88	46.00	-19.12	LINE	Average
8	3.09	34.30	0.58	34.88	56.00	-21.12	LINE	QP
9	5.88	37.90	0.71	38.61	50.00	-11.39	LINE	Average
10	5.88	45.60	0.71	46.31	60.00	-13.69	LINE	QP
11	10.91	36.20	0.91	37.11	50.00	-12.89	LINE	Average
12	10.91	42.70	0.91	43.61	60.00	-16.39	LINE	QP

- Peak, Average and QP signifies the measurement detector used for performing measurements.
- Negative number in the margin column indicates the amount (in dB) that the recorded emission is below the limit.
- P denotes Phase, N denotes Neutral, AV denotes Average, QP denotes Quasi-Peak.
- Corr. Factor = Insertion loss(LISN Factor)+ Cable loss.
- Margin value = (Measured+ Corr. Factor) – limit value.

Conducted Disturbance Emission Test Data

Test Date : 09-DEC-2011 Tested by : M.S.SHI
 Temp. : 22 °C Humidity : 51 %
 Power Mains : 120V/60Hz Power Line : Neutral
 Description : N/A

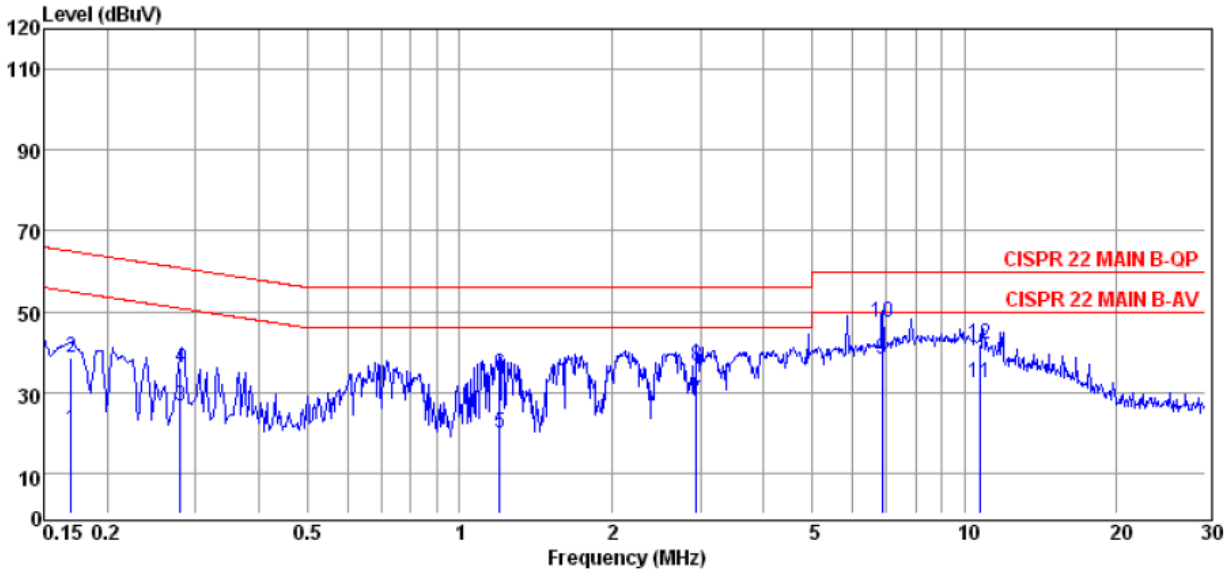

No.	Freq MHz	Reading dBμV	C.F dB	Result dBμV	Limit dBμV	Margin dB	Power Line	Remark
1	0.17	20.50	0.40	20.90	54.96	-34.06	NEUTRAL	Average
2	0.17	38.30	0.40	38.70	64.96	-26.26	NEUTRAL	QP
3	0.28	26.10	0.38	26.48	50.82	-24.34	NEUTRAL	Average
4	0.28	35.70	0.38	36.08	60.82	-24.74	NEUTRAL	QP
5	1.20	19.40	0.47	19.87	46.00	-26.13	NEUTRAL	Average
6	1.20	33.80	0.47	34.27	56.00	-21.73	NEUTRAL	QP
7	2.94	27.30	0.53	27.83	46.00	-18.17	NEUTRAL	Average
8	2.94	35.90	0.53	36.43	56.00	-19.57	NEUTRAL	QP
9	6.86	37.50	0.71	38.21	50.00	-11.79	NEUTRAL	Average
10	6.86	46.60	0.71	47.31	60.00	-12.69	NEUTRAL	QP
11	10.78	31.40	0.87	32.27	50.00	-17.73	NEUTRAL	Average
12	10.78	41.00	0.87	41.87	60.00	-18.13	NEUTRAL	QP

- Peak, Average and QP signifies the measurement detector used for performing measurements.
- Negative number in the margin column indicates the amount (in dB) that the recorded emission is below the limit.
- P denotes Phase, N denotes Neutral, AV denotes Average, QP denotes Quasi-Peak.
- Corr. Factor = Insertion loss(LISN Factor)+ Cable loss.
- Margin value = (Measured+ Corr. Factor) – limit value.

3 Radiated Disturbance Emission Test

3.1 Test Instruments

Refer to Sec. 1.2 Test Instruments.

3.2 Test Arrangement and Procedure

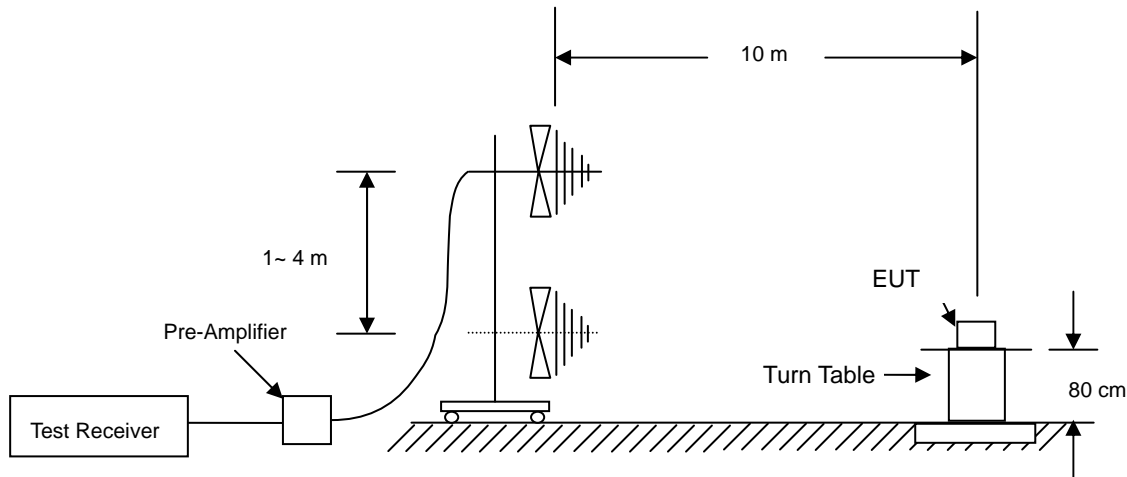

Table-top Equipment

- The EUT was placed on a non-conductive turntable which was 80 cm above the horizontal ground plane. The EUT was set 10 m away from the receiving antenna that was mounted on a non-conductive mast.
- Main cables draped to the ground plane and were routed to the mains power outlet. The mains power outlet was bonded to and did not protrude above the ground plane.
- The antenna was adjusted between 1 m and 4 m in height above the ground plane and the Antenna-to-EUT azimuth was also varied during the measurements to find the top 6 maximum meter readings within the frequency range limit as indicated in Sec 3.3.
- The radiated emissions were measured when the Antenna-to-EUT polarization was set horizontally and vertically.
- The values were recorded.

3.3 Radiated Disturbance Limit

FCC Part 15 Subpart B

Frequency (MHz)	<input type="checkbox"/> Class A (10m)		<input type="checkbox"/> Class B (3m)	
	Field Strength ($\mu\text{V/m}$)	Quasi-Peak ($\text{dB}\mu\text{V/m}$)	Field Strength ($\mu\text{V/m}$)	Quasi-Peak ($\text{dB}\mu\text{V/m}$)
30 ~ 88	90	39.08	100	40.00
88 ~ 216	150	43.52	150	43.52
216 ~ 960	210	46.44	200	46.02
Above 960	300	49.54	500	53.98

Emission Level ($\text{dB}\mu\text{V/m}$) = 20 Log Emission Level ($\mu\text{V/m}$)

CISPR 22

Frequency (MHz)	<input type="checkbox"/> Class A (10m)	<input checked="" type="checkbox"/> Class B (10m)
	Quasi-Peak ($\text{dB}\mu\text{V/m}$)	Quasi-Peak ($\text{dB}\mu\text{V/m}$)
30 ~ 230	40.0	30.0
230 ~ 1000	47.0	37.0

Frequency (GHz)	<input type="checkbox"/> Class A (3m)		<input type="checkbox"/> Class B (3m)	
	Average ($\text{dB}\mu\text{V/m}$)	Peak ($\text{dB}\mu\text{V/m}$)	Average ($\text{dB}\mu\text{V/m}$)	Peak ($\text{dB}\mu\text{V/m}$)
1 ~ 3	56	76	50	70
3 ~ 6	60	80	54	74

3.4 Test Result

Compliance

The final test data are shown on the following page(s).

Radiated Disturbance Emission Test Data- Horizontal

Test Date : 09-DEC-2011 Tested by : M.S.SHI
 Temp. : 23 °C Humidity : 51 %
 Description : N/A

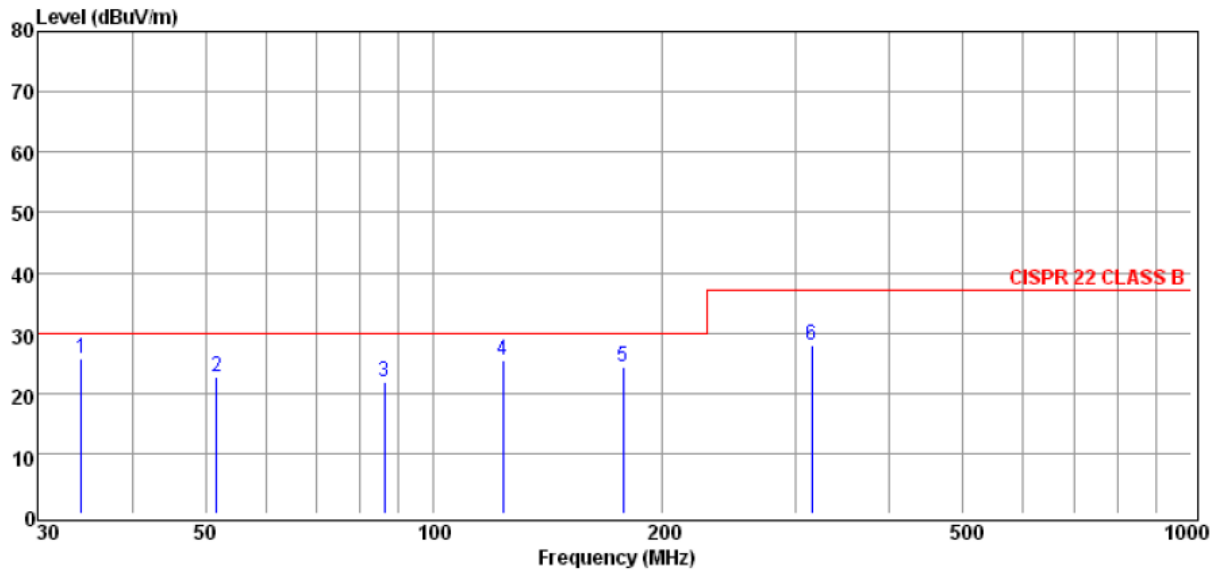

No.	Freq MHz	Reading dBμV	C.F dB	Result dBμV/m	Limit dBμV/m	Margin dB	Height cm	Angle deg	Antenna Pol.	Remark
1	34.23	39.03	-13.39	25.64	30.00	-4.36	400	100	HORIZONTAL	QP
2	51.69	44.19	-21.39	22.80	30.00	-7.20	400	104	HORIZONTAL	Peak
3	86.03	42.99	-20.99	22.00	30.00	-8.00	400	52	HORIZONTAL	Peak
4	123.46	42.38	-16.95	25.43	30.00	-4.57	398	96	HORIZONTAL	QP
5	177.68	44.02	-19.74	24.28	30.00	-5.72	395	35	HORIZONTAL	Peak
6	315.57	42.87	-14.98	27.89	37.00	-9.11	389	77	HORIZONTAL	Peak

- Negative number in the margin column indicates the amount (in dB) that the recorded emission is Below the limit.
- V means in Vertical Antenna Polarization, H means in Horizontal, and QP means in Quasi-Peak.
- Corrected Factor = Insertion loss (Antenna Factor) + Cable loss.
- Corrected Reading = Reading + Corrected Factor.
- Margin limit = Correction Reading - limit value.

Radiated Disturbance Emission Test Data- Vertical

Test Date : 09-DEC-2011 Tested by : M.S.SHI
 Temp. : 23 °C Humidity : 51 %
 Description : N/A

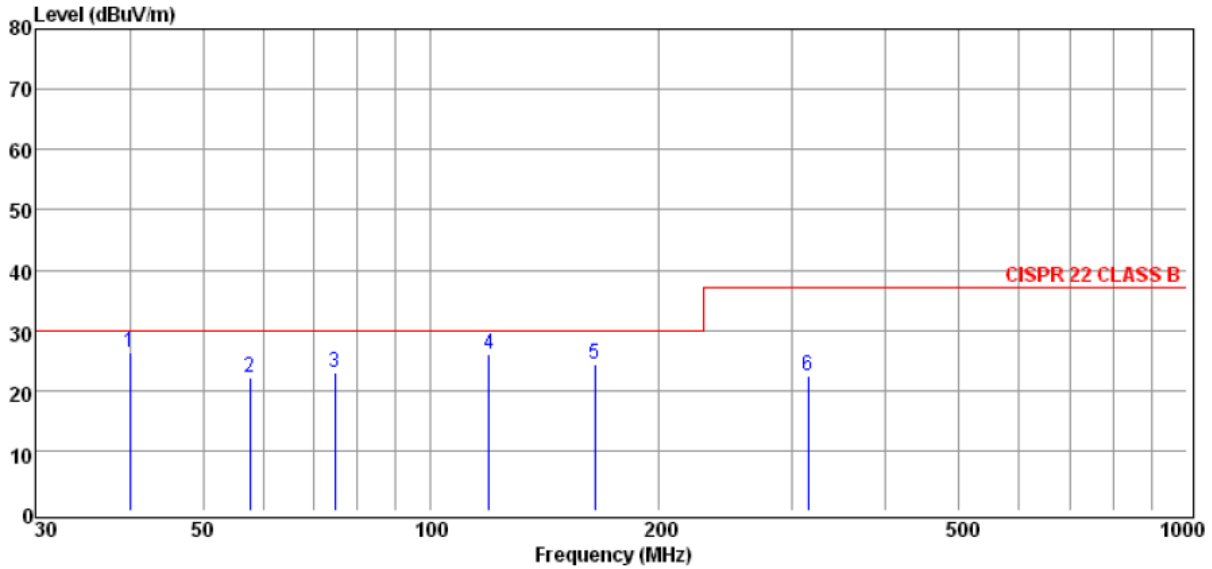

No.	Freq MHz	Reading dBµV	C.F dB	Result dBµV/m	Limit dBµV/m	Margin dB	Height cm	Angle deg	Antenna Pol.	Remark
1	39.98	43.04	-16.81	26.23	30.00	-3.77	100	66	VERTICAL	QP
2	57.61	44.65	-22.52	22.13	30.00	-7.87	100	181	VERTICAL	Peak
3	74.66	45.62	-22.53	23.09	30.00	-6.91	100	47	VERTICAL	Peak
4	119.46	42.95	-16.91	26.04	30.00	-3.96	101	89	VERTICAL	QP
5	164.66	43.62	-19.16	24.46	30.00	-5.54	105	225	VERTICAL	QP
6	315.57	37.50	-14.98	22.52	37.00	-14.48	112	210	VERTICAL	Peak

- Negative number in the margin column indicates the amount (in dB) that the recorded emission is Below the limit.
- V means in Vertical Antenna Polarization, H means in Horizontal, and QP means in Quasi-Peak.
- Corrected Factor = Insertion loss (Antenna Factor) + Cable loss.
- Corrected Reading = Reading + Corrected Factor.
- Margin limit = Correction Reading - limit value.

4 Photographs of the Tests

4.1 Conducted Disturbance Emission Test



Front View



Rear View

4.2 Radiated Disturbances Emission Test



Front View

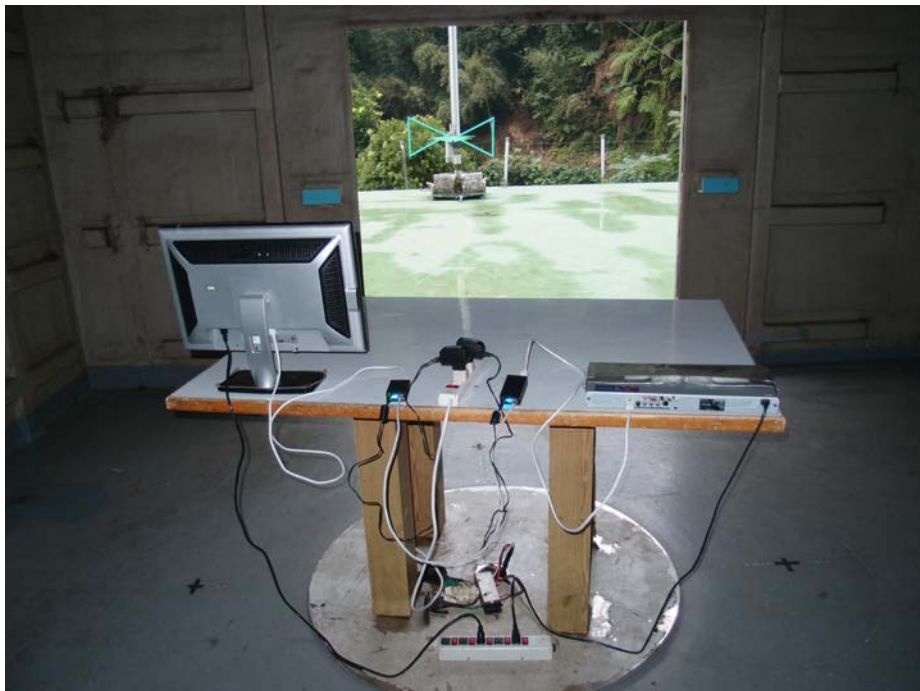

Rear View

5 Photographs of the EUT

5.1 RX



Front View of the EUT



Rear View of the EUT



Inside View of the EUT



Front View of the PCB



View of the Cable 1



View of the Cable 2

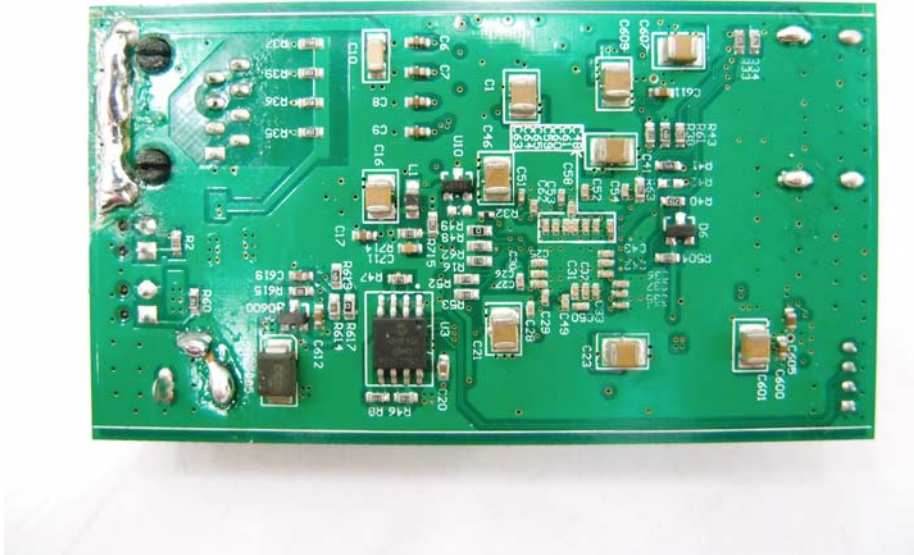

Rear View of the PCB



View of the Adapter Power



View of the Cable 1



View of the Cable 2