



VERIFICATION OF COMPLIANCE

This Verification of Compliance is hereby issued to the below named company. The test results of this report relate only to the tested sample identified in this report.

**Technical Standard: EMC DIRECTIVE 2004/108/EC
(EN 55022 / EN 55024)**

General Information

Applicant: SMART HOME ENGINEERING CORP.
10F. No. 493, Chung-Cheng Rd., Hsin Tien City,
Taipei 231, Taiwan (R.O.C.)

Product Description

EUT Description: Extended Long Range HDMI to DVI + Audio Converter
Model Number: HE01SXXX
(Where X = any alpha character "a"- "z", "A" - "Z", or numeric character "0"- "9", or combination of alpha and numeric characters. That is used for market reason.)

Measurement Standard

EN 55022:2006
EN 61000-3-2:2000 + A2:2005
EN 61000-3-3:1995 + A1:2001 + A2:2005
EN 55024:1998 + A1:2001 + A2:2003
IEC 61000-4-2:1995 + A1:1998 + A2:2000 ; IEC 61000-4-3:2002 + A1:2002 ;
IEC 61000-4-4:2004 ; IEC 61000-4-5:1995 + A1:2000 ; IEC 61000-4-6:1996 + A1:2000 ;
IEC 61000-4-8:1993 + A1:2000 ; IEC 61000-4-11:2004

Measurement Facilities

Laboratory Name: **Compliance Certification Services Inc. (Hsin-Chu Lab).**
*Rm. 258, Bldg. 17, NO.195, Sec.4 Chung Hsing Rd.,
ChuTung Chen, Hsinchu, Taiwan 310, R.O.C
Tel: +886-3-5910068 / Fax: +886-3-5825720*

This device has been shown to be in compliance with and was tested in accordance with the measurement procedures specified in the Standards & Specifications listed above and as indicated in the measurement report number: 80328303-E

Jason Chang

Jason Chang / Team Leader



Date: April 03, 2008



EC-Declaration of Conformity

For the following equipment:

Extended Long Range HDMI to DVI + Audio Converter

(Product Name)

HE01SXXX

(Where X = any alpha character "a"-“z”, “A” - “Z”, or numeric character “0”-“9”, or combination of alpha and numeric characters. That is used for market reason.)

(Model Designation / Trade Name)

SMART HOME ENGINEERING CORP.

(Company Name)

10F. No. 493, Chung-Cheng Rd., Hsin Tien City, Taipei 231, Taiwan (R.O.C.)

(Company Address)

is herewith confirmed to comply with the requirements set out in the Council Directive on the Approximation of the Laws of the Member States relating to Electromagnetic Compatibility Directive (2004/108/EC, Amended by 92/31/EEC, 2006/95/EC & 98/13/EC), For the evaluation regarding the Electromagnetic Compatibility (2004/108/EC, Amended by 92/31/EEC, 2006/95/EC & 98/13/EC), the following standards are applied:

EN 55022:2006

EN 61000-3-2:2000 + A2:2005

EN 61000-3-3:1995 + A1:2001 + A2:2005

EN 55024:1998 + A1:2001 + A2:2003

IEC 61000-4-2:1995 + A1:1998 + A2:2000 ; IEC 61000-4-3:2002 + A1:2002 ;

IEC 61000-4-4: 2004 ; IEC 61000-4-5:1995 + A1:2000 ; IEC 61000-4-6:1996 + A1:2000 ;

IEC 61000-4-8:1993 + A1:2000 ; IEC 61000-4-11:2004

The following manufacturer / importer or authorized representative established within the EUT is responsible for this declaration:

(Company Name)

(Company Address)

Person responsible for making this declaration:

(Name, Surname)

(Position / Title)

(Place)

(Date)

(Legal Signature)

CE EMC**TEST REPORT****For****Extended Long Range HDMI to DVI + Audio Converter****Model : HE01SXXX**

(Where X = any alpha character “a”-“z”, “A” - “Z”, or numeric character “0”-“9”, or combination of alpha and numeric characters. That is used for market reason.)

Issued for**SMART HOME ENGINEERING CORP.**

**10F. No. 493, Chung-Cheng Rd., Hsin Tien City,
Taipei 231, Taiwan (R.O.C.)**

Issued by**Compliance Certification Services Inc.****Hsinchu Lab.**

Rm. 258, Bldg. 17, NO.195, Sec.4 Chung Hsing Rd.,
ChuTung Chen, Hsinchu, Taiwan 310, R.O.C

TEL: (03) 591-0068**FAX: (03) 582-5720**NVLAP LAB CODE 200118-0

Note: This report shall not be reproduced except in full, without the written approval of Compliance Certification Services Inc. This document may be altered or revised by Compliance Certification Services Inc. personnel only, and shall be noted in the revision section of the document. The client should not use it to claim product endorsement by TAF, NVLAP or any government agencies. The test results in the report only apply to the tested sample.



TABLE OF CONTENTS

TITLE	PAGE NO.
1. TEST REPORT CERTIFICATION	3
2. EUT DESCRIPTION	4
2.1 DESCRIPTION OF EUT & POWER.....	4
2.2 DESCRIPTION OF TEST MODE.....	4
3. TEST METHODOLOGY	4
4. FACILITIES AND ACCREDITATION	5
4.1 FACILITIES.....	5
4.2 EQUIPMENT.....	5
4.3 LABORATORY ACCREDITATIONS LISTINGS.....	5
4.4 LABORATORY ACCREDITATIONS AND LISTINGS.....	6
5. CALIBRATION AND UNCERTAINTY	7
5.1 MEASURING INSTRUMENT CALIBRATION.....	7
5.2 MEASUREMENT UNCERTAINTY.....	7
6. SETUP OF EQUIPMENT UNDER TEST	8
7. EMISSION TEST	9
7.1 RADIATED EMISSIONS.....	9-13
7.2 POWERLINE CONDUCTED EMISSIONS.....	14-33
7.3 CURRENT HARMONIC TEST.....	34-40
7.4 VOLTAGE FLUCTUATION AND FLICKER TEST.....	41-44
8. IMMUNITY TEST	45-46
8.1 ELECTROSTATIC DISCHARGE TEST.....	47-50
8.2 RADIATED SUSCEPTIBILITY TEST.....	51-52
8.3 ELECTRICAL FAST TRANSIENT/BURST TEST.....	53
8.4 SURGE TEST.....	54
8.5 CONDUCTED SUSCEPTIBILITY TEST.....	55
8.6 POWER FREQUENCY MAGNETIC FIELD IMMUNITY TEST.....	56
8.7 VOLTAGE DIP AND INTERRUPTION TEST.....	57
APPENDIX SETUP PHOTOS	58-69

1. TEST REPORT CERTIFICATION

Applicant : SMART HOME ENGINEERING CORP.
Address : 10F. No. 493, Chung-Cheng Rd., Hsin Tien City,
Taipei 231, Taiwan (R.O.C.)
Equipment Under Test : Extended Long Range HDMI to DVI + Audio Converter
Model : HE01SXXX
(Where X = any alpha character "a"- "z", "A" - "Z", or numeric
character "0"- "9", or combination of alpha and numeric characters.
That is used for market reason.)
Tested Date : December 13 ~ 26, 2007

APPLICABLE STANDARD	
Emission Standard	Test Result
EN 55022:2006	No non-compliance noted
EN 61000-3-2:2000 + A2:2005	No non-compliance noted
EN 61000-3-3:1995 + A1:2001 + A2:2005	No non-compliance noted
Immunity Standard EN 55024:1998 + A1:2001 + A2:2003	Test Result
IEC 61000-4-2:1995 + A1:1998 + A2:2000	No non-compliance noted
IEC 61000-4-3:2002 + A1:2002	No non-compliance noted
IEC 61000-4-4:2004	No non-compliance noted
IEC 61000-4-5:1995 + A1:2000	No non-compliance noted
IEC 61000-4-6:1996 + A1:2000	No non-compliance noted
IEC 61000-4-8:1993 + A1:2000	No non-compliance noted
IEC 61000-4-11:2004	No non-compliance noted

Approved by:

Jason Chang

Jason Chang
Team Leader of Hsinchu Laboratory
Compliance Certification Services Inc.

Reviewed by:



Alan Fan
Alan Fan
Team Leader of Hsinchu Laboratory
Compliance Certification Services Inc.

WE HEREBY CERTIFY THAT: The measurements shown in the attachment were made in accordance with the procedures indicated, and the energy emitted by the equipment was found to be within the limits applicable. We assume full responsibility for the accuracy and completeness of these measurements and vouch for the qualifications of all persons taking them.

2. EUT DESCRIPTION

2.1 DESCRIPTION OF EUT & POWER

Product Name	Extended Long Range HDMI to DVI + Audio Converter
Model Number	HE01SXXX (Where X = any alpha character “a”-“z”, “A” - “Z”, or numeric character “0”-“9”, or combination of alpha and numeric characters. That is used for market reason.)
Power Source	5VDC (FORM POWER ADAPTER)
Test Voltage	230VAC / 50Hz
I/O Port	EUT1 : DVI PORT × 1, AUDIO PORT × 1, VIDEO PORT × 1 EUT2 : RJ45 PORT × 1, HDMI PORT × 1 EUT3 : RJ45 PORT × 1, HDMI PORT × 1

Power Adapter :

No.	Manufacturer	Model No.	Power Input	Power Output
1	CD COMING DATA	CP0520	100~240V~50 ; 60Hz 0.5A	+5V, 2A
2	CD COMING DATA	CP0520	100~240V~50 ; 60Hz 0.5A	+5V, 2A
3	CD COMING DATA	CP0520	100~240V~50 ; 60Hz 0.5A	+5V, 2A

Remark :

1. For more details, please refer to the User's manual of the EUT.

2.2 DESCRIPTION OF TEST MODE

1	800dpi × 600dpi mode
2	1024dpi × 768dpi mode
3	1600dpi × 1200dpi mode

The test modes are customer's demand.

3. TEST METHODOLOGY

The tests documented in this report were performed in accordance with EN 55022:2006, EN 61000-3-2:2000 + A2:2005, EN 61000-3-3:1995 + A1:2001 + A2:2005, EN 55024:1998 + A1:2001 + A2:2003.



4. FACILITIES AND ACCREDITATION

4.1 FACILITIES

All measurement facilities used to collect the measurement data are located at Rm.258, Bldg.17, NO.195 , Sec. 4, Chung Hsing Rd., Chu-Tung Chen. Hsin-Chu, Taiwan 310 R.O.C.

The sites are constructed in conformance with the requirements of ANSI C63.7, ANSI C63.4 and CISPR Publication 22.

4.2 EQUIPMENT

Radiated emissions are measured with one or more of the following types of linearly polarized antennas: tuned dipole, biconical, log periodic, bi-log, and/or ridged waveguide, horn. Spectrum analyzers with preselectors and quasi-peak detectors are used to perform radiated measurements.

Conducted emissions are measured with Line Impedance Stabilization Networks and EMI Test Receivers.





Calibrated wideband preamplifiers, coaxial cables, and coaxial attenuators are also used for making measurements.

All receiving equipment conforms to CISPR Publication 16-1, "Radio Interference Measuring Apparatus and Measurement Methods."

4.3 LABORATORY ACCREDITATIONS LISTINGS

The test facilities used to perform radiated and conducted emissions tests are accredited by National Voluntary Laboratory Accreditation Program for the specific scope of accreditation under Lab Code: 200118-0 to perform Electromagnetic Interference tests according to FCC PART 15 AND CISPR 22 requirements. No part of this report may be used to claim or imply product endorsement by NVLAP or any agency of the US Government. In addition, the test facilities are listed with Federal Communications Commission (registration no: 90585 and 90584).

4.4 LABORATORY ACCREDITATIONS AND LISTINGS

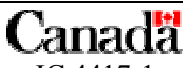
Country	Agency	Scope of Accreditation	Logo
USA	NVLAP	EN 55014-1, AS/NZS 1044, CNS 13783-1, IEC/CISPR 14-1, IEC/CISPR 22, EN 55022, EN 61000-3-2, EN 61000-3-3, ANSI C63.4, AS/NZS CISPR 22, AS/NZS 3548, IEC 61000-4-2/3/4/5/6/8/11	 200118-0
USA	FCC	3/10 meter Open Area Test Sites to perform FCC Part 15/18 measurements	 90585, 90584
Japan	VCCI	3/10 meter Open Area Test Sites to perform conducted/radiated measurements	 R-1229/1189 C-1250/1294
Taiwan	TAF	FCC Method-47 CFR Part 15 Subpart C,D,E CISPR 11, FCC METHOD-47 CFR Part 18, EN 55011, CNS 13803, CISPR 13, CNS 13439, FCC Method-47 CFR Part 15 Subpart B, CISPR 14-1, EN 55014-1, CNS 13783-1, EN 55015, CNS 14115, CISPR 22, EN 55022, VCCI CNS 13438, EN 61000-4-2/3/4/5/6/8/11	 Testing Laboratory 0240
Taiwan	BSMI	CNS 13803, CNS 13438, CNS 13439, CNS 13783-1, CNS 14115	 SL2-IS-E-0002 SL2-IN-E-0002 SL2-A1-E-0002 SL2-R1-E-0002 SL2-R2-E-0002 SL2-L1-E-0002
Canada	Industry Canada	RSS-GEN Issue 2	 IC 4417-1

* No part of this report may be used to claim or imply product endorsement by NVLAP or any agency of the US Government.



5. CALIBRATION AND UNCERTAINTY

5.1 MEASURING INSTRUMENT CALIBRATION

The measuring equipment utilized to perform the tests documented in this report has been calibrated in accordance with the manufacturer's recommendations, and is traceable to recognized national standards.

5.2 MEASUREMENT UNCERTAINTY

Where relevant, the following measurement uncertainty levels have been estimated for tests performed on the apparatus:

PARAMETER	UNCERTAINTY
Radiated Emission, 30 to 1000 MHz	+/- 3.2 dB
Radiated Emission, 1 to 26.5 GHz	+/- 3.2 dB
Power Line Conducted Emission	+/- 2.1 dB

Uncertainty figures are valid to a confidence level of 95%



6. SETUP OF EQUIPMENT UNDER TEST

SUPPORT EQUIPMENT

No.	Product	Manufacturer	Model No.	Serial No.	FCC ID
1	PC	HP	hp Compaq d330 uT	SGH410083D	DoC
2	Monitor	DELL	2407WFPB	DOC	-----
3	Mouse	HP	M-S34	LZE95050431	DZL211029
4	Keyboard	Genuine	K288	206628621	FKD48AK288
5	Printer	HP	C6431D	CN19T6S011	DoC
6	Modem	ZYXEL	Omni 56K	S1Z4107729	1880MN156K
7	Extended Long Range HDMI to DVI + Audio Converter	-----	HE01SXXX	-----	-----

No.	Signal cable description
1	DVI TO HDMI CABLE × 1, Shielded cable 1.8m with a ferrite core
2	DVI TO DVI CABLE × 1, Shielded cable 1.8m with two ferrite cores
3	RJ45 CABLE × 1, Shielded cable 20m with two ferrite cores

SETUP PIAGRAM FOR TESTS

EUT & peripherals setup diagram is shown in appendix setup photos.

EUT OPERATING CONDITION

1. PC Connect EUT1 to DVI port.
2. EUT1 Connect EUT2 to HDMI port.
3. EUT2 Connect EUT3 to RJ45 port.
4. EUT3 Connect Monitor to DVI port.
5. Start test.



7. EMISSION TEST

7.1 RADIATED EMISSIONS

LIMITS

All emanation from a class A computing device or system , including any network of conductors and apparatus connected thereto, shall not exceed the level of field strengths specified below :

Frequency (MHz)	Distance (METERS)	Field Strengths(dB μ V/m)	
		CLASS A	CLASS B
30 – 230	10	40	30
230 – 1000	10	47	37

Note :

- (1) The tighten limit shall apply at the edge between two frequency bands.
- (2) Distance refers to the distance in meters between the measuring instrument antenna and the closest point of any part of the device or system.

TEST EQUIPMENT

The following test equipment is utilized in making the measurements contained in this report.

Manufacturer or Type	Model No.	Serial No.	Date of Calibration	Calibration Period	Remark
SCHAFFER BILOG ANTENNA	CBL6112B	2696	April 19, 2007	1 Year	FINAL
R/S TEST RECEIVER	ESCS 30	826547/004	October 31, 2007	1 Year	FINAL
OPEN SITE	-----	No.1	May 06, 2007	1 Year	FINAL
BELDEN N TYPE COAXIAL CABLE	9913-30M	002	April 27, 2007	1 Year	FINAL

TEST SETUP

The diagram below shows the test setup which is utilized to make these measurements.

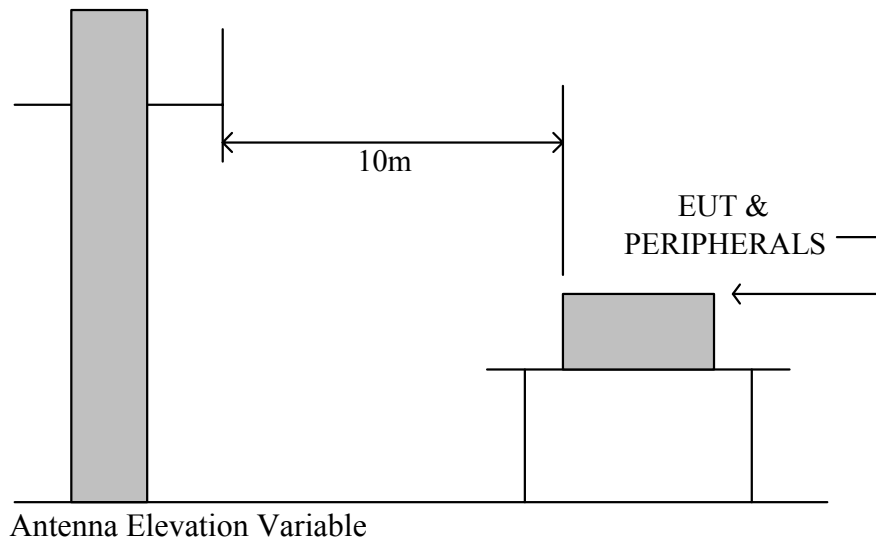

TEST PROCEDURE

The devices under test were placed on a rotatable table top 0.8 meter above ground. The table was rotated 360 degrees to determine the position of the highest radiation. EUT is set 10 meters from the interference receiving antenna which is mounted on the top of a variable height mast. The antenna height is varied between one meter and four meters above ground to find the maximum value of the field strength both horizontal polarization and vertical polarization of the antenna are set to make the measurement. The bandwidth setting on the E.M.I. meter (R/S TEST RECEIVER) is 120 KHz.

The levels are quasi peak value readings. The frequency spectrum from 30MHz to 1000MHz was investigated.

TEST RESULTS

No non-compliance noted



Product Name	Extended Long Range HDMI to DVI + Audio Converter	Test Date	2007/12/26
Model	HE01SXXX	Test By	YJ. Jeng
Test Mode	800dpi x 600dpi mode	TEMP & Humidity	25.3 , 50%

Frequency (MHz)	Antenna Factor (dB/m)	Cable Loss (dB)	Meter Reading at 10m(dBμV)		Limits (dBμV/m)	Emission Level at 10m(dBμV/m)	
			Horizontal	Vertical		Horizontal	Vertical
40.33	13.82	1.00	12.30	10.20	40.00	27.12	25.02
200.37	9.20	2.10	14.10	12.80	40.00	25.40	24.10
600.33	18.60	3.80	8.30	8.10	47.00	30.70	30.50
720.35	19.23	4.24	8.80	8.00	47.00	32.27	31.47
800.33	19.90	4.50	8.90	8.30	47.00	33.30	32.70
1000.00	21.40	5.10	7.50	7.20	47.00	34.00	33.70

Remark: Emission level (dBμV/m) = Antenna Factor (dB/m) + Cable loss (dB) + Meter Reading (dBμV).



Product Name	Extended Long Range HDMI to DVI + Audio Converter	Test Date	2007/12/26
Model	HE01SXXX	Test By	YJ. Jeng
Test Mode	1024dpi × 768dpi mode	TEMP & Humidity	25.3 , 50%

Frequency (MHz)	Antenna Factor (dB/m)	Cable Loss (dB)	Meter Reading at 10m(dBμV)		Limits (dBμV/m)	Emission Level at 10m(dBμV/m)	
			Horizontal	Vertical		Horizontal	Vertical
198.05	9.16	2.08	16.70	13.50	40.00	27.94	24.74
520.01	18.08	3.52	10.70	10.80	47.00	32.30	32.40
650.07	19.00	4.10	10.30	8.50	47.00	33.40	31.60
846.03	20.27	4.68	13.70	8.70	47.00	38.65	33.65
910.02	20.58	4.82	10.60	10.50	47.00	36.00	35.90
974.03	21.14	5.00	7.30	9.50	47.00	33.44	35.64

Remark: Emission level (dBμV/m) = Antenna Factor (dB/m) + Cable loss (dB) + Meter Reading (dBμV).



Product Name	Extended Long Range HDMI to DVI + Audio Converter	Test Date	2007/12/26
Model	HE01SXXX	Test By	YJ. Jeng
Test Mode	1600dpi × 1200dpi mode	TEMP & Humidity	25.3 , 50%

Frequency (MHz)	Antenna Factor (dB/m)	Cable Loss (dB)	Meter Reading at 10m(dBμV)		Limits (dBμV/m)	Emission Level at 10m(dBμV/m)	
			Horizontal	Vertical		Horizontal	Vertical
420.05	16.24	3.12	18.10	16.30	47.00	37.46	35.66
560.07	18.76	3.72	16.20	14.10	47.00	38.68	36.58
700.00	18.90	4.20	17.40	15.70	47.00	40.50	38.80
754.04	19.72	4.32	12.80	11.20	47.00	36.83	35.23
840.03	20.22	4.66	18.10	17.30	47.00	42.98	42.18
980.00	21.20	5.02	12.70	10.50	47.00	38.92	36.72

Remark: Emission level (dBμV/m) = Antenna Factor (dB/m) + Cable loss (dB) + Meter Reading (dBμV).



7.2 POWERLINE CONDUCTED EMISSIONS

LIMITS

Frequency (MHz)	Maximum Rf Line Voltage (dB μ V)			
	CLASS A		CLASS B	
	Q.P.	Ave.	Q.P.	Ave.
0.15 - 0.50	79	66	66-56*	56-46*
0.50 - 5.00	73	60	56	46
5.00 - 30.0	73	60	60	50

* Decreasing linearly with the logarithm of the frequency

TEST EQUIPMENT

The following test equipment is used during the conducted powerline tests :

Manufacturer or Type	Model No.	Serial No.	Date of Calibration	Calibration Period	Remark
SCHWARZBECK L.I.S.N	NSLK 8127	8127-465	July 09, 2007	1 Year	FINAL
CHASE L.I.S.N	NNLK 8129	8129118	January 26, 2007	1 Year	FINAL
R & S TEST RECEIVER	ESHS30	838550/003	January 31, 2007	1 Year	FINAL
KEENE SHIELDED ROOM	5983	No.1	N/A	N/A	FINAL
R & S PULSE LIMIT	ESH3-Z2	10117	September 17, 2007	1 Year	FINAL
BELDEN N TYPE COAXIAL CABLE	8268 M17/164	003	September 14, 2007	1 Year	FINAL

TEST SETUP

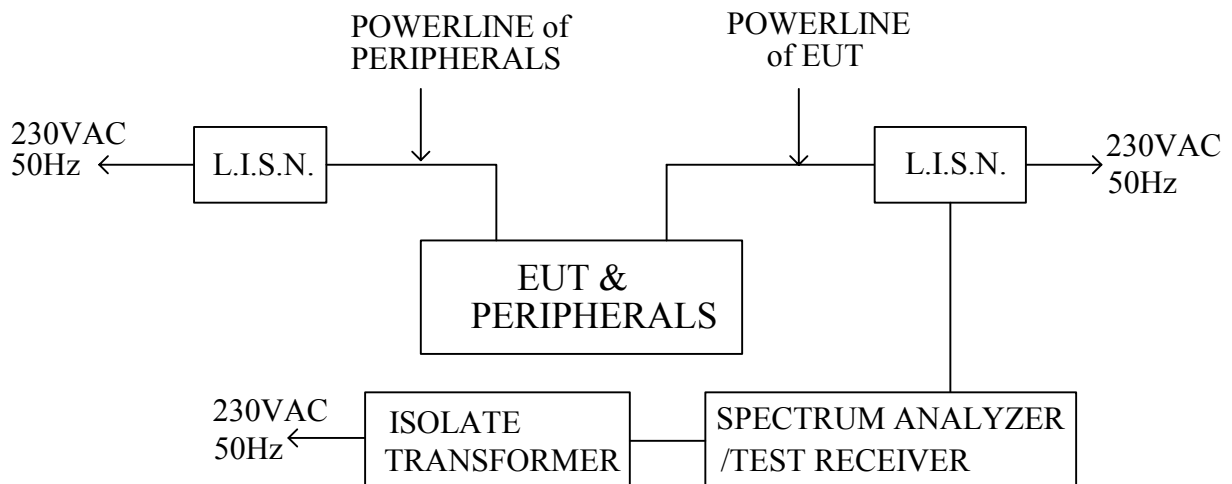

TEST PROCEDURE

The test procedure is performed in a 12ft×12ft×8ft(L×W×H) shielded room.

The EUT along with its peripherals were placed on a 1.0m(W)× 1.5m(L) and 0.8m in height wooden table and the EUT was adjusted to maintain a 0.4 meter space from a vertical reference plane. The EUT was connected to power mains through a line impedance stabilization network (LISN) which provides 50 ohm coupling impedance for measuring instrument and the chasis ground was bounded to the horizontal ground plane of shielded room. All peripherals were connected to the second LISN and the chasis ground also bounded to the horizontal ground plane of shielded room. The excess power cable between the EUT and the LISN was bundled. The power cables of peripherals were unbundled. All connecting cables of EUT and peripherals were moved to find the maximum emission.

TEST RESULTS

No non-compliance noted



Product Name	Extended Long Range HDMI to DVI + Audio Converter	Test Date	2007/12/22
Model	HE01SXXX	Test By	YJ. Jeng
Test Mode	EUT1 : 800dpi × 600dpi mode	TEMP & Humidity	26.9°C, 50%

LINE

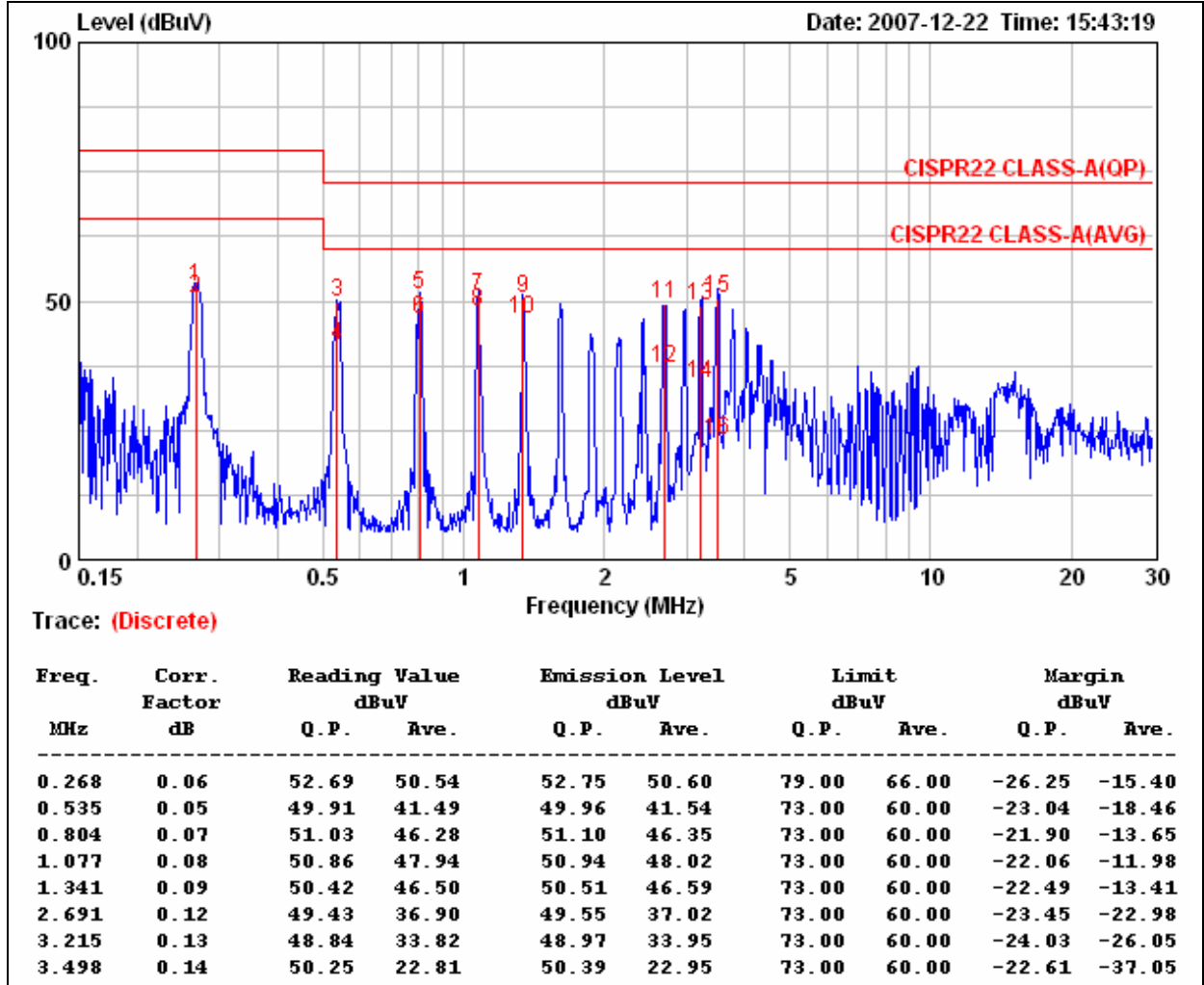

Remark:

1. Correction Factor = Insertion loss + cable loss
2. Margin value = Emission level – Limit value



Product Name	Extended Long Range HDMI to DVI + Audio Converter	Test Date	2007/12/22
Model	HE01SXXX	Test By	YJ. Jeng
Test Mode	EUT1 : 800dpi × 600dpi mode	TEMP & Humidity	26.9°C, 50%

NEUTRAL

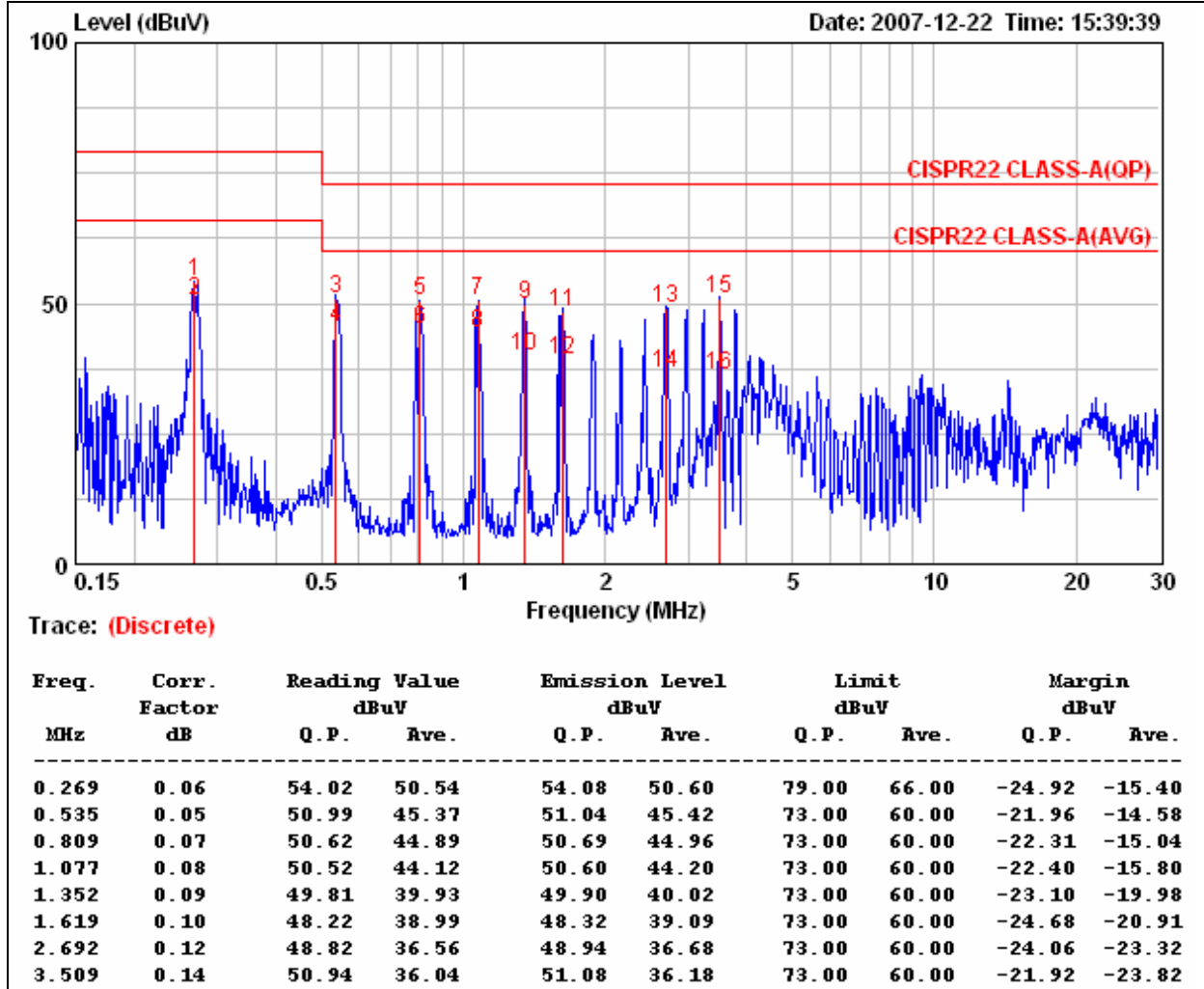
**Remark:**

1. Correction Factor = Insertion loss + cable loss
2. Margin value = Emission level – Limit value



Product Name	Extended Long Range HDMI to DVI + Audio Converter	Test Date	2007/12/22
Model	HE01SXXX	Test By	YJ. Jeng
Test Mode	EUT1 : 1024dpi × 768dpi mode	TEMP & Humidity	26.9°C, 50%

LINE

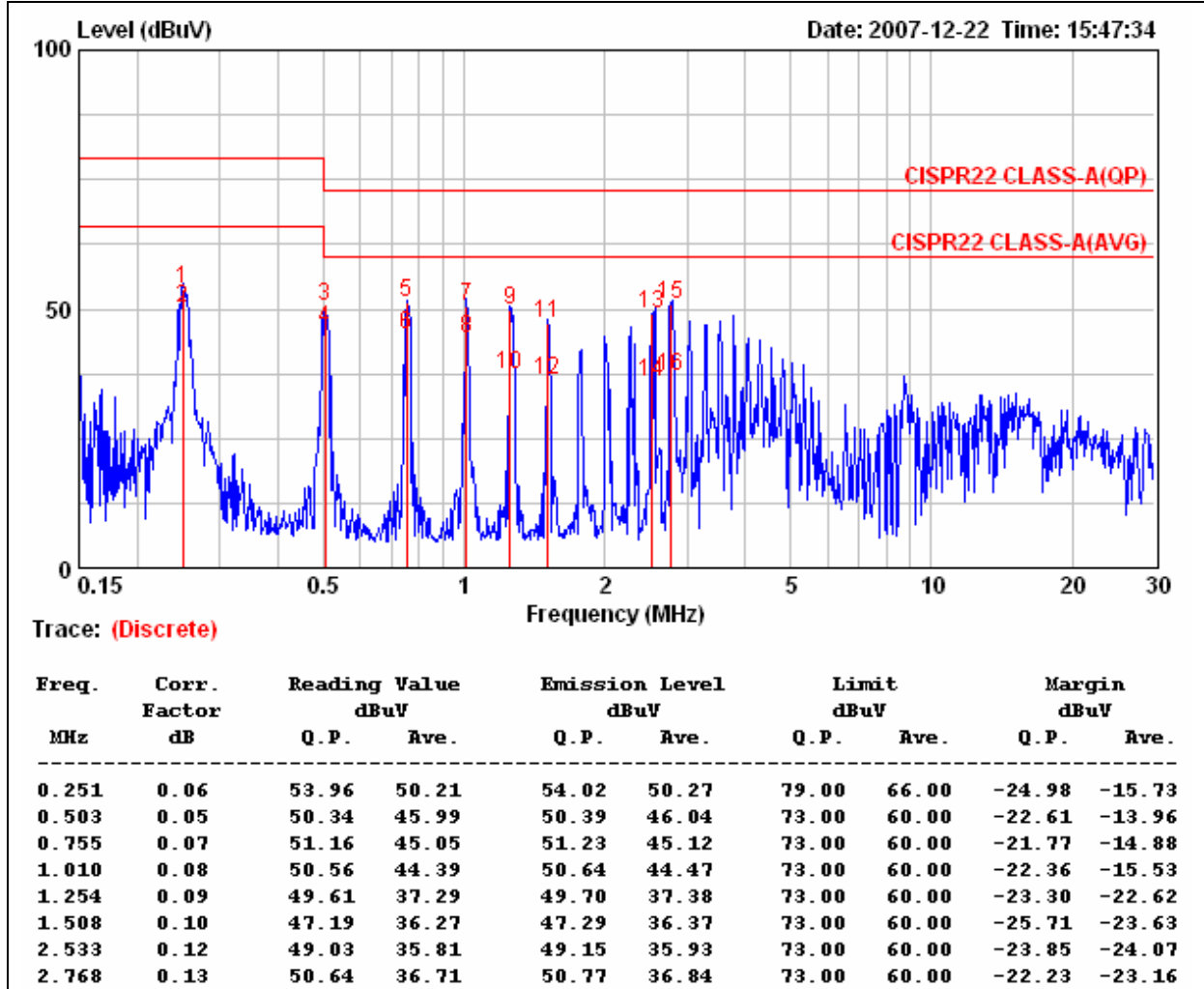
**Remark:**

1. Correction Factor = Insertion loss + cable loss
2. Margin value = Emission level – Limit value



Product Name	Extended Long Range HDMI to DVI + Audio Converter	Test Date	2007/12/22
Model	HE01SXXX	Test By	YJ. Jeng
Test Mode	EUT1 : 1024dpi × 768dpi mode	TEMP & Humidity	26.9°C, 50%

NEUTRAL

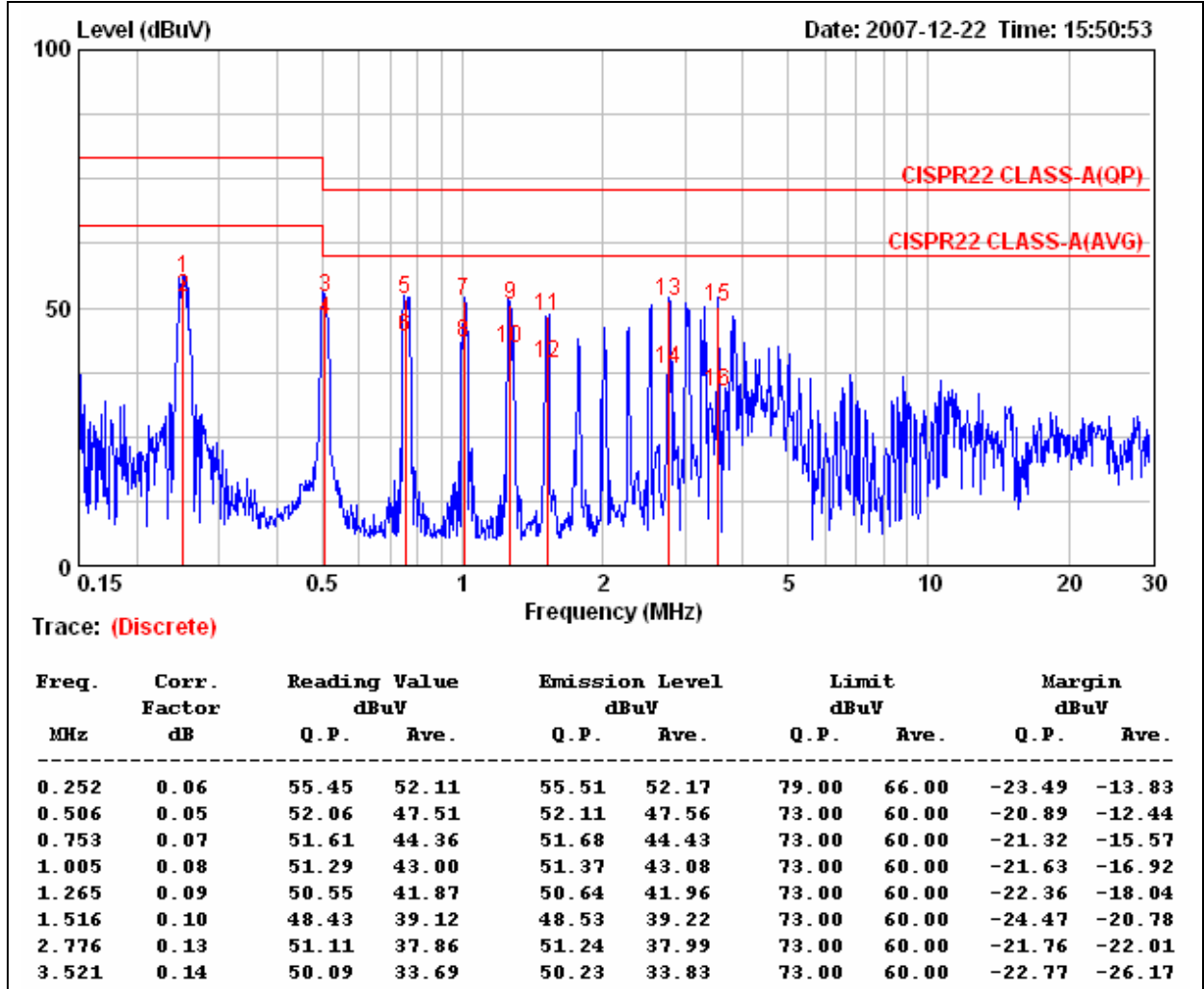

Remark:

1. Correction Factor = Insertion loss + cable loss
2. Margin value = Emission level – Limit value



Product Name	Extended Long Range HDMI to DVI + Audio Converter	Test Date	2007/12/22
Model	HE01SXXX	Test By	YJ. Jeng
Test Mode	EUT1 : 1600dpi × 1200dpi mode	TEMP & Humidity	26.9°C, 50%

LINE

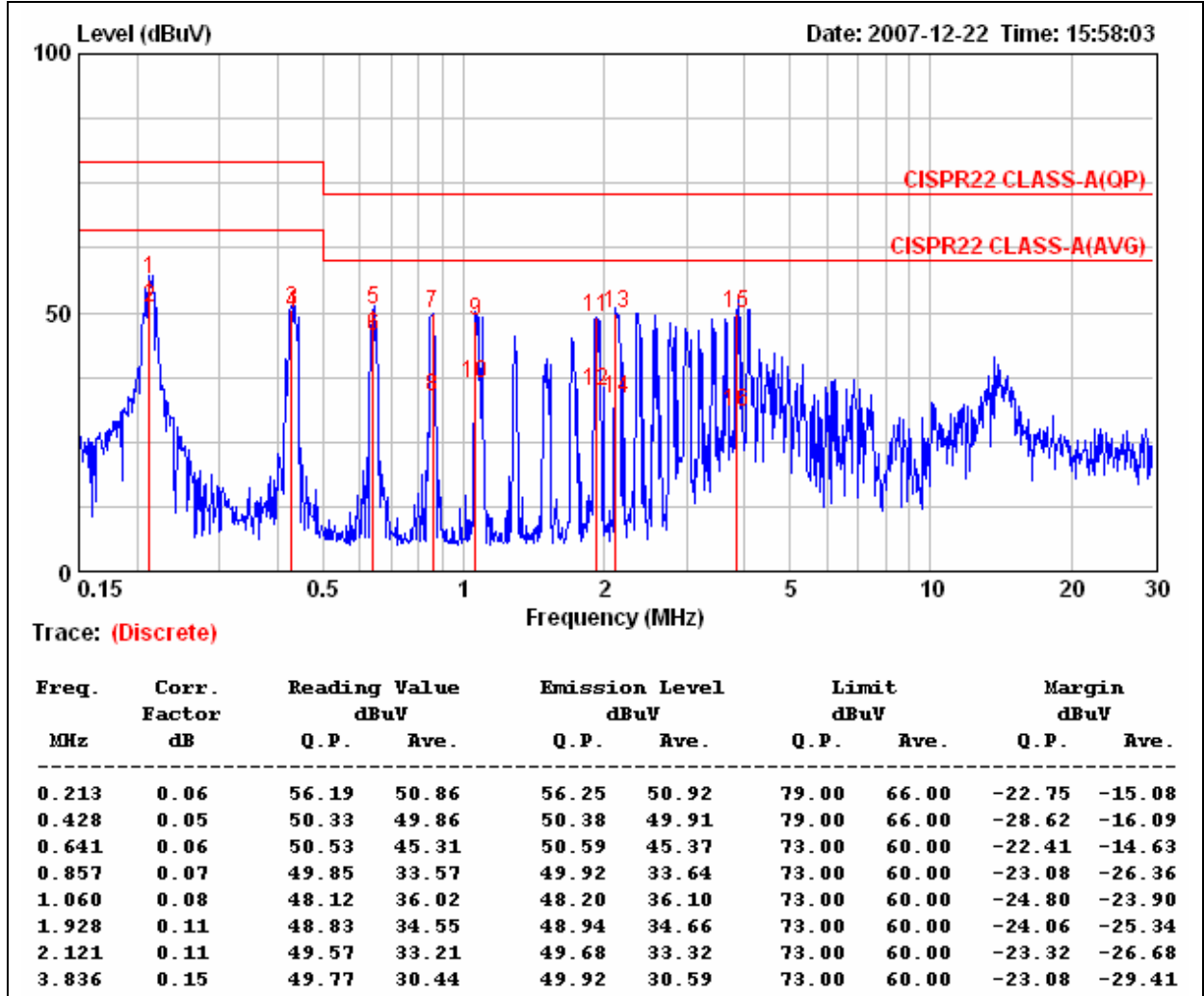

Remark:

1. Correction Factor = Insertion loss + cable loss
2. Margin value = Emission level – Limit value



Product Name	Extended Long Range HDMI to DVI + Audio Converter	Test Date	2007/12/22
Model	HE01SXXX	Test By	YJ. Jeng
Test Mode	EUT1 : 1600dpi × 1200dpi mode	TEMP & Humidity	26.9°C, 50%

NEUTRAL

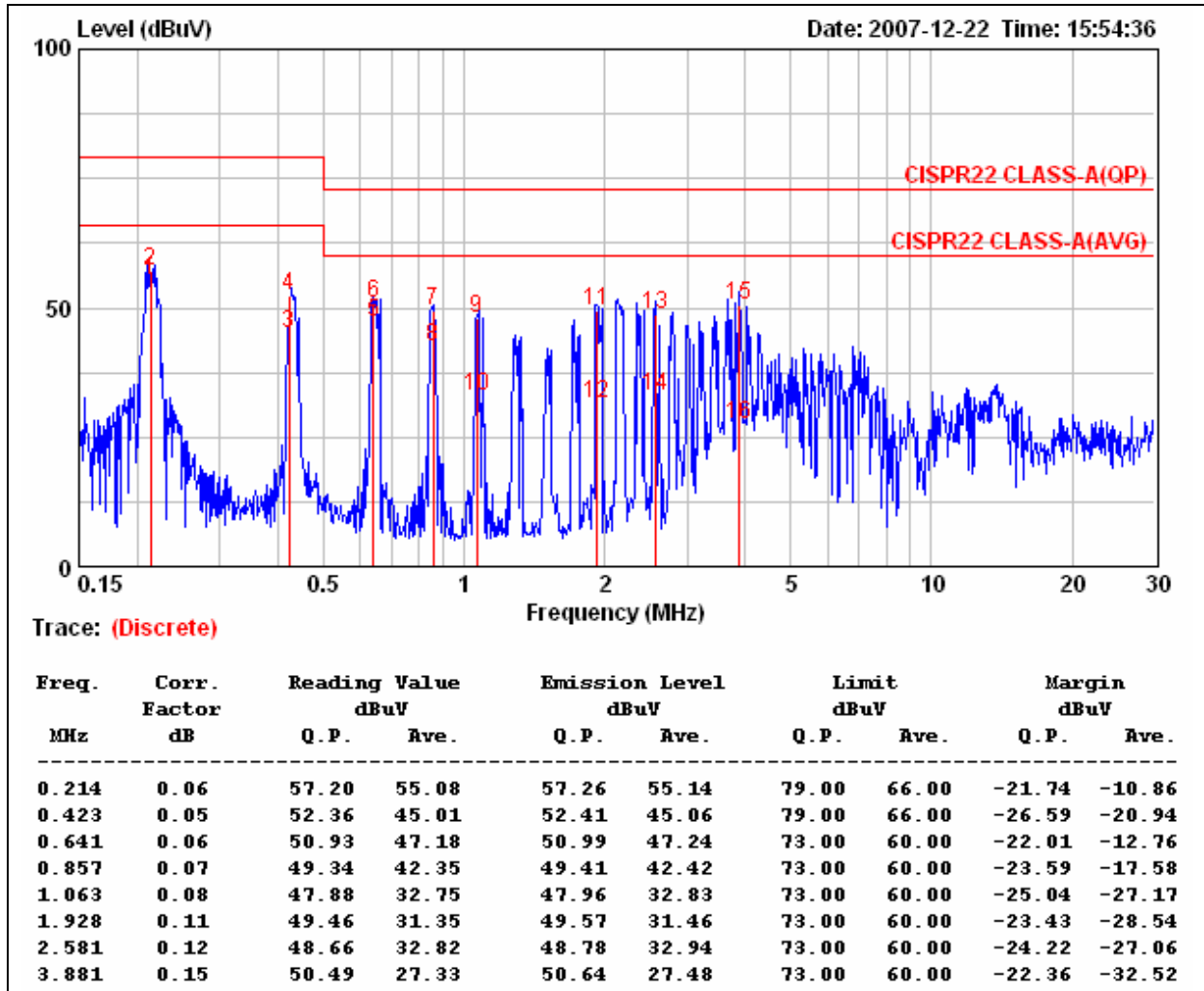
**Remark:**

1. Correction Factor = Insertion loss + cable loss
2. Margin value = Emission level – Limit value



Product Name	Extended Long Range HDMI to DVI + Audio Converter	Test Date	2007/12/22
Model	HE01SXXX	Test By	YJ. Jeng
Test Mode	EUT2 : 800dpi × 600dpi mode	TEMP & Humidity	26.9°C, 50%

LINE

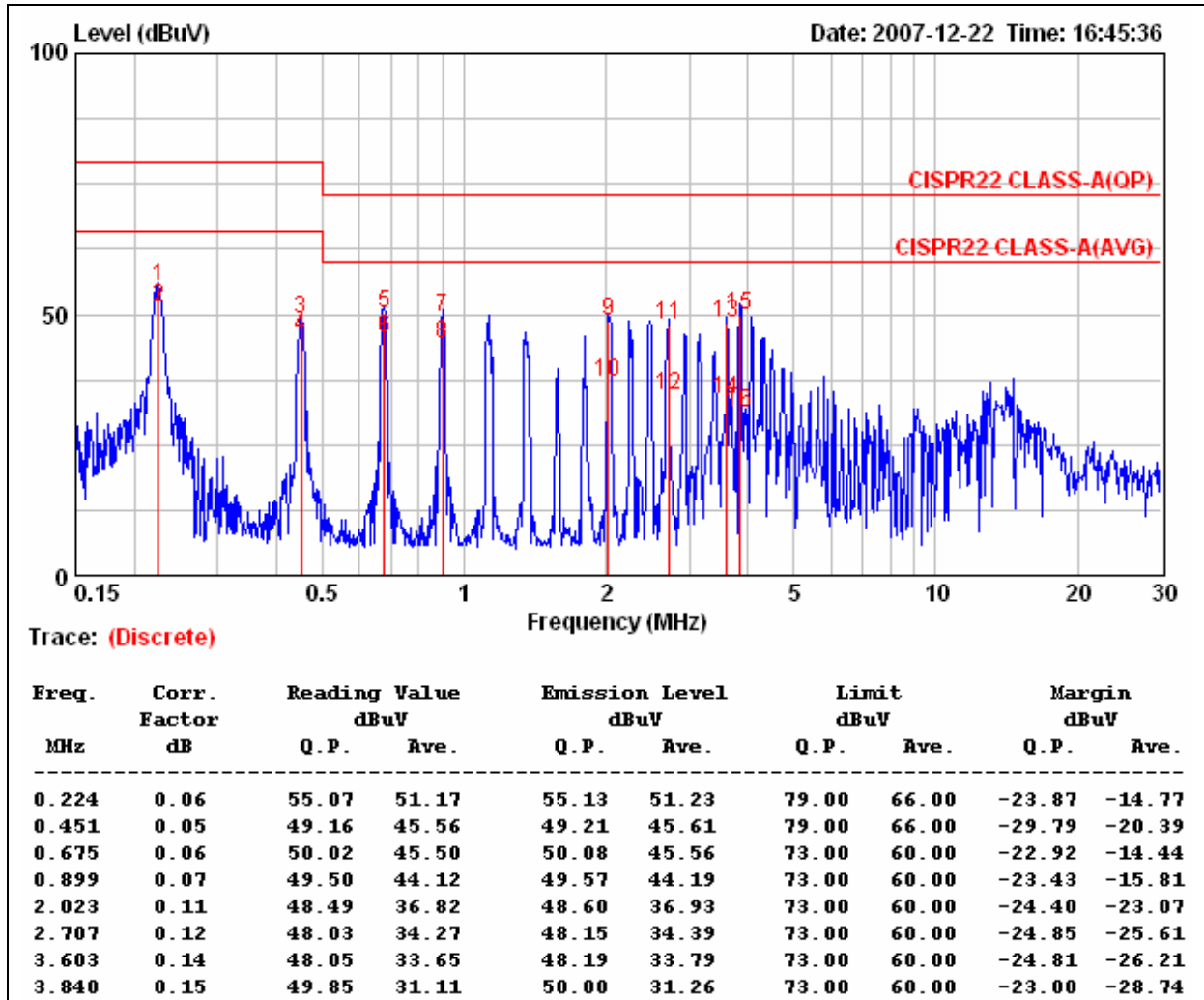
**Remark:**

1. Correction Factor = Insertion loss + cable loss
2. Margin value = Emission level - Limit value



Product Name	Extended Long Range HDMI to DVI + Audio Converter	Test Date	2007/12/22
Model	HE01SXXX	Test By	YJ. Jeng
Test Mode	EUT2 : 800dpi × 600dpi mode	TEMP & Humidity	26.9°C, 50%

NEUTRAL

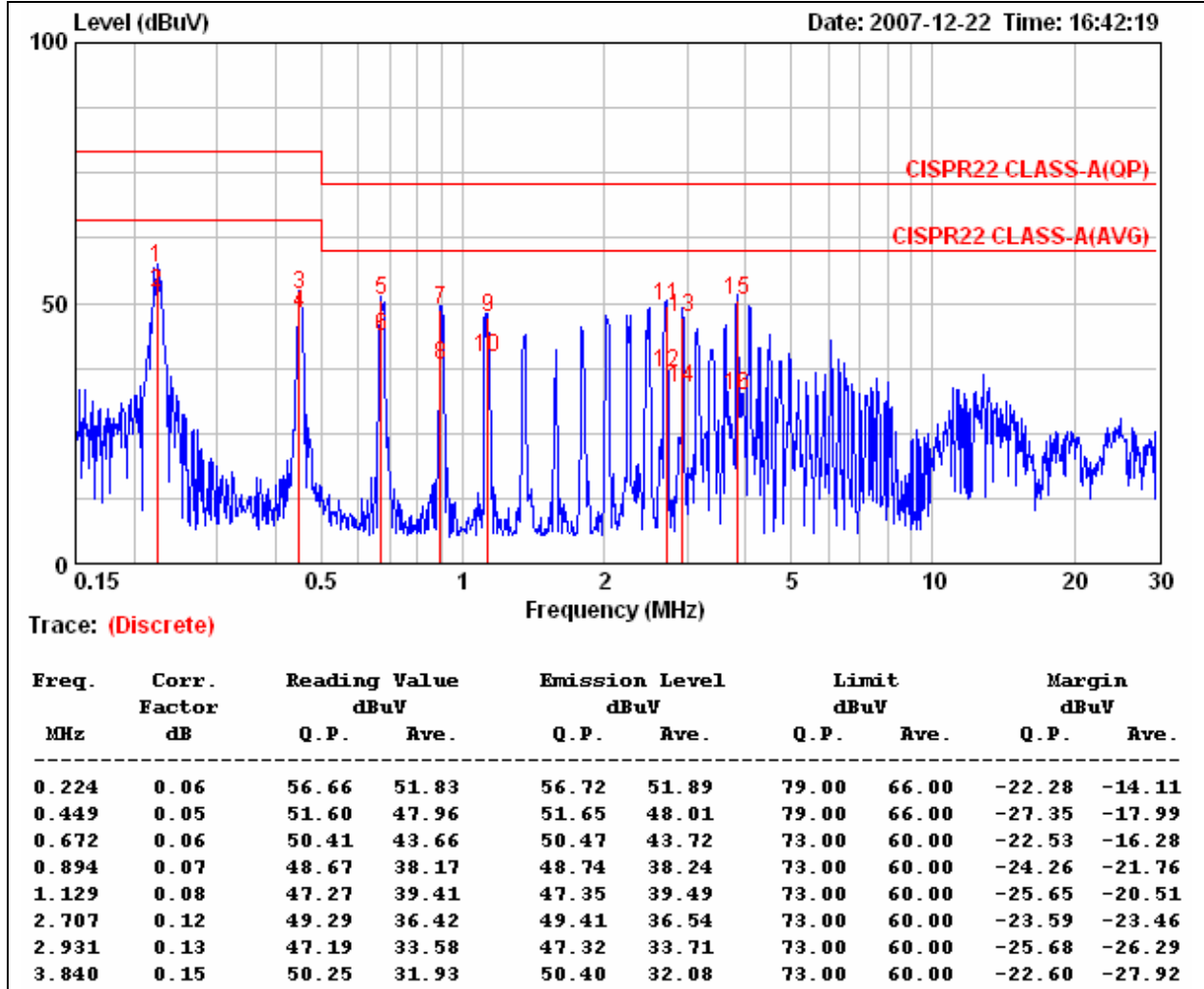
**Remark:**

1. Correction Factor = Insertion loss + cable loss
2. Margin value = Emission level – Limit value



Product Name	Extended Long Range HDMI to DVI + Audio Converter	Test Date	2007/12/22
Model	HE01SXXX	Test By	YJ. Jeng
Test Mode	EUT2 : 1024dpi × 768dpi mode	TEMP & Humidity	26.9°C, 50%

LINE

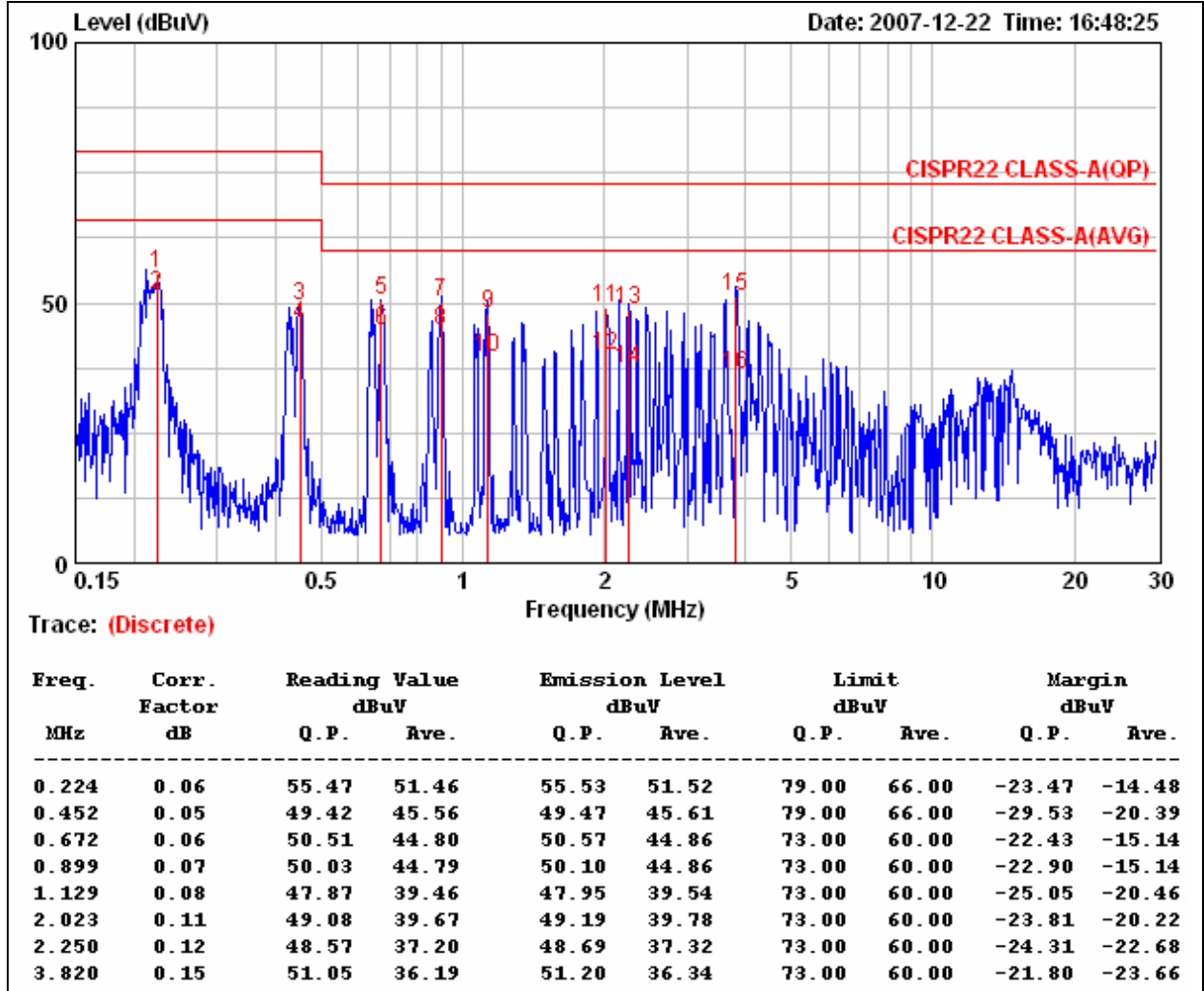

Remark:

1. Correction Factor = Insertion loss + cable loss
2. Margin value = Emission level – Limit value



Product Name	Extended Long Range HDMI to DVI + Audio Converter	Test Date	2007/12/22
Model	HE01SXXX	Test By	YJ. Jeng
Test Mode	EUT2 : 1024dpi × 768dpi mode	TEMP & Humidity	26.9°C, 50%

NEUTRAL

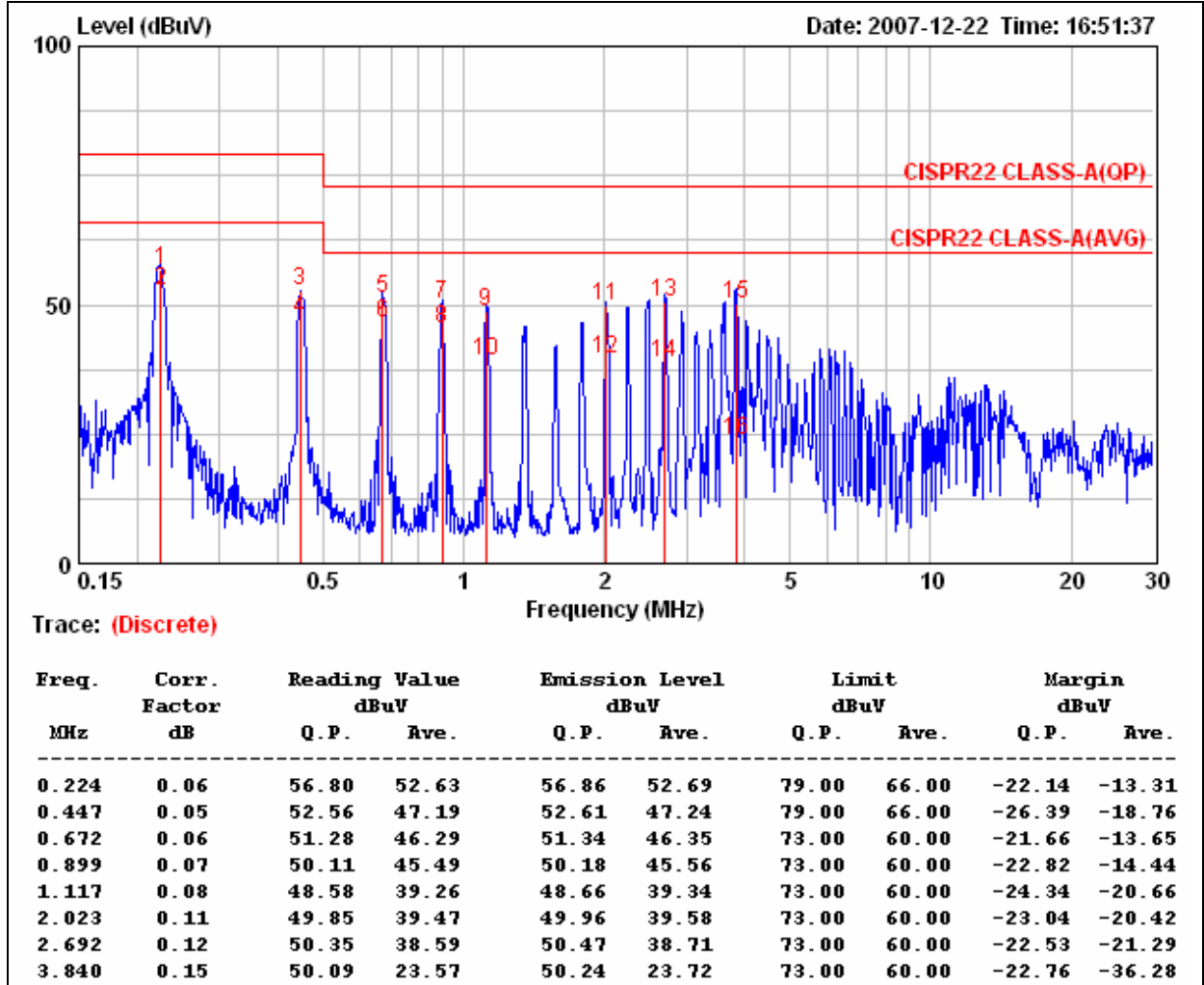

Remark:

1. Correction Factor = Insertion loss + cable loss
2. Margin value = Emission level – Limit value



Product Name	Extended Long Range HDMI to DVI + Audio Converter	Test Date	2007/12/22
Model	HE01SXXX	Test By	YJ. Jeng
Test Mode	EUT2 : 1600dpi × 1200dpi mode	TEMP & Humidity	26.9°C, 50%

LINE

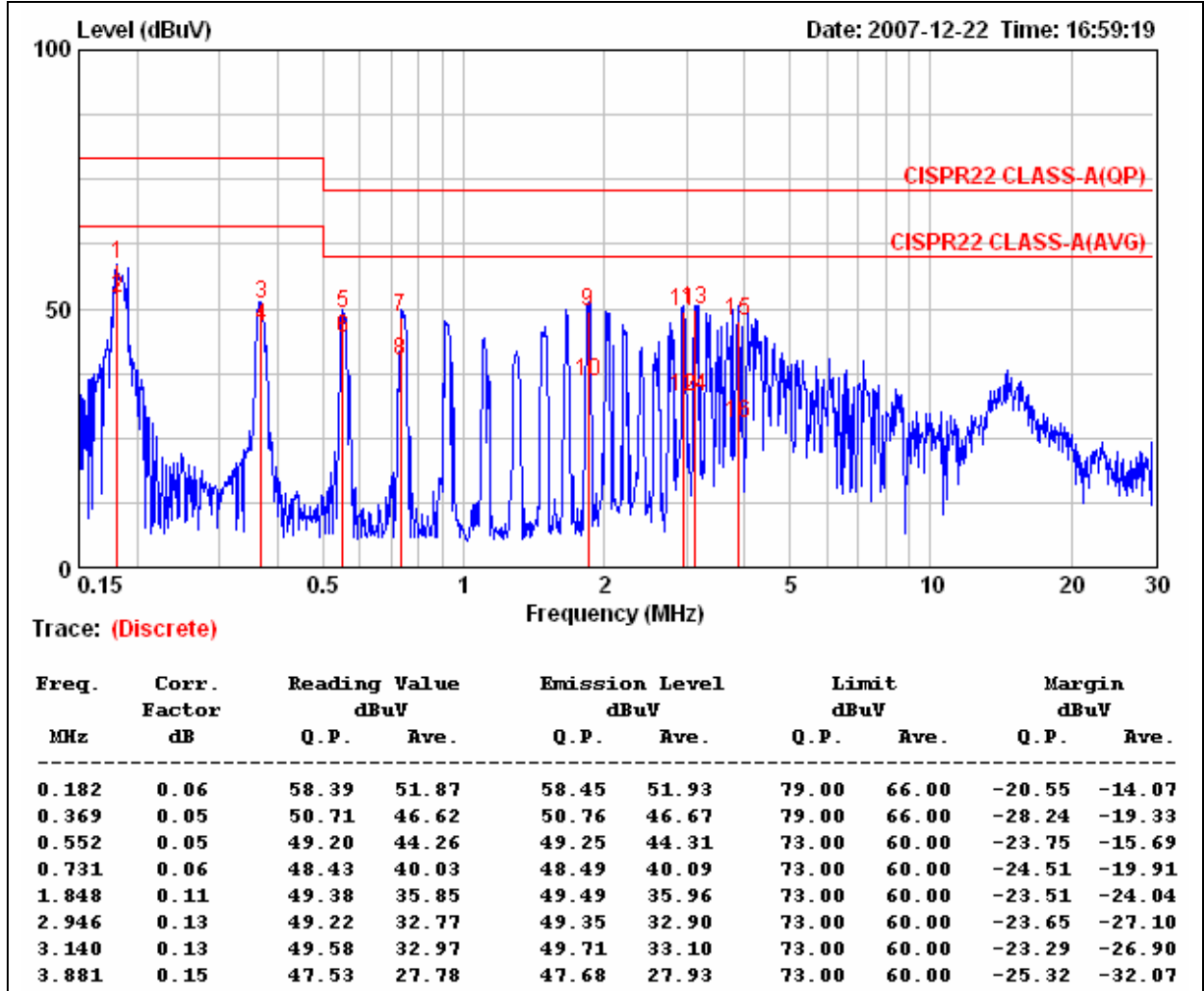

Remark:

1. Correction Factor = Insertion loss + cable loss
2. Margin value = Emission level - Limit value

Product Name	Extended Long Range HDMI to DVI + Audio Converter	Test Date	2007/12/22
Model	HE01SXXX	Test By	YJ. Jeng
Test Mode	EUT2 : 1600dpi × 1200dpi mode	TEMP & Humidity	26.9°C, 50%

NEUTRAL

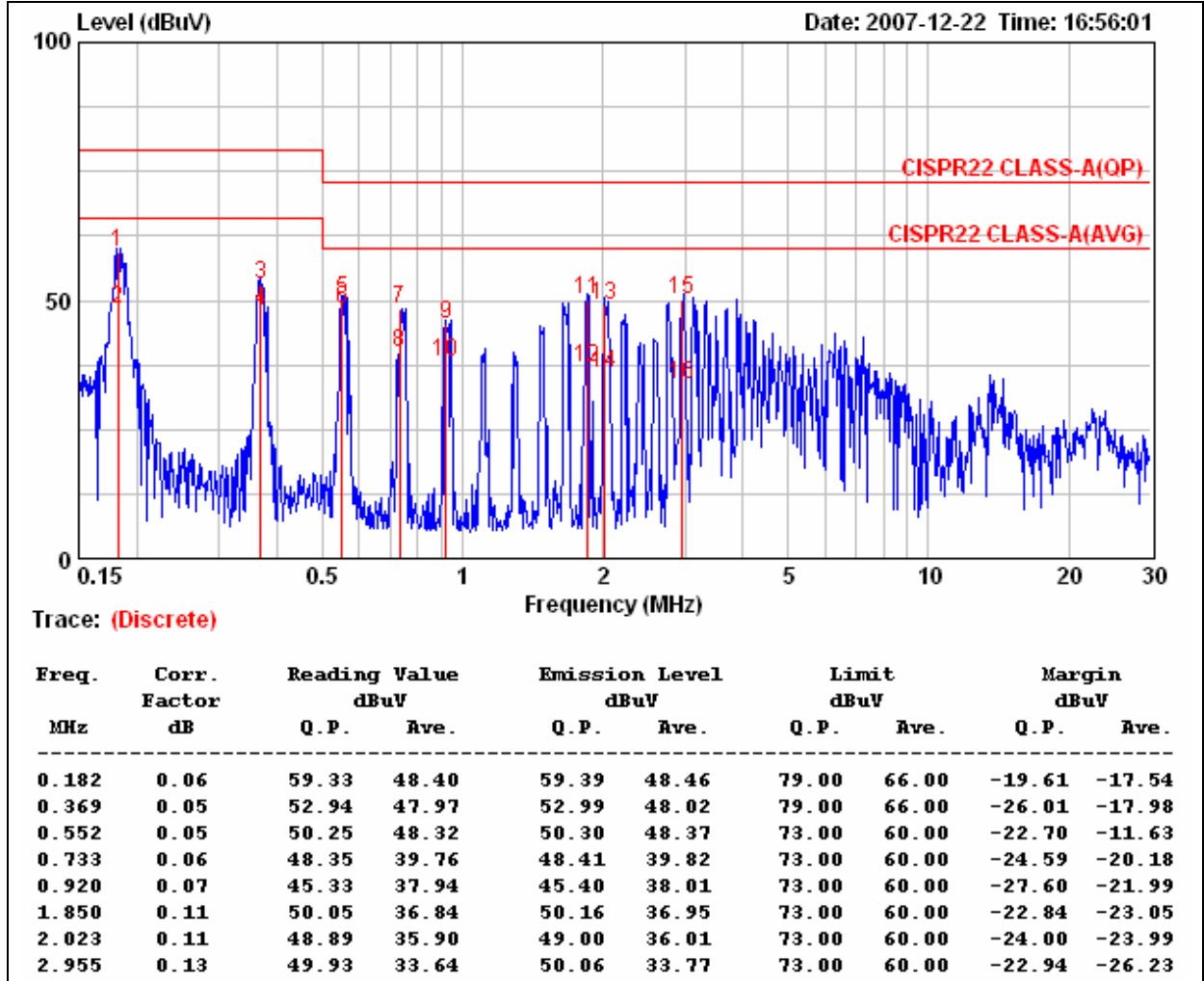

Remark:

1. Correction Factor = Insertion loss + cable loss
2. Margin value = Emission level – Limit value



Product Name	Extended Long Range HDMI to DVI + Audio Converter	Test Date	2007/12/22
Model	HE01SXXX	Test By	YJ. Jeng
Test Mode	EUT3 : 800dpi × 600dpi mode	TEMP & Humidity	26.9°C, 50%

LINE

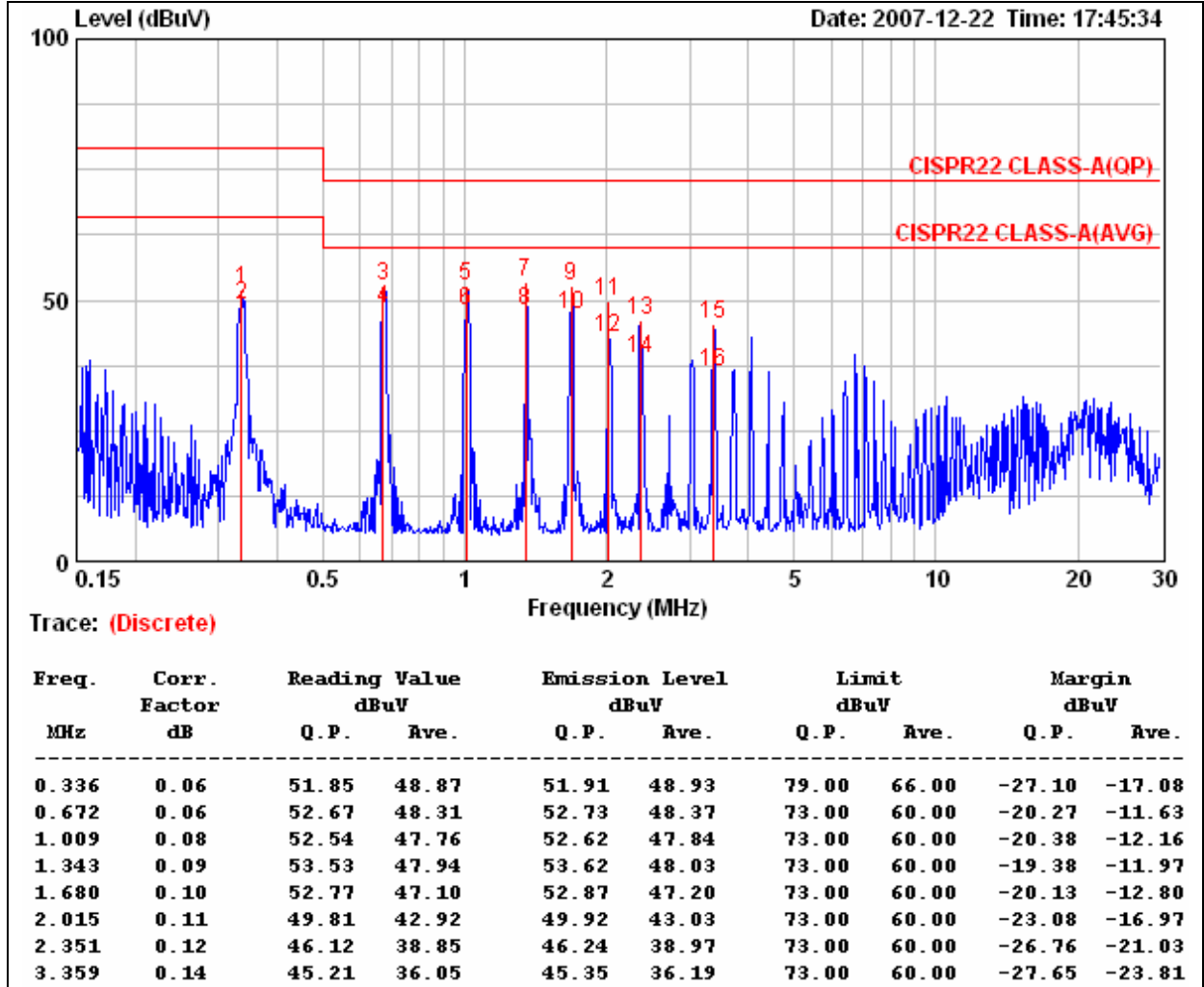

Remark:

1. Correction Factor = Insertion loss + cable loss
2. Margin value = Emission level – Limit value



Product Name	Extended Long Range HDMI to DVI + Audio Converter	Test Date	2007/12/22
Model	HE01SXXX	Test By	YJ. Jeng
Test Mode	EUT3 : 800dpi × 600dpi mode	TEMP & Humidity	26.9°C, 50%

NEUTRAL

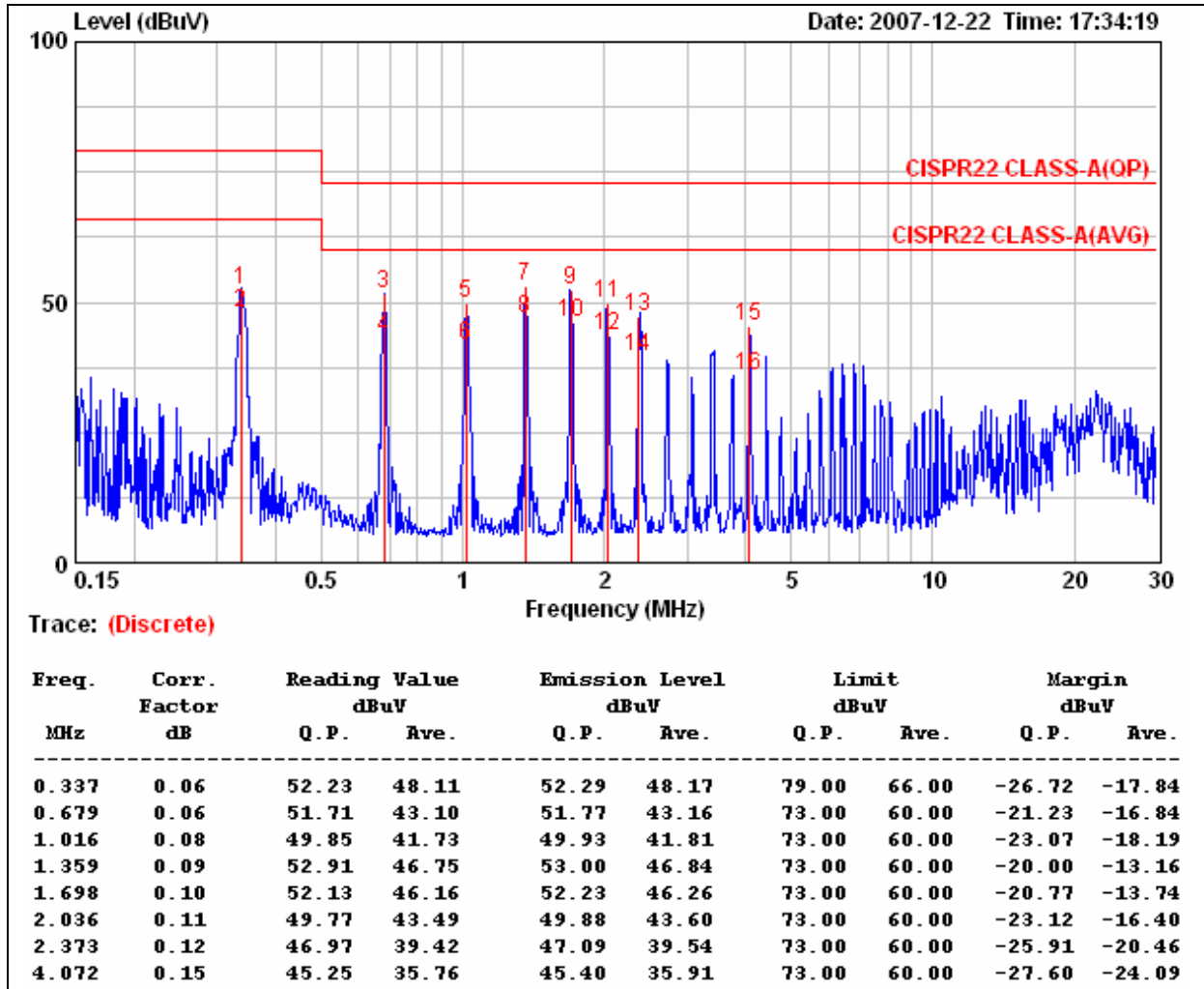
**Remark:**

1. Correction Factor = Insertion loss + cable loss
2. Margin value = Emission level – Limit value



Product Name	Extended Long Range HDMI to DVI + Audio Converter	Test Date	2007/12/22
Model	HE01SXXX	Test By	YJ. Jeng
Test Mode	EUT3 : 1024dpi × 768dpi mode	TEMP & Humidity	26.9°C, 50%

LINE

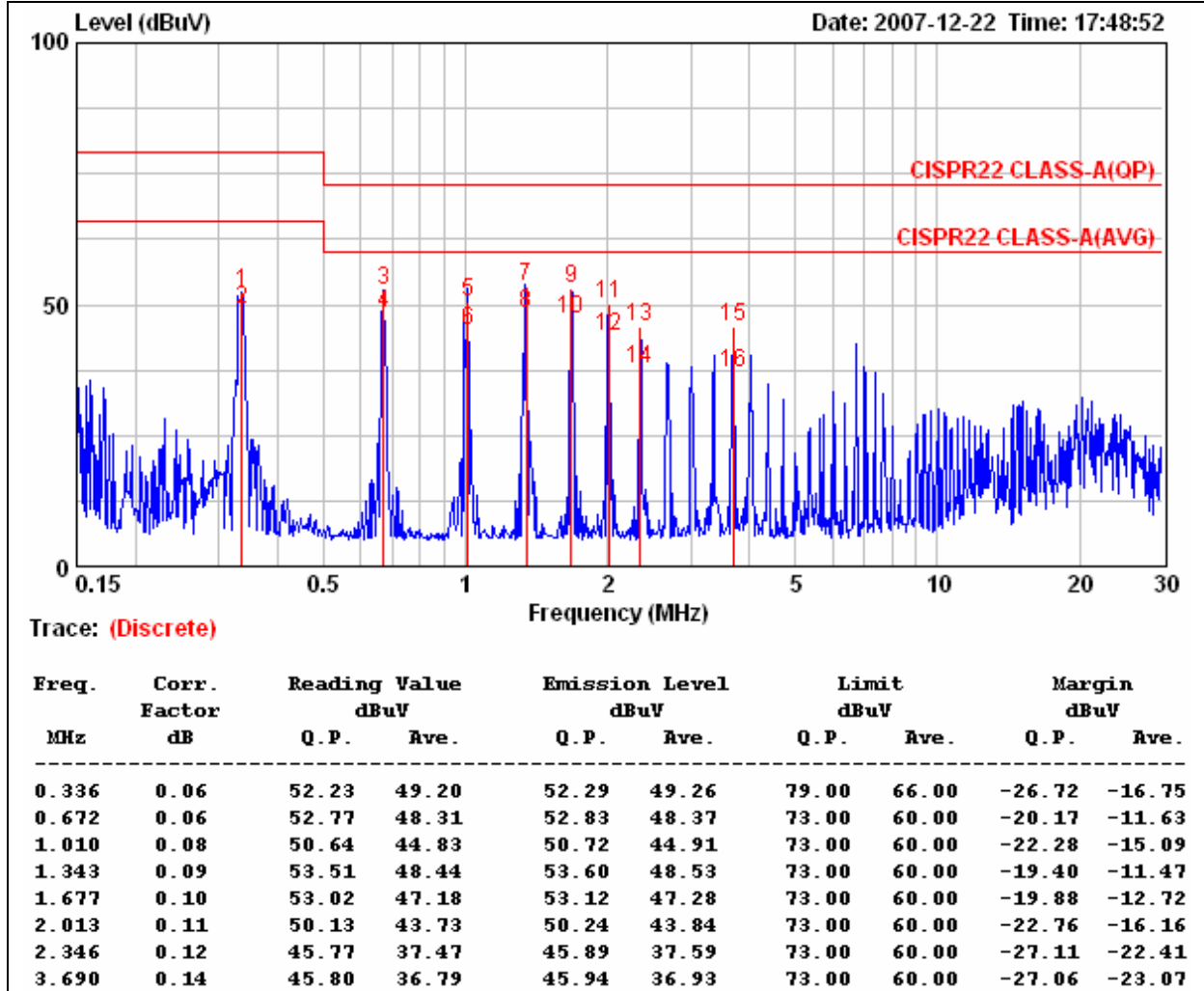
**Remark:**

1. Correction Factor = Insertion loss + cable loss
2. Margin value = Emission level – Limit value



Product Name	Extended Long Range HDMI to DVI + Audio Converter	Test Date	2007/12/22
Model	HE01SXXX	Test By	YJ. Jeng
Test Mode	EUT3 : 1024dpi × 768dpi mode	TEMP & Humidity	26.9°C, 50%

NEUTRAL

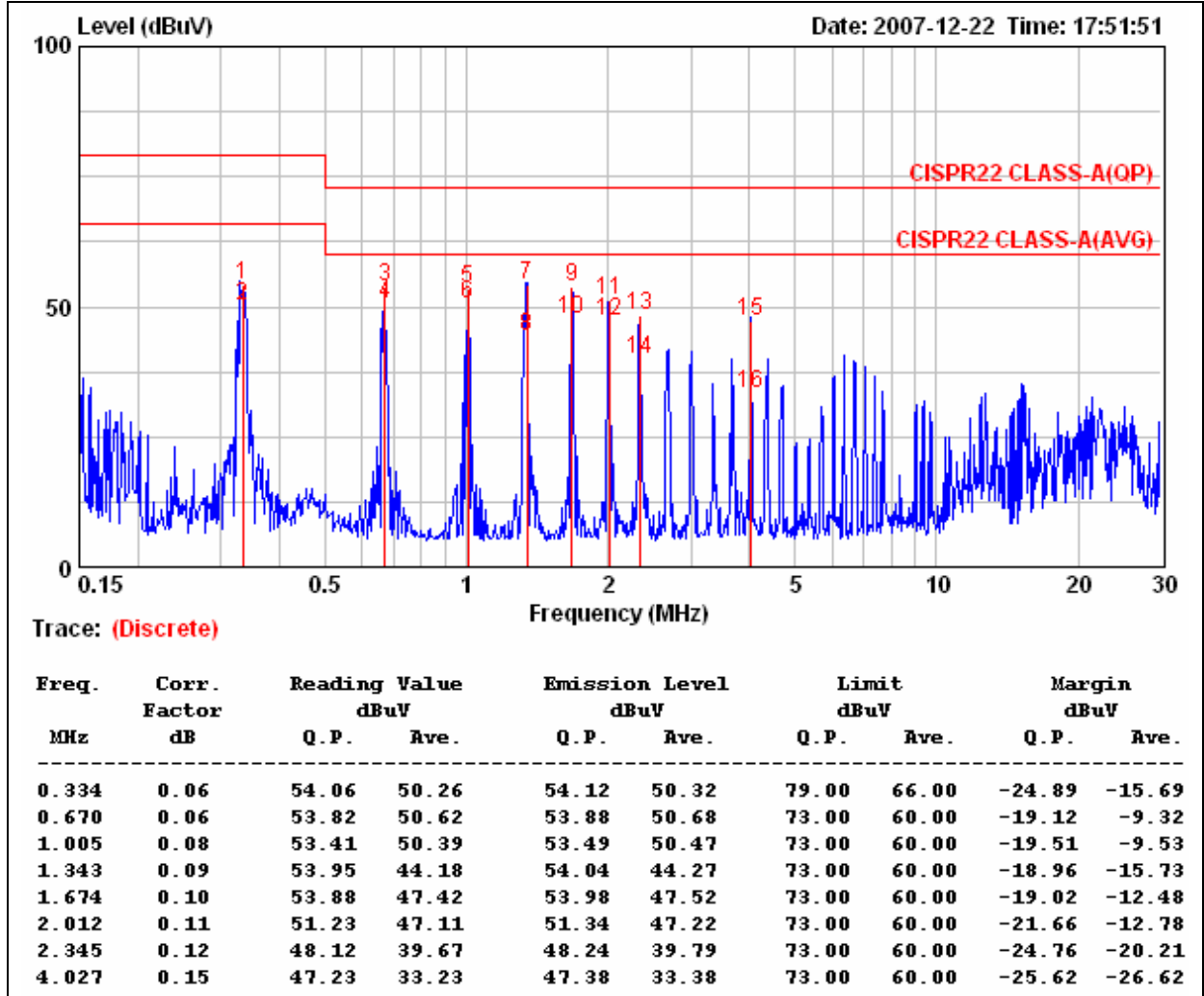

Remark:

1. Correction Factor = Insertion loss + cable loss
2. Margin value = Emission level - Limit value



Product Name	Extended Long Range HDMI to DVI + Audio Converter	Test Date	2007/12/22
Model	HE01SXXX	Test By	YJ. Jeng
Test Mode	EUT3 : 1600dpi × 1200dpi mode	TEMP & Humidity	26.9°C, 50%

LINE

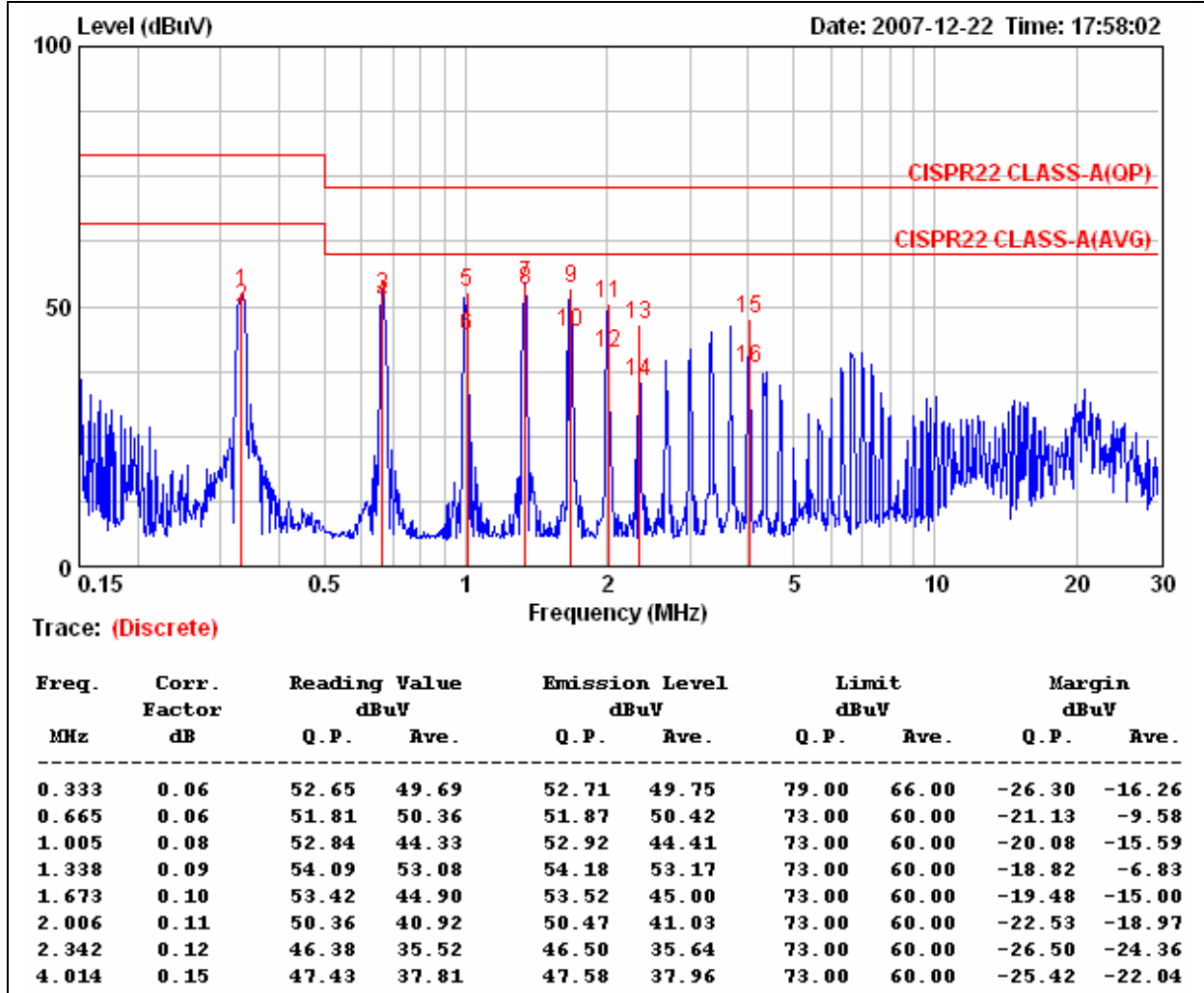
**Remark:**

1. Correction Factor = Insertion loss + cable loss
2. Margin value = Emission level – Limit value



Product Name	Extended Long Range HDMI to DVI + Audio Converter	Test Date	2007/12/22
Model	HE01SXXX	Test By	YJ. Jeng
Test Mode	EUT3 : 1600dpi × 1200dpi mode	TEMP & Humidity	26.9°C, 50%

NEUTRAL

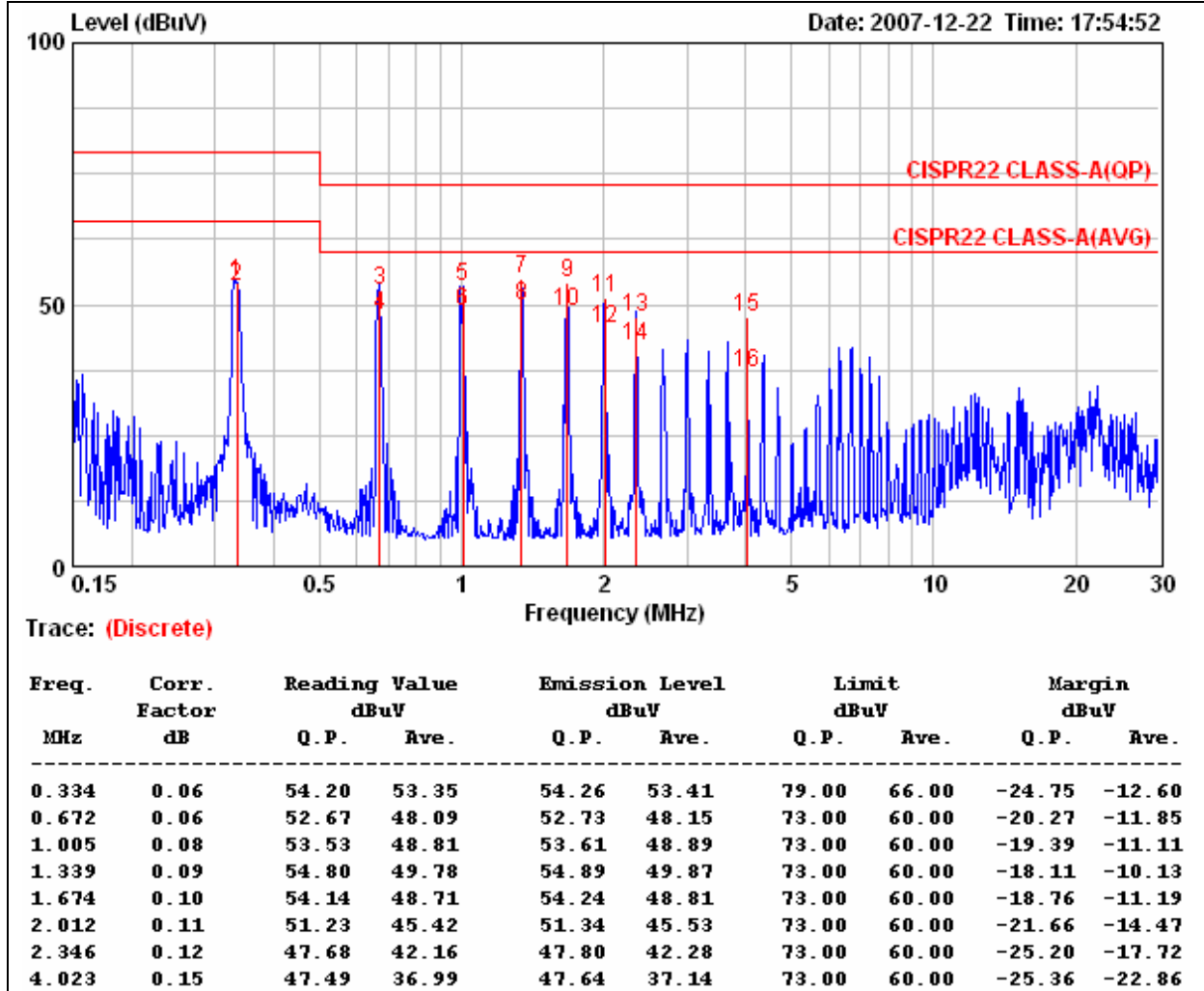
**Remark:**

1. Correction Factor = Insertion loss + cable loss
2. Margin value = Emission level – Limit value



7.3 CURRENT HARMONIC TEST

TEST EQUIPMENTS

Manufacturer or Type	Model No.	Serial No.	Date of Calibration	Calibration Period
EMC PARTNER	HARMONIC-1000	071	November 10, 2007	1 Year

TEST REQUIREMENT AND PROCEDURE

The test standard was based on EN 61000-3-2:2000 + A2:2005.

**SUMMARY OF TEST****EUT1**

Date : 2007/12/26 14:14:07 V4.16

Urms =	230.3V	Freq =	49.987	Range:	0.5 A
Irms =	0.052A	Ipk =	0.287A	cf =	5.542
P =	4.798W	S =	11.92VA	pf =	0.403
THDi =	90.5 %	THDu =	0.10 %	Class A	

Test - Time : 5min (100 %)

Test completed, Result: PASSED

Order	Freq. [Hz]	Iavg [A]	Iavg%L [%]	I _{max} [A]	I _{max} %L [%]	Limit [A]	Status
1	50	0.0225		0.0229			
2	100	0.0000	0.0000	0.0008	0.0735	1.0800	
3	150	0.0182	0.7891	0.0182	0.7895	2.3000	
4	200	0.0000	0.0000	0.0008	0.1845	0.4300	
5	250	0.0178	1.5597	0.0178	1.5607	1.1400	
6	300	0.0000	0.0000	0.0008	0.2645	0.3000	
7	350	0.0171	2.2234	0.0171	2.2234	0.7700	
8	400	0.0000	0.0000	0.0008	0.3450	0.2300	
9	450	0.0163	4.0669	0.0163	4.0741	0.4000	
10	500	0.0000	0.0000	0.0008	0.4312	0.1840	
11	550	0.0152	4.6178	0.0153	4.6239	0.3300	
12	600	0.0000	0.0000	0.0008	0.5175	0.1533	
13	650	0.0141	6.6992	0.0141	6.7139	0.2100	
14	700	0.0000	0.0000	0.0008	0.6037	0.1314	
15	750	0.0128	8.5368	0.0128	8.5449	0.1500	
16	800	0.0000	0.0000	0.0008	0.6900	0.1150	
17	850	0.0115	8.6774	0.0115	8.6928	0.1324	
18	900	0.0000	0.0000	0.0008	0.7762	0.1022	
19	950	0.0102	8.5771	0.0102	8.6073	0.1184	
20	1000	0.0000	0.0000	0.0008	0.8293	0.0920	
21	1050	0.0089	8.2724	0.0089	8.3171	0.1071	
22	1100	0.0000	0.0000	0.0008	0.9122	0.0836	
23	1150	0.0077	7.8560	0.0078	7.9237	0.0978	
24	1200	0.0000	0.0000	0.0008	0.9951	0.0767	
25	1250	0.0066	7.3486	0.0067	7.4259	0.0900	
26	1300	0.0000	0.0000	0.0008	1.0781	0.0708	
27	1350	0.0057	6.8761	0.0058	6.9580	0.0833	
28	1400	0.0000	0.0000	0.0008	1.1610	0.0657	
29	1450	0.0049	6.3186	0.0051	6.6081	0.0776	
30	1500	0.0000	0.0000	0.0008	1.2439	0.0613	
31	1550	0.0000	0.0000	0.0046	6.3911	0.0726	
32	1600	0.0000	0.0000	0.0008	1.3269	0.0575	
33	1650	0.0000	0.0000	0.0044	6.4006	0.0682	
34	1700	0.0000	0.0000	0.0008	1.4098	0.0541	
35	1750	0.0000	0.0000	0.0042	6.5511	0.0643	
36	1800	0.0000	0.0000	0.0008	1.4927	0.0511	
37	1850	0.0000	0.0000	0.0042	6.8251	0.0608	
38	1900	0.0000	0.0000	0.0008	1.5756	0.0484	
39	1950	0.0000	0.0000	0.0041	7.0882	0.0577	
40	2000	0.0000	0.0000	0.0008	1.7249	0.0460	

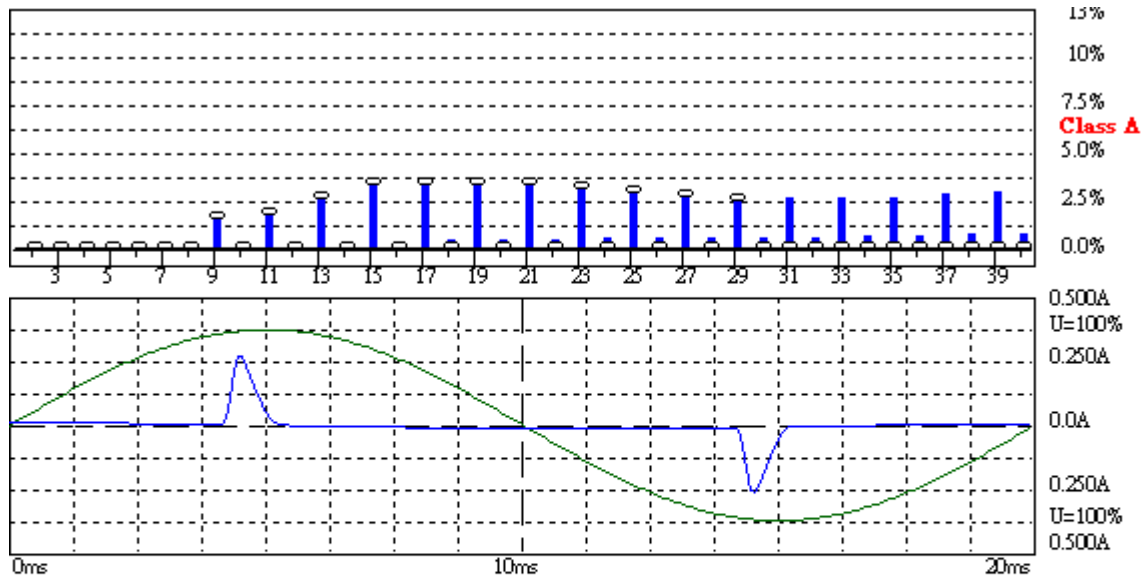

Harmonic Emission - IEC 61000-3-2 , EN 61000-3-2 , (EN60555-2)

2007/12/26 14:14:07

U_{rms} = 230.3 V P = 4.798 W THC = 0.049 A
I_{rms} = 0.052 A pf = 0.408

Range: 0.5 A
V_{nom}: 230 V
TestTime: 5 min (100%)

Test completed, Result: PASSED

**EUT2**

Date : 2007/12/26 14:36:02 V4.16

Urms =	230.3V	Freq =	49.987	Range:	0.5 A
Irms =	0.061A	Ipk =	0.319A	cf =	5.262
P =	5.780W	S =	13.94VA	pf =	0.414
THDi =	90.3 %	THDu =	0.10 %	Class A	

Test - Time : 5min (100 %)

Test completed, Result: PASSED

Order	Freq. [Hz]	Iavg [A]	Iavg%L [%]	Imax [A]	Imax%L [%]	Limit [A]	Status
1	50	0.0265		0.0270			
2	100	0.0000	0.0000	0.0008	0.0706	1.0800	
3	150	0.0224	0.9745	0.0224	0.9752	2.3000	
4	200	0.0000	0.0000	0.0007	0.1703	0.4300	
5	250	0.0218	1.9114	0.0218	1.9114	1.1400	
6	300	0.0000	0.0000	0.0008	0.2543	0.3000	
7	350	0.0208	2.6951	0.0208	2.6990	0.7700	
8	400	0.0000	0.0000	0.0007	0.3184	0.2300	
9	450	0.0194	4.8593	0.0194	4.8599	0.4000	
10	500	0.0000	0.0000	0.0007	0.3981	0.1840	
11	550	0.0179	5.4109	0.0179	5.4192	0.3300	
12	600	0.0000	0.0000	0.0007	0.4777	0.1533	
13	650	0.0161	7.6707	0.0161	7.6730	0.2100	
14	700	0.0000	0.0000	0.0007	0.5573	0.1314	
15	750	0.0143	9.5051	0.0143	9.5215	0.1500	
16	800	0.0000	0.0000	0.0007	0.6104	0.1150	
17	850	0.0124	9.3649	0.0124	9.3845	0.1324	
18	900	0.0000	0.0000	0.0007	0.6866	0.1022	
19	950	0.0106	8.9623	0.0107	8.9939	0.1184	
20	1000	0.0000	0.0000	0.0007	0.7629	0.0920	
21	1050	0.0090	8.3789	0.0090	8.4025	0.1071	
22	1100	0.0000	0.0000	0.0007	0.8392	0.0836	
23	1150	0.0076	7.7753	0.0076	7.7989	0.0978	
24	1200	0.0000	0.0000	0.0007	0.9155	0.0767	
25	1250	0.0065	7.2638	0.0066	7.2903	0.0900	
26	1300	0.0000	0.0000	0.0007	0.9918	0.0708	
27	1350	0.0058	7.0119	0.0059	7.0679	0.0833	
28	1400	0.0000	0.0000	0.0007	1.0681	0.0657	
29	1450	0.0055	7.0439	0.0055	7.0801	0.0776	
30	1500	0.0000	0.0000	0.0007	1.1444	0.0613	
31	1550	0.0053	7.2819	0.0053	7.3161	0.0726	
32	1600	0.0000	0.0000	0.0007	1.2207	0.0575	
33	1650	0.0052	7.6924	0.0053	7.7433	0.0682	
34	1700	0.0000	0.0000	0.0007	1.2970	0.0541	
35	1750	0.0052	8.0592	0.0052	8.1177	0.0643	
36	1800	0.0000	0.0000	0.0007	1.4330	0.0511	
37	1850	0.0051	8.3914	0.0052	8.4812	0.0608	
38	1900	0.0000	0.0000	0.0007	1.4496	0.0484	
39	1950	0.0000	0.0298	0.0050	8.6751	0.0577	
40	2000	0.0000	0.0000	0.0007	1.5922	0.0460	

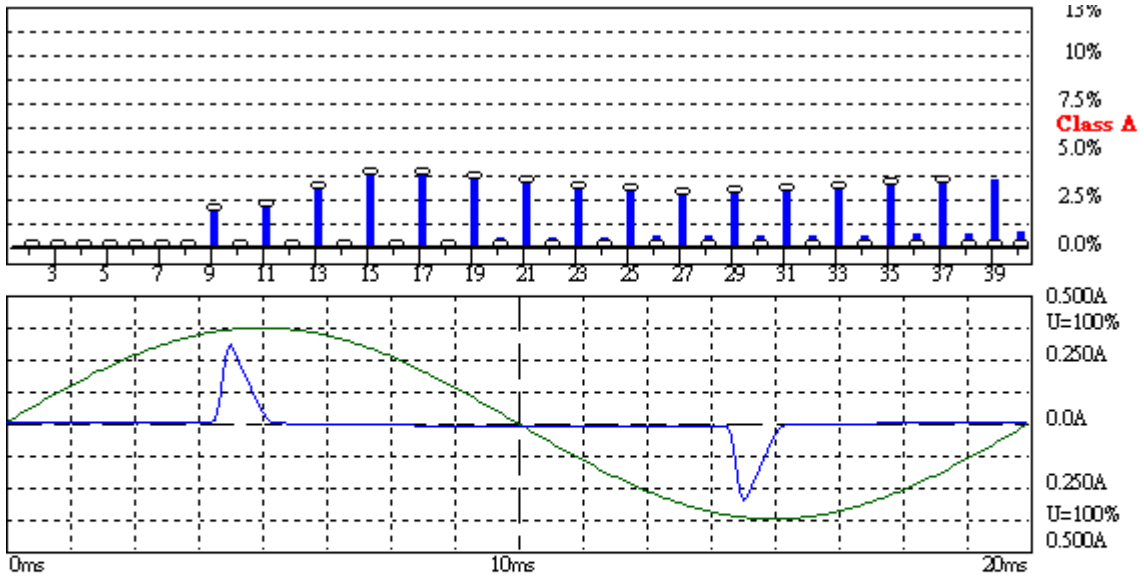

Harmonic Emission - IEC 61000-3-2 , EN 61000-3-2 , (EN60555-2)

2007/12/26 14:36:02

U_{rms} = 230.3 V P = 5.780 W THC = 0.057 A
I_{rms} = 0.061 A pf = 0.414

Range: 0.5 A
V_{nom}: 230 V
TestTime: 5 min (100%)

Test completed, Result: PASSED

**EUT3**

Date : 2007/12/26 14:55:09 V4.16

Urms =	230.3V	Freq =	49.987	Range:	10 A
Irms =	0.063A	Ipk =	0.278A	cf =	4.385
P =	4.172W	S =	14.62VA	pf =	0.285
THDi =	87.7 %	THDu =	0.10 %	Class A	

Test - Time : 5min (100 %)

Test completed, Result: PASSED

Order	Freq. [Hz]	Iavg [A]	Iavg%L [%]	Imax [A]	Imax%L [%]	Limit [A]	Status
1	50	0.0208		0.0208			
2	100	0.0000	0.0000	0.0006	0.0565	1.0800	
3	150	0.0122	0.5307	0.0122	0.5307	2.3000	
4	200	0.0000	0.0000	0.0006	0.1419	0.4300	
5	250	0.0128	1.1243	0.0128	1.1243	1.1400	
6	300	0.0000	0.0000	0.0006	0.2035	0.3000	
7	350	0.0125	1.6185	0.0128	1.6646	0.7700	
8	400	0.0000	0.0000	0.0006	0.2654	0.2300	
9	450	0.0116	2.9037	0.0122	3.0518	0.4000	
10	500	0.0000	0.0000	0.0006	0.3317	0.1840	
11	550	0.0116	3.5141	0.0116	3.5141	0.3300	
12	600	0.0000	0.0000	0.0006	0.3981	0.1533	
13	650	0.0110	5.2313	0.0110	5.2316	0.2100	
14	700	0.0000	0.0000	0.0006	0.4644	0.1314	
15	750	0.0098	6.5104	0.0098	6.5104	0.1500	
16	800	0.0000	0.0000	0.0006	0.5307	0.1150	
17	850	0.0092	6.9173	0.0092	6.9173	0.1324	
18	900	0.0000	0.0000	0.0006	0.5971	0.1022	
19	950	0.0085	7.2157	0.0085	7.2157	0.1184	
20	1000	0.0000	0.0000	0.0006	0.6634	0.0920	
21	1050	0.0073	6.8359	0.0073	6.8359	0.1071	
22	1100	0.0000	0.0000	0.0006	0.7298	0.0836	
23	1150	0.0067	6.8631	0.0067	6.8631	0.0978	
24	1200	0.0000	0.0000	0.0006	0.7961	0.0767	
25	1250	0.0061	6.7817	0.0061	6.7817	0.0900	
26	1300	0.0000	0.0000	0.0006	0.8625	0.0708	
27	1350	0.0054	6.5306	0.0055	6.5918	0.0833	
28	1400	0.0000	0.0000	0.0006	0.9288	0.0657	
29	1450	0.0035	4.5200	0.0049	6.2934	0.0776	
30	1500	0.0000	0.0000	0.0006	0.9951	0.0613	
31	1550	0.0000	0.0000	0.0043	5.8865	0.0726	
32	1600	0.0000	0.0000	0.0006	1.0615	0.0575	
33	1650	0.0000	0.0000	0.0037	5.3711	0.0682	
34	1700	0.0000	0.0000	0.0006	1.1278	0.0541	
35	1750	0.0000	0.0000	0.0037	5.6966	0.0643	
36	1800	0.0000	0.0000	0.0006	1.1942	0.0511	
37	1850	0.0000	0.0000	0.0031	5.0184	0.0608	
38	1900	0.0000	0.0000	0.0006	1.2605	0.0484	
39	1950	0.0000	0.0000	0.0031	5.2897	0.0577	
40	2000	0.0000	0.0000	0.0006	1.3269	0.0460	

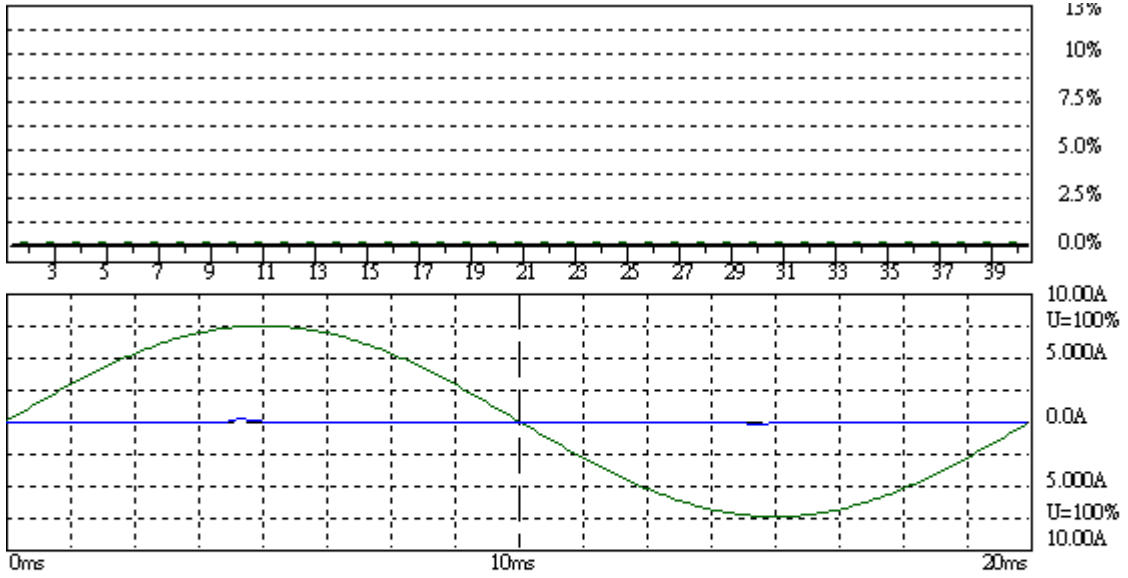

Harmonic Emission - IEC 61000-3-2 , EN 61000-3-2 , (EN60555-2)

2007/12/26 14:55:09

U_{rms} = 230.3 V P = 4.172 W THC = 0.037 A
I_{rms} = 0.063 A pf = 0.285

Range: 10 A
V_{nom}: 230 V
TestTime: 5 min (100%)

Test completed, Result: PASSED



7.4 VOLTAGE FLUCTUATION AND FLICKER TEST

TEST EQUIPMENTS

Manufacturer or Type	Model No.	Serial No.	Date of Calibration	Calibration Period
EMC PARTNER	HARMONIC-1000	071	November 10, 2007	1 Year

TESTING REQUIREMENT AND PROCEDURE

The test standard was based on EN 61000-3-3:1995 + A1:2001 + A2:2005.



SUMMARY OF TEST

EUT1

Date : 2007/12/26 14:28:13 V4.16

Urms =	230.3V	Freq =	49.987	Range:	0.5 A
Irms =	0.055A	Ipk =	0.322A	cf =	5.836
P =	4.798W	S =	12.71VA	pf =	0.378

Test - Time : 1 x 10min = 10min (100 %)

LIN (Line Impedance Network) : L: 0.24ohm +j0.15ohm N: 0.16ohm +j0.10ohm

Limits :	Plt :	0.65	Pst :	1.00
	dmax :	4.00 %	dc :	3.30 %
	dtLim:	3.30 %	dt>Lim:	500ms

Test completed, Result: PASSED

Flickermeter 1000-4-15 for 230V/50Hz

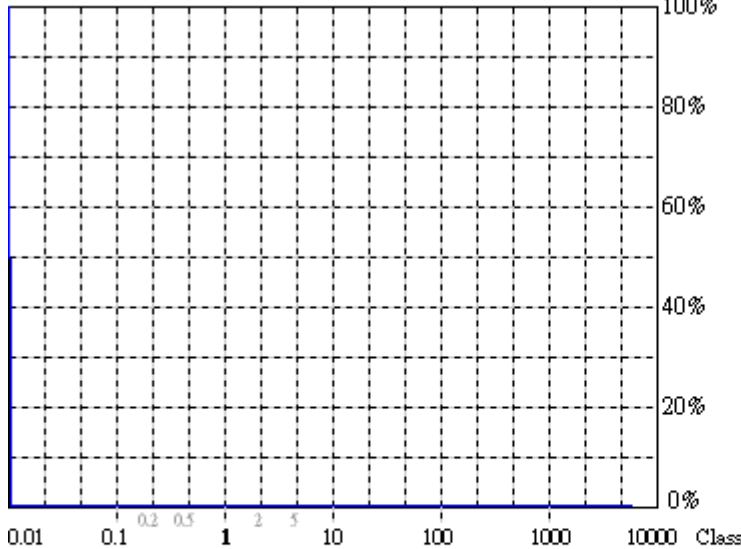

Actual Flicker (Fli):	0.00
Short-term Flicker (Pst):	0.07
Limit (Pst):	1.00
Long-term Flicker (Plt):	0.07
Limit (Plt):	0.65
Maximum Relative Volt. Change (dmax):	0.00%
Limit (dmax):	4.00%
Relative Steady-state Voltage Change (dc):	0.09%
Limit (dc):	3.30%
Maximum Interval exceeding 3.30% (dt):	0.00ms
Limit (dt>Lim):	500ms

Flicker Emission - IEC 61000-3-3 , EN 61000-3-3 , (EN60555-3)

2007/12/26 14:28:13

Urms =	230.3	V	P =	4.798	W
Irms =	0.055	A	pf =	0.378	

Range:	0.5 A
V-nom:	230 V
TestTime:	10 min (100%)

Test completed, Result: PASSED



EUT2

Date : 2007/12/26 14:47:52 V4.16

Urms =	230.3V	Freq =	49.987	Range:	0.5 A
Irms =	0.065A	Ipk =	0.366A	cf =	5.643
P =	5.767W	S =	14.96VA	pf =	0.386

Test - Time : 1 x 10min = 10min (100 %)

LIN (Line Impedance Network) : L: 0.24ohm +j0.15ohm N: 0.16ohm +j0.10ohm

Limits :	Plt :	0.65	Pst :	1.00
	dmax :	4.00 %	dc :	3.30 %
	dtLim:	3.30 %	dt>Lim:	500ms

Test completed, Result: PASSED

Flickermeter 1000-4-15 for 230V/50Hz

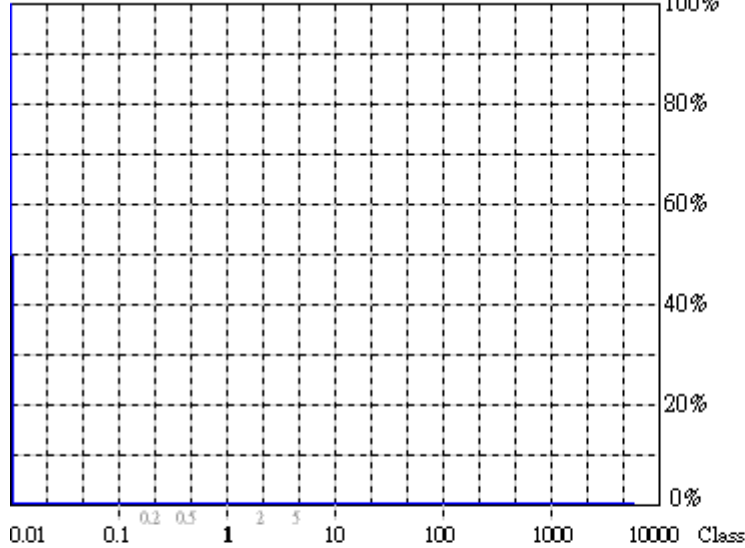

Actual Flicker (Fli):	0.00
Short-term Flicker (Pst):	0.07
Limit (Pst):	1.00
Long-term Flicker (Plt):	0.07
Limit (Plt):	0.65
Maximum Relative Volt. Change (dmax):	0.00%
Limit (dmax):	4.00%
Relative Steady-state Voltage Change (dc):	0.00%
Limit (dc):	3.30%
Maximum Interval exceeding 3.30% (dt):	0.00ms
Limit (dt>Lim):	500ms

Flicker Emission - IEC 61000-3-3 , EN 61000-3-3 , (EN60555-3)

2007/12/26 14:47:52

Urms =	230.3 V	P =	5.767 W
Irms =	0.065 A	pf =	0.386

Range:	0.5 A
V-nom:	230 V
TestTime:	10 min (100%)

Test completed, Result: PASSED



EUT3

Date : 2007/12/26 15:06:50 V4.16

Urms =	230.3V	Freq =	49.974	Range:	0.5 A
Irms =	0.042A	Ipk =	0.257A	cf =	6.092
P =	3.608W	S =	9.727VA	pf =	0.371

Test - Time : 1 x 10min = 10min (100 %)

LIN (Line Impedance Network) : L: 0.24ohm +j0.15ohm N: 0.16ohm +j0.10ohm

Limits :	Plt :	0.65	Pst :	1.00
	dmax :	4.00 %	dc :	3.30 %
	dtLim:	3.30 %	dt>Lim:	500ms

Test completed, Result: PASSED

Flickermeter 1000-4-15 for 230V/50Hz

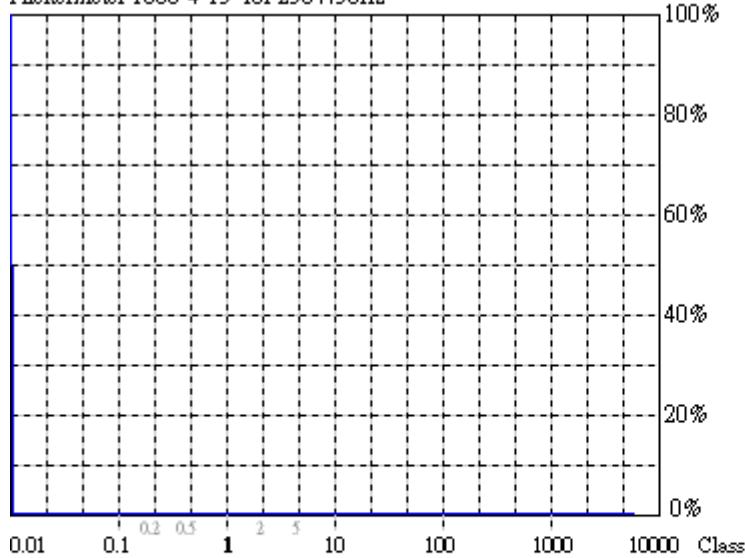

Actual Flicker (Fli):	0.00
Short-term Flicker (Pst):	0.07
Limit (Pst):	1.00
Long-term Flicker (Plt):	0.07
Limit (Plt):	0.65
Maximum Relative Volt. Change (dmax):	0.00%
Limit (dmax):	4.00%
Relative Steady-state Voltage Change (dc):	0.01 %
Limit (dc):	3.30%
Maximum Interval exceeding 3.30% (dt):	0.00ms
Limit (dt>Lim):	500ms

Flicker Emission - IEC 61000-3-3 , EN 61000-3-3 , (EN60555-3)

2007/12/26 15:06:50

Urms =	230.3 V	P =	3.608 W
Irms =	0.042 A	pf =	0.371

Range:	Auto
V-nom:	230 V
TestTime:	10 min (100%)

Test completed, Result: PASSED



8. IMMUNITY TEST

TEST EQUIPMENT

Manufacturer or Type	Model No.	Date of Calibration
HP VEI8 PIII	DPTC-17	N/A
HP VGA Monitor	D1193A	N/A
HP Keyboard	C1405B #ABO	N/A
HP VE 4/66 Computer	VE 4/66	N/A
IBM VGA Monitor	2248-002	N/A
HP Keyboard	C1405B#ABO	N/A
KeyTek Control Center	E-CLASS SERIES-100	N/A
Pacific Programmable Controller	ERI3	June 05, 2007
Pacific AC Power Source	EP74	August 03, 2007
KeyTek Control Center	E-CLASS SERIES-100	N/A
KeyTek EFT/B Source	E421	September 07, 2007
KeyTek Surge Network	E510, E503, E502	April 23, 2007
KeyTek EFT/B & Surge Coupler/Decoupler	E4552	April 23, 2007
KeyTek Swell/Dip Interrupt Source	EP62	November 27, 2007
Noise Lightning Surge Simulator	LSS-712SM	April 23, 2007
Noise Impulse Noise Simulator	INS-410	July 12, 2007
NoiseKen ESD Simulator	ESS-2000	April 16, 2007
KeyTek Surge Network	E506, E510A, E4554	April 17, 2007
KeyTek Surge Network	E505A	November 27, 2007
SCHWARZBGCK Bilog Antenna	VULB 9163	July 20, 2007
R&S Signal Generator Freq. Range : 9KHz ~ 2.08GHz	SMY02	December 12, 2007
HOLADAY FIELD PROBE	J1-4422	November 01, 2007
SCHAFFNER Coupling Decoupling Network Freq. range : 150KHz ~ 230MHz	CDN-M325S	August 09, 2007
SCHAFFNER Coupling Decoupling Network Freq. range : 150KHz ~ 230MHz	CDN-M225S	November 28, 2007
AR Amplifier Freq. Range : 10KHz ~ 220MHz	200W/150L	N/A
AR Amplifier Freq. Range : 25MHz ~ 1000MHz	100W1000M1A	N/A
DANA TORINO-ITALY Power Frequenty Magnetic Field	DAS-G60 DAS 1S 1000	September 29, 2007
SCHAFFNER EM CLAMP	KEMZ 801	December 06, 2007
MILMEGA LINEAR AMPLIFIER Freq. range : 0.8 ~ 2.5 GHz	AS0825-35	N/A
FRANKONIA Conducted Immunity Test System	CIT-10/75	March 13, 2007

**PERFORMANCE CRITERIA DESCRIPTION**

Criterion A	The equipment shall continue to operate as intended. No degradation of performance or loss of function is allowed below a performance level specified by the manufacturer.
Criterion B	After the test the equipment shall continue to operate as intended. No degradation of performance or loss of function is allowed after the application of the phenomena below a performance level specified by the manufacturer. During the test, degradation of performance is allowed however. No change of actual operating state or stored data is allowed.
Criterion C	Loss of function is allowed, provided the function is self recoverable or can be restored by the operation of the controls by the user in accordance with the manufacturers instructions.

DESCRIPTION OF PERIPHERALS

Description of peripherals is shown in section 6.

EUT & PERIPHERALS SETUP DIAGRAM

EUT & peripherals setup diagram is shown in appendix setup photos.

EUT OPERATING CONDITION

The EUT operating condition is shown in section 6.

8.1 ELECTROSTATIC DISCHARGE TEST

CLIMATIC CONDITIONS

Ambient temperature : 24 °C ~ 26 °C

Relative humidity : 55 % ~ 60 % RH

Atmospheric pressure : 99.2 kpa

TEST REQUIREMENT AND PROCEDURE

The test standard was based on EN 55024:1998 + A1:2001 + A2:2003 and IEC 61000-4-2:1995 + A1:1998 + A2:2000.

TEST CONDITIONS

Source voltage / frequency : 230VAC/50Hz, Single phase

R-C network : 330 Ω, 150 PF.

Test Level :

Air Discharge : 2 , 4 , 8 KV

Contact Discharge : 2 , 4 KV

HCP Discharge : 2 , 4 KV

VCP Discharge : 2 , 4 KV

Polarity : Positive / Negative

Number of test :

25 Discharges / Sensitive Polarity for Contact, HCP and VCP Discharge.

Time between test : 1 Sec.

TEST RESULTS

Severity Level	Test Requirement Polarity	EN 55024:1998 + A1:2001 + A2:2003 requirement				Performance verification (criteria)				Test results
		Air discharge	Contact discharge	HCP discharge	VCP discharge	Air discharge	Contact discharge	HCP discharge	VCP discharge	
2 KV	+	B	B	B	B	B	A	A	A	PASS
	-	B	B	B	B	B	A	A	A	PASS
4 KV	+	B	B	B	B	B	A	A	A	PASS
	-	B	B	B	B	B	A	A	A	PASS
8 KV	+	B	NR	NR	NR	B	NR	NR	NR	PASS
	-	B	NR	NR	NR	B	NR	NR	NR	PASS

Note : NR means there is no requirement.

THE TESTED POINTS OF EUT

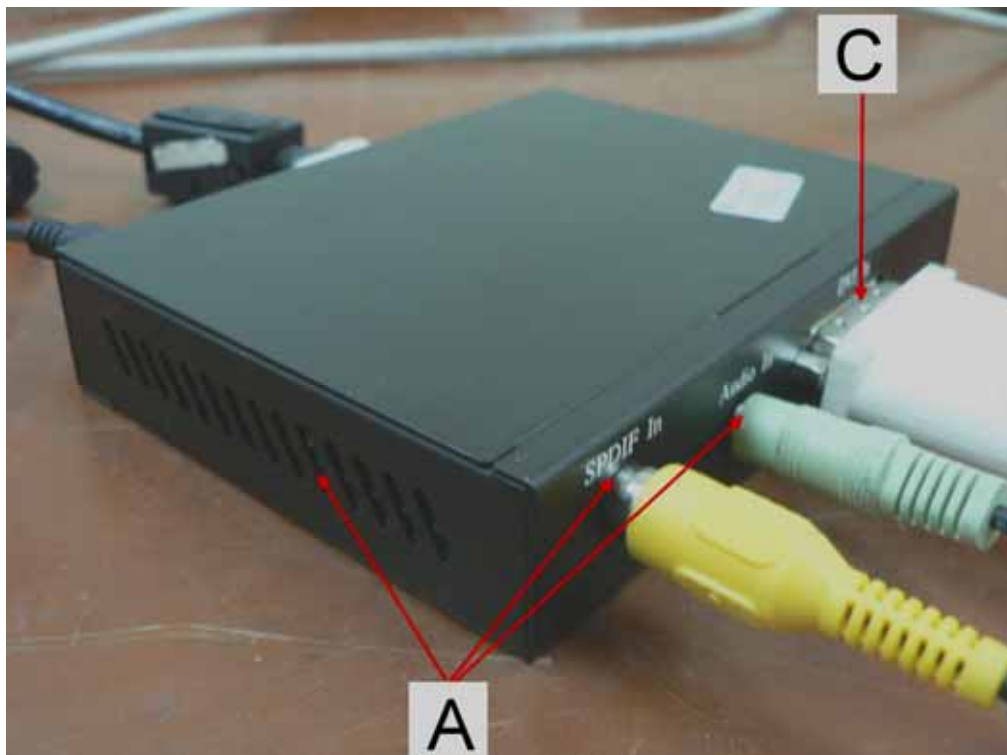
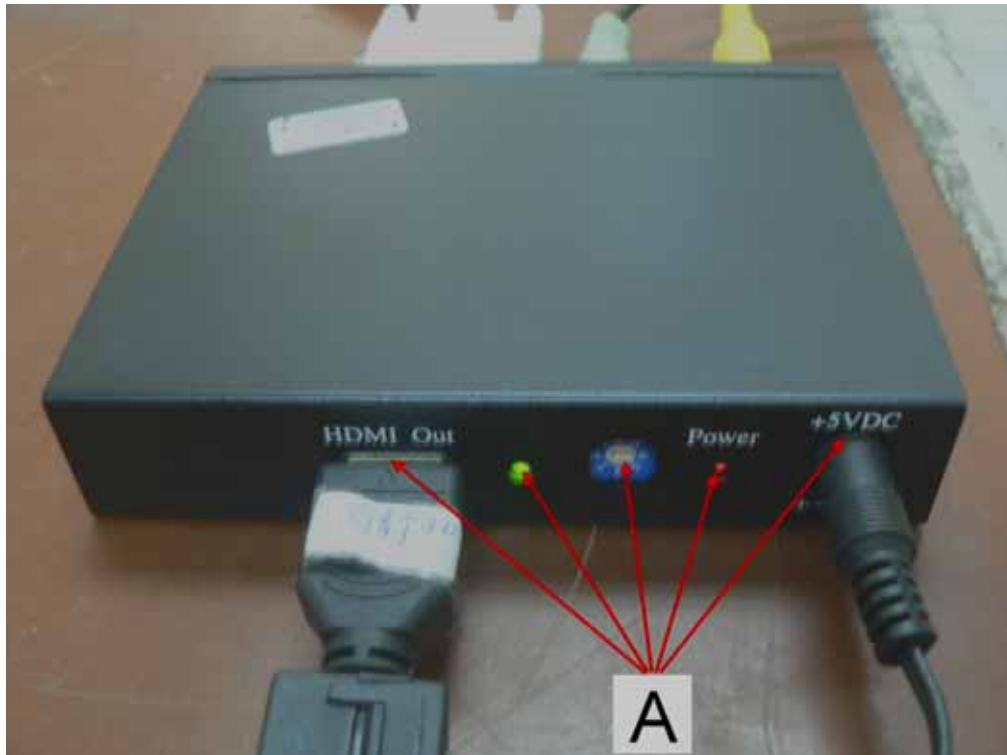

A : Air Discharge ; C : Contact Discharge

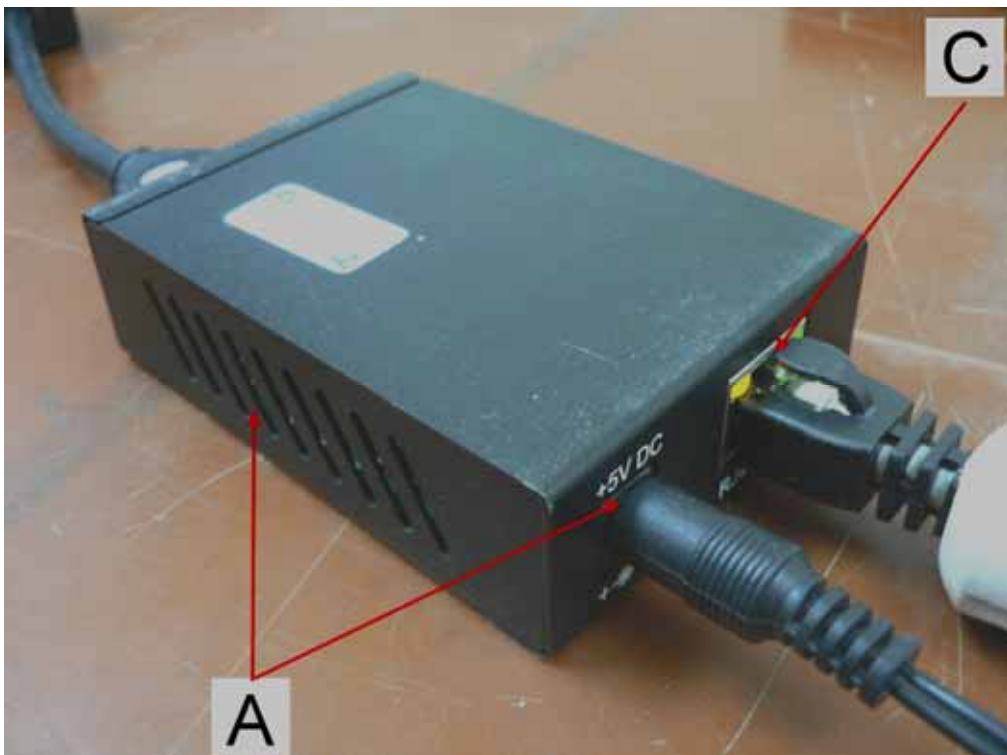
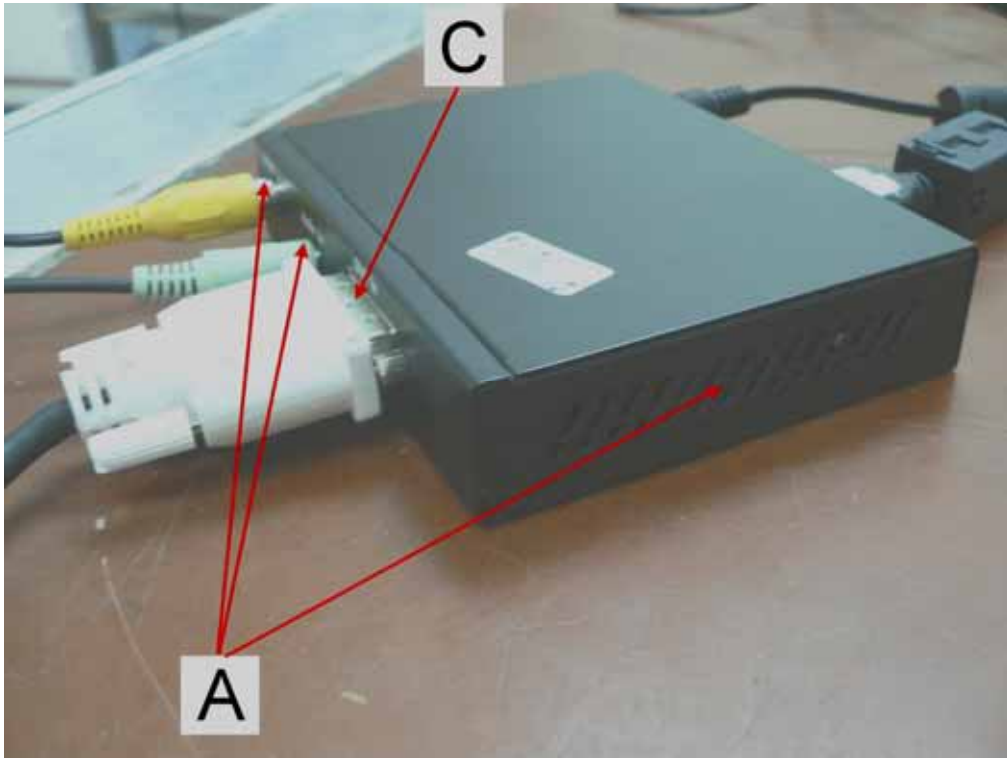

A : Air Discharge ; C : Contact Discharge

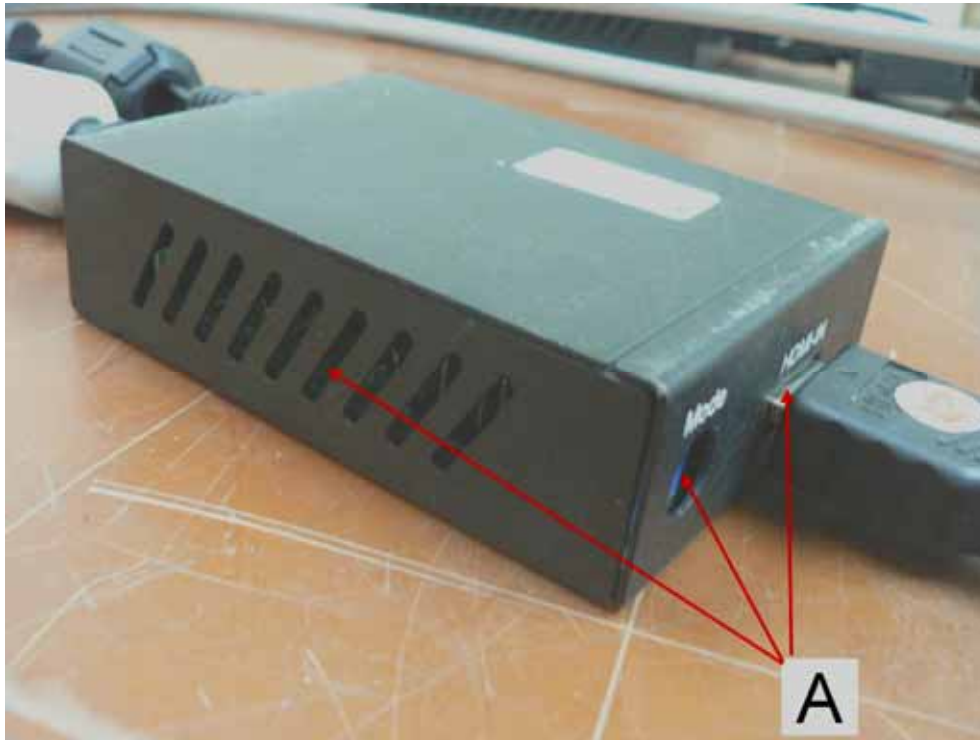

A : Air Discharge

8.2 RADIATED SUSCEPTIBILITY TEST

CLIMATIC CONDITIONS

Ambient temperature : 24 °C ~ 26 °C

Relative humidity : 55 % ~ 65 % RH

Atmospheric pressure : 99.0 kpa

TEST REQUIREMENT AND PROCEDURE

The test standard was based on EN 55024:1998 + A1:2001 + A2:2003 and

IEC 61000-4-3:2002 + A1:2002.

TEST CONDITIONS

Source voltage / frequency : 230VAC/50Hz, Single phase

Sweeping frequency : 80 MHz ~ 1 GHz.

Test Level : 3V/m.

Measuring distance : 3 meters

The four sides of EUT are tested (Front, Rear, Left, Right).

Antenna Polarization : Horizontal and Vertical polarizations.

The generated signal amplitude was 80% AM (1KHz) amplitude modulated, the step size was 1% and test duration time was 1000ms.

STRUCTURE OF THE TEST

Setup configuration

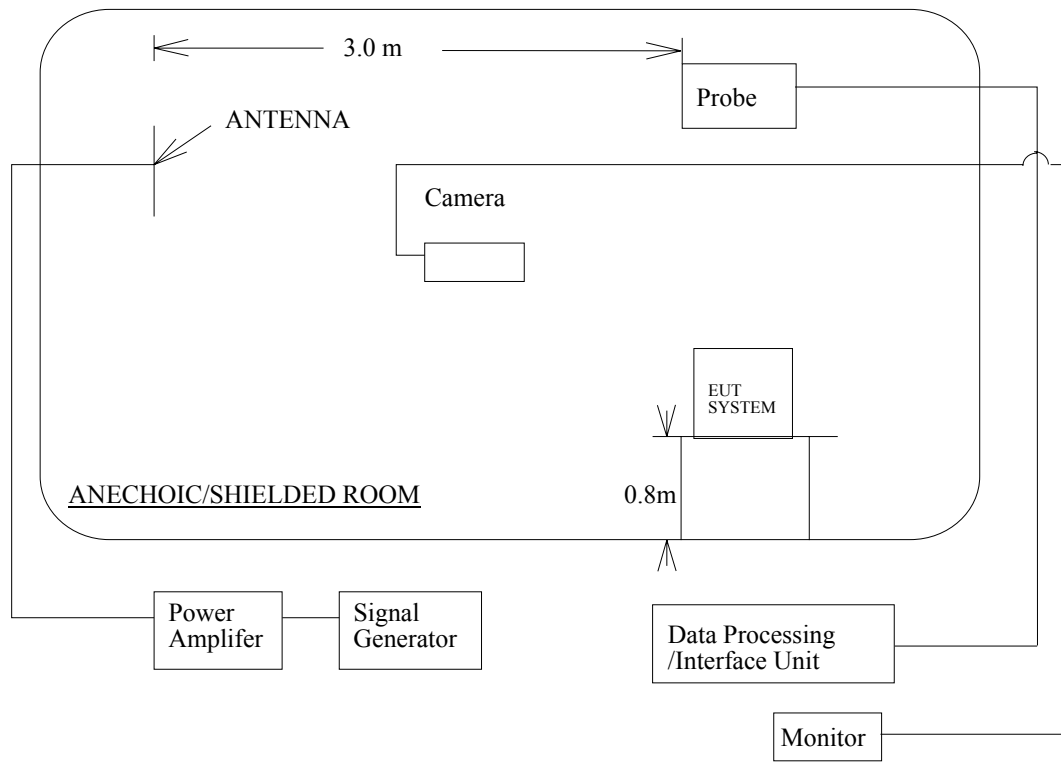

TEST RESULT

Frequency range : 80MHz ~ 1GHz

Severity level (V/m)	EN 55024:1998 + A1:2001 + A2:2003 requirement	Performance Verification (criteria)	Test results
3	A	A	PASS

8.3 ELECTRICAL FAST TRANSIENT/BURST TEST

CLIMATIC CONDITIONS

Ambient temperature : 24 °C ~ 26 °C

Relative humidity : 55 % ~ 65 % RH

Atmospheric pressure : 99.0 kpa

TEST REQUIREMENT AND PROCEDURE

The test standard was based on EN 55024:1998 + A1:2001 + A2:2003 and IEC 61000-4-4:2004.

TEST CONDITIONS

Source voltage / frequency : 230VAC/50Hz, Single phase

Pulse risetime / duration : 5 ns / 50 ns.

Pulse repetition : 5 KHz.

Polarity : Positive and Negative, 1 times / each condition.

Burst duration / period : 15ms / 300ms.

Test duration : 1 min.

Time between test : 10 sec.

Severity levels : 0.5 , 1 KV for AC line

0.25 , 0.5 KV For I/O line

Coupling of ac line : L , N

TEST RESULTS

Severity Level	Test Requirement Polarity	EN 55024:1998 + A1:2001 + A2:2003 requirement		Performance verification (criteria)		Test results
		AC Line	I/O Line	AC Line	I/O Line	
0.25 KV	+	N/R	B	N/R	A	PASS
	-	N/R	B	N/R	A	PASS
0.5 KV	+	B	B	A	A	PASS
	-	B	B	A	A	PASS
1 KV	+	B	N/R	A	N/R	PASS
	-	B	N/R	A	N/R	PASS



8.4 SURGE TEST

CLIMATIC CONDITION

Ambient temperature : 24 °C ~ 26 °C

Relative humidity : 55 % ~ 65 % RH

Atmospheric pressure : 99.0 kpa

TEST REQUIREMENT AND PROCEDURE

The test standard was based on EN 55024:1998 + A1:2001 + A2:2003 and

IEC 61000-4-5:1995 + A1:2000.

TEST CONDITIONS

Source voltage / frequency : 230VAC/50Hz, Single phase

Waveform of surge :

Combination wave (1.2/50µs, 8/20µs)

Output impedance : 2Ω for differential mode

Polarity : Positive and Negative, ± 5 times / each condition.

Phase angle : 0, 90, 270 degrees

Pulse repetition rate : 30 sec

Coupling mode : L → N for differential mode

Severity levels step : 0.5 , 1 KV for differential mode

TEST RESULTS

Severity Level	Test Requirement Polarity	EN 55024:1998 + A1:2001 + A2:2003 requirement	Performance verification (criteria)	Test results
		Differential mode	Differential mode	
0.5 KV	+	B	A	PASS
	-	B	A	PASS
1 KV	+	B	A	PASS
	-	B	A	PASS

Note : NR means there is no requirement.

8.5 CONDUCTED SUSCEPTIBILITY TEST

CLIMATIC CONDITIONS

Ambient temperature : 24 °C ~ 26 °C

Relative humidity : 55 % ~ 65 % RH

Atmospheric pressure : 99.0 kpa

TEST REQUIREMENT AND PROCEDURE

The test standard was based on EN 55024:1998 + A1:2001 + A2:2003 and

IEC 61000-4-6:1996 +A1:2000.

TEST CONDITIONS

Source voltage / frequency : 230VAC/50Hz, Single phase

Sweeping frequency : 150 KHz ~ 80 MHz.

Test Level : 3Vrms.

The generated signal amplitude was 80% AM (1KHz) amplitude modulated, the step size was 1% and test duration time was 1000ms.

STRUCTURE OF THE TEST

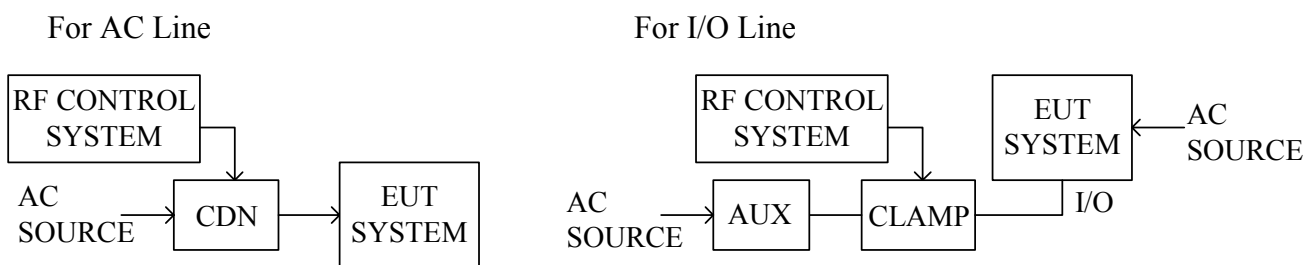

TEST RESULT

Sweeping frequency range :150KHz ~ 80MHz

Severity level (Vrms)	EN 55024:1998 + A1:2001 + A2:2003 requirement		Performance verification (criteria)		Test results
	AC Line	I/O Line	AC Line	I/O Line	
3	A	A	A	A	PASS

8.6 POWER FREQUENCY MAGNETIC FIELD IMMUNITY TEST

CLIMATIC CONDITIONS

Ambient temperature : 24 °C ~ 26 °C

Relative humidity : 55 % ~ 65 % RH

Atmospheric pressure : 99.0 kpa

TEST REQUIREMENT AND PROCEDURE

The test standard was based on EN 55024:1998 + A1:2001 + A2:2003 and IEC 61000-4-8:1993 + A1:2000.

TEST CONDITIONS

Source voltage / frequency : 230VAC/50Hz, Single phase

Test Level : 1A/m

Induction coil : The induction coil shall adequately dimensioned to surround the EUT. (Three orthogonal positions)

Output current range for continuous mode operation : 1 to 100A, divided by the coil factor.

Total distortion factor of the output current : Less than 8%.

The waveform of the output current is a sinusoid.

STRUCTURE OF THE TEST

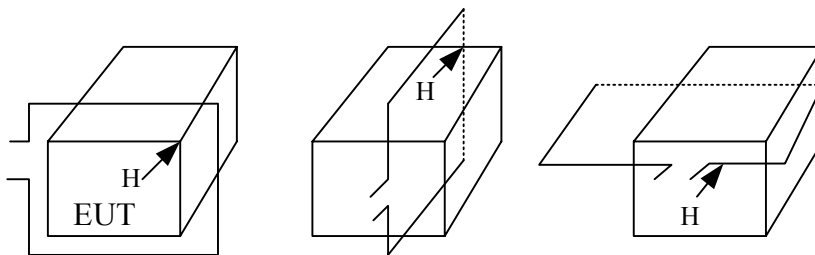

TEST RESULTS

Magnetic field strength	EN 55024 :1998 + A1:2001 + A2:2003 requirement	Performance Criteria	Test results
1 A/m	A	A	PASS

8.7 VOLTAGE DIP AND INTERRUPTION TEST

CLIMATIC CONDITIONS

Ambient temperature : 24 °C ~ 26 °C

Relative humidity : 55 % ~ 65 % RH

Atmospheric pressure : 99.0 kpa

TEST REQUIREMENT AND PROCEDURE

The test standard was based on EN 55024:1998 + A1:2001 + A2:2003 and IEC 61000-4-11:2004.

TEST CONDITIONS

Source voltage / frequency : 230VAC/50Hz, Single phase

Phase angles : 0, 45, 90, 135, 180, 225, 270, 315 degrees.

Time of interval : 10 sec.

Number of test : Sequence of 3 dips/interrupts

Voltage rise (and fall) time : 1 ~ 5 μ s.

Test severity :

Voltage dip and Interrupt reduction (%)	Test Duration (ms)
30	500
100	10
100	5000

TEST RESULTS

Voltage dip and Interrupt reduction (%)	Test duration (ms)	EN 55024:1998 + A1: 2001 + A2:2003 requirement	Performance verification (criteria)	Test results
30	500	C	A	PASS
100	10	B	A	PASS
100	5000	C	B	PASS

APPENDIX SETUP PHOTOS

RADIATED EMISSION MEASUREMENT SETUP





POWERLINE CONDUCTED EMISSION MEASUREMENT SETUP

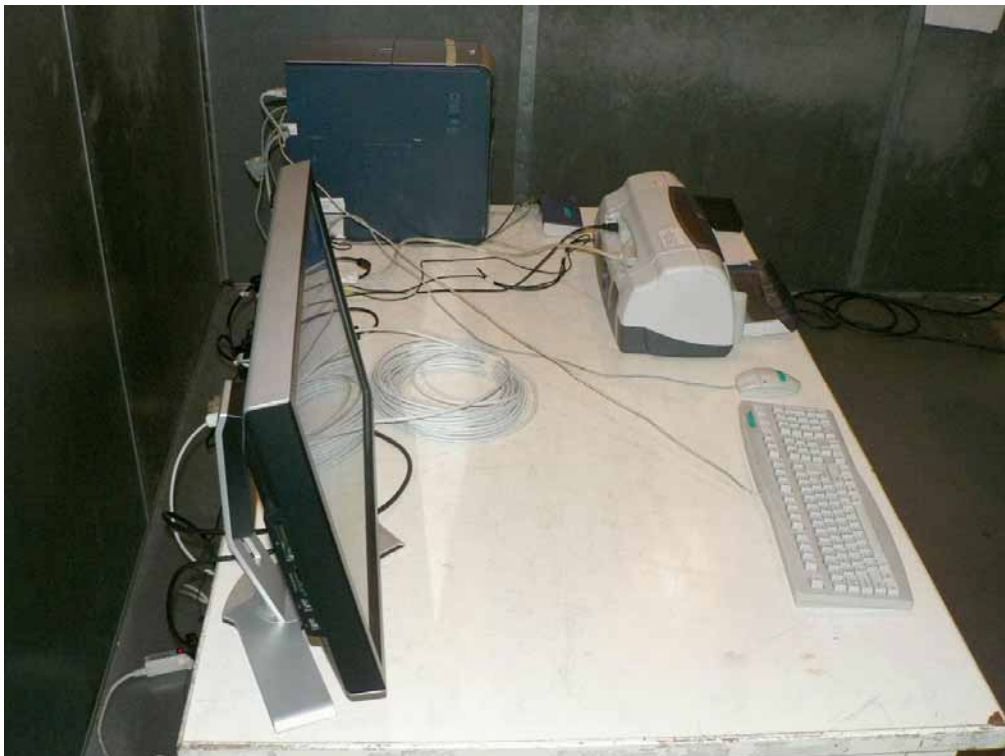

CURRENT HARMONIC SETUP



VOLTAGE FLUCTUATION AND FLICKER SETUP



ELECTROSTATIC DISCHARGE SETUP



RADIATED ELECTROMAGNETIC FIELD SETUP

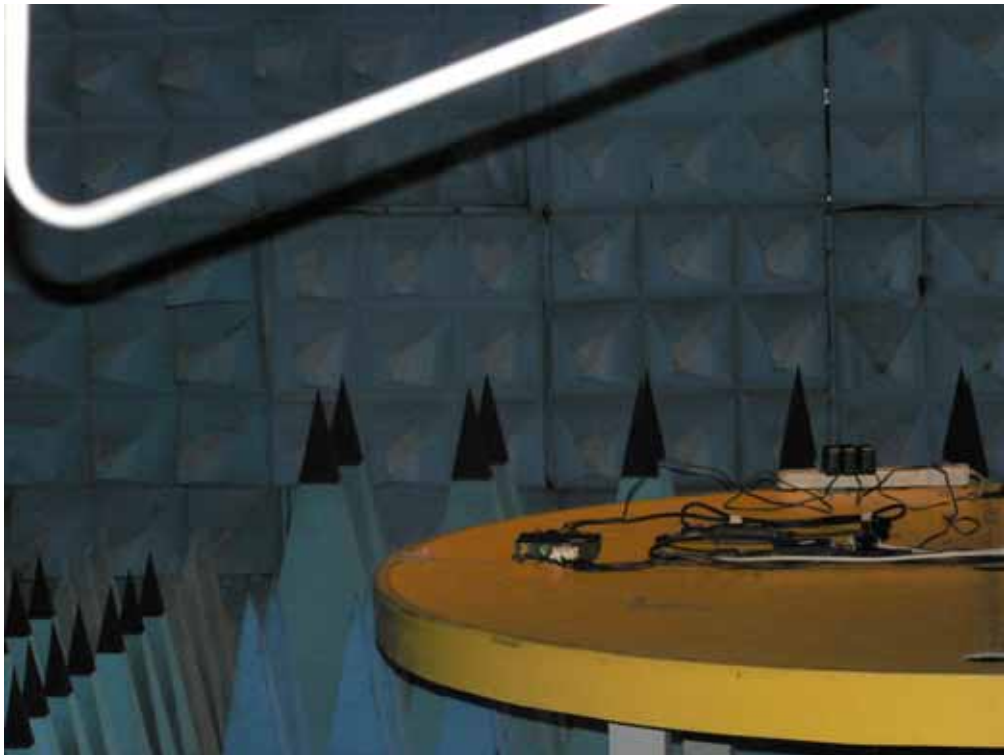

ELECTRICAL FAST TRANSIENT/BURST SETUP



EFT Clamp

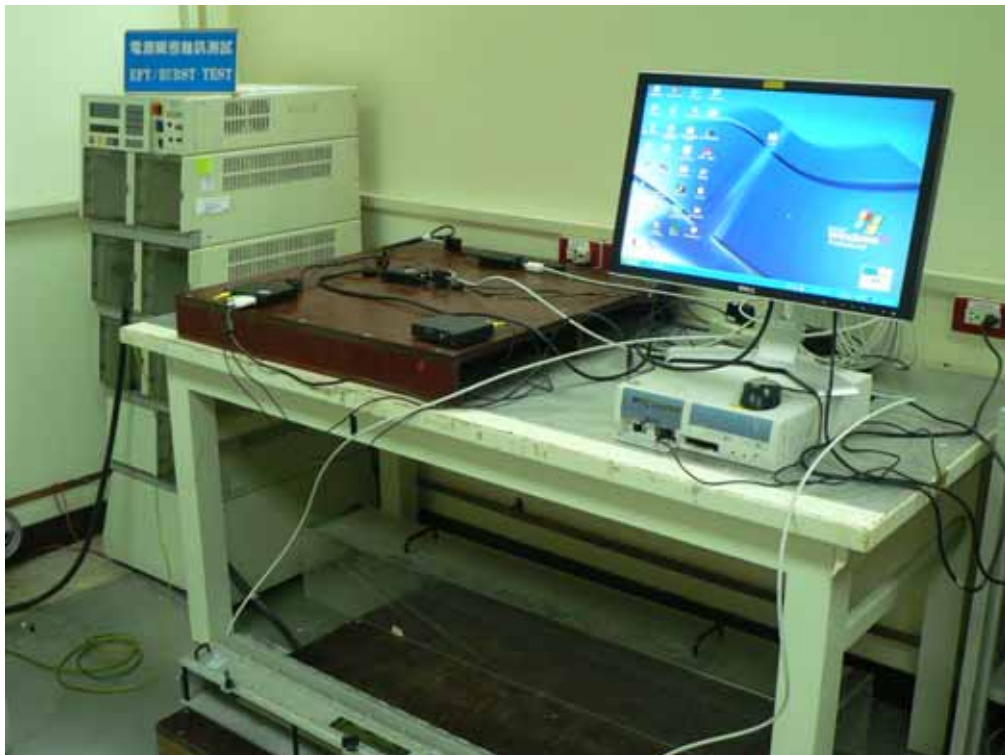

SURGE SETUP



CONDUCTED SUSCEPTIBILITY SETUP

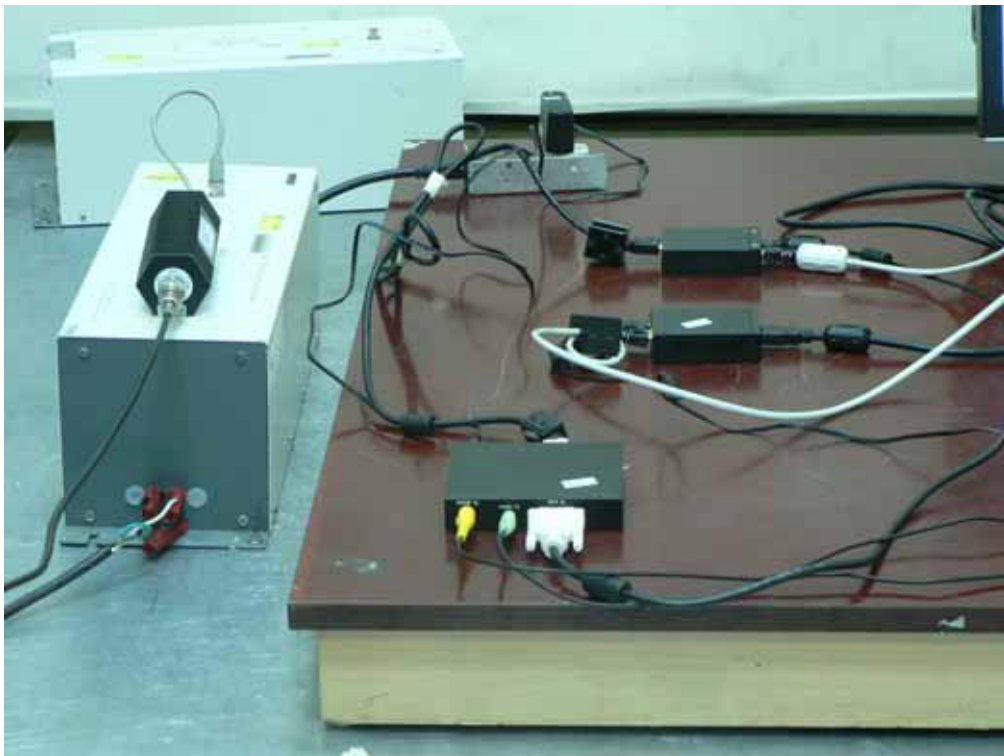

EM Clamp

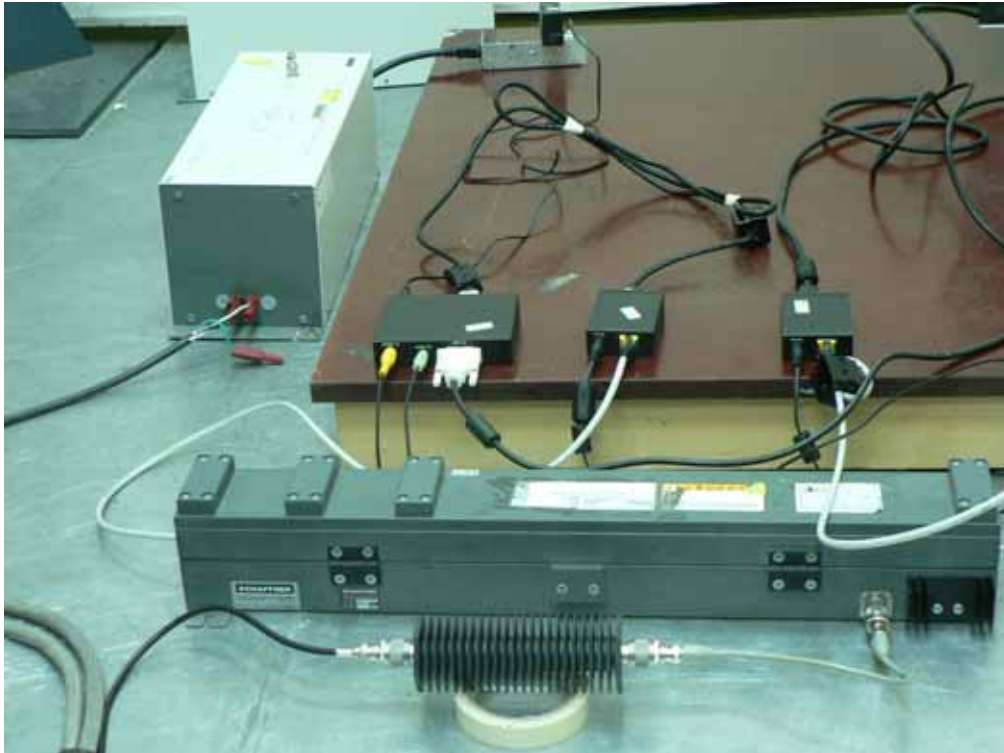

POWER FREQUENCY MAGNETIC FIELD IMMUNITY SETUP

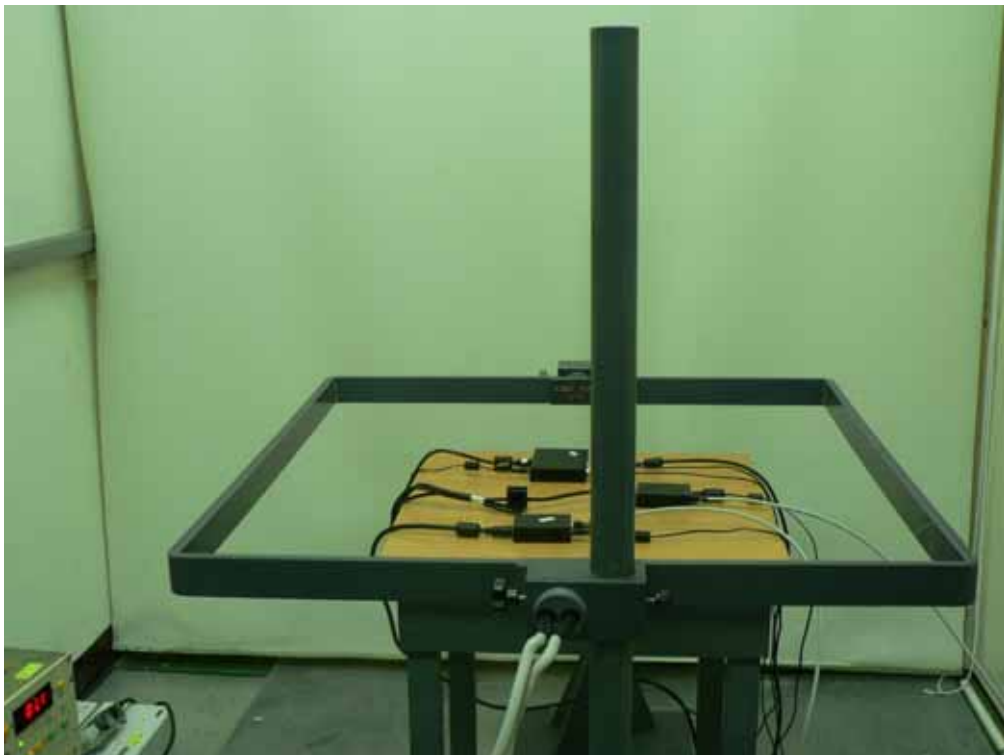
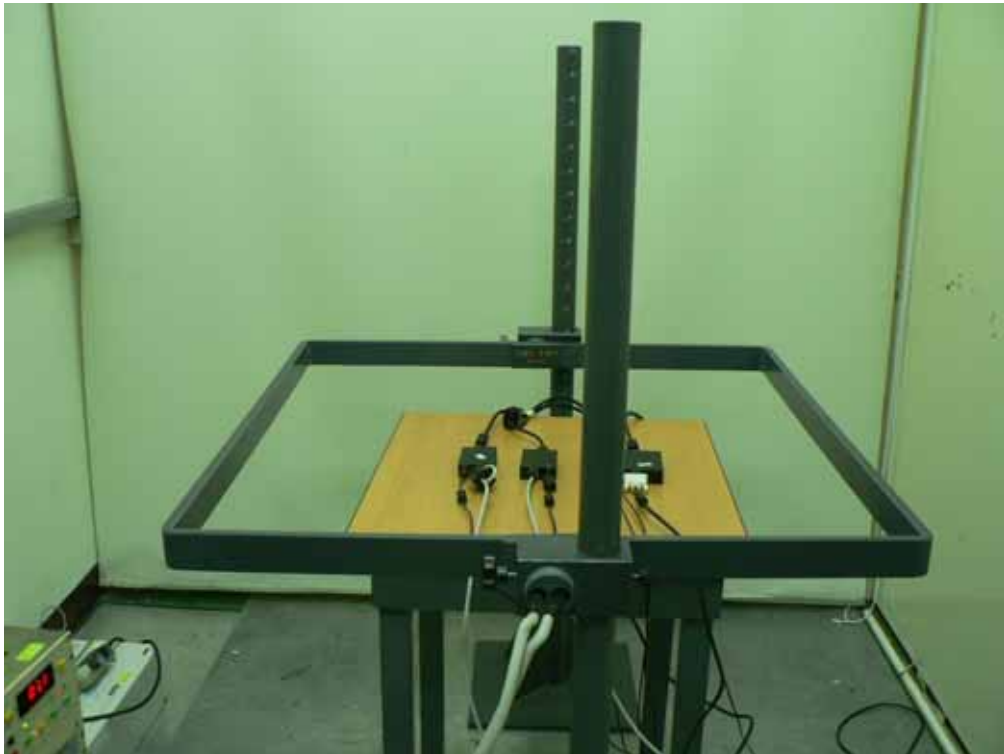



VOLTAGE DIP AND INTERRUPTION SETUP



External Photo

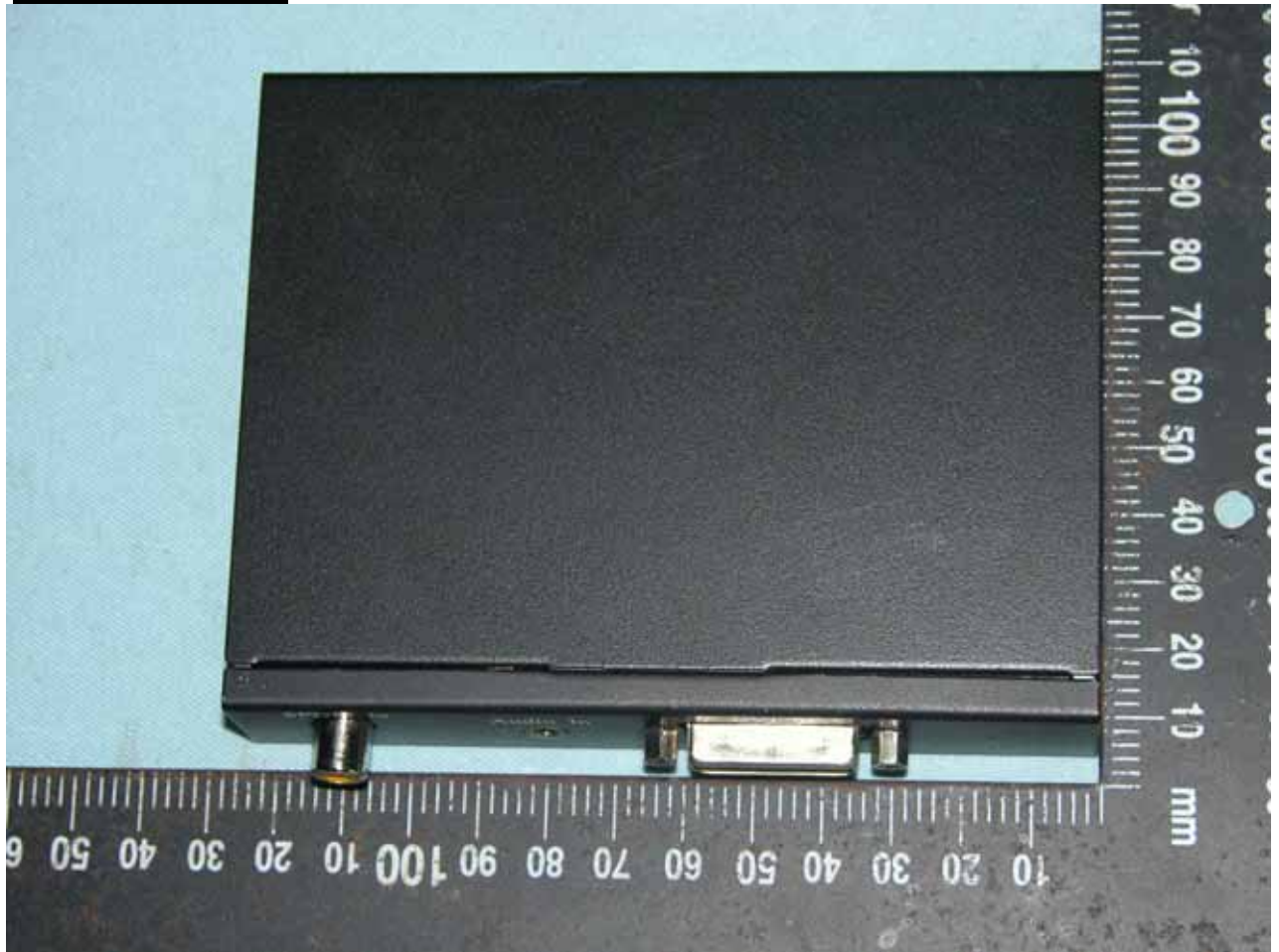



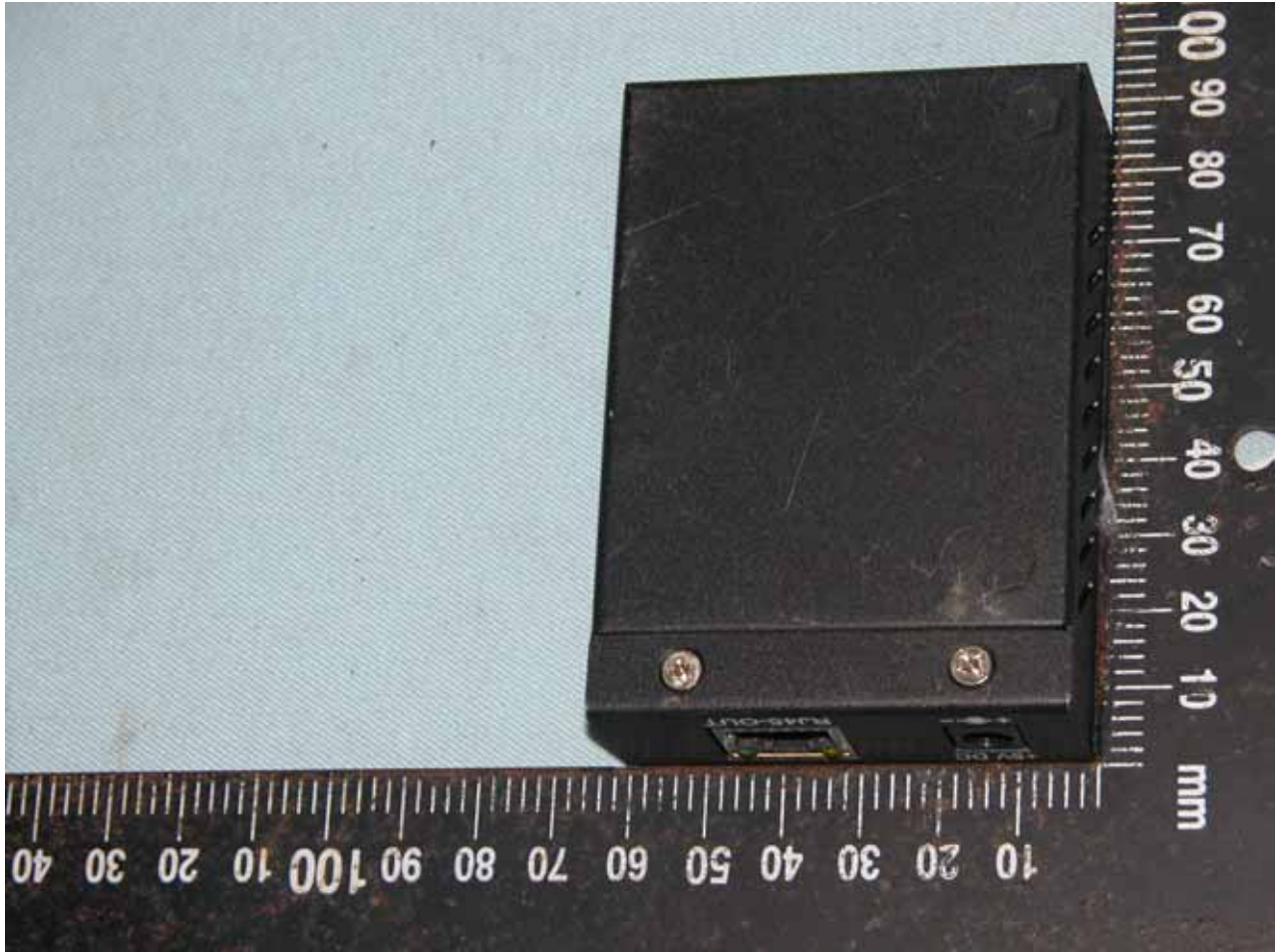
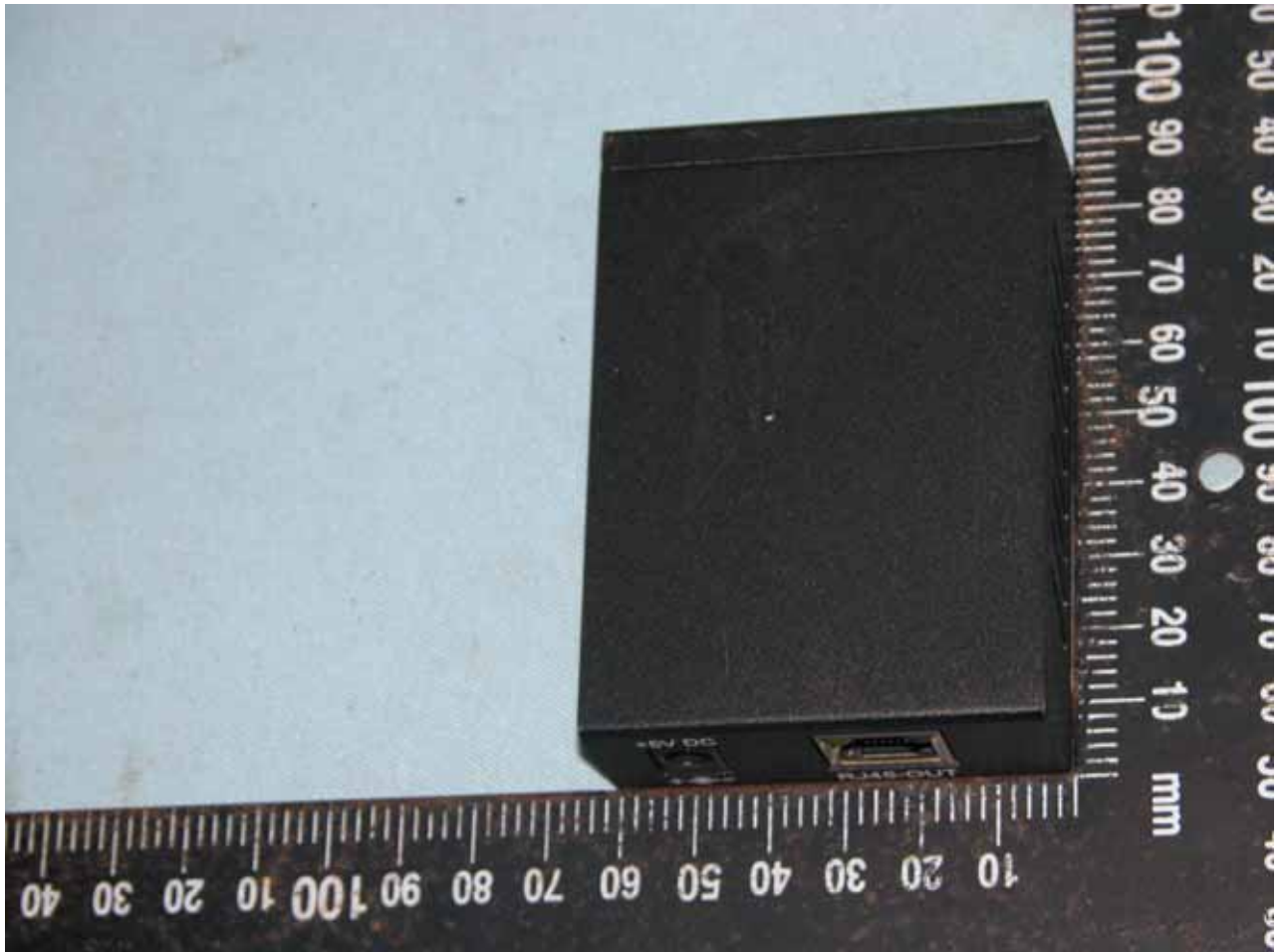

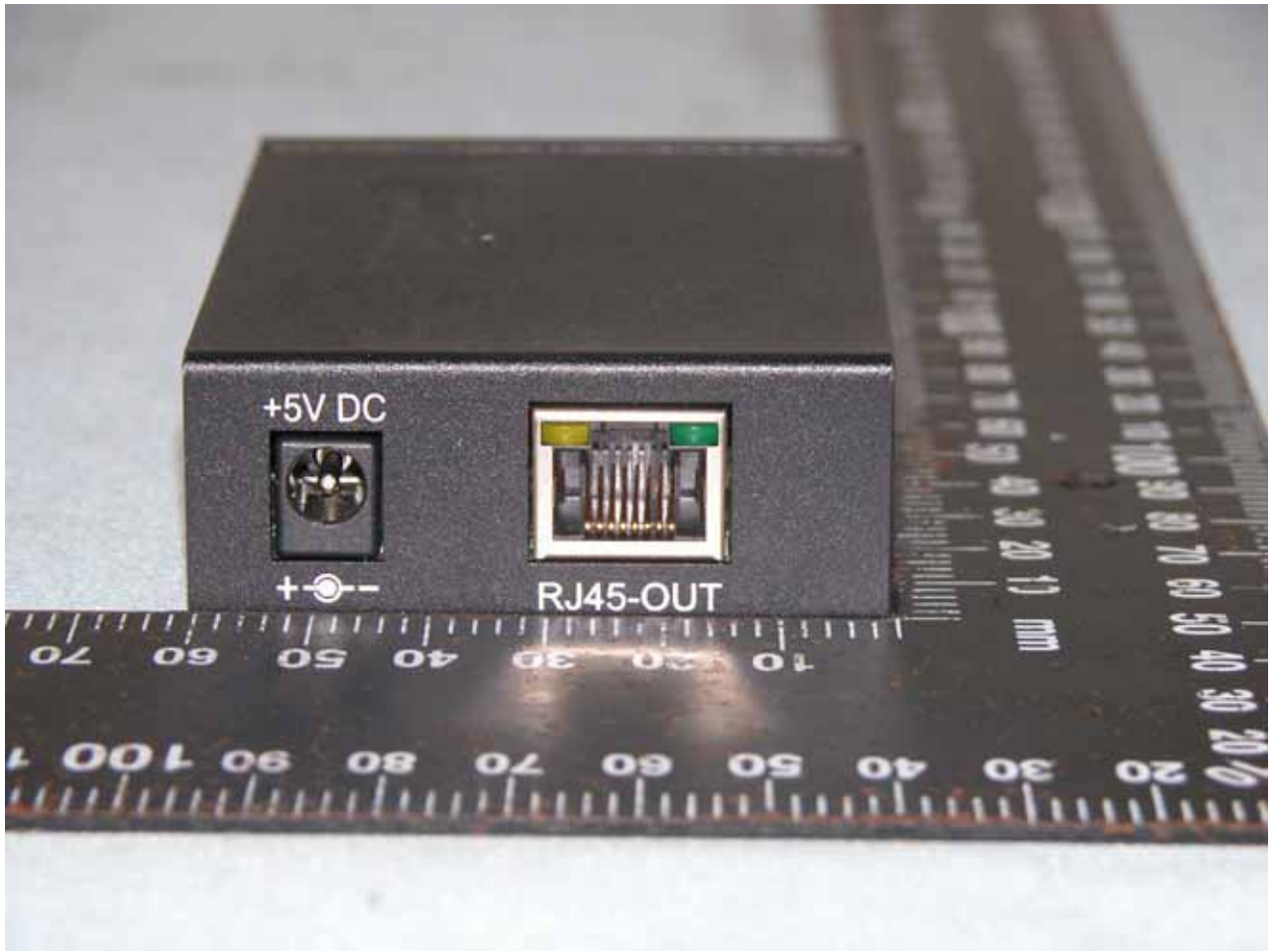

Adapter Photo

