



ADDRESS: No. 67-9, Shir Men Road, Tu Cheng City,  
Taipei Hsien, Taiwan

PHONE : 886-2-22608375 FAX : 886-2-22748013

E - mail : hometek@ms15.hinet.net

## CE TEST REPORT FOR

APPLICANT : Smart Home Engineering Corp.  
ADDRESS : 10F., No. 493, Chung-Cheng Rd.,  
Hsin-Tien City, Taipei 231, Taiwan, R. O. C.  
Receipt Date : 05/15/2007 Final Test Date: 05/18/2007  
EUT : 1 input 9 output video & audio CAT5  
distribution amplifier  
MODEL NO. : HE09XXX, CE09XXX, YE09XXX

### MEASUREMENT PROCEDURE USED

EN55022 CLASS B / EN61000-3-2 / EN61000-3-3 / EN55024 GIVEN IN  
EUROPEAN COUNCIL DIRECTIVE 2004/108/EC

This test result of this report applies to above tested sample only.

This test report shall not be reproducing in part without written approval of HomeTek Technology Inc.

PREPARED BY :

HomeTek Technology Inc.

No. 67-9, Shir Men Road, Tu Cheng City,

Taipei Hsien. Taiwan

Report # : EB6K034

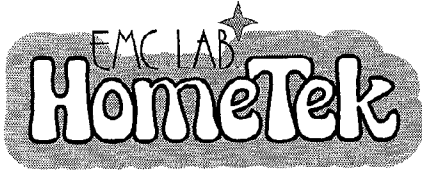

HomeTek Technology Inc.

ADDRESS: No. 67-9, Shir Men Road, Tu Cheng City,  
Taipei Hsien

PHONE : 886-2-22608375 FAX : 886-2-22748013

E - mail : hometek@ms15.hinet.net

## CERTIFICATE OF COMPLIANCE

EUT : 1 input 9 output video & audio CAT5  
distribution amplifier

MODEL NO. : HE09XXX, CE09XXX, YE09XXX

Receipt Date : 05/15/2007 Final Test Date: 05/18/2007

REPORT # : EB6K034

APPLICANT : Smart Home Engineering Corp.

ADDRESS : 10F., No. 493, Chung-Cheng Rd.,  
Hsin-Tien City, Taipei 231, Taiwan, R. O. C.

Measurement procedure used:

**EMI: EN 55022 Class B (1998) + A1 (2000) + A2 (2003),**

**EN 61000-3-2 (2000), EN 61000-3-3 (1995) + A1 (2001)**

**EMS: EN 55024 (1998) + A1 (2001) + A2 (2003):**

**IEC 61000-4-2 (2001), IEC 61000-4-3 (2002), IEC 61000-4-4 (2004), IEC 61000-4-5 (2001),**

**IEC 61000-4-6 (2003) + A1 (2004), IEC 61000-4-8 (2001), IEC 61000-4-11 (2004)**

We hereby show that:

The measurements shown in this test report were made in accordance with the procedures given in **EUROPEAN COUNCIL DIRECTIVE 2004/108/EC**, and the energy emitted by the equipment was found to be within the limits applicable. This product, which has been issued the test report listed as above in HomeTek Technology Inc., is based on single evaluation of one sample and confirmed to comply with the requirements of the above-mentioned EMC standard.

This test report is a duplicate of original one (report No. EB6E016, issued on 2007, 05, 30),  
applicant and model No. is modified.

APPROVED BY :  12/10/2007

ALAIN LIN / Assistant Manager

EB6K034



**TEST REPORT CERTIFICATION**

**EMC of electrical appliances**

Report reference No. : EB6K034  
Date of issue : DEC., 10, 2007  
Applicant : Smart Home Engineering Corp.  
Address : 10F., No. 493, Chung-Cheng Rd.,  
Hsin-Tien City, Taipei 231, Taiwan, R. O. C.  
Manufacturer : Smart Home Engineering Corp.  
Type of test object : 1 input 9 output video & audio CAT5 distribution amplifier  
Model/type reference : HE09XXX, CE09XXX, YE09XXX  
Rated Voltage : N/A  
EUT Voltage : N/A  
Test Result : Complied  
Testing laboratory : HomeTek Technology Inc.  
Address : No. 67-9, Shir Men Road, Tu Cheng City, Taipei Hsien,  
Taiwan, R. O. C.  
TEL / FAX : +886-2-22608375 / +886-2-22748013  
E-mail : hometek@ms15.hinet.net  
Standard : EN 55022 Class B (1998) + A1 (2000) + A2 (2003),  
EN 61000-3-2 (2000), EN 61000-3-3 (1995) + A1 (2001),  
EN 55024 (1998) + A1 (2001) + A2 (2003):  
IEC 61000-4-2 (2001), IEC 61000-4-3 (2002),  
IEC 61000-4-4 (2004), IEC 61000-4-5 (2001),  
IEC 61000-4-6 (2003) + A1 (2004), IEC 61000-4-8 (2001),  
IEC 61000-4-11 (2004)

Tested by (+ signature) :

Jason Lin / Engineer

Approved by (+ signature) :

Alain Lin / Assistant Manager



**TEST REPORT CERTIFICATION..... 1**

**TABLE OF CONTENTS..... 2**

**GENERAL INFORMATION..... 5**

**MODIFICATION LIST..... 6**

**CONDUCTED POWER LINE TEST ..... 7**

1 TEST INSTRUMENTS & FACILITIES..... 7

2 TEST PROCEDURE..... 7

3 TEST SETUP ..... 8

4 CONFIGURATION OF THE EUT ..... 10

5 EUT OPERATING CONDITION..... 15

6 LIMIT OF CONDUCTED POWER LINE EMISSION CLASS B..... 16

7 RESULT OF CONDUCTED POWER LINE TEST..... 16

8 CONDUCTED POWER LINE TEST DATA (PAGE 1)..... 17

9 CONDUCTED POWER LINE TEST DATA (PAGE 2)..... 18

10 CONDUCTED POWER LINE TEST DATA (PAGE 3)..... 19

11 CONDUCTED POWER LINE TEST DATA (PAGE 4)..... 20

12 CONDUCTED POWER LINE TEST DATA (PAGE 5)..... 21

13 CONDUCTED POWER LINE TEST DATA (PAGE 6)..... 22

**RADIATED EMISSION TEST..... 23**

1 TEST INSTRUMENTS & FACILITIES..... 23

2 TEST PROCEDURE..... 24

3 TEST SETUP ..... 24

4 CONFIGURATION OF THE EUT ..... 26

5 EUT OPERATING CONDITION..... 26

6 LIMIT OF RADIATED EMISSION CLASS B ..... 26

7 RESULT OF RADIATED EMISSION TEST..... 26

8 RADIATED EMISSION TEST DATA (PAGE 1)..... 27

9 RADIATED EMISSION TEST DATA (PAGE 2)..... 28

**HARMONICS TEST..... 29**

1 TEST INSTRUMENTS & FACILITIES..... 29

2 TEST PROCEDURE..... 29

3 TEST SETUP ..... 29

4 CONFIGURATION OF THE EUT ..... 29

5 OPERATION CONDITION OF EUT..... 29

6 TEST DATA & LIMIT..... 29

7 PHOTOS OF TEST CONFIGURATION PLEASE REFER TO APPENDIX A..... 29

8 HARMONICS TEST DATA (PAGE 1~2)..... 30

**VOLTAGE FLUCTUATIONS TEST ..... 32**

1 TEST INSTRUMENTS & FACILITIES..... 32

2 TEST PROCEDURE..... 32



3 TEST SETUP ..... 32

4 CONFIGURATION OF THE EUT ..... 32

5 OPERATION CONDITION OF EUT..... 32

6 TEST DATA & LIMIT ..... 32

7 PHOTOS OF TEST CONFIGURATION PLEASE REFER TO APPENDIX A..... 32

8 VOLTAGE FLUCTUATIONS TEST DATA (PAGE 1) ..... 33

**ELECTROSTATIC DISCHARGE IMMUNITY TEST (ESD) ..... 34**

1 TEST INSTRUMENTS & FACILITIES..... 34

2 TEST PROCEDURE..... 34

3 TEST SETUP ..... 34

4 CONFIGURATION OF THE EUT ..... 35

5 EUT OPERATION CONDITION..... 35

6 TEST CONDITION ..... 35

7 PERFORMANCE CRITERIA ..... 35

8 TEST RESULT ..... 36

**RADIO FREQUENCY ELECTROMAGNETIC FIELD IMMUNITY TEST (RF)..... 37**

1 TEST INSTRUMENTS & FACILITIES..... 37

2 TEST PROCEDURE..... 37

3 TEST SETUP ..... 38

4 CONFIGURATION OF THE EUT ..... 39

5 OPERATION CONDITION OF EUT..... 39

6 TEST CONDITION ..... 39

7 PERFORMANCE CRITERIA ..... 39

8 TEST RESULT ..... 40

**ELECTRICAL FAST TRANSIENT/BURST IMMUNITY TEST (EFT)..... 41**

1 TEST INSTRUMENTS & FACILITIES..... 41

2 TEST PROCEDURE..... 41

3 TEST SETUP ..... 41

4 CONFIGURATION OF THE EUT ..... 42

5 OPERATION CONDITION OF EUT..... 42

6 TEST CONDITION ..... 42

7 PERFORMANCE CRITERIA ..... 42

8 TEST RESULT ..... 43

**SURGE IMMUNITY TEST ..... 44**

1 TEST INSTRUMENTS & FACILITIES..... 44

2 TEST PROCEDURE..... 44

3 TEST SETUP ..... 44

4 TEST LEVELS..... 45

5 CONFIGURATION OF THE EUT ..... 45

6 EUT OPERATION CONDITION..... 45

7 CONDITIONS DURING TESTING..... 45



8 PERFORMANCE CRITERIA ..... 46

9 TEST RESULT ..... 46

**IMMUNITY TEST TO CS CONDUCTED DISTURBANCE ..... 47**

1 TEST INSTRUMENTS & FACILITIES..... 47

2 TEST PROCEDURE..... 47

3 TEST SETUP ..... 48

4 TEST LEVELS..... 49

5 CONFIGURATION OF THE EUT ..... 49

6 EUT OPERATION CONDITION..... 49

7 CONDITIONS DURING TESTING..... 49

8 PERFORMANCE CRITERIA ..... 50

9 TEST RESULT ..... 50

**POWER FREQUENCY MAGNETIC FIELD IMMUNITY TEST ..... 51**

1 TEST INSTRUMENTS & FACILITIES..... 51

2 TEST STANDARD..... 51

3 TEST SETUP ..... 51

4 TEST LEVELS..... 52

5 CONFIGURATION OF THE EUT ..... 52

6 OPERATION CONDITION OF EUT..... 52

7 CONDITIONS DURING TESTING..... 52

8 PERFORMANCE CRITERIA ..... 52

9 TEST RESULTS ..... 53

**VOLTAGE DIPS, SHORT INTERRUPTIONS IMMUNITY TEST ..... 54**

1 TEST INSTRUMENTS & FACILITIES..... 54

2 TEST PROCEDURE..... 54

3 TEST SETUP ..... 54

4 TEST LEVELS..... 55

5 CONFIGURATION OF THE EUT ..... 55

6 EUT OPERATION CONDITION..... 55

7 CONDITIONS DURING TESTING..... 55

8 PERFORMANCE CRITERIA ..... 56

9 TEST RESULT ..... 56

**APPENDIX A**

PHOTOS OF TEST CONFIGURATION

**APPENDIX B**

PHOTOS OF EUT

**GENERAL INFORMATION**

- 1 APPLICANT : Smart Home Engineering Corp.
- 2 ADDRESS : 10F., No. 493, Chung-Cheng Rd.,  
Hsin-Tien City, Taipei 231, Taiwan, R. O. C.
- 3 MANUFACTURER : Smart Home Engineering Corp.
- 4 ADDRESS : 10F., No. 493, Chung-Cheng Rd.,  
Hsin-Tien City, Taipei 231, Taiwan, R. O. C.
- 5 DESCRIPTION OF EUT :
- EUT : 1 input 9 output video & audio CAT5  
distribution amplifier
- Model : HE09XXX, CE09XXX, YE09XXX
- Serial # : N/A

5.1 The difference among series of models HE09XXX, CE09XXX and YE09XXX are different in OEM manufacture and other as shown below:

- (1) The first and second “X” represents different system input.
- (2) The third “X” represent different accessory.

The PCB layout is similar. The worst case of EMC test data were shown in this test report.

- 6 FEATURES OF EUT :

**Please refer to user manual or product specification.**

## **MODIFICATION LIST**

**THE FOLLOWING ACCESSORIES WERE ADDED TO THE EUT DURING TESTING :**

**NO MODIFICATION BY HOMETEK TECHNOLOGY INC.**

## CONDUCTED POWER LINE TEST

### 1 TEST INSTRUMENTS & FACILITIES

The following test Instruments was used during the conducted test :

Item	Instruments/ Facilities	Specification	Manufacturer	Model #	Date Of Cal.
1	EMI Receiver	9KHz ~ 30MHz	ROHDE & SCHWARZ	ESHS 30 844827/007	FEB/2007
2	LISN (for EUT)	50Ω/50uH/100A 150KHz ~ 30MHz	SCHWARZ BECK	NNLK 8121 8121370	OCT/2006
3	LISN (for Support Unit)	50Ω/50uH/10A 9KHz ~ 30MHz	ROHDE & SCHWARZ	ESH3-Z5 846128/007	MAR/2007
4	Terminator	50Ω	N/A	N/A	NOV/2006
5	Attenuation	50Ω/10dB	Mini-Circuit	NAT-10 AT-002	JUL/2006
6	Cable	5.4m	SUHNER	RG-223 CON2-002	AUG/2006
7	ESXS-K1 (software)	Version 2.03b 9KHz ~ 30MHz	ROHDE & SCHWARZ	1082.9678.02 840.913/246	N/A

Note : Items 1 ~ 6 were calibrated within period of 1 year.

### 2 TEST PROCEDURE

- 2.1 The EUT was tested according to **EN55022 Class B**.
- 2.2 The EUT was placed 0.4 meter from the conducting wall of shielding room and kept at least 0.8 meter from any other grounded conducting surface.
- 2.3 The frequency range form 0.15 MHz to 30 MHz was investigated.
- 2.4 The LISN used was 50 Ohm / 50 uHenry as specified by **EN55022**.
- 2.5 All the support peripherals are connect to the other LISN.
- 2.6 Cables and peripherals were moved to find the maximum emission levels for each frequency.

### 3 TEST SETUP

#### 3.1 Typical : Setup Of Conducted Test

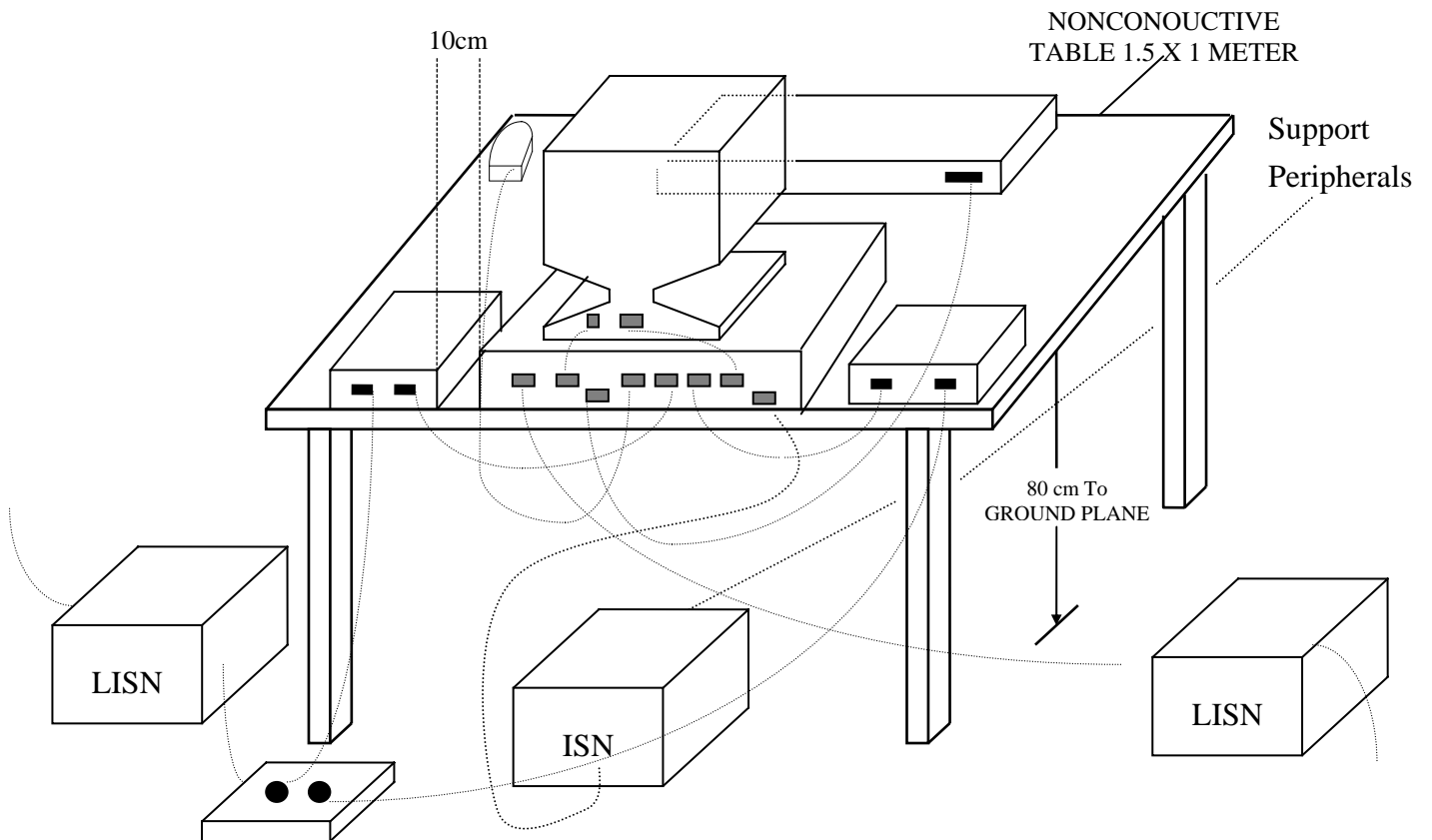

(Details for setup configuration, please refer to appendix A.)

### 3.2 Block Diagram Of Conducted Test

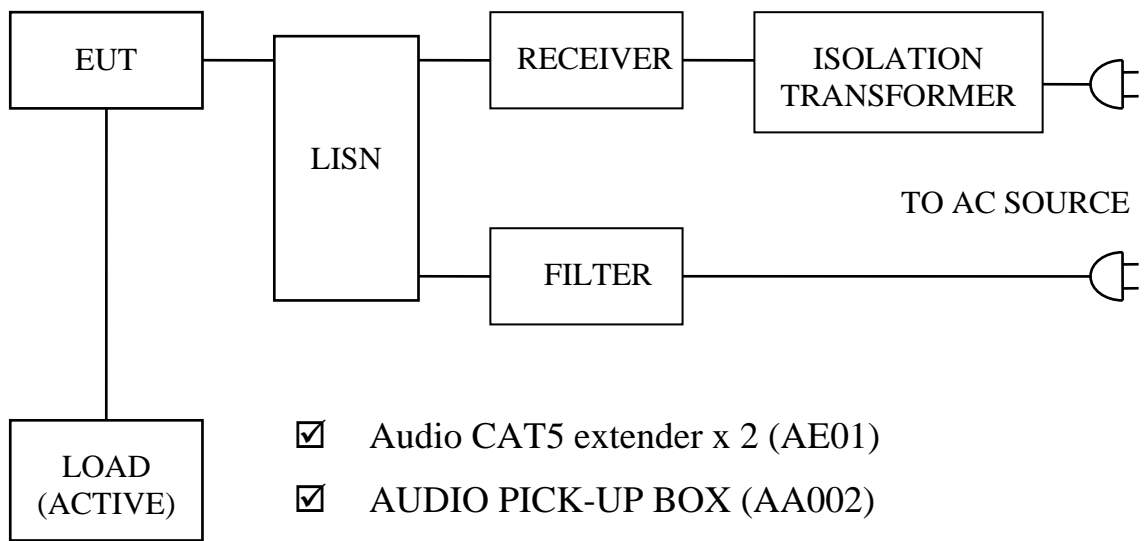

- Audio CAT5 extender x 2 (AE01)
- AUDIO PICK-UP BOX (AA002)
- Twisted Pair 1 input to 2 Output Video Distributor (TDA102)
- Wall Plate Audio & Video CAT5 Extender (CW01A)
- Video & Audio Transceiver (TTP111AV)
- CCD Camera
- TV
- Power Adapter

#### 4 CONFIGURATION OF THE EUT

The EUT was configured according to **EN55022**. All I/O ports were connected to the appropriate peripherals. All peripherals and cables are listed below (including internal device) :

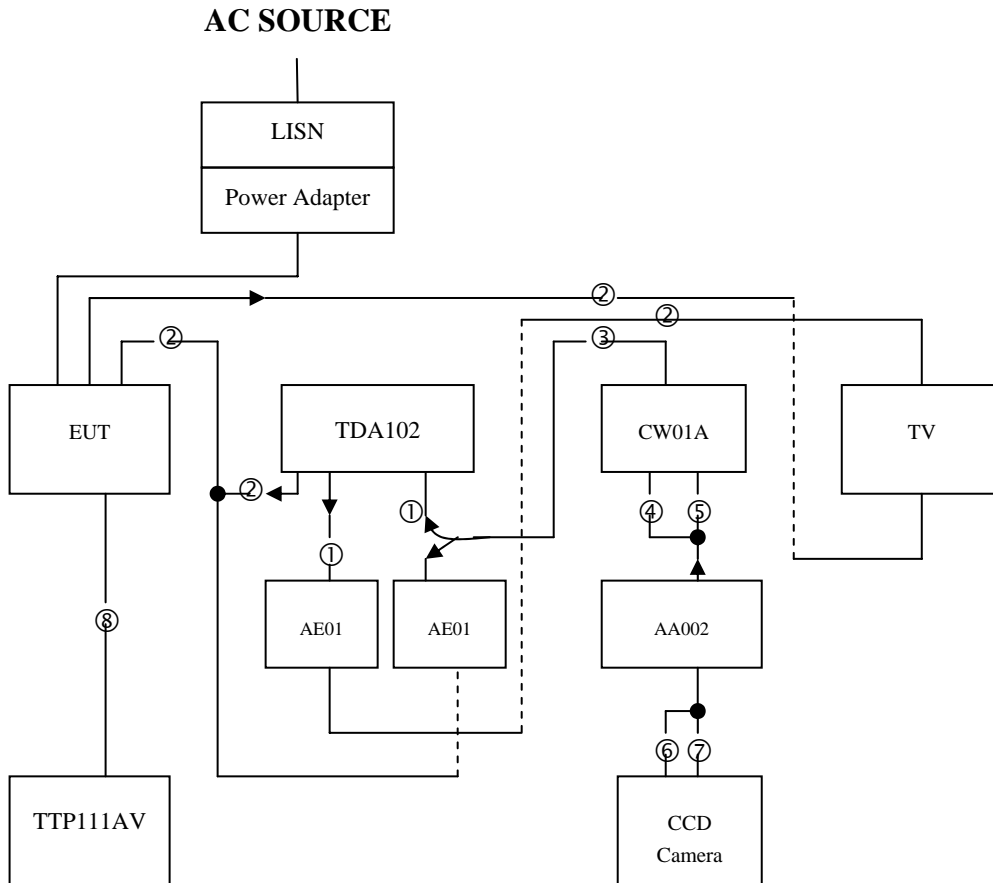

- ① Data Cable
- ② AV Cable
- ③ RJ-45 Cable
- ④ Audio Out Cable
- ⑤ Video Out Cable
- ⑥ Video In Cable
- ⑦ Power Cable
- ⑧ RJ-45 Cable x 9

Figure 1



#### 4.1 EUT

EUT Type : Proto Type Engineer Type Mass Production  
Condition when received : Good Damage : \_\_\_\_\_  
Device : 1 input 9 output video & audio CAT5 distribution amplifier  
Applicant : Smart Home Engineering Corp.  
Manufacturer : Smart Home Engineering Corp.  
Model Number : HE09XXX, CE09XXX, YE09XXX  
Serial Number : N/A  
FCC ID : N/A  
Audio In Port x 2 : Metal Type Connector  
Video In Port : Metal Type Connector  
Audio Out Port x 2 : Metal Type Connector  
Video Out Port : Metal Type Connector  
RJ-45 Port x 9 : Plastic Type Connector  
Power Cord (AC) : 2 pin  
Power Cord (DC) : Un-Shielded, 1.8 m, 2 pin  
Power Supply Type : Linear Adapter

#### 4.2 PERIPHERALS

##### AUDIO PICK-UP BOX

Manufacturer : Smart Home Engineering Corp.  
Model Number : AA002  
Serial Number : N/A  
FCC ID : N/A  
Data Cable 1 : Un-Shielded, 0.5 m, Connected to the AV Out port  
Data Cable 2 : Un-Shielded, 0.3 m, Connected to the Video port  
Data Cable 3 : Un-Shielded, 0.5 m, Connected to the Power Output port



## HomeTek Technology Inc.

- Power Cord : N/A
- Audio CAT5 extender x 2
- Manufacturer : Smart Home Engineering Corp.
- Model Number : AE01
- Serial Number : N/A
- FCC ID : N/A
- Data Cable 1 : Un-Shielded, 0.1 m, Connected to the Video In port
- Data Cable 2 : Un-Shielded, 0.1 m, Connected to the Video Out port
- Data Cable 3 : Shielded, 1.6 m, Connected to the AV In port
- Data Cable 4 : Shielded, 1.6 m, Connected to the AV Out port
- Power Cord : N/A
- 
- Twisted Pair 1 input to 2 Output Video Distributor
- Manufacturer : SMART CABLING & TRANSMISSION CORP.
- Model Number : TDA102
- Serial Number : N/A
- FCC ID : N/A
- Data Cable 1 : Un-Shielded, 0.1 m, Connected to the Video In port
- Data Cable 2 : Un-Shielded, 0.1 m, Connected to the Video Out port
- Data Cable 3 : Shielded, 1.6 m, Connected to the Video Out port
- Power Cord & Adaptor : Un-Shielded, 1.8 m
- 
- Wall Plate Audio & Video CAT5 Extender
- Manufacturer : Smart Home Engineering Corp.
- Model Number : CW01A
- Serial Number : N/A
- FCC ID : N/A
- Data Cable 1 x 2 : Un-Shielded, 0.5 m, Connected to the AV Out port
- Data Cable 2 : Un-Shielded, 0.3 m, Connected to the RJ-45 port



HomeTek Technology Inc.

Power Cord (DC) : N/A

Video & Audio Transceiver

Manufacturer : SMART CABLING & TRANSMISSION CORP.

Model Number : TTP111AV

Serial Number : N/A

FCC ID : N/A

Data Cable x 9 : Un-Shielded, 10 m, Connected to the RJ-45 port

Power Cord (DC) : N/A

CCD Camera

Manufacturer : Comedar

Model Number : CM-930

Serial Number : N/A

FCC ID : N/A

Data Cable 1 : Un-Shielded, 0.3 m, Connected to the Video port

Data Cable 2 : Un-Shielded, 0.5 m, Connected to the Power Output port

Power Cord : N/A

TV

Manufacturer : TCL

Model Number : 1419A

Serial Number : 010019502035F0039

FCC ID : N/A

Data Cable 1 : Shielded, 1.2 m, Connected to the AV Out port

Data Cable 2 : Shielded, 1.6 m, Connected to the AV Out port

Power Cord (DC) : Un-Shielded, 1.8 m



Power Adapter

Manufacturer : YUH AN

Model Number : ADP2011-2

Serial Number : N/A

FCC ID : N/A

Data Cable : N/A

Power Cord (DC) : Un-Shielded, 1.8 m

4.3 REMARK : N/A

## 5 EUT OPERATING CONDITION

5.1 The frequency of the EUT is none.

5.2 Configure the EUT according to the **EN 55022 Class B**.

5.3

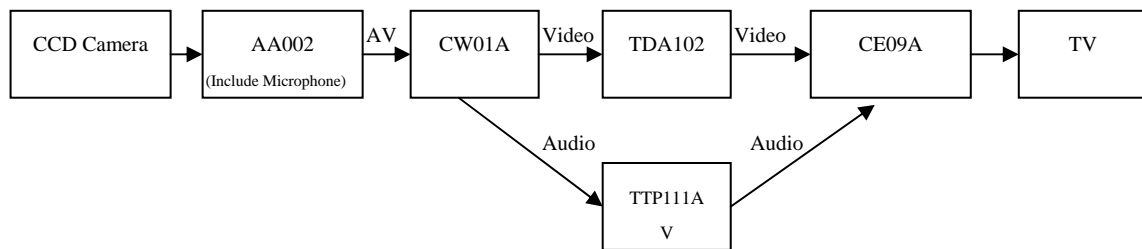

5.4 CCD camera & AA002 send audio and video signals to CW01A, TTP111AV, TDA102, CE09A, and CW01A, TTP111AV, TDA102, CE09A change audio and video signals.

5.5 Then has changed audio and video signals send to TV display.

5.6 Measure the maximum emission noise.

5.7 **The photos of conducted test configuration, please refer to appendix A.**

## 6 LIMIT OF CONDUCTED POWER LINE EMISSION CLASS B

Frequency Range	Quasi Peak	Average
0.15 ~ 0.5 MHz	66 - 56 dBuV	56 - 46 dBuV
0.5 ~ 5 MHz	56 dBuV	46 dBuV
5 ~ 30 MHz	60 dBuV	50 dBuV

## 7 RESULT OF CONDUCTED POWER LINE TEST

- 7.1 The frequency range from 0.15 MHz to 30 MHz was investigated. All readings are quasi-peak values and average.
- 7.2 IF bandwidth : 9 kHz, Meas Time : 1 sec.
- 7.3 Temperature : 26 °C, Humidity : 60 % RH.
- 7.4 Deviations from the test standards and rules : None.
- 7.5 The conducted test result were gained by following procedures :  
 Level = Reading Level + Insertion Loss of LISN + Cable Loss  
 (All calculation were done by ESHS30 EMI test receiver.)
- 7.6 Result : **PASSED**

## 8 CONDUCTED POWER LINE TEST DATA (PAGE 1)

HomeTek EMC LAB. TEL :886-2-22608375

15 May 2007 14:46

### CONDUCTED EMISSIONS

EUT: 1 input 9 output video & audio CAT5 distribution amplifier  
 Manuf: 6E016  
 Op Cond: LINE 1  
 Operator: JASON  
 Test Spec: FOR EN55022 CLASS B  
 Comment: 230V/50Hz  
 CE09A

Result File:

Prescan Measurement: Detectors: X PK / + AV  
 Meas Time: see scan settings  
 Subranges: 16  
 Acc Margin: 55 dB

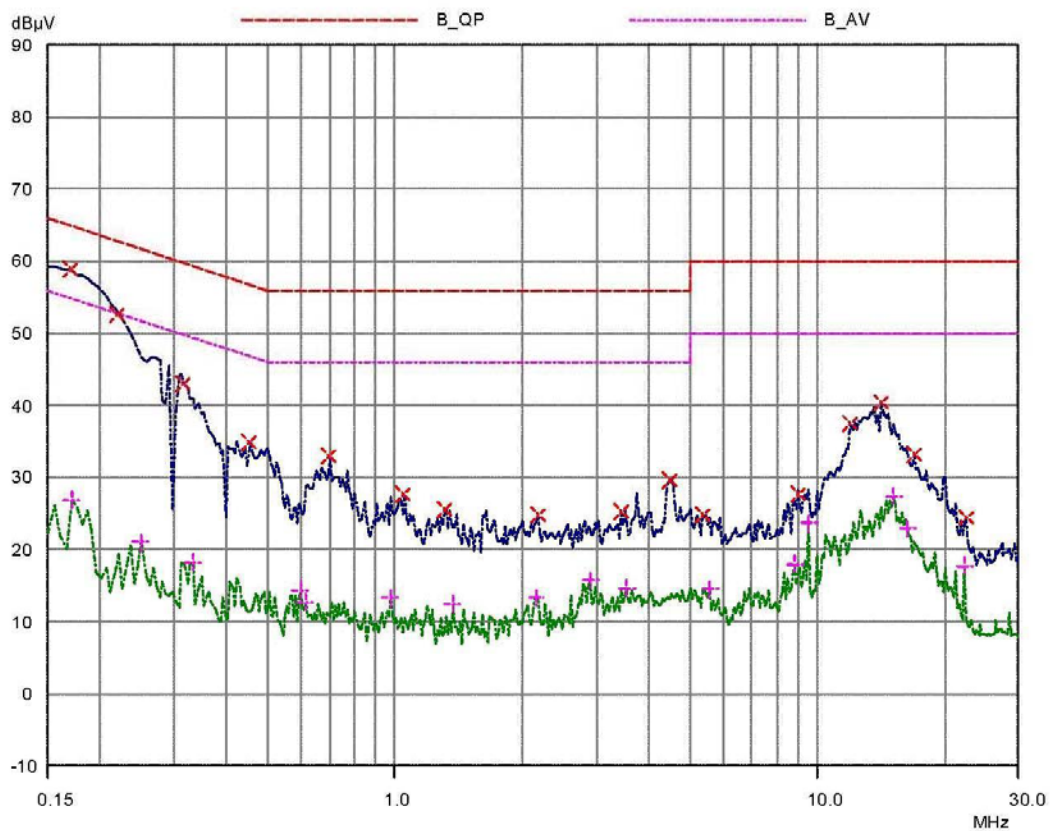



### 9 CONDUCTED POWER LINE TEST DATA (PAGE 2)

HomeTek EMC LAB. TEL :886-2-22608375

15 May 2007 14:46

#### CONDUCTED EMISSIONS

EUT: 1 input 9 output video & audio CAT5 distribution amplifier  
 Manuf: 6E016  
 Op Cond: LINE 1  
 Operator: JASON  
 Test Spec: FOR EN55022 CLASS B  
 Comment: 230V/50Hz  
 CE09A

Result File:

Prescan Measurement: Detectors: X PK / + AV  
 Meas Time: see scan settings  
 Subranges: 16  
 Acc Margin: 55 dB

#### Peak Search Results

Frequency MHz	PK Level dBµV	PK Limit dBµV	PK Delta dB
0.17	58.81	64.96	6.15
0.22	52.69	62.82	10.13
0.315	42.97	59.84	16.87
0.45	34.92	56.88	21.96
0.7	32.89	56.00	23.11
1.05	27.62	56.00	28.38
1.31	25.62	56.00	30.38
2.17	24.85	56.00	31.15
3.42	25.31	56.00	30.69
4.46	29.69	56.00	26.31
5.33	24.92	60.00	35.08
8.94	27.59	60.00	32.41
11.97	37.43	60.00	22.57
14.18	40.52	60.00	19.48
16.9	33.25	60.00	26.75
22.5	24.44	60.00	35.56

Frequency MHz	AV Level dBµV	AV Limit dBµV	AV Delta dB
0.17	26.91	54.96	28.05
0.25	21.04	51.76	30.72
0.33	18.21	49.45	31.24
0.595	14.37	46.00	31.63
0.61	12.69	46.00	33.31
0.97	13.27	46.00	32.73
1.36	12.45	46.00	33.55
2.16	13.29	46.00	32.71
2.89	15.78	46.00	30.22
3.53	14.69	46.00	31.31
5.53	14.49	50.00	35.51
8.8	18.06	50.00	31.94
9.47	23.63	50.00	26.37
15.14	27.36	50.00	22.64
16.29	22.98	50.00	27.02
22.25	17.82	50.00	32.18

\* limit exceeded

### 10 CONDUCTED POWER LINE TEST DATA (PAGE 3)

HomeTek EMC LAB. TEL :886-2-22608375

15 May 2007 14:50

**CONDUCTED EMISSIONS**

EUT: 1 input 9 output video & audio CAT5 distribution amplifier  
 Manuf: 6E016  
 Op Cond: LINE 2  
 Operator: JASON  
 Test Spec: FOR EN55022 CLASS B  
 Comment: 230V/50Hz  
 CE09A

Result File:

Prescan Measurement: Detectors: X PK / + AV  
 Meas Time: see scan settings  
 Subranges: 16  
 Acc Margin: 55 dB

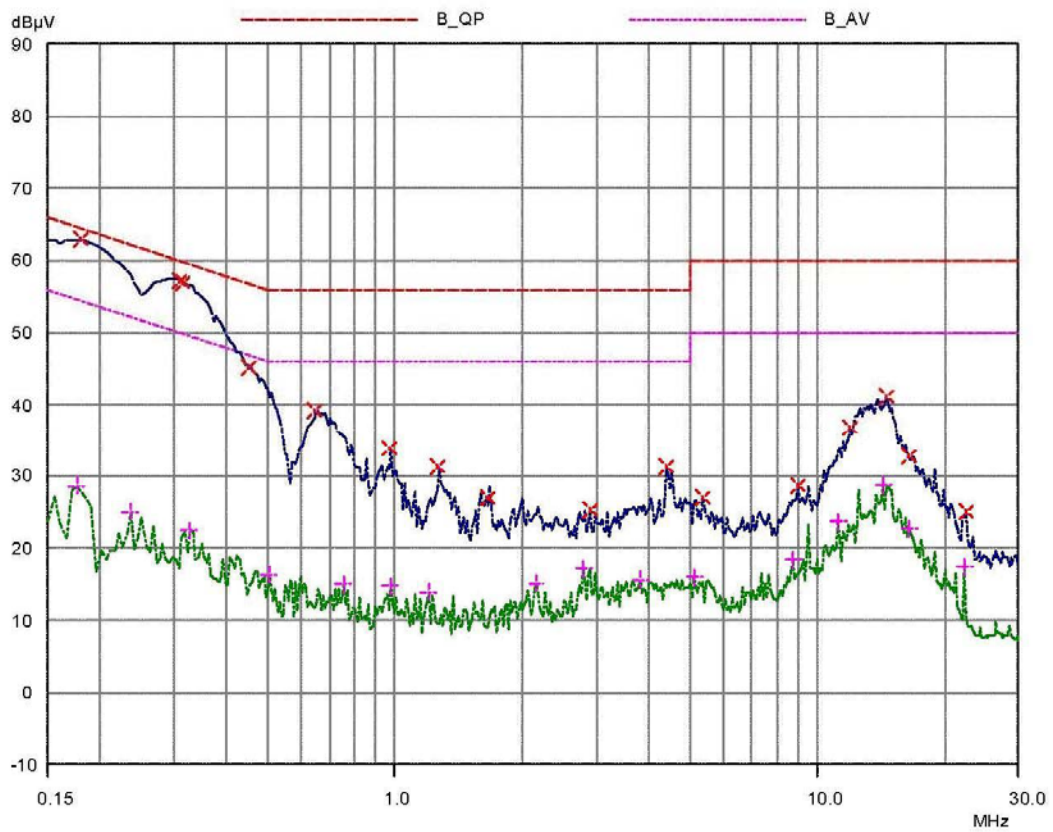



# 11 CONDUCTED POWER LINE TEST DATA (PAGE 4)

HomeTek EMC LAB. TEL :886-2-22608375

15 May 2007 14:50

## CONDUCTED EMISSIONS

EUT: 1 input 9 output video & audio CAT5 distribution amplifier  
 Manuf: 6E016  
 Op Cond: LINE 2  
 Operator: JASON  
 Test Spec: FOR EN55022 CLASS B  
 Comment: 230V/50Hz  
 CE09A

Result File:

Prescan Measurement: Detectors: X PK / + AV  
 Meas Time: see scan settings  
 Subranges: 16  
 Acc Margin: 55 dB

### Peak Search Results

Frequency MHz	PK Level dBµV	PK Limit dBµV	PK Delta dB
0.18	62.91	64.49	1.58
0.31	57.35	59.97	2.62
0.315	56.99	59.84	2.85
0.45	45.24	56.88	11.64
0.65	39.21	56.00	16.79
0.97	33.81	56.00	22.19
1.27	31.26	56.00	24.74
1.67	26.94	56.00	29.06
2.89	25.39	56.00	30.61
4.39	31.23	56.00	24.77
5.33	26.99	60.00	33.01
8.95	28.69	60.00	31.31
11.92	36.72	60.00	23.28
14.48	41.11	60.00	18.89
16.51	32.68	60.00	27.32
22.42	24.93	60.00	35.07

Frequency MHz	AV Level dBµV	AV Limit dBµV	AV Delta dB
0.175	28.57	54.72	26.15
0.235	24.98	52.27	27.29
0.325	22.44	49.58	27.14
0.5	16.37	46.00	29.63
0.75	15.05	46.00	30.95
0.97	14.78	46.00	31.22
1.2	13.96	46.00	32.04
2.16	15.16	46.00	30.84
2.78	17.15	46.00	28.85
3.78	15.59	46.00	30.41
5.08	15.95	50.00	34.05
8.7	18.34	50.00	31.66
11.11	23.67	50.00	26.33
14.28	28.72	50.00	21.28
16.39	22.73	50.00	27.27
22.25	17.36	50.00	32.64

\* limit exceeded



## 12 CONDUCTED POWER LINE TEST DATA (PAGE 5)

HomeTek EMC LAB. TEL :886-2-22608375

15 May 2007 14:52

### CONDUCTED EMISSIONS

EUT: 1 input 9 output video & audio CAT5 distribution amplifier  
Manuf: 6E016  
Op Cond: LINE 2  
Operator: JASON  
Test Spec: FOR EN55022 CLASS B  
Comment: 230V/50Hz  
CE09A

Result File:

Prescan Measurement:    Detector:    X QP  
                                 Meas Time:    see scan settings  
                                 Subranges:    16  
                                 Acc Margin:    55 dB

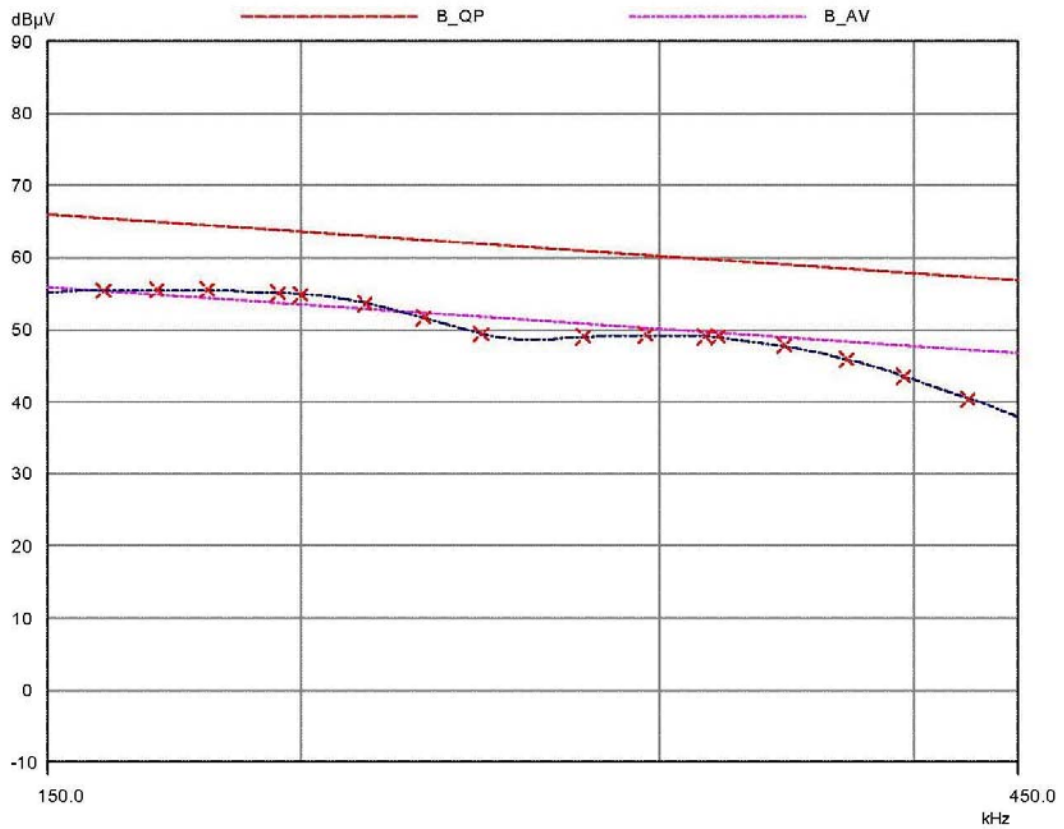



### 13 CONDUCTED POWER LINE TEST DATA (PAGE 6)

HomeTek EMC LAB. TEL :886-2-22608375

15 May 2007 14:52

#### CONDUCTED EMISSIONS

EUT: 1 input 9 output video & audio CAT5 distribution amplifier  
 Manuf: 6E016  
 Op Cond: LINE 2  
 Operator: JASON  
 Test Spec: FOR EN55022 CLASS B  
 Comment: 230V/50Hz  
 CE09A

Result File:

Prescan Measurement:    Detector:    X QP  
                                  Meas Time:    see scan settings  
                                  Subranges:    16  
                                  Acc Margin:    55 dB

#### Peak Search Results

Frequency kHz	QP Level dBµV	QP Limit dBµV	QP Delta dB
160.0	55.44	65.46	10.02
170.0	55.53	64.96	9.43
180.0	55.50	64.49	8.99
195.0	55.12	63.82	8.70
200.0	54.93	63.61	8.68
215.0	53.75	63.01	9.26
230.0	51.68	62.45	10.77
245.0	49.43	61.92	12.49
275.0	49.01	60.97	11.96
295.0	49.25	60.38	11.13
315.0	49.12	59.84	10.72
320.0	48.98	59.71	10.73
345.0	47.77	59.08	11.31
370.0	45.94	58.50	12.56
395.0	43.53	57.96	14.43
425.0	40.48	57.35	16.87

\* limit exceeded

## RADIATED EMISSION TEST

### 1 TEST INSTRUMENTS & FACILITIES

The following test Instruments was used during the radiated emission test :

Item	Instruments /facilities	Specification	Manufacturer	Model # / S/N#	Date of Cal.
1	OPEN AREA TEST SITE	<input checked="" type="checkbox"/> OATS 3			JUL/2006
2	EMI TEST RECEIVER	20Hz ~ 26.5GHz	ROHDE & SCHWARZ	ESMI 845442/006	FEB/2007
3	PRE-AMPLIFIER	9KHz ~ 3000MHz	ADVANTEST	BB525C 90081001	OCT/2006
4	ANTENNA (BI-LOG)	25MHz ~ 2GHz	SCHAFFNER	CBL6112B S/N : 2614	JUN/2006
5	Attenuation	50Ω/6dB	JYE BAO	FAT-N (M-F) 001	JUL/2006
6	Ferrite Clamp	30 ~ 1000MHz	ADT	FC18 910030	DEC/2006
7	Ferrite Clamp	30 ~ 1000MHz	HomeTek	HFC 001	DEC/2006
8	Cable	10m	SUHNER	RG214/U OS3-003	DEC/2006
9	Cable	14m	BELDEN	9913 OS3-001	DEC/2006
10	EMI 32 (software)	N/A	AUDIX	19991013-0923	N/A

Note : Items 1 ~ 9 were calibrated within period of 1 year.

## 2 TEST PROCEDURE

- 2.1 The EUT was test according to **EN55022**.
- 2.2 The radiated test was performed at HomeTek Lab's Open Site 3.
- 2.3 The frequency range from 30 MHz to 1 GHz, the measurement were made at 10 meters, with a BI-log antenna.

## 3 TEST SETUP

### 3.1 TEST SETUP OF OPEN SITE.

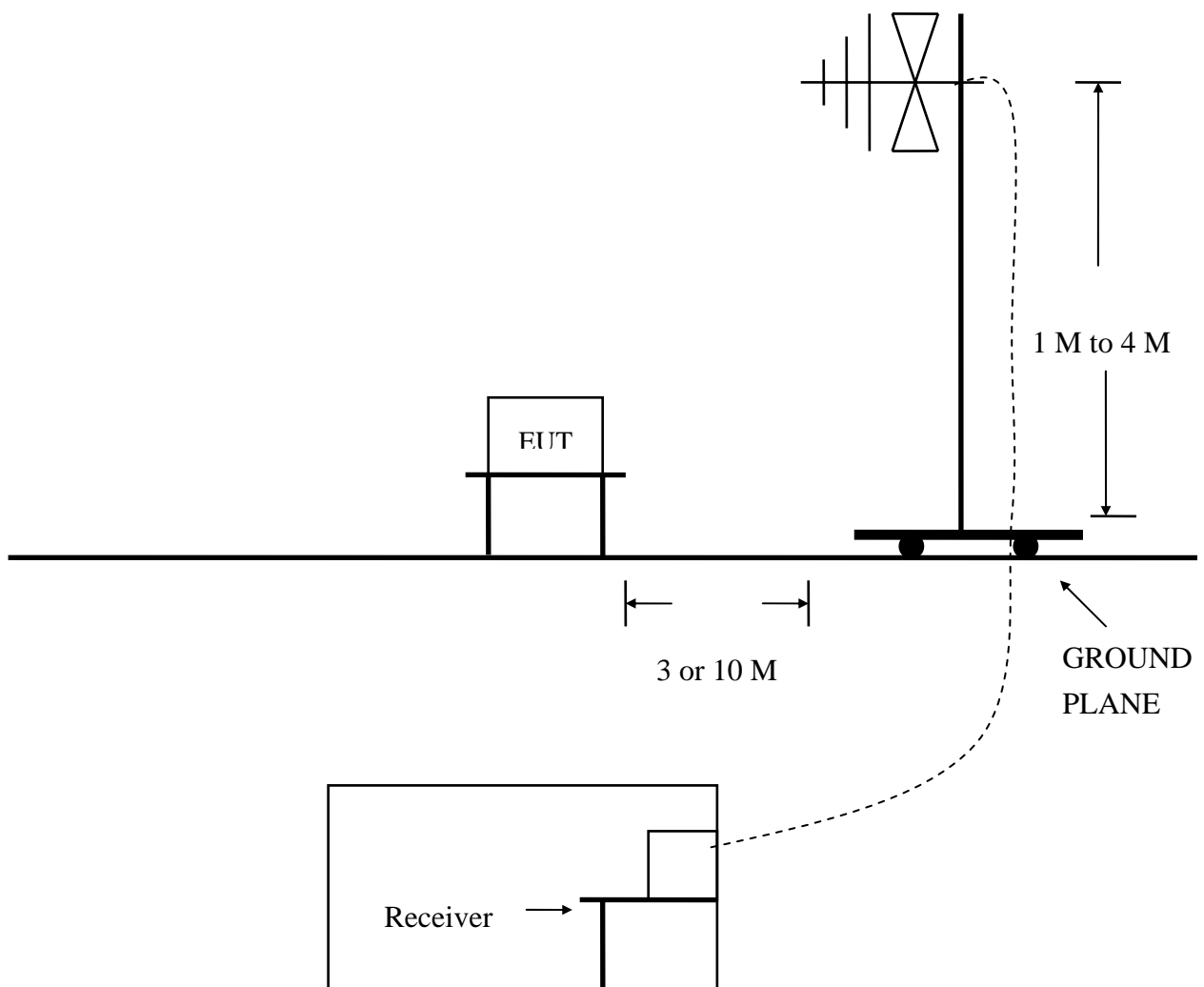

(Details for setup configuration, please refer to appendix A.)

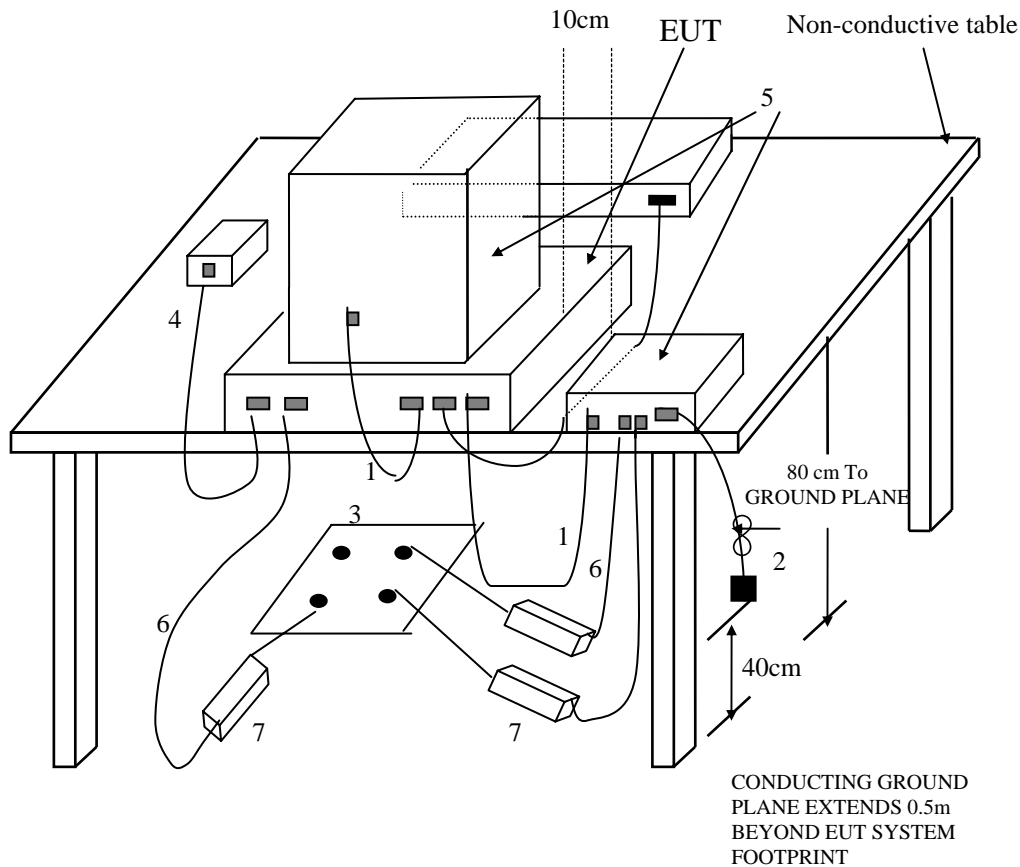

(Details for setup configuration, please refer to appendix A.)

#### LEGEND:

- 1.If cables, which hang closer than 40 cm to the horizontal metal ground plane cannot be shortened to the appropriate length, the excess shall be folded back and forth forming a bundle 30 cm to 40 cm long.
- 2.The end of I/O signal cables which are not connected to a peripheral may be terminated, if required for proper operation using correct terminating impedance.
- 3.Mains junction box(es) shall be flush with, and bonded directly to, the metal ground plane.  
NOTE if used, the AMN shall be installed under the horizontal metal ground plane.
- 4.Cables of hand-operated devices such as keyboards, mice, etc. shall be placed as for normal usage.
- 5.Peripherals shall be placed at a distance of 10 cm from each other and from the controller, except for the monitor which, if for an acceptable installation practice, shall be placed directly on top of the controller.
- 6.Mains cables, telephone lines or other connections to auxiliary equipment located outside the test area shall drape to the floor, be fitted with ferrite clamps or ferrite tubes placed on the floor at the point where the cable reaches the floor and then routed to the place where they leave the turntable. No extension cords shall be used to mains receptacle.
- 7.Ferrite clamps or ferrite tubes with similar characteristics (as defined in 10.4). No more than one cable per clamp.

### Test Configuration

#### Tabletop Equipment Radiated Measurement

4 CONFIGURATION OF THE EUT

Same as “Conducted Power Line test”, section 4

5 EUT OPERATING CONDITION

5.1 Same as “Conducted Power Line test”, section 5

5.2 The radiated emission in the frequency range from 30 MHz - 1000 MHz was test in a horizontal and vertical polarization at HomeTek Lab’s open site 3.

**5.3 The photos of radiated test configuration, please refer to appendix A.**

6 LIMIT OF RADIATED EMISSION CLASS B

Frequency (MHz)	Measurement Distance	Limit (dBuV/m)
30 - 230	10 (M)	30
230 - 1000	10 (M)	37

7 RESULT OF RADIATED EMISSION TEST

7.1 The frequency range from 30 MHz to 1 GHz was investigated.

7.2 All readings below or equal 1 GHz are quasi-peak or peak values with resolution bandwidth of 120 KHz.

7.3 The measurements were made at 10 meters of HomeTek Lab’s open site 3.

7.4 Temperature : 29 °C, Humidity : 58 % RH.

7.5 Deviation form the test standards and rules : None.

7.6 The radiated emission result were gained by the following method :

$$\text{Level} = \text{Reading Level} + \text{Probe Factor (Antenna Factor)} + \text{Cable Loss} - \text{Preamp Factor}$$

$$\text{Over Limit} = \text{Level} - \text{Limit Line}$$

7.7 Result : **PASSED**

8 RADIATED EMISSION TEST DATA (PAGE 1)



HomeTek Technology Inc.

No 67-9, Shi-Men Rd., Tu-Chen City,  
 Taipei County, Taiwan R.O.C.  
 Tel: 02-22608375  
 Fax: 02-22748013

Data#: 5 File#: 6e016.EMI

Date: 2007-05-16 Time: 17:39:15

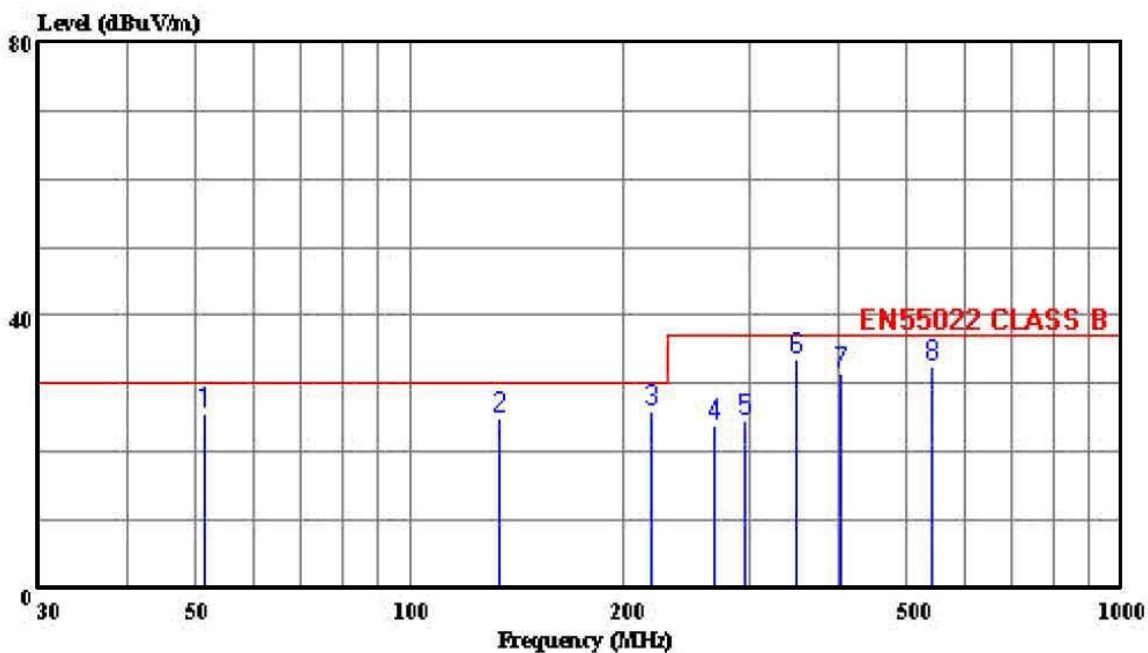

Trace:

Ref Trace:

Condition: EN55022 CLASS B 10m CHASE 2614 060506 HORIZONTAL  
 out : 1 input 9 output video & audio CAT5  
 power: 230V/50Hz  
 memo : CE09A

Page: 1

	Limit	Over	ReadAntenna	Cable	Preamp			
Freq	Level	Line	Level	Loss	Factor	Remark		
MHz	dBuV/m	dBuV/m	dB	dB	dB/m	dB	dB	
1	51.348	25.66	30.00	-4.34	42.48	8.37	0.78	25.97 Peak
2	133.396	24.80	30.00	-5.20	37.44	11.46	1.73	25.83 Peak
3	218.642	25.93	30.00	-4.07	40.25	9.10	2.25	25.67 Peak
4	266.940	23.72	37.00	-13.28	33.72	12.99	2.58	25.57 Peak
5	295.237	24.75	37.00	-12.25	34.50	13.02	2.74	25.51 Peak
6	348.006	33.68	37.00	-3.32	41.60	14.37	3.06	25.36 Peak
7	402.531	31.53	37.00	-5.47	37.74	15.64	3.36	25.21 Peak
8	541.140	32.67	37.00	-4.33	34.07	18.49	4.78	24.68 Peak

9 RADIATED EMISSION TEST DATA (PAGE 2)



HomeTek Technology Inc.

No 67-9, Shi-Men Rd., Tu-Chen City,  
 Taipei County, Taiwan R.O.C.  
 Tel: 02-22608375  
 Fax: 02-22748013

Data#: 3 File#: 6e016.EMI

Date: 2007-05-16 Time: 17:06:58

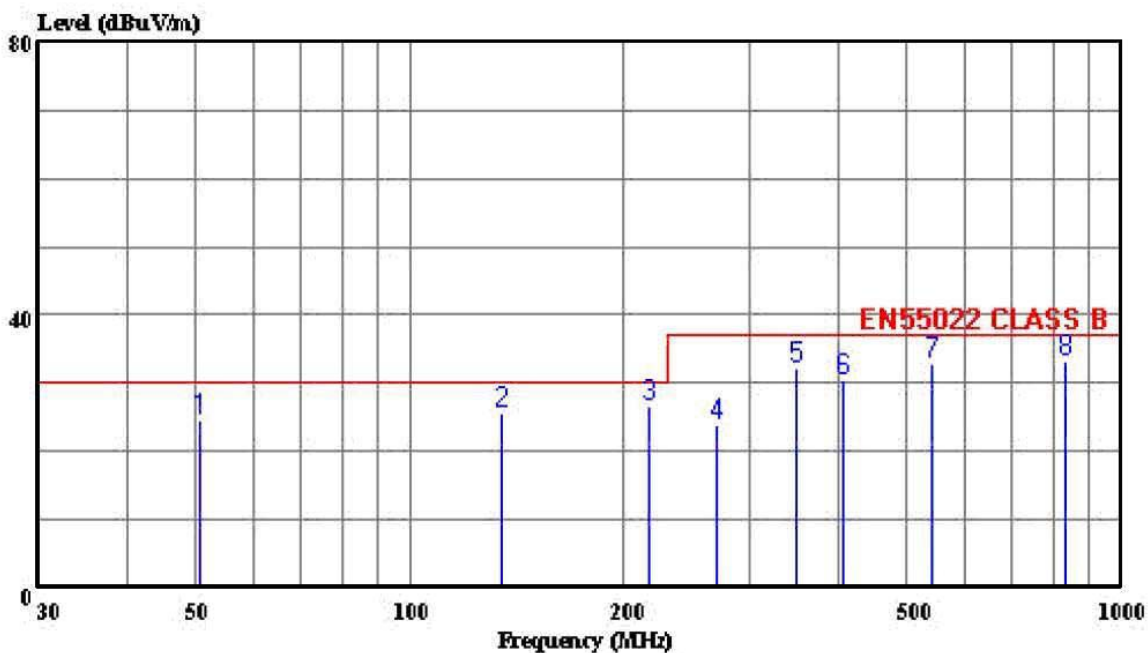

Trace:

Ref Trace:

Condition: EN55022 CLASS B 10m CHASE 2614 060506 VERTICAL  
 eut : 1 input 9 output video & audio CAT5  
 power: 230V/50Hz  
 memo : CE09A

Page: 1

	Limit	Over	ReadAntenna	Cable	Preamp				
Freq	Level	Line	Level	Loss	Factor	Remark			
MHz	dBuV/m	dBuV/m	dB	dB	dB				
1	50.469	24.69	30.00	-5.31	41.37	8.52	0.76	25.97	Peak
2	134.366	25.78	30.00	-4.22	38.42	11.45	1.74	25.83	Peak
3	216.042	26.83	30.00	-3.17	41.17	9.10	2.23	25.68	Peak
4	269.940	24.02	37.00	-12.98	34.37	12.62	2.60	25.56	Peak
5	350.006	32.28	37.00	-4.72	40.10	14.45	3.08	25.36	Peak
6	405.531	30.53	37.00	-6.47	36.62	15.72	3.38	25.19	Peak
7	540.180	32.80	37.00	-4.20	34.30	18.44	4.74	24.68	Peak
8	833.212	33.09	37.00	-3.91	31.50	20.11	5.14	23.66	Peak

## HARMONICS TEST

### 1 TEST INSTRUMENTS & FACILITIES

Instruments/ facilities	Manufacturer	Model # Serial #	Date of Cal.
HARMONICS/ VOLTAGE FLUCTUATIONS TEST	EMC-PARTNER	HAR1000-1P	NOV/2006
CONTROL PC	KB TECH	KB P586/133	N/A

Note : Item 1 were calibrated with two years and verified before testing.

### 2 TEST PROCEDURE

According to EN 61000-3-2 (2000) Class A

### 3 TEST SETUP

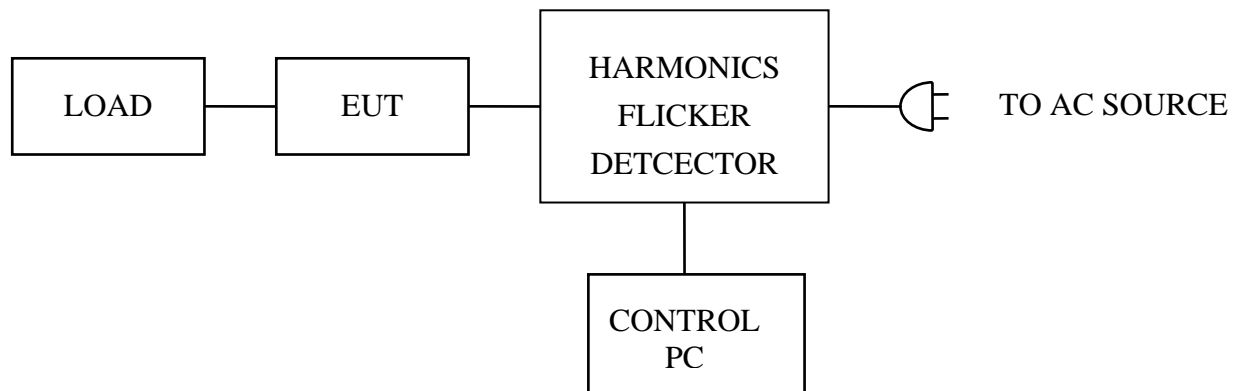

(Details for setup configuration, please refer to appendix A.)

### 4 CONFIGURATION OF THE EUT

Same as “Conducted Power Line test”, section 4

### 5 OPERATION CONDITION OF EUT

Same as “Conducted Power Line test”, section 5

### 6 TEST DATA & LIMIT

6.1 Temperature : 26 °C

6.2 Humidity : 70 % RH

### 7 Photos of test configuration please refer to appendix A.



8 HARMONICS TEST DATA (PAGE 1~2)

EMC PARTNER AG, SWITZERLAND

Date : 2007/5/15 PM 04:24:4 V4.14

Operator : JASON
Unit : 1 input 9 output video & audio CAT5 distribution amplifier
Serialnumber : CE09A
Remarks 6K034

Urms = 229.9V Freq = 50.000 Range: 0.25 A
Irms = 0.075A Ipk = 0.132A cf = 1.759
P = 10.85W S = 17.26VA pf = 0.629
THDi = 42.9 % THDu = 0.10 % Class A

Test - Time : 15min ( 100 %)

Test completed, Result: PASSED

Table with 5 columns: Order, Freq. [Hz], Imax [A], Imax%L [%], Limit [A]. Rows 1-25 showing harmonic test results.



## HomeTek Technology Inc.

26	13000.0000	0.0000	0.0708
27	13500.0003	0.3662	0.0833
28	14000.0000	0.0000	0.0657
29	14500.0003	0.4130	0.0776
30	15000.0000	0.0000	0.0613
31	15500.0002	0.3153	0.0726
32	16000.0000	0.0000	0.0575
33	16500.0002	0.3133	0.0682
34	17000.0000	0.0000	0.0541
35	17500.0002	0.3086	0.0643
36	18000.0000	0.0000	0.0511
37	18500.0002	0.2760	0.0608
38	19000.0000	0.0000	0.0484
39	19500.0002	0.2645	0.0577
40	20000.0000	0.0000	0.0460

Important:

- without "1000-4-7 Ed. 2" ( DFT-window is 16 periods )

## VOLTAGE FLUCTUATIONS TEST

### 1 TEST INSTRUMENTS & FACILITIES

Instruments/ facilities	Manufacturer	Model # Serial #	Date of Cal.
HARMONICS/ VOLTAGE FLUCTUATIONS TEST	EMC-PARTNER	HAR1000-1P	NOV/2006
CONTROL PC	KB TECH	KB P586/133	N/A

Note : Item 1 were calibrated with two years and verified before testing.

### 2 TEST PROCEDURE

According to **EN 61000-3-3 (1995) + A1 (2001)**

### 3 TEST SETUP

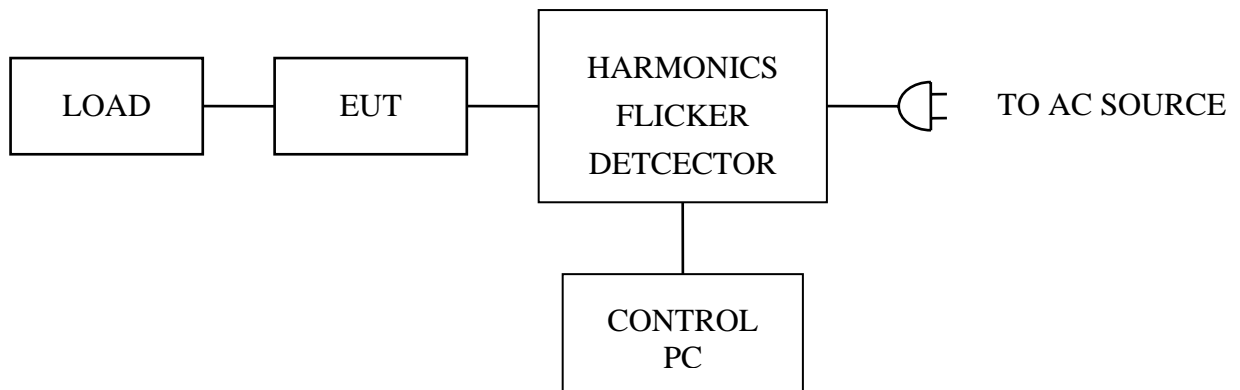

(Details for setup configuration, please refer to appendix A.)

### 4 CONFIGURATION OF THE EUT

Same as “Conducted Power Line test”, section 4

### 5 OPERATION CONDITION OF EUT

Same as “Conducted Power Line test”, section 5

### 6 TEST DATA & LIMIT

6.1 Temperature : 26 °C

6.2 Humidity : 70 % RH

### 7 Photos of test configuration please refer to appendix A.



8 VOLTAGE FLUCTUATIONS TEST DATA (PAGE 1)

EMC PARTNER AG, SWITZERLAND

Date : 2007/5/15 PM 04:43:0 V4.14

Operator : JASON  
 Unit : 1 input 9 output video & audio CAT5 distribution amplifier  
 Serialnumber : CE09A  
 Remarks 6K034

Urms = 229.9V Freq = 49.987 Range: 0.25 A  
 Irms = 0.075A Ipk = 0.131A cf = 1.749  
 P = 10.78W S = 17.20VA pf = 0.627

Test - Time : 1 x 15min = 15min ( 100 %)

LIN (Line Impedance Network) : L: 0.24ohm +j0.15ohm N: 0.16ohm +j0.10ohm

Limits :Plt : 0.65Pst : 1.00  
 dmax : 4.00 % dc : 3.30 %  
 dtLim: 3.30 % dt>Lim: 500ms

Test completed, Result: PASSED

Plt = 0.072

	Pst	dmax
		[%]
1	0.072	0.000



#### 4 CONFIGURATION OF THE EUT

Same as “Conducted Power Line test”, section 4

#### 5 EUT OPERATION CONDITION

Same as “Conducted Power Line test”, section 5

#### 6 TEST CONDITION

##### 6.1 Test Level :

(A)  $\pm 2$ ,  $\pm 4$ ,  $\pm 8$ KV for air discharge.

(B)  $\pm 2$ ,  $\pm 4$ KV for contact discharge.

##### 6.2 Number of test : 10 Discharges / Test point / Polarity / Level

Particular requirements : at least 200 discharges, 100 each at negative and positive polarity, at a minimum of four test points.

##### 6.3 Time between test : 1 sec.

##### 6.4 Temperature : 25 °C

##### 6.5 Humidity : 54 % RH.

#### 7 PERFORMANCE CRITERIA

- A. The apparatus shall continue to operate as intended during and after the test. No degradation of performance or loss of function is allowed below a performance level specified by the manufacturer, when the apparatus is used as intended.
- B. The apparatus shall continue to operate as intended after the test. No degradation of performance or loss of function is allowed below a performance level specified by the manufacturer, when the apparatus is used as intended. The performance level may be replaced by a permissible loss of performance. During the test, degradation of performance is however allowed.
- C. Temporary loss of function is allowed, provided the function is self-recoverable or can be restored by the operation of the controls.

## 8 TEST RESULT

Test Point	Air Discharge	Contact Discharge	Performance Criteria	Result
HCP	---	$\pm 2, \pm 4KV$	B	<b>PASSED</b>
VCP	---	$\pm 2, \pm 4KV$	B	<b>PASSED</b>
CASE	$\pm 2, \pm 4, \pm 8KV$	$\pm 2, \pm 4KV$	B	<b>PASSED</b>
I/O PROTS	$\pm 2, \pm 4, \pm 8KV$	$\pm 2, \pm 4KV$	B	<b>PASSED</b>
LED	$\pm 2, \pm 4, \pm 8KV$	$\pm 2, \pm 4KV$	B	<b>PASSED</b>
SCREWS	$\pm 2, \pm 4, \pm 8KV$	$\pm 2, \pm 4KV$	B	<b>PASSED</b>
DC SOCKET	$\pm 2, \pm 4, \pm 8KV$	$\pm 2, \pm 4KV$	B	<b>PASSED</b>

- ※ The screen was flash and snowflakes in the picture during the test,  
After the test, EUT resume automatically.

## 9 Photos of test configuration please refer to appendix A.

## RADIO FREQUENCY ELECTROMAGNETIC FIELD IMMUNITY TEST (RS)

### 1 TEST INSTRUMENTS & FACILITIES

Item	Instruments Facilities	Manufacturer	Model # Serial #	Data Of Cal.
1	SIGNAL GENERATOR	ROHDE & SCHWARZ	SMY02 845181/025	MAR/2007
2	AMPLIFIER	AMPLIFIER RESEARCH	100W1000M1A	N/A
3	FIELD SENSOR	AMPLIFIER RESEARCH	FP2000	AUG/2006
4	FIELD MONITOR	AMPLIFIER RESEARCH	FM2000	AUG/2006
5	RF VOLTMETER	BOONTON	9200C 361701AA	MAR/2007
6	RF PROBE	BOONTON	952001B 37082	MAR/2007
7	DIRECTION COUPLER	AMPLIFIER RESEARCH	DC6180 20521	N/A
8	ANTENNA	EMCO	3142B S/N: 1789	N/A
9	CONTROL PC	KB TECH	KB P586/133	--

Note : Items 3 ~ 4 were calibrated with two years and verified before testing.

### 2 TEST PROCEDURE

According to **IEC 61000-4-3 (2002)**

According to **EN 55024 (1998) + A1 (2001) + A2 (2003)**

### 3 TEST SETUP

#### FERRITE TILE

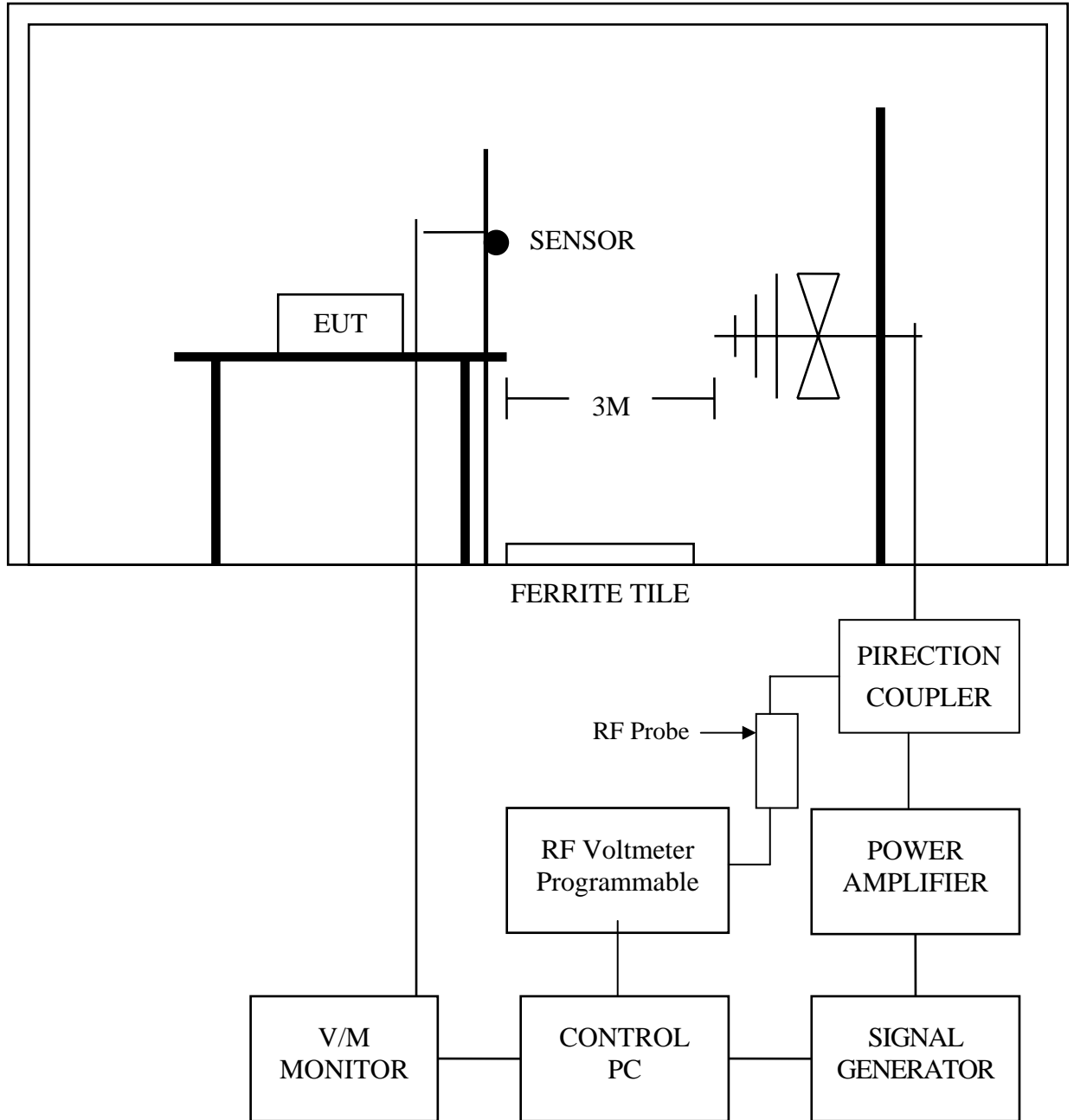

#### 3.1 Chamber Size :

12M x 5M x 5M

(Details for setup configuration, please refer to appendix A.)

#### 4 CONFIGURATION OF THE EUT

Same as “Conducted Power Line test”, section 4

#### 5 OPERATION CONDITION OF EUT

Same as “Conducted Power Line test”, section 5

#### 6 TEST CONDITION

6.1 Frequency Range : 80 MHz ~ 1000 MHz

(Frequency Range : 1.4 GHz ~ 2.0 GHz is not applicable for EN55024:1998+A1:2001+A2:2003)

6.2 Filed Strength : 3 V / M (1KHz 80% Modulation)

6.3 Frequency Step : 1 %, 3 sec. / each step size

6.4 Antenna Polarity : HORIZONTAL & VERTICAL

6.5 The four sides of EUT are tested  
(FRONT, REAR, RIGHT, LEFT)

6.6 Temperature : 26 °C

6.7 Humidity : 70 % RH

#### 7 PERFORMANCE CRITERIA

- A. The apparatus shall continue to operate as intended during and after the test. No degradation of performance or loss of function is allowed below a performance level specified by the manufacturer, when the apparatus is used as intended.
- B. The apparatus shall continue to operate as intended after the test. No degradation of performance or loss of function is allowed below a performance level specified by the manufacturer, when the apparatus is used as intended. The performance level may be replaced by a permissible loss of performance. During the test, degradation of performance is however allowed.
- C. Temporary loss of function is allowed, provided the function is self-recoverable or can be restored by the operation of the controls.

## 8 TEST RESULT

ANT SIDE	HORIZONTAL	VERTICAL	RESULT
FRONT	A	A	PASSED
REAR	A	A	PASSED
RIGHT	A	A	PASSED
LEFT	A	A	PASSED

## 9 Photos of test configuration please refer to appendix A.

## ELECTRICAL FAST TRANSIENT/BURST IMMUNITY TEST (EFT)

### 1 TEST INSTRUMENTS & FACILITIES

Instruments/ Facilities	Manufacturer	Model # Serial #	Data Of Cal.
BURST-TESTER	HAEFELY	PEFT/JUNIOR	FEB/2007
CONTROL PC	KB TECH	KB P586/133	--

### 2 TEST PROCEDURE

According to **IEC 61000-4-4 (2004)**

According to **EN 55024 (1998) + A1 (2001) + A2 (2003)**

### 3 TEST SETUP

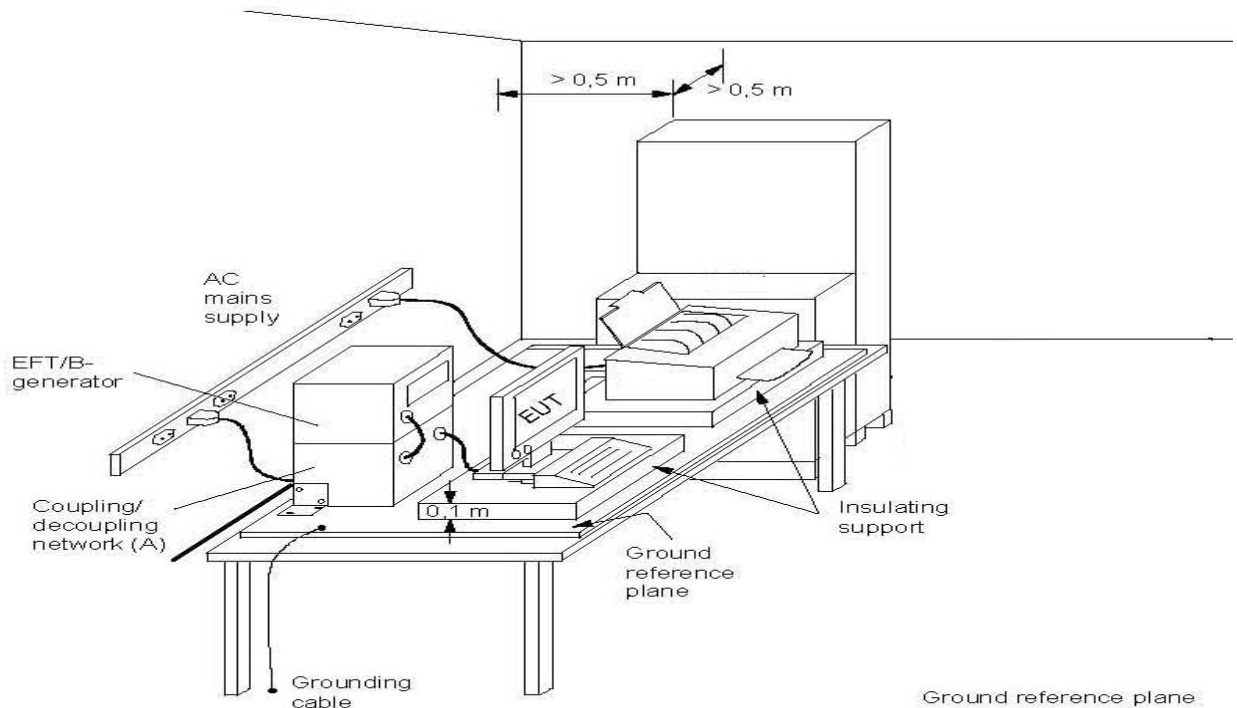

(Details for setup configuration, please refer to appendix A.)

Note: length between clamp and the EUT to be tested (should be  $0.5\text{ m} \pm 0.05\text{ m}$ )

(A) location for supply line coupling

(B) location for signal line coupling

#### 4 CONFIGURATION OF THE EUT

Same as “Conducted Power Line test”, section 4

#### 5 OPERATION CONDITION OF EUT

Same as “Conducted Power Line test”, section 5

#### 6 TEST CONDITION

6.1 Pulse Rise time & Duration : 5 nS / 50 nS

6.2 Pulse Repetition : 5 kHz

6.3 Polarity : POSITIVE / NEGATIVE

6.4 Test Voltage :  $\pm 0.5\text{KV}$ ,  $\pm 1\text{KV}$

6.5 Coupling of power line :

L, N, L+N

6.6 Test Voltage of Signal Control Line :  $\pm 0.25\text{KV}$ ,  $\pm 0.5\text{KV}$

6.7 Temperature : 26 °C

6.8 Humidity : 70 % RH

#### 7 PERFORMANCE CRITERIA

- A. The apparatus shall continue to operate as intended during and after the test. No degradation of performance or loss of function is allowed below a performance level specified by the manufacturer, when the apparatus is used as intended.
- B. The apparatus shall continue to operate as intended after the test. No degradation of performance or loss of function is allowed below a performance level specified by the manufacturer, when the apparatus is used as intended. The performance level may be replaced by a permissible loss of performance. During the test, degradation of performance is however allowed.
- C. Temporary loss of function is allowed, provided the function is self-recoverable or can be restored by the operation of the controls.

8 TEST RESULT

TEST VOLTAGE	L	N	L+N
±0.5KV	B	B	B
±1KV	B	B	B

✘ The screen was flash and snowflakes in the picture during the test, After the test, EUT resume automatically.

Signal Control Line :

TEST VOLTAGE	PERFORMACE CRITERIA
±0.25KV	A
±0.5KV	A

8.1 Model : CE09A

8.2 Final Result : PASSED

8.3 Remark :

9 **Photos of test configuration please refer to appendix A.**

## SURGE IMMUNITY TEST

### 1 TEST INSTRUMENTS & FACILITIES

Instruments/ Facilities	Manufacturer	Model # Serial #	Data Of Cal.
SURGER-TESTER	HAEFELY	PSURGE 4010 583334-38	FEB/2007
CONTROL PC	KB TECH	KB P586/133	--

### 2 TEST PROCEDURE

According To **IEC 61000-4-5 (2001)**

According To **EN 55024 (1998) + A1 (2001) + A2 (2003)**

### 3 TEST SETUP

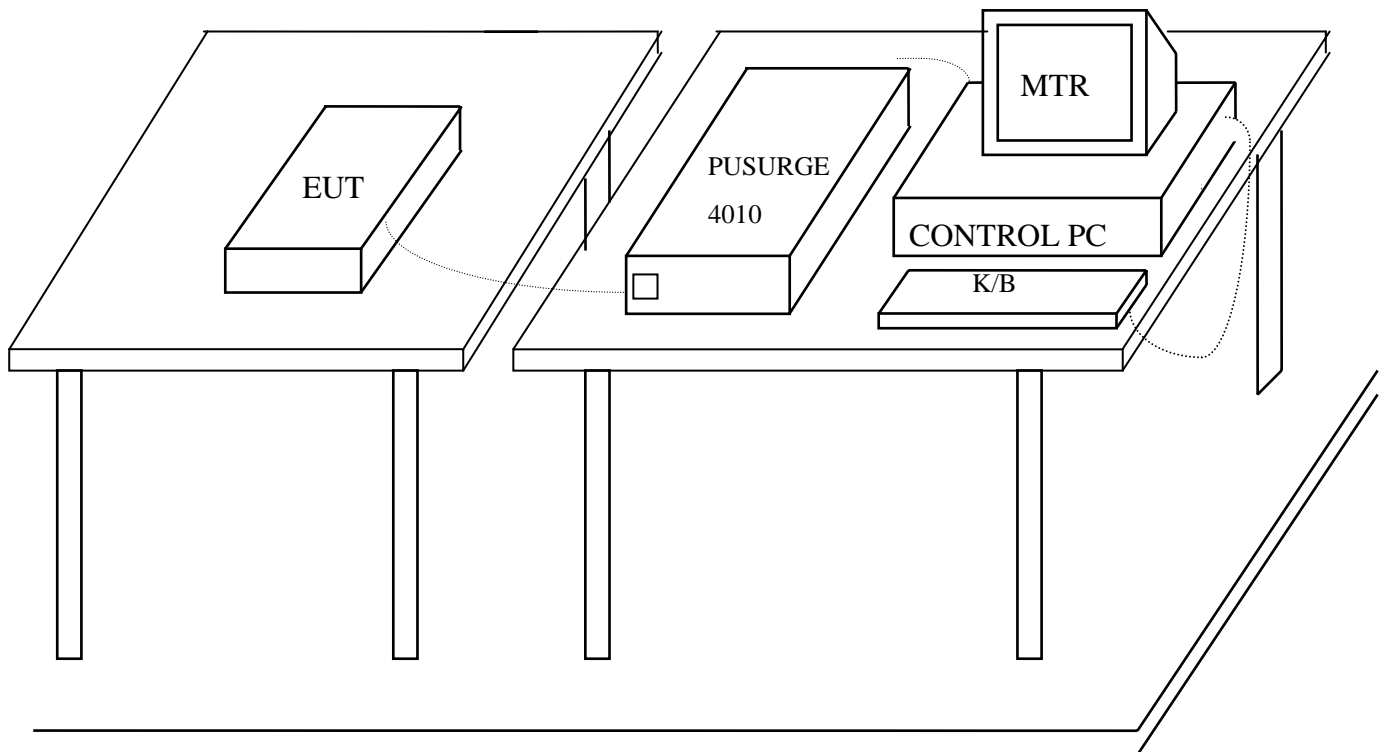

**GROUND PLANE**  
(Details for setup configuration, please refer to appendix A.)

#### 4 TEST LEVELS

- Input and Output AC Power Ports.
- DC Input and DC Output Power Ports.

Environmental Phenomena	Test Specification		Units	Performance Criteria
	AC	DC		
Surges	1.2 / 50 (8/20)		Tr /Th us	
Line to Line	±1	±0.5	KV (Charge Voltage)	B

#### 5 CONFIGURATION OF THE EUT

Same as “Conducted Power Line test”, section 4

#### 6 EUT OPERATION CONDITION

Same as “Conducted Power Line test”, section 5

#### 7 CONDITIONS DURING TESTING

7.1 Coupling of power line :

(A) Line to Line            ±1KV (AC)   or ±0.5KV (DC)

7.2 Polarity : POSITIVE / NEGATIVE

7.3 Phase shifting in a range between 0° to 360°

7.4 Repletion rate at least 1 per min

7.5 Temperature :   26   °C (15°C ~ 35°C)

Humidity :   70   % RH.(10 % ~ 75%)

**8 PERFORMANCE CRITERIA**

- A. The apparatus shall continue to operate as intended during and after the test. No degradation of performance or loss of function is allowed below a performance level specified by the manufacturer, when the apparatus is used as intended.
- B. The apparatus shall continue to operate as intended after the test. No degradation of performance or loss of function is allowed below a performance level specified by the manufacturer, when the apparatus is used as intended. The performance level may be replaced by a permissible loss of performance. During the test, degradation of performance is however allowed.
- C. Temporary loss of function is allowed, provided the function is self-recoverable or can be restored by the operation of the controls.

**9 TEST RESULT**

Environmental Phenomena	Test Specification	Units	Performance
Line to Line	$\pm 1$	KV (Charge Voltage)	A

9.1 Model : CE09A

9.2 Final Result : PASSED

9.3 Remark :

**10 Photos of test configuration please refer to appendix A.**

## IMMUNITY TEST TO CS CONDUCTED DISTURBANCE

### 1 TEST INSTRUMENTS & FACILITIES

Instruments/ Facilities	Manufacturer	Model # Serial #	Date Of Cal.
SIGNAL GENERATOR	ROHDE & SCHWARZ	SMY02 845181/025	MAR/2007
AMPLIFIER	AMPLIFIER RESEARCH	75A250 25680	N/A
RF VOLTMETER	BOONTON	9200C 361701AA	MAR/2007
RF PROBE	BOONTON	952001B 37082	MAR/2007
DIRECTION COUPLER	AMPLIFIER RESEARCH	DC2600 20508	N/A
COUPLING DECOUPLING NETWORK	FCC	FCC-801-M3-25A 9993	FEB/2007
CONTROL PC	KB TECH	KB P586/133	--

### 2 TEST PROCEDURE

According To **IEC 61000-4-6 (2003) + A1 (2004)**

According To **EN 55024 (1998) + A1 (2001) + A2 (2003)**

### 3 TEST SETUP

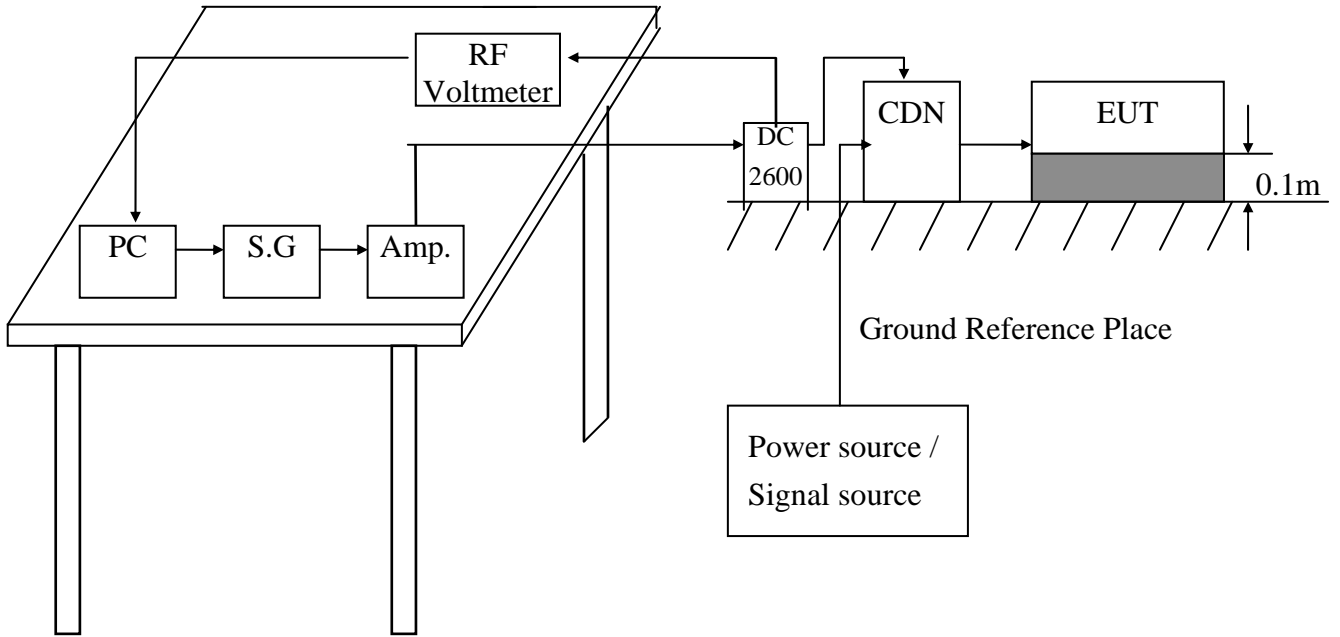

(Details for setup configuration, please refer to appendix A.)

#### 4 TEST LEVELS

- Ports for signal lines and control lines.
- DC input and DC output power ports.
- Input and Output AC Power Ports.
- Functional earth Ports.

Environmental	Test Specification	Units	Performance
Radio-frequency	0.15 - 80	MHz	
Common mode	3	V	A
	80	% AM (1KHz)	

#### 5 CONFIGURATION OF THE EUT

Same as “Conducted Power Line test”, section 4

#### 6 EUT OPERATION CONDITION

Same as “Conducted Power Line test”, section 5

#### 7 CONDITIONS DURING TESTING

7.1 The EUT tested type :

- Single unit
- Multiple unit

7.2 Dwell time : < 1%

7.3 Temperature : 26 °C (15°C ~ 35°C)

Humidity : 70 % RH.(10 % ~ 75%)

**8 PERFORMANCE CRITERIA**

- A. The apparatus shall continue to operate as intended during and after the test. No degradation of performance or loss of function is allowed below a performance level specified by the manufacturer, when the apparatus is used as intended.
- B. The apparatus shall continue to operate as intended after the test. No degradation of performance or loss of function is allowed below a performance level specified by the manufacturer, when the apparatus is used as intended. The performance level may be replaced by a permissible loss of performance. During the test, degradation of performance is however allowed.
- C. Temporary loss of function is allowed, provided the function is self-recoverable or can be restored by the operation of the controls.

**9 TEST RESULT**

TEST Specification	Unit	Performance Criteria
0.15 - 80	MHz	A
3	V	
80	% AM (1KHz)	

9.1 Model : CE09A

9.2 Final Result : PASSED

9.3 Remark :

**10 Photos of test configuration please refer to appendix A.**

## POWER FREQUENCY MAGNETIC FIELD IMMUNITY TEST

### 1 TEST INSTRUMENTS & FACILITIES

Instruments/ Facilities	Manufacturer	Model # Serial #	Data Of Cal.
LINE INTERFERENCE TESTER	HAEFELY	PLINE 1610 080166-10	FEB/2007
MAGNETIC FIELD TESTER	HAEFELY	MAG 100.1 080206-01	N/A
TRIAXIAL ELF MAGNETIC FIELD METER	F.W.BELL	4080 9645	AUG/2006
CONTROL PC	KB TECH	KB P586/133	--

### 2 TEST STANDARD

According To **IEC 61000-4-8 (2001)**

According To **EN 55024 (1998) + A1 (2001) + A2 (2003)**

### 3 TEST SETUP

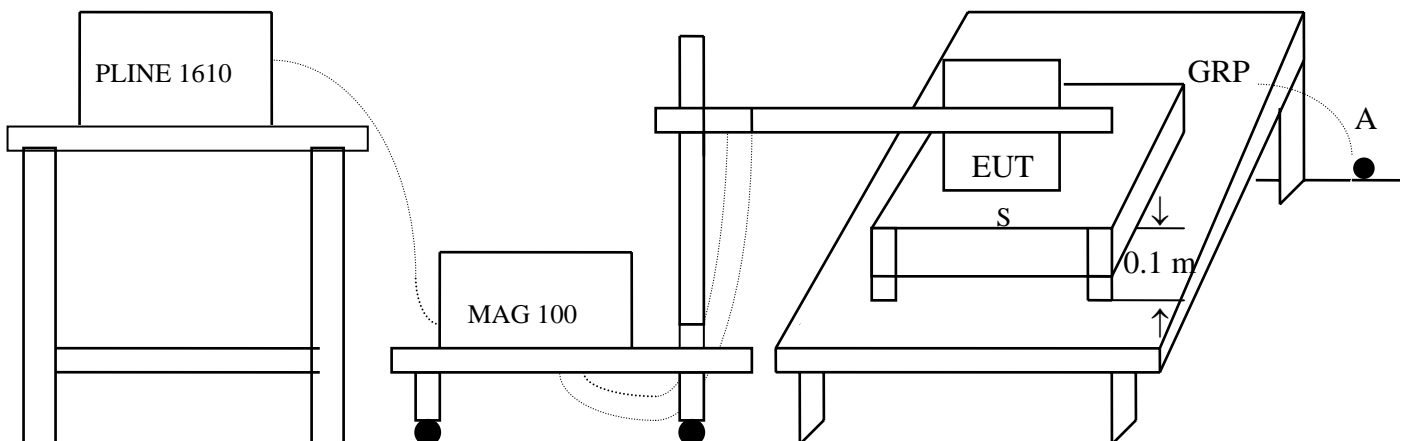

S: Insulating support

A: Safety earth

GRP: Ground plane

(Details for setup configuration, please refer to appendix A.)

#### 4 TEST LEVELS

Environmental Phenomena	Test Specification	Units	Performance Criteria
Power Frequency	50	HZ	
Magnetic Field	1	A/m	B

#### 5 CONFIGURATION OF THE EUT

Same as “Conducted Power Line test”, section 4

#### 6 OPERATION CONDITION OF EUT

Same as “Conducted Power Line test”, section 5

#### 7 CONDITIONS DURING TESTING

7.1 Temperature : 26 °C (15°C ~ 35°C)

Humidity : 70 % RH.(25 % ~ 75%)

7.2 The induction coil shall be rotated by 90°

#### 8 PERFORMANCE CRITERIA

- A. The apparatus shall continue to operate as intended during and after the test. No degradation of performance or loss of function is allowed below a performance level specified by the manufacturer, when the apparatus is used as intended.
- B. The apparatus shall continue to operate as intended after the test. No degradation of performance or loss of function is allowed below a performance level specified by the manufacturer, when the apparatus is used as intended. The performance level may be replaced by a permissible loss of performance. During the test, degradation of performance is however allowed.
- C. Temporary loss of function is allowed, provided the function is self-recoverable or can be restored by the operation of the controls.

## 9 TEST RESULTS

Environmental Phenomena	Test Specification	Units	Performance Criteria
Magnetic Field	1	A/m	A

9.1 Model : CE09A

9.2 Final Results : PASSED

9.3 Remark :

**10 Photos of test configuration please refer to appendix A.**

## VOLTAGE DIPS, SHORT INTERRUPTIONS IMMUNITY TEST

### 1 TEST INSTRUMENTS & FACILITIES

Instruments/ Facilities	Manufacturer	Model # Serial #	Data Of Cal.
LINE INTERFERENCE -TESTER	HAEFELY	PLINE 1610 080166-10	FEB/2007
CONTROL PC	KB TECH	KB P586/133	--

### 2 TEST PROCEDURE

According To **IEC 61000-4-11 (2004)**

According To **EN 55024 (1998) + A1 (2001) + A2 (2003)**

### 3 TEST SETUP

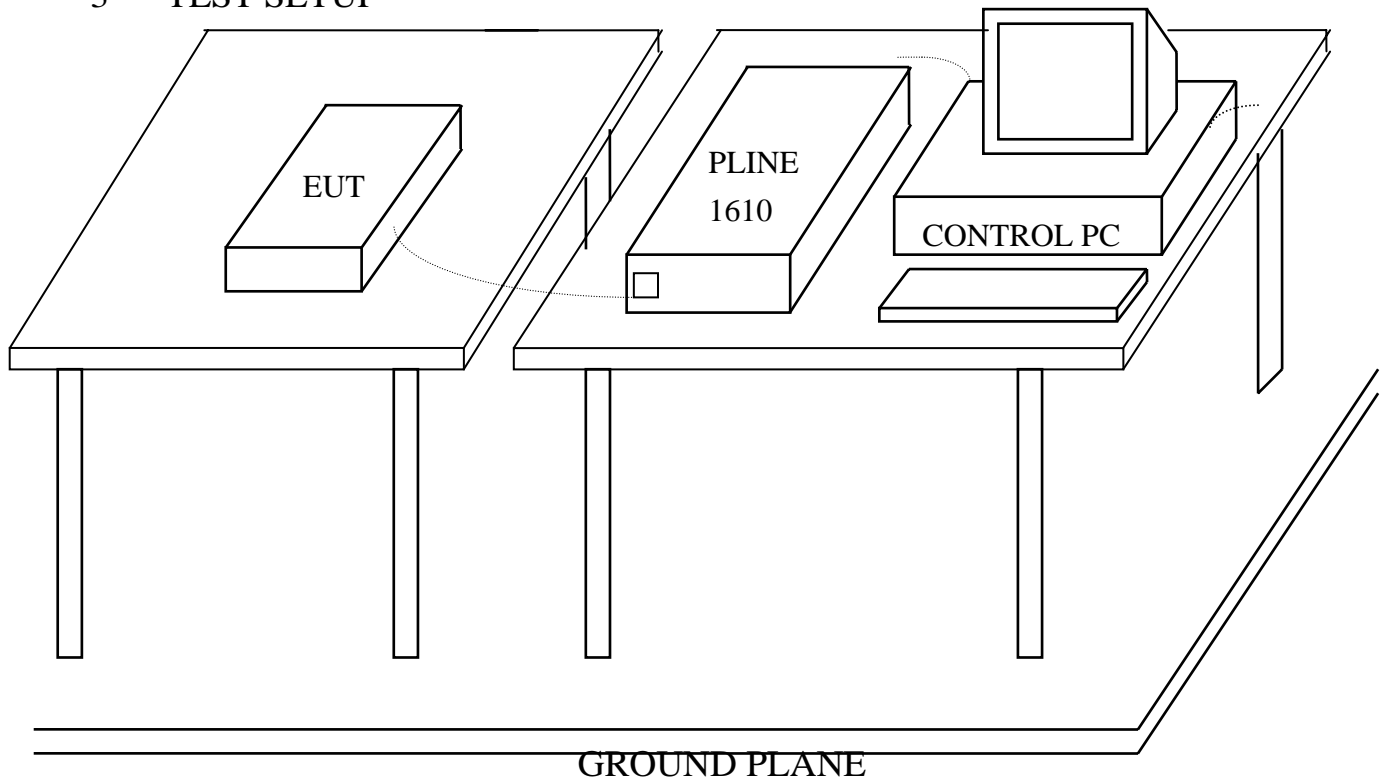

(Details for setup configuration, please refer to appendix A.)

#### 4 TEST LEVELS

Input and Output AC Power Ports.

- Voltage Dips.
- Voltage Interruptions.

Class <sup>a</sup>	Test level and durations for voltage dips				
Class 1	Case-by-case according to the equipment requirements				
Class 2	0 % during 1/2 cycle	0 % during 1 cycle	70 % during 25/30 <sup>c</sup> cycles		
Class 3	0 % during 1/2 cycle	0 % during 1 cycle	40 % during 10/12 <sup>c</sup> cycles	70 % during 25/30 <sup>c</sup> cycles	80 % during 250/300 <sup>c</sup> cycles
a: Classes as per IEC 61000-2-4. b: To be defined by product committee. For equipment connected directly or indirectly to the public network, the levels must not be less severe than Class 2. c: “25/30 cycles” means “25 cycles for 50 Hz test” and “30 cycles for 60 Hz tet”.					

Class <sup>a</sup>	Test level and durations for short interruptions (t <sub>s</sub> ) (50Hz / 60Hz)
Class 1	Case-by-case according to the equipment requirements
Class 2	0 % during 250/300 <sup>c</sup> cycles
Class 3	0 % during 250/300 <sup>c</sup> cycles
Class X <sup>b</sup>	X
a: Classes as per IEC 61000-2-4. b: To be defined by product committee. For equipment connected directly or indirectly to the public network, the levels must not be less severe than Class 2. c: “250/300 cycles” means “250 cycles for 50 Hz test” and “300 cycles for 60 Hz test”.	

✘ **According to the specification of EUT, Class 2 is applied.**

#### 5 CONFIGURATION OF THE EUT

Same as “Conducted Power Line test”, section 4

#### 6 EUT OPERATION CONDITION

Same as “Conducted Power Line test”, section 5

#### 7 CONDITIONS DURING TESTING

7.1 Temperature :   26   °C (15°C ~ 35°C)

Humidity :   70   % RH.(25 % ~ 75%)

## 8 PERFORMANCE CRITERIA

- A. The apparatus shall continue to operate as intended during and after the test. No degradation of performance or loss of function is allowed below a performance level specified by the manufacturer, when the apparatus is used as intended.
- B. The apparatus shall continue to operate as intended after the test. No degradation of performance or loss of function is allowed below a performance level specified by the manufacturer, when the apparatus is used as intended. The performance level may be replaced by a permissible loss of performance. During the test, degradation of performance is however allowed.
- C. Temporary loss of function is allowed, provided the function is self-recoverable or can be restored by the operation of the controls.

## 9 TEST RESULT

Environmental Phenomena	Test Specification	Units	Perform Criteria
Voltage Dips	0 1/2	% during Cycle	A
	0 1	% during Cycle	C
	70 25	% during Cycles	C
Voltage Short Interruptions	0 250	% during Cycles	C

9.1 Model : CE09A

9.2 Final Results : PASSED

9.3 Remark :

## 10 Photos of test configuration please refer to appendix A.



HomeTek Technology Inc.

## **Appendix A**

# **PHOTOS OF TEST CONFIGURATION**

## PHOTO OF CONDUCTED POWER LINE TEST

Model : CE09A



Front View



Rear View

## PHOTO OF RADIATED EMISSION TEST

Model : CE09A



Front View



Rear View

**PHOTO OF HARMONICS & VOLTAGE FLUCTUATIONS TEST  
AND SURGE IMMUNITY TEST AND VOLTAGE DIPS, SHORT  
INTERRUPTIONS IMMUNITY TEST**

Model : CE09A



**PHOTO OF ELECTRICAL FAST TRANSIENT/BURST IMMUNITY  
TEST**



## **PHOTO OF ELECTROSTATIC DISCHARGE IMMUNITY TEST (ESD)**

Model : CE09A



## **PHOTO OF POWER FREQUENCY MAGNETIC FIELD IMMUNITY TEST**



## **PHOTO OF RADIO FREQUENCY ELECTROMAGNETIC FIELD IMMUNITY TEST (RS)**

Model : CE09A



## **PHOTO OF CS CONDUCTED DISTURBANCE IMMUNITY TEST**





HomeTek Technology Inc.

## **Appendix B**

### **PHOTOS OF EUT**

## PHOTO OF EUT

Model :HE09XXX , CE09XXX , YE09XXX



Full View of EUT

## PHOTO OF EUT

Model :HE09XXX , CE09XXX , YE09XXX



Component Side of Main Board 1

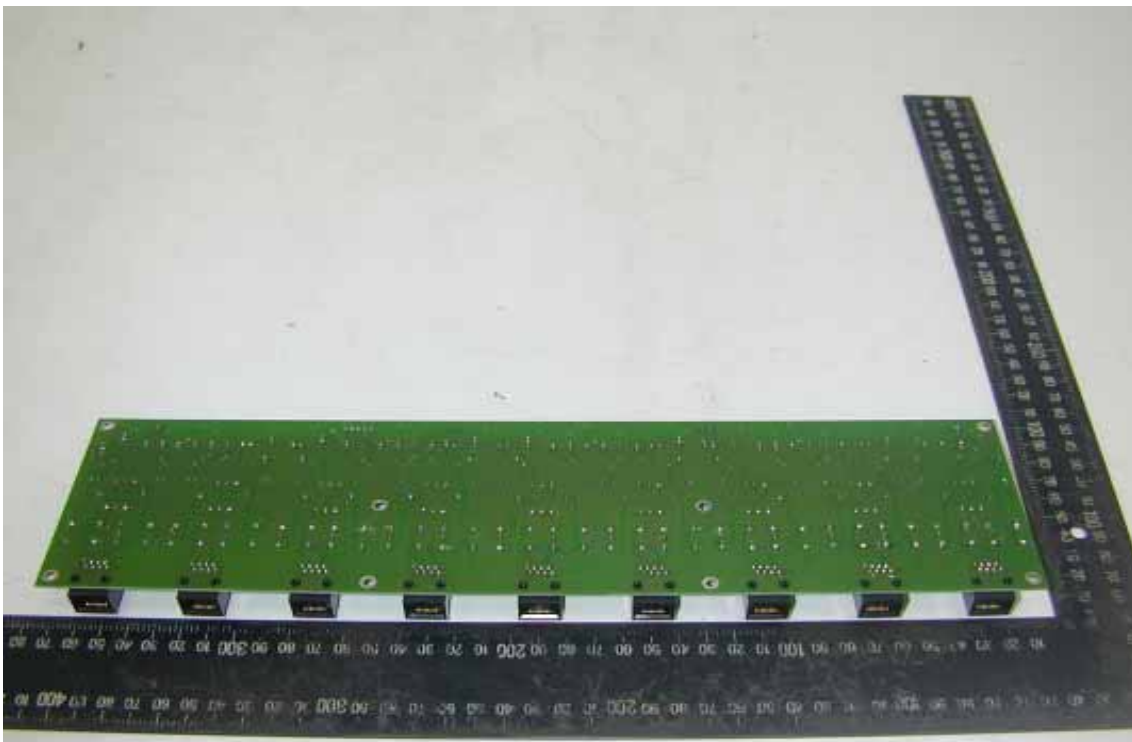

Solder Side of Main Board 1

## PHOTO OF EUT

Model :HE09XXX , CE09XXX , YE09XXX



Component Side of Main Board 2

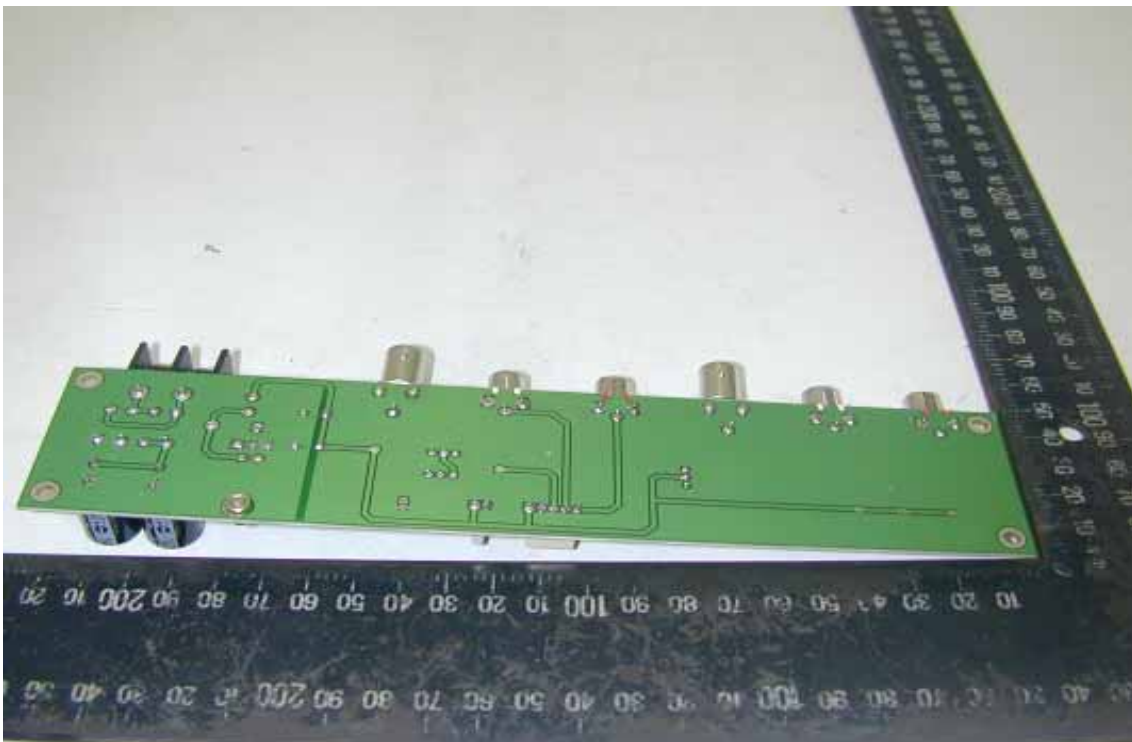

Solder Side of Main Board 2

### PHOTO OF EUT



Front View of Adapter (Model: ADP2411-2)



Rear View of Adapter (Model: ADP2411-2)

# Declaration of Conformity

We(Manufacturer/Importer)

---

(company name)

---

(address)

declares under our sole responsibility that the product

Product name : 1 input 9 output video & audio CAT5 distribution  
amplifier

Model No. : HE09XXX, CE09XXX, YE09XXX

to which this declaration relates is in conformity with the following  
standard(s) or other normative document(s)

- |   |   |
|---|---|
| <input checked="" type="checkbox"/> EN 55022 Class B (1998) | <input checked="" type="checkbox"/> EN 55024 (1998)       |
| + A1 (2000)   | + A1 (2001)   |
| + A2 (2003)   | + A2 (2003)   |
| <input checked="" type="checkbox"/> EN 61000-3-2 (2000)     | <input checked="" type="checkbox"/> IEC 61000-4-2 (2001)  |
| <input checked="" type="checkbox"/> EN 61000-3-3 (1995)     | <input checked="" type="checkbox"/> IEC 61000-4-3 (2002)  |
| + A1 (2001)   | <input checked="" type="checkbox"/> IEC 61000-4-4 (2004)  |
|   | <input checked="" type="checkbox"/> IEC 61000-4-5 (2001)  |
|   | <input checked="" type="checkbox"/> IEC 61000-4-6 (2003)  |
|   | + A1 (2004)   |
|   | <input checked="" type="checkbox"/> IEC 61000-4-8 (2001)  |
|   | <input checked="" type="checkbox"/> IEC 61000-4-11 (2004) |

following the provisions of 2004/108/EC Directive

Place: \_\_\_\_\_ Signature: \_\_\_\_\_

Date : \_\_\_\_\_ Full name: \_\_\_\_\_



Title: \_\_\_\_\_



TÜV Rheinland Taiwan Ltd.

# Certificate

of

# Appointment

for the applicant:

**Hometek Technology Inc.**  
**No. 67-9, Shir Men Rd., Tu-Cheng City,**  
**Taipei Hsien 236, Taiwan, R.O.C.**

has been authorized to carry out EMC tests by order and under supervision of TÜV Rheinland. It has successfully demonstrated capability to conduct measurement and to process test data according to:

**European and International EMC Standards as listed in the  
Scope of Authorization on the attachment to this certificate**

An assessment of the facility was conducted by TÜV Rheinland auditors according to the TÜV Rheinland requirements for "Test Site Approval" with reference to

**ISO 17 025:1999**

**Certificate No. : 10012161-2006**

**Valid until : June 14, 2007**

TÜV Rheinland Taiwan Ltd.  
**Taipei, April 13, 2006**

  
Dipl.-Ing. Andreas Klinker  
Certification Body

  
Dipl.-Ing. Bodo Kretzschmar  
Product Safety and Quality



Attachment to  
**Certificate**  
of Appointment

SCOPE OF AUTHORIZATION

Hometek Technology Inc.  
No. 67-9, Shir Men Rd., Tu-Cheng City,  
Taipei Hsien 236, Taiwan, R.O.C.

**European Standards**

EN 50081-1	EN 61000-3-2	ENV 50140
EN 50081-2	EN 61000-3-3	ENV 50141
EN 50082-1	EN 61000-6-1	ENV 50204
EN 50130-4	EN 61000-6-2	
EN 50091-2	EN 61000-6-3	
EN 55011	EN 61000-6-4	
EN 55013	EN 61000-3-11	
EN 55014-1	EN 61000-4-2	
EN 55014-2	EN 61000-4-3	
EN 55022	EN 61000-4-4	
EN 55024	EN 61000-4-5	
EN 60601-1-2	EN 61000-4-6	
EN 60801	EN 61000-4-8	
EN 60945	EN 61000-4-11	
	EN 61204-3	

**International Standards**

CISPR 11	IEC 61000-4-2	IEC 61000-3-2
CISPR 13	IEC 61000-4-3	IEC 61000-3-3
CISPR 14-1	IEC 61000-4-4	IEC 61000-3-11
CISPR 14-2	IEC 61000-4-5	IEC 61000-6-1
CISPR 22	IEC 61000-4-6	IEC 61000-6-2
CISPR 24	IEC 61000-4-8	IEC 61000-6-3
	IEC 61000-4-11	IEC 61000-6-4
IEC 801.2	IEC 61000-4-12	IEC 60945
IEC 801.3		
IEC 801.4		

Certificate No. : 10012161-2006

Taipei, April 13, 2006

  
Dipl.-Ing. Bodo Kretzschmar  
Product Safety and Quality



TÜV Rheinland Taiwan Ltd.

# Certificate of Appointment

for the applicant:

**Hometek Technology Inc.  
No. 67-9, Shir Men Rd., Tu-Cheng City,  
Taipei Hsien 236, Taiwan, R.O.C.**

has been authorized to carry out EMC tests by order and under supervision of TÜV Rheinland. It has successfully demonstrated capability to conduct measurement and to process test data according to:

**European and International EMC Standards as listed in the  
Scope of Authorization on the attachment to this certificate**

An assessment of the facility was conducted by TÜV Rheinland auditors according to the TÜV Rheinland requirements for "Test Site Approval" with reference to

**ISO 17025: 2005**

Certificate No. : 10012161-2007

Valid until : Sept. 7, 2008

TÜV Rheinland Taiwan Ltd.  
Taipei, June 20, 2007

  
Dipl.-Ing. Andreas Klinker  
Certification Body

  
Dipl.-Ing. Bodo Kretzschmar  
Product Safety and Quality



Attachment to  
**Certificate**  
of Appointment

SCOPE OF AUTHORIZATION

**Hometek Technology Inc.**  
No. 67-9, Shir Men Rd., Tu-Cheng City,  
Taipei Hsien 236, Taiwan, R.O.C.

**European Standards**

EN 50081-1	EN 61000-3-3	ENV 50140
EN 50081-2	EN 61000-6-1	ENV 50141
EN 50082-1	EN 61000-6-2	ENV 50204
EN 50130-4	EN 61000-6-3	
EN 50091-2	EN 61000-6-4	
EN 55011	EN 61000-3-11	
EN 55013	EN 61000-4-2	
EN 55014-1	EN 61000-4-3	
EN 55014-2	EN 61000-4-4	
EN 55022	EN 61000-4-5	
EN 55024	EN 61000-4-6	
EN 60601-1-2	EN 61000-4-8	
EN 60801	EN 61000-4-11	
EN 60945	EN 61204-3	
EN 61000-3-2	EN 62040-2	

**International Standards**

CISPR 11	IEC 61000-4-2	IEC 61000-3-2
CISPR 13	IEC 61000-4-3	IEC 61000-3-3
CISPR 14-1	IEC 61000-4-4	IEC 61000-3-11
CISPR 14-2	IEC 61000-4-5	IEC 61000-6-1
CISPR 22	IEC 61000-4-6	IEC 61000-6-2
CISPR 24	IEC 61000-4-8	IEC 61000-6-3
IEC 801.2	IEC 61000-4-11	IEC 61000-6-4
IEC 801.3	IEC 61000-4-12	IEC 60945
IEC 801.4		IEC 62040-2

Certificate No. : 10012161-2007

Taipei, June 20, 2007

  
Dipl.-Ing. Bodo Kretzschmar  
Product Safety and Quality