



ADDRESS: No. 67-9, Shir Men Road, Tu Cheng City,  
Taipei Hsien, Taiwan

PHONE : 886-2-22608375 FAX : 886-2-22748013

E - mail : hometek@ms15.hinet.net

## CE TEST REPORT FOR

APPLICANT : Smart Home Engineering Corp.  
ADDRESS : 10F., No. 493, Chung-Cheng Rd.,  
Hsin-Tien City, Taipei 231, Taiwan, R. O. C.  
Receipt Date : 11/08/2007 Final Test Date: 12/12/2007  
EUT : Multimedia AV Switcher  
MODEL NO. : HS0XXX

### MEASUREMENT PROCEDURE USED

EN55022 CLASS B / EN61000-3-2 / EN61000-3-3 / EN55024 GIVEN IN  
EUROPEAN COUNCIL DIRECTIVE 2004/108/EC

This test result of this report applies to above tested sample only.

This test report shall not be reproducing in part without written approval of HomeTek Technology Inc.

PREPARED BY :

HomeTek Technology Inc.

No. 67-9, Shir Men Road, Tu Cheng City,

Taipei Hsien. Taiwan

Report # : EB6K008

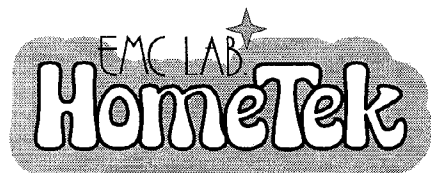

HomeTek Technology Inc.

ADDRESS: No. 67-9, Shir Men Road, Tu Cheng City,  
Taipei Hsien

PHONE : 886-2-22608375 FAX : 886-2-22748013

E - mail : hometek@ms15.hinet.net

## CERTIFICATE OF COMPLIANCE

EUT : Multimedia AV Switcher

MODEL NO. : HS0XXX

Receipt Date : 11/08/2007 Final Test Date: 12/12/2007

REPORT # : EB6K008

APPLICANT : Smart Home Engineering Corp.

ADDRESS : 10F., No. 493, Chung-Cheng Rd.,  
Hsin-Tien City, Taipei 231, Taiwan, R. O. C.

Measurement procedure used:

**EMI: EN 55022 Class B (1998) + A1 (2000) + A2 (2003),**  
**EN 61000-3-2 (2006), EN 61000-3-3 (1995) + A1 (2001) + A2 (2005),**  
**EMS: EN 55024 (1998) + A1 (2001) + A2 (2003):**  
**IEC 61000-4-2 (2001), IEC 61000-4-3 (2002), IEC 61000-4-4 (2004), IEC 61000-4-5 (2001),**  
**IEC 61000-4-6 (2003) + A1 (2004), IEC 61000-4-8 (2001), IEC 61000-4-11 (2004)**

We hereby show that:

The measurements shown in this test report were made in accordance with the procedures given in **EUROPEAN COUNCIL DIRECTIVE 2004/108/EC**, and the energy emitted by the equipment was found to be within the limits applicable. This product, which has been issued the test report listed as above in HomeTek Technology Inc., is based on single evaluation of one sample and confirmed to comply with the requirements of the above-mentioned EMC standard.

APPROVED BY :



GRANT HUANG / Manager

EB6K008

**TEST REPORT CERTIFICATION**

**EMC of electrical appliances**

Report reference No. : EB6K008  
 Date of issue : Dec., 15, 2007  
 Applicant : Smart Home Engineering Corp.  
 Address : 10F., No. 493, Chung-Cheng Rd.,  
 Hsin-Tien City, Taipei 231, Taiwan, R. O. C.  
 Manufacturer : Smart Home Engineering Corp.  
 Type of test object : Multimedia AV Switcher  
 Model/type reference : HS0XXX  
 EUT Voltage : DC5V  
 Test Result : Complied  
 Testing laboratory : HomeTek Technology Inc.  
 Address : No. 67-9, Shir Men Road, Tu Cheng City, Taipei Hsien,  
 Taiwan, R. O. C.  
 TEL / FAX : +886-2-22608375 / +886-2-22748013  
 E-MAIL : hometek@ms15.hinet.net  
 Standard : EN 55022 Class B (1998) + A1 (2000) + A2 (2003),  
 EN 61000-3-2 (2006),  
 EN 61000-3-3 (1995) + A1 (2001) + A2 (2005),  
 EN 55024 (1998) + A1 (2001) + A2 (2003):  
 IEC 61000-4-2 (2001), IEC 61000-4-3 (2002),  
 IEC 61000-4-4 (2004), IEC 61000-4-5 (2001),  
 IEC 61000-4-6 (2003) + A1 (2004), IEC 61000-4-8 (2001),  
 IEC 61000-4-11 (2004)

Tested by (+ signature) : *Jason Lin / Engineer* 

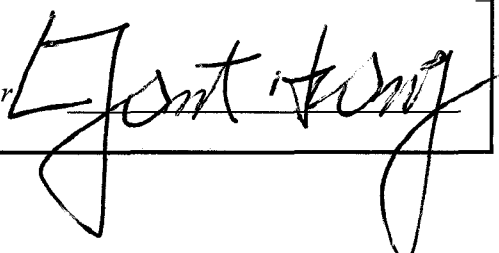
Approved by (+ signature) : *GRANT HUANG / Manager* 



**TEST REPORT CERTIFICATION..... 1**

**TABLE OF CONTENTS..... 2**

**TEST REPORT CERTIFICATION..... 1**

**GENERAL INFORMATION..... 5**

**MODIFICATION LIST..... 7**

**CONDUCTED POWER LINE TEST ..... 8**

1 TEST INSTRUMENTS & FACILITIES..... 8

2 TEST PROCEDURE..... 8

3 TEST SETUP ..... 9

4 CONFIGURATION OF THE EUT ..... 11

5 EUT OPERATING CONDITION..... 13

6 LIMIT OF CONDUCTED POWER LINE EMISSION CLASS B..... 13

7 RESULT OF CONDUCTED POWER LINE TEST..... 13

8 CONDUCTED POWER LINE TEST DATA (PAGE 1)..... 14

9 CONDUCTED POWER LINE TEST DATA (PAGE 2)..... 15

10 CONDUCTED POWER LINE TEST DATA (PAGE 3)..... 16

11 CONDUCTED POWER LINE TEST DATA (PAGE 4)..... 17

**RADIATED EMISSION TEST..... 18**

1 TEST INSTRUMENTS & FACILITIES..... 18

2 TEST PROCEDURE..... 19

3 TEST SETUP ..... 19

4 CONFIGURATION OF THE EUT ..... 21

5 EUT OPERATING CONDITION..... 21

6 LIMIT OF RADIATED EMISSION CLASS B ..... 21

7 RESULT OF RADIATED EMISSION TEST..... 21

8 RADIATED EMISSION TEST DATA (PAGE 1)..... 22

9 RADIATED EMISSION TEST DATA (PAGE 2)..... 23

**HARMONICS TEST..... 24**

1 TEST INSTRUMENTS & FACILITIES..... 24

2 TEST PROCEDURE..... 24

3 TEST SETUP ..... 24

4 CONFIGURATION OF THE EUT ..... 24

5 OPERATION CONDITION OF EUT ..... 24

6 TEST DATA & LIMIT..... 24

7 HARMONICS TEST DATA (PAGE 1~2)..... 25

**VOLTAGE FLUCTUATIONS TEST ..... 27**

1 TEST INSTRUMENTS & FACILITIES..... 27

2 TEST PROCEDURE..... 27

3 TEST SETUP ..... 27



4 CONFIGURATION OF THE EUT ..... 27

5 OPERATION CONDITION OF EUT ..... 27

6 TEST DATA & LIMIT ..... 27

7 VOLTAGE FLUCTUATIONS TEST DATA (PAGE 1) ..... 28

**ELECTROSTATIC DISCHARGE IMMUNITY TEST (ESD) ..... 29**

1 TEST INSTRUMENTS & FACILITIES ..... 29

2 TEST PROCEDURE ..... 29

3 TEST SETUP ..... 29

4 CONFIGURATION OF THE EUT ..... 30

5 EUT OPERATION CONDITION ..... 30

6 TEST CONDITION ..... 30

7 PERFORMANCE CRITERIA ..... 30

8 TEST RESULT ..... 31

**RADIO FREQUENCY ELECTROMAGNETIC FIELD IMMUNITY TEST (RF) ..... 32**

1 TEST INSTRUMENTS & FACILITIES ..... 32

2 TEST PROCEDURE ..... 32

3 TEST SETUP ..... 33

4 CONFIGURATION OF THE EUT ..... 34

5 OPERATION CONDITION OF EUT ..... 34

6 TEST CONDITION ..... 34

7 PERFORMANCE CRITERIA ..... 34

8 TEST RESULT ..... 35

**ELECTRICAL FAST TRANSIENT/BURST IMMUNITY TEST (EFT) ..... 36**

1 TEST INSTRUMENTS & FACILITIES ..... 36

2 TEST PROCEDURE ..... 36

3 TEST SETUP ..... 36

4 CONFIGURATION OF THE EUT ..... 37

5 OPERATION CONDITION OF EUT ..... 37

6 TEST CONDITION ..... 37

7 PERFORMANCE CRITERIA ..... 37

8 TEST RESULT ..... 38

**SURGE IMMUNITY TEST ..... 39**

1 TEST INSTRUMENTS & FACILITIES ..... 39

2 TEST PROCEDURE ..... 39

3 TEST SETUP ..... 39

4 TEST LEVELS ..... 40

5 CONFIGURATION OF THE EUT ..... 40

6 EUT OPERATION CONDITION ..... 40

7 CONDITIONS DURING TESTING ..... 40

8 PERFORMANCE CRITERIA ..... 41



9 TEST RESULT ..... 41

**IMMUNITY TEST TO CS CONDUCTED DISTURBANCE ..... 42**

1 TEST INSTRUMENTS & FACILITIES..... 42

2 TEST PROCEDURE..... 42

3 TEST SETUP ..... 43

4 TEST LEVELS..... 44

5 CONFIGURATION OF THE EUT ..... 44

6 EUT OPERATION CONDITION..... 44

7 CONDITIONS DURING TESTING..... 44

8 PERFORMANCE CRITERIA ..... 45

9 TEST RESULT ..... 45

**POWER FREQUENCY MAGNETIC FIELD IMMUNITY TEST ..... 46**

1 TEST INSTRUMENTS & FACILITIES..... 46

2 TEST STANDARD..... 46

3 TEST SETUP ..... 46

4 TEST LEVELS..... 47

5 CONFIGURATION OF THE EUT ..... 47

6 OPERATION CONDITION OF EUT..... 47

7 CONDITIONS DURING TESTING..... 47

8 PERFORMANCE CRITERIA ..... 47

9 TEST RESULTS ..... 48

**VOLTAGE DIPS, SHORT INTERRUPTIONS IMMUNITY TEST ..... 49**

1 TEST INSTRUMENTS & FACILITIES..... 49

2 TEST PROCEDURE..... 49

3 TEST SETUP ..... 49

4 TEST LEVELS..... 50

5 CONFIGURATION OF THE EUT ..... 50

6 EUT OPERATION CONDITION..... 50

7 CONDITIONS DURING TESTING..... 50

8 PERFORMANCE CRITERIA ..... 51

9 TEST RESULT ..... 51

**APPENDIX A**

PHOTOS OF TEST CONFIGURATION

**APPENDIX B**

PHOTOS OF EUT

**GENERAL INFORMATION**

- 1 APPLICANT : Smart Home Engineering Corp.
- 2 ADDRESS : 10F., No. 493, Chung-Cheng Rd.,  
Hsin-Tien City, Taipei 231, Taiwan, R. O. C.
- 3 MANUFACTURER : Smart Home Engineering Corp.
- 4 ADDRESS : 10F., No. 493, Chung-Cheng Rd.,  
Hsin-Tien City, Taipei 231, Taiwan, R. O. C.
- 5 DESCRIPTION OF EUT :
- EUT : Multimedia AV Switcher
- Model : HS0XXX
- Serial # : N/A

5.1 The difference between series of models HS0XXX are as shown below:

- (1) The first “X” represents different system input.
- (2) The second “X” represent different accessory.
- (3) The third “X” represent different color.

The PCB layout is similar. The worst case of EMC test data were shown in this test report.

## 6 FEATURES OF EUT :

HDMI Input	4 pot (HDMI Type A)
HDMI Output	1 pot (HDMI Type A)
Frequency Bandwidth	1.65Ghz
Supports Resolution	480i, 576i, 480p, 720p, 1080i, 1080p
Operation Temperature	-10°C ~45°C
Storage Temperature	-30°C ~70°C
Power Supply	DC5V 1AMP included
Dimensions W x H x D mm	225 x 160 x 40

## 7 TEST MODE :

The EUT were investigated with four modes shown as below :

- (1) HDMI in 1 and HDMI out Mode;
- (2) HDMI in 2 and HDMI out Mode;
- (3) HDMI in 3 and HDMI out Mode;
- (4) HDMI in 4 and HDMI out Mode;

The test mode of (4) HDMI in 4 and HDMI out Mode is worst case, and the final test data were shown in this test report.



HomeTek Technology Inc.

## **MODIFICATION LIST**

**THE FOLLOWING ACCESSORIES WERE ADDED TO THE EUT DURING TESTING :**

**NO MODIFICATION BY HOMETEK TECHNOLOGY INC.**

## CONDUCTED POWER LINE TEST

### 1 TEST INSTRUMENTS & FACILITIES

The following test Instruments was used during the conducted test :

Item	Instruments/ Facilities	Specification	Manufacturer	Model #	Date Of Cal.
1	EMI Receiver	9KHz ~ 30MHz	ROHDE & SCHWARZ	ESHS10 840449/001	DEC/2006
2	LISN (for EUT)	50Ω/50uH/16A 9KHz ~ 30MHz	AFJ	LT32 32039930056	DEC/2006
3	LISN (for Support Unit)	50Ω/50uH/15A 150KHz ~ 30MHz	SANKI	LISN1-15V 080404E	DEC/2006
4	Terminator	50Ω	N/A	N/A	DEC/2006
5	Attenuation	50Ω/10dB	Mini-Circuit	NAT-10 AT-002	DEC/2006
6	Cable	5.4m	SUHNER	RG-223 CON2-001	DEC/2006
7	ESXS-K1 (software)	Version 2.03b 9KHz ~ 30MHz	ROHDE & SCHWARZ	1082.9678.02 840.913/246	N/A

Note : Items 1 ~ 6 were calibrated within period of 1 year.

### 2 TEST PROCEDURE

- 2.1 The EUT was tested according to **EN55022 Class B**.
- 2.2 The EUT was placed 0.4 meter from the conducting wall of shielding room and kept at least 0.8 meter from any other grounded conducting surface.
- 2.3 The frequency range form 0.15 MHz to 30 MHz was investigated.
- 2.4 The LISN used was 50 Ohm / 50 uHenry as specified by **EN55022**.
- 2.5 All the support peripherals are connect to the other LISN.
- 2.6 Cables and peripherals were moved to find the maximum emission levels for each frequency.

### 3 TEST SETUP

#### 3.1 Typical : Setup Of Conducted Test

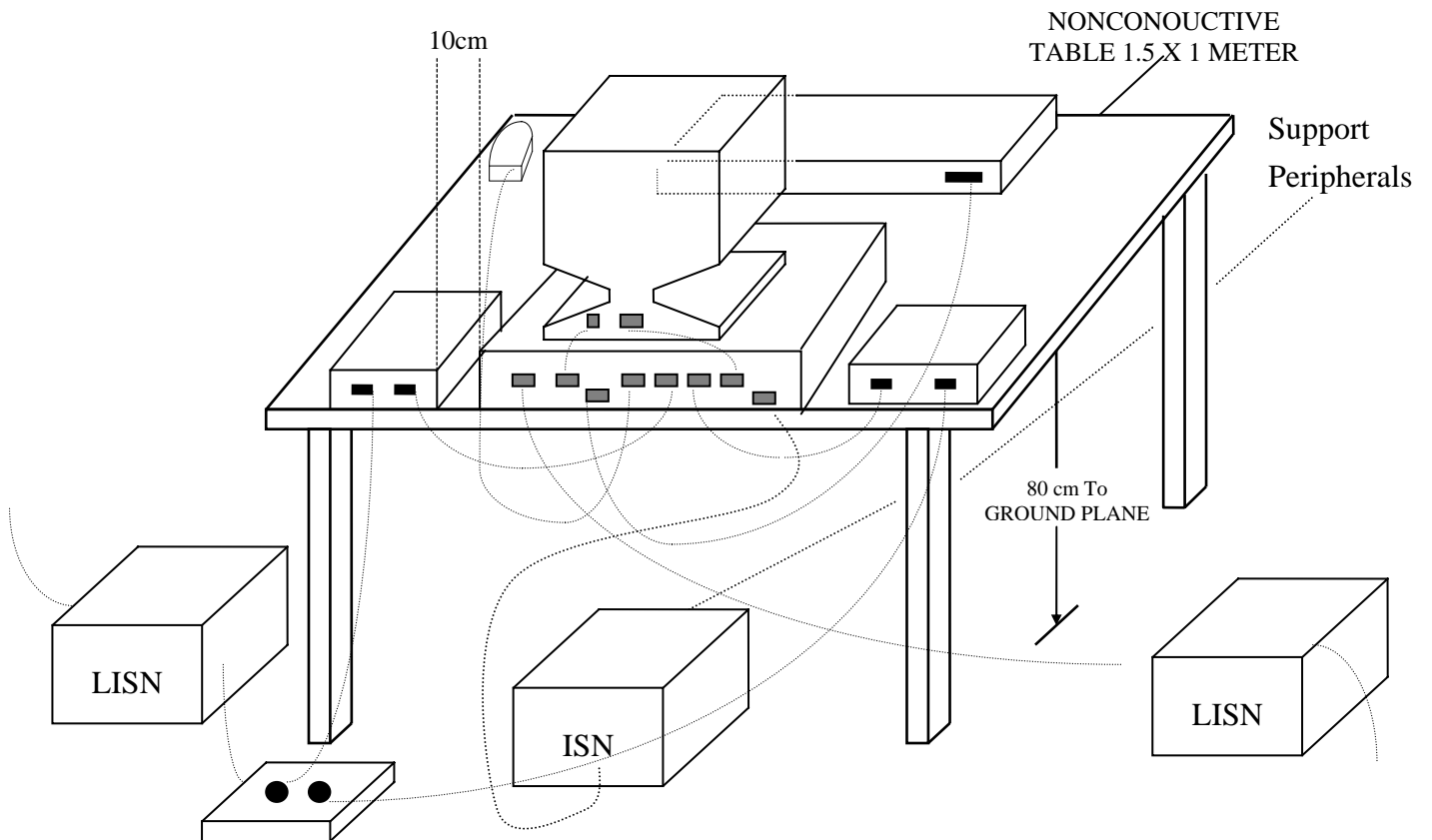

(Details for setup configuration, please refer to appendix A.)

## 3.2 Block Diagram Of Conducted Test

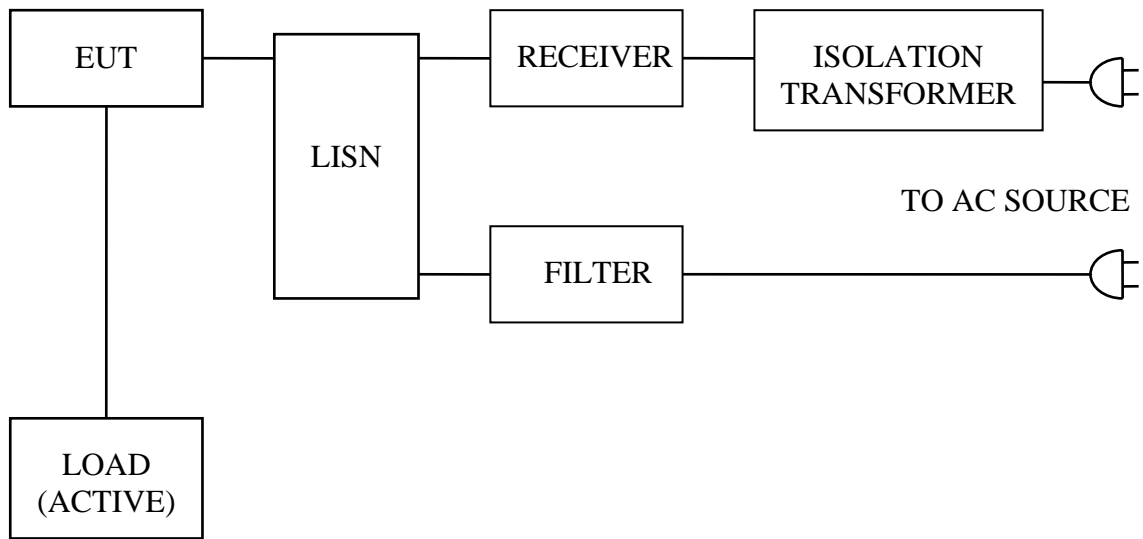

- DVD Player
- TV
- Power Adapter



## 4 CONFIGURATION OF THE EUT

The EUT was configured according to **EN55022**. All I/O ports were connected to the appropriate peripherals. All peripherals and cables are listed below (including internal device) :

### 4.1 EUT

EUT Type	: <input type="checkbox"/> Proto Type <input checked="" type="checkbox"/> Engineer Type <input type="checkbox"/> Mass Production
Condition when received	: <input checked="" type="checkbox"/> Good <input type="checkbox"/> Damage : _____
Device	: Multimedia AV Switcher
Applicant	: Smart Home Engineering Corp.
Manufacturer	: Smart Home Engineering Corp.
Model Number	: HS0XXX
Serial Number	: N/A
FCC ID	: N/A
HDMI In Cable x1	: Shielded, 1 m, Metal Type Connector
HDMI Out Cable x4	: Shielded, 1 m, Metal Type Connector
Power Cord (AC)	: Direct-plug in, 2 pin
Power Cord (DC)	: Un-Shielded, 1.75 m
Power Supply Type	: Switching Power Adapter

#### 4.2 PERIPHERALS

DVD Player

Manufacturer : Philips  
Model Number : DVP5960193  
Serial Number : N/A  
FCC ID : FCC DoC  
Power Cord : Un-Shielded, 1.5 m

TV

Manufacturer : SAMSUNG  
Model Number : LA26R51B  
Serial Number : N/A  
FCC ID : FCC DoC  
Power Cord : Un-Shielded, 1.5 m

Power Adapter

Manufacturer : ELEC  
Model Number : ADP051200R-2  
Serial Number : N/A  
FCC ID : N/A  
Data Cable : N/A  
Power Cord (DC) : Un-Shielded, 1.75 m

#### 4.3 REMARK : N/A

## 5 EUT OPERATING CONDITION

- 5.1 The frequency of the EUT is none.
- 5.2 Configure the EUT according to the **ANSI C63.4 - 2003 & CISPR 22 - 1997**.
- 5.3 The test configuration included DVD Player, TV and Power Adapter.
- 5.4 Turn on all the power of EUT and peripheral.
- 5.5 Playing the DVD.
- 5.6 Adjust the location of EUT and peripheral to gain the maximum EMI noise.
- 5.7 The photos of conducted test configuration, please refer to appendix A.**

## 6 LIMIT OF CONDUCTED POWER LINE EMISSION CLASS B

Frequency Range	Quasi Peak	Average
0.15 ~ 0.5 MHz	66 - 56 dBuV	56 - 46 dBuV
0.5 ~ 5 MHz	56 dBuV	46 dBuV
5 ~ 30 MHz	60 dBuV	50 dBuV

## 7 RESULT OF CONDUCTED POWER LINE TEST

- 7.1 The frequency range from 0.15 MHz to 30 MHz was investigated. All readings are quasi-peak values and average.
- 7.2 IF bandwidth : 9 kHz, Meas Time : 1 sec.
- 7.3 Temperature : 24.3 °C, Humidity : 50 % RH.
- 7.4 Deviations from the test standards and rules : None.
- 7.5 The conducted test result were gained by following procedures :  
 Level = Reading Level + Insertion Loss of LISN + Cable Loss  
 (All calculation were done by ESHS10 EMI test receiver.)
- 7.6 Result : **PASSED**

8 CONDUCTED POWER LINE TEST DATA (PAGE 1)

HomeTek EMC LAB. TEL :86-769-85303005 , 886-2-22608375

11 Dec 2007 08:44

CONDUCTED EMISSIONS

EUT: HS04  
 Manuf: 6K008  
 Op Cond: LINE  
 Operator: DORIS  
 Test Spec: FOR EN55022 CLASS B  
 Comment: 230V/50Hz  
 HDMI in 4 and HDMI out Mode  
 Result File: 6K0080011.dat

Prescan Measurement: Detectors: XPK / + AV  
 Meas Time: see scan settings  
 Subranges: 8  
 Avc Margin: 55 dB

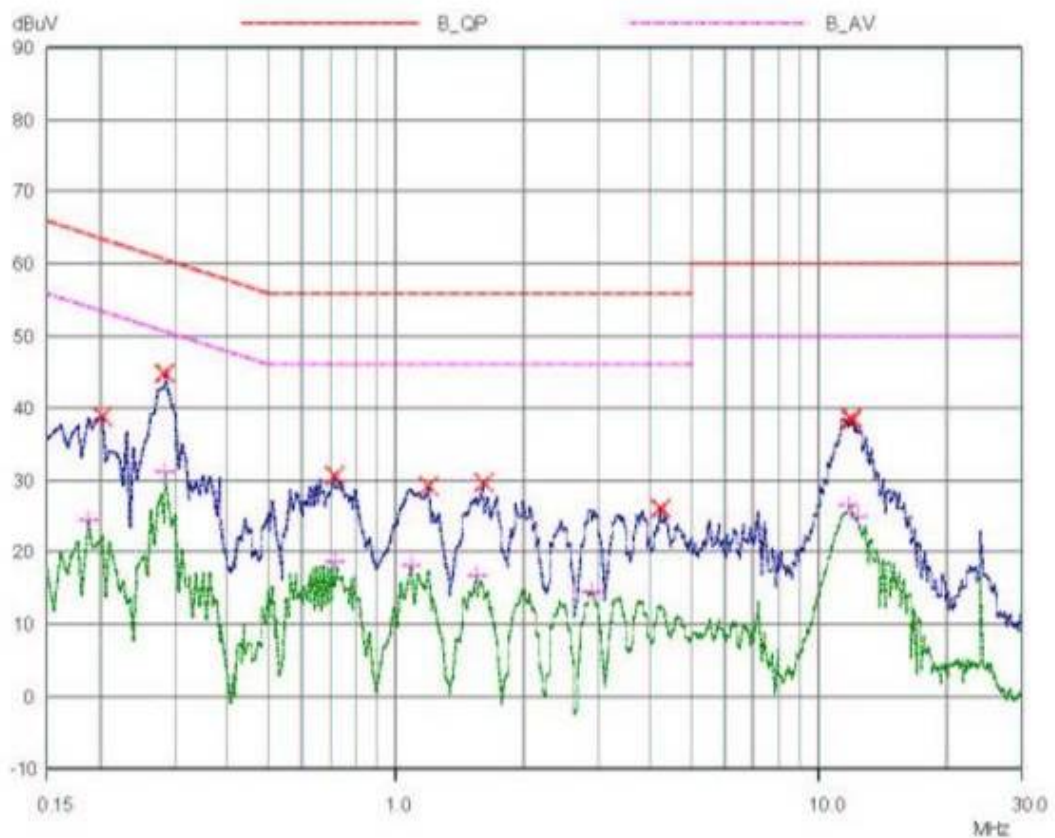

9 CONDUCTED POWER LINE TEST DATA (PAGE 2)

HomeTek EMC LAB. TEL :86-769-85303005 , 886-2-22608375

11 Dec 2007 08:44

CONDUCTED EMISSIONS

EUT: HS04  
 Manuf: 6K008  
 Op Cond: LINE  
 Operator: DCRIS  
 Test Spec: FOR EN55022 CLASS B  
 Comment: 230V/50Hz  
 HDMI in 4 and HDMI out Mode  
 Result File: 6K0080011.dat

Prescan Measurement:      Detectors: X PK / + AV  
 Meas Time: see scan settings  
 Subranges: 8  
 Acc Margin: 55 dB

Peak Search Results

Frequency MHz	PK Level dBuV	PK Limit dBuV	PK Delta dB
0.2	38.95	63.61	24.66
0.285	44.91	60.67	15.76
0.71	30.64	56.00	25.36
1.18	29.29	56.00	26.71
1.6	29.62	56.00	26.38
4.2	26.09	56.00	29.91
11.8	38.58	60.00	21.42
12.0	38.37	60.00	21.63

Frequency MHz	AV Level dBuV	AV Limit dBuV	AV Delta dB
0.185	24.42	54.26	29.84
0.285	31.15	50.67	19.52
0.71	18.61	46.00	27.39
1.08	18.08	46.00	27.92
1.54	16.67	46.00	29.33
2.86	14.50	46.00	31.50
11.72	26.50	50.00	23.50
12.3	25.03	50.00	24.97

\* limit exceeded

### 10 CONDUCTED POWER LINE TEST DATA (PAGE 3)

HomeTek EMC LAB. TEL :86-769-85303005 , 886-2-22608375

11 Dec 2007 09:03

#### CONDUCTED EMISSIONS

EUT: HS04  
 Manuf: 6K00B  
 Op Cond: NEUTRAL  
 Operator: DORIS  
 Test Spec: FOR EN55022 CLASS B  
 Comment: 230V/50Hz  
 HDMI in 4 and HDMI out Mode  
 Result File: 6K00B0012.dat

Prescan Measurement: Detectors: X PK / + AV  
 Meas Time: see scan settings  
 Subranges: 8  
 Acc Margin: 55 dB

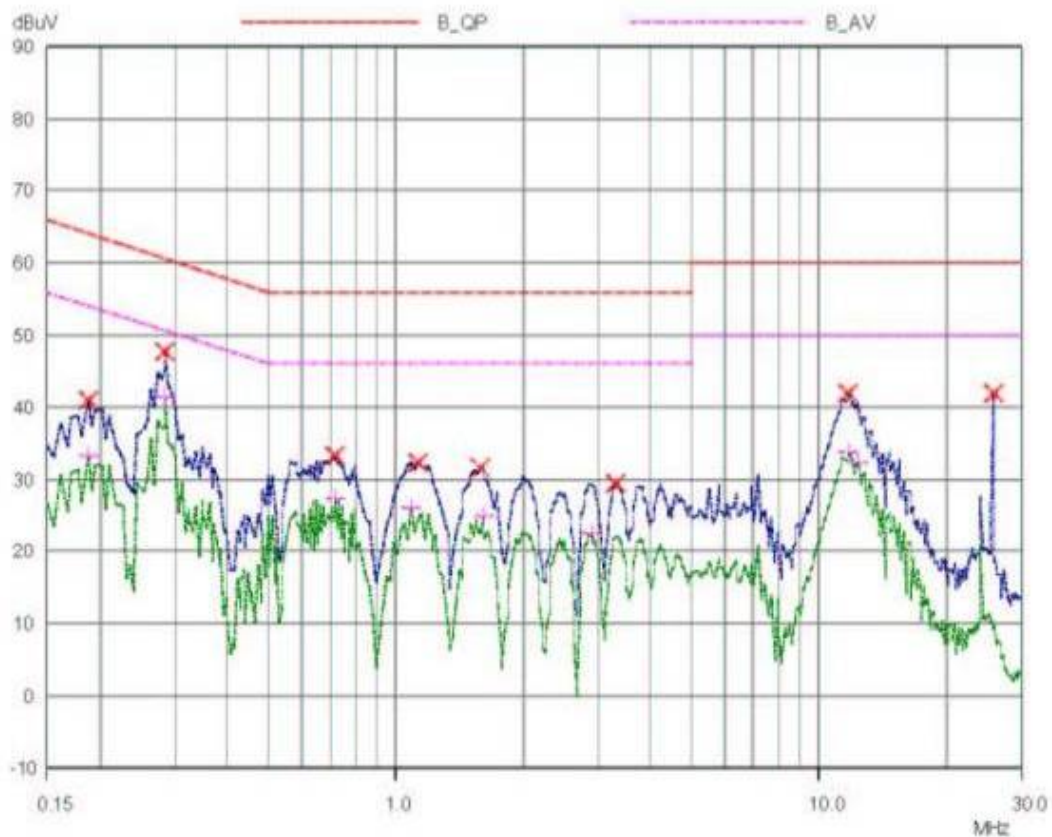



### 11 CONDUCTED POWER LINE TEST DATA (PAGE 4)

HomeTek EMC LAB. TEL :86-769-85303005 , 886-2-22608375

11 Dec 2007 09:03

#### CONDUCTED EMISSIONS

EUT: HS04  
 Manuf: 6K008  
 Op Cond: NEUTRAL  
 Operator: DORIS  
 Test Spec: FOR EN55022 CLASS B  
 Comment: 230V/50Hz  
 HDMI in 4 and HDMI out Mode  
 Result File: 6K0080012.dat

Prescan Measurement:      Detectors:      X PK / + AV  
 Meas Time:                    see scan settings  
 Subranges:                    8  
 Acc Margin:                    55 dB

#### Peak Search Results

Frequency MHz	PK Level dBuV	PK Limit dBuV	PK Delta dB
0.185	40.99	64.26	23.27
0.285	47.80	60.67	12.87
0.7165	33.27	56.00	22.73
1.12	32.48	56.00	23.52
1.58	31.67	56.00	24.33
3.32	29.46	56.00	26.54
11.76	42.03	60.00	17.97
25.74	42.03	60.00	17.97

Frequency MHz	AV Level dBuV	AV Limit dBuV	AV Delta dB
0.185	33.41	54.26	20.85
0.285	41.42	50.67	9.25
0.7165	27.31	46.00	18.69
1.08	26.20	46.00	19.80
1.6	24.89	46.00	21.11
2.9	22.50	46.00	23.50
11.76	33.73	50.00	16.27
12.3	32.40	50.00	17.60

\* limit exceeded

## RADIATED EMISSION TEST

### 1 TEST INSTRUMENTS & FACILITIES

The following test Instruments was used during the radiated emission test :

Item	Instruments /facilities	Specification	Manufacturer	Model # / S/N#	Date of Cal.
1	OPEN AREA TEST SITE	<input checked="" type="checkbox"/> OATS 3	HomeTek	N/A	DEC/2006
2	EMI TEST RECEIVER	20Hz ~ 5GHz	ROHED& SCHWARZ	ESBI 845636/007	DEC/2006
3	PRE-AMPLIFIER	9KHz ~1300MHz	HEWLETT PACKARD	8447D 1937A02095	DEC/2006
4	ANTENNA (BI-LOG)	30MHz ~ 2GHz	ANTENNA RESEACH	LPB2520/A 1095	MAR/2007
5	Attenuation	50Ω/6dB	JYE BAO	FAT-N(M-F) 001	DEC/2006
6	Cable	10m	SUHNER	RG214/U OS3-003	DEC/2006
7	Cable	14m	BELDEN	9913 OS3-001	DEC/2006
8	EMI 32 (software)	N/A	AUDIX	19991013-0923	N/A

Note : Items 1 ~ 7 were calibrated within period of 1 year.

## 2 TEST PROCEDURE

2.1 The EUT was test according to **EN55022**.

2.2 The radiated test was performed at HomeTek Lab's Open Site 3.

2.3 The frequency range from 30 MHz to 1 GHz, the measurement were made at 10 meters, with a BI-log antenna.

## 3 TEST SETUP

### 3.1 TEST SETUP OF OPEN SITE.

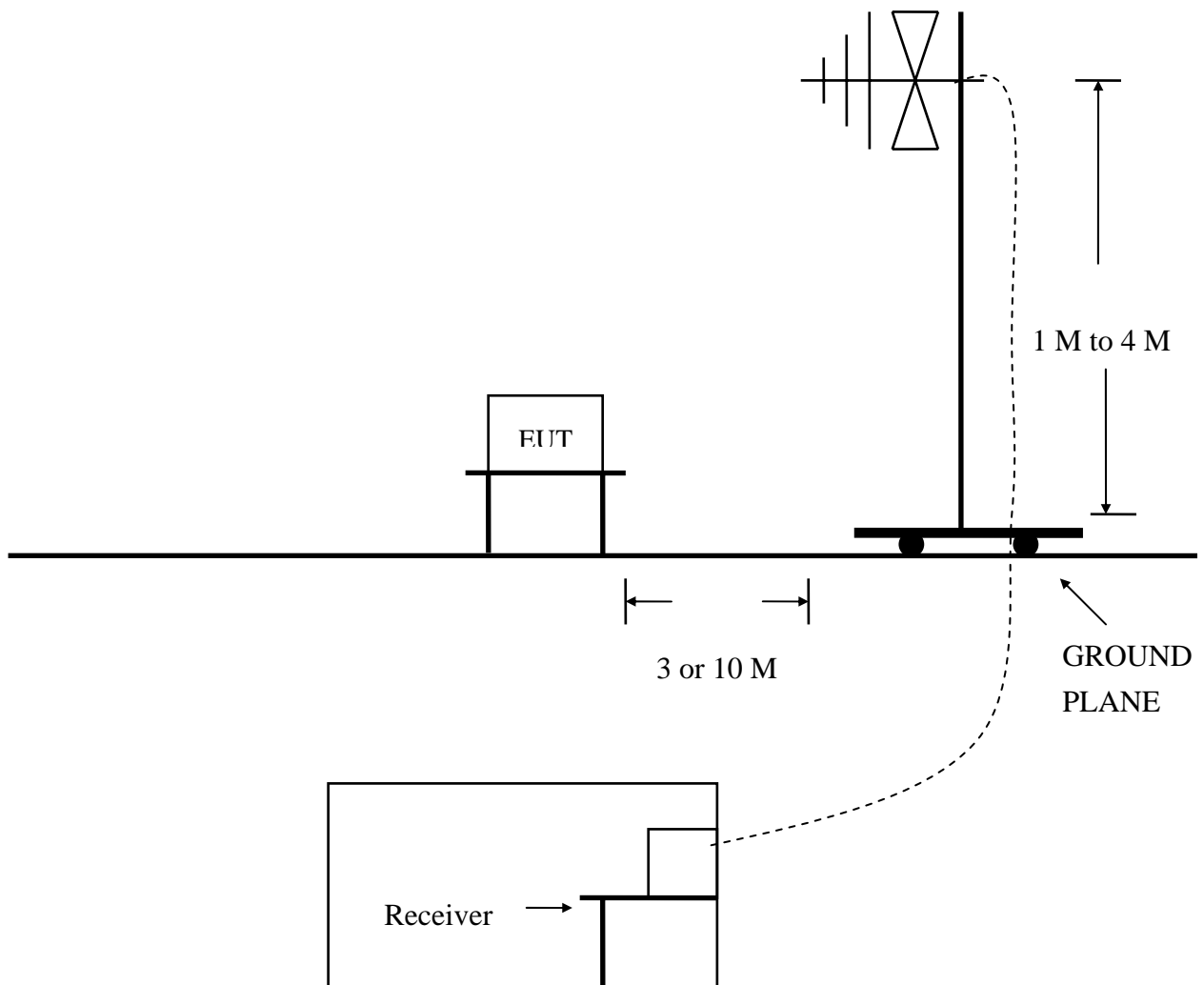

(Details for setup configuration, please refer to appendix A.)

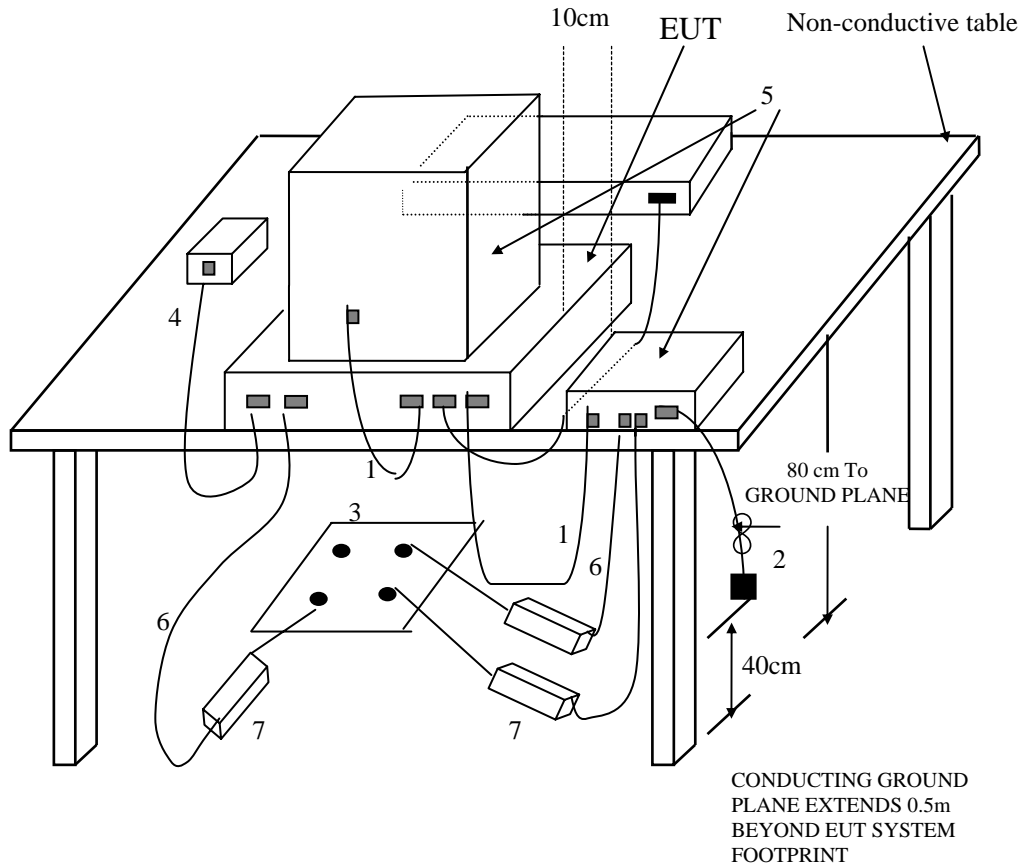

(Details for setup configuration, please refer to appendix A.)

#### LEGEND:

- 1.If cables, which hang closer than 40 cm to the horizontal metal ground plane cannot be shortened to the appropriate length, the excess shall be folded back and forth forming a bundle 30 cm to 40 cm long.
- 2.The end of I/O signal cables which are not connected to a peripheral may be terminated, if required for proper operation using correct terminating impedance.
- 3.Mains junction box(es) shall be flush with, and bonded directly to, the metal ground plane.  
NOTE if used, the AMN shall be installed under the horizontal metal ground plane.
- 4.Cables of hand-operated devices such as keyboards, mice, etc. shall be placed as for normal usage.
- 5.Peripherals shall be placed at a distance of 10 cm from each other and from the controller, except for the monitor which, if for an acceptable installation practice, shall be placed directly on top of the controller.
- 6.Mains cables, telephone lines or other connections to auxiliary equipment located outside the test area shall drape to the floor, be fitted with ferrite clamps or ferrite tubes placed on the floor at the point where the cable reaches the floor and then routed to the place where they leave the turntable. No extension cords shall be used to mains receptacle.
- 7.Ferrite clamps or ferrite tubes with similar characteristics (as defined in 10.4). No more than one cable per clamp.

### Test Configuration

#### Tabletop Equipment Radiated Measurement

4 CONFIGURATION OF THE EUT

Same as “Conducted Power Line test”, section 4

5 EUT OPERATING CONDITION

5.1 Same as “Conducted Power Line test”, section 5

5.2 The radiated emission in the frequency range from 30 MHz - 1000 MHz was test in a horizontal and vertical polarization at HomeTek Lab’s open site 3.

**5.3 The photos of radiated test configuration, please refer to appendix A.**

6 LIMIT OF RADIATED EMISSION CLASS B

Frequency (MHz)	Measurement Distance	Limit (dBuV/m)
30 - 230	10 (M)	30
230 - 1000	10 (M)	37

7 RESULT OF RADIATED EMISSION TEST

7.1 The frequency range from 30 MHz to 1 GHz was investigated.

7.2 All readings below or equal 1 GHz are quasi-peak or peak values with resolution bandwidth of 120 KHz.

7.3 The measurements were made at 10 meters of HomeTek Lab’s open site 3.

7.4 Temperature : 24.5 °C, Humidity : 49 % RH.

7.5 Deviation form the test standards and rules : None.

7.6 The radiated emission result were gained by the following method :

Level = Reading Level + Probe Factor (Antenna Factor) + Cable Loss – Preamp Factor  
 Over Limit = Level – Limit Line

7.7 Result : **PASSED**

8 RADIATED EMISSION TEST DATA (PAGE 1)



HomeTek Technology Inc.

HomeTek Technology Inc.  
 Tel:02-22608375  
 Fax:02-22748013

Data#: 6 File#: 6K008.EMI

Date: 2007-12-12 Time: 16:34:23

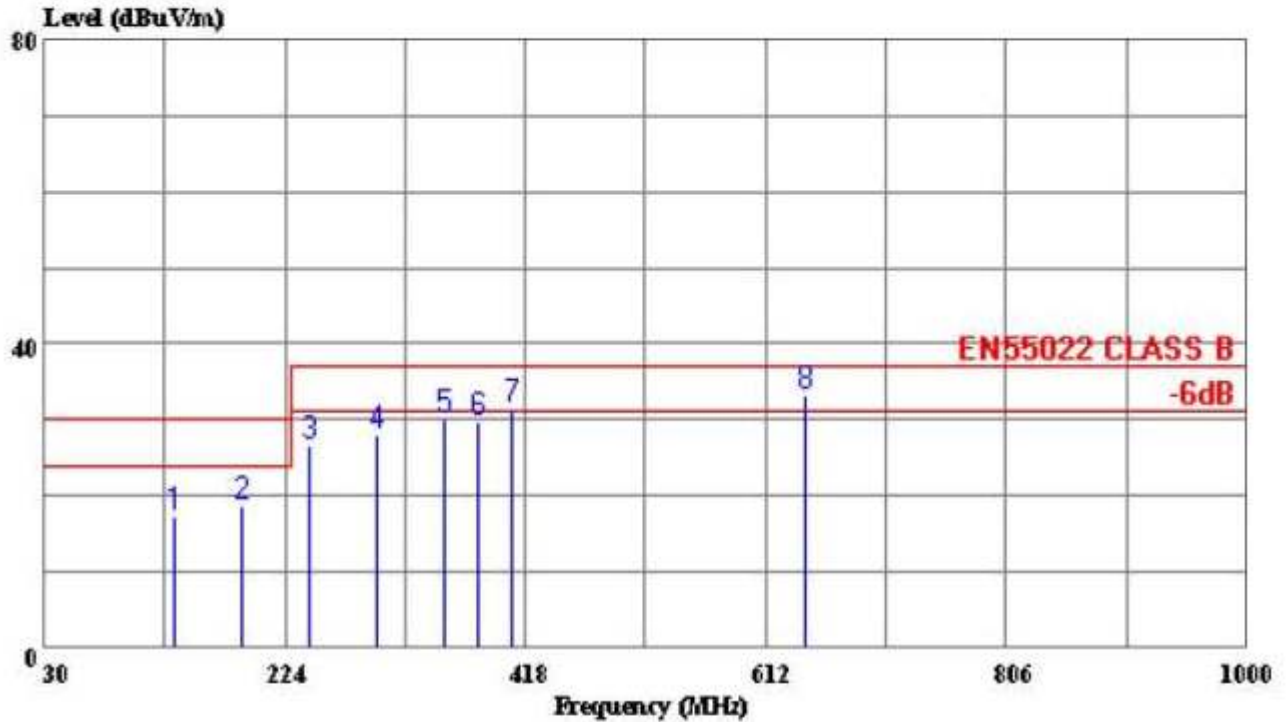

Trace:

Ref Trace:

Condition: EN55022 CLASS B 10m LPB-250/A-031028 HORIZONTAL  
 out : HS04  
 power: 230V/50Hz  
 memo : HDMI in 4 and HDMI out Mode

Page: 1

	Freq	Level	Limit	Over	Read		Remark
	MHz	dBuV/m	dBuV/m	Limit	Level	Factor	
				dB	dBuV	dB	
1	135.730	17.32	30.00	-12.68	38.40	-21.08	Peak
2	189.080	18.67	30.00	-11.33	38.60	-19.93	Peak
3	244.370	26.54	37.00	-10.46	42.90	-16.36	Peak
4	298.690	28.04	37.00	-8.96	42.60	-14.56	Peak
5	353.010	30.29	37.00	-6.71	41.20	-10.91	Peak
6	379.200	29.77	37.00	-7.23	38.40	-8.63	Peak
7	407.520	31.59	37.00	-5.41	42.80	-11.21	QP
8	643.640	33.11	37.00	-3.89	38.50	-5.39	QP

9 RADIATED EMISSION TEST DATA (PAGE 2)



HomeTek Technology Inc.

HomeTek Technology Inc.  
Tel:02-22608375  
Fax:02-22748013

Data#: 5 File#: 6K008.EMI

Date: 2007-12-12 Time: 15:40:04

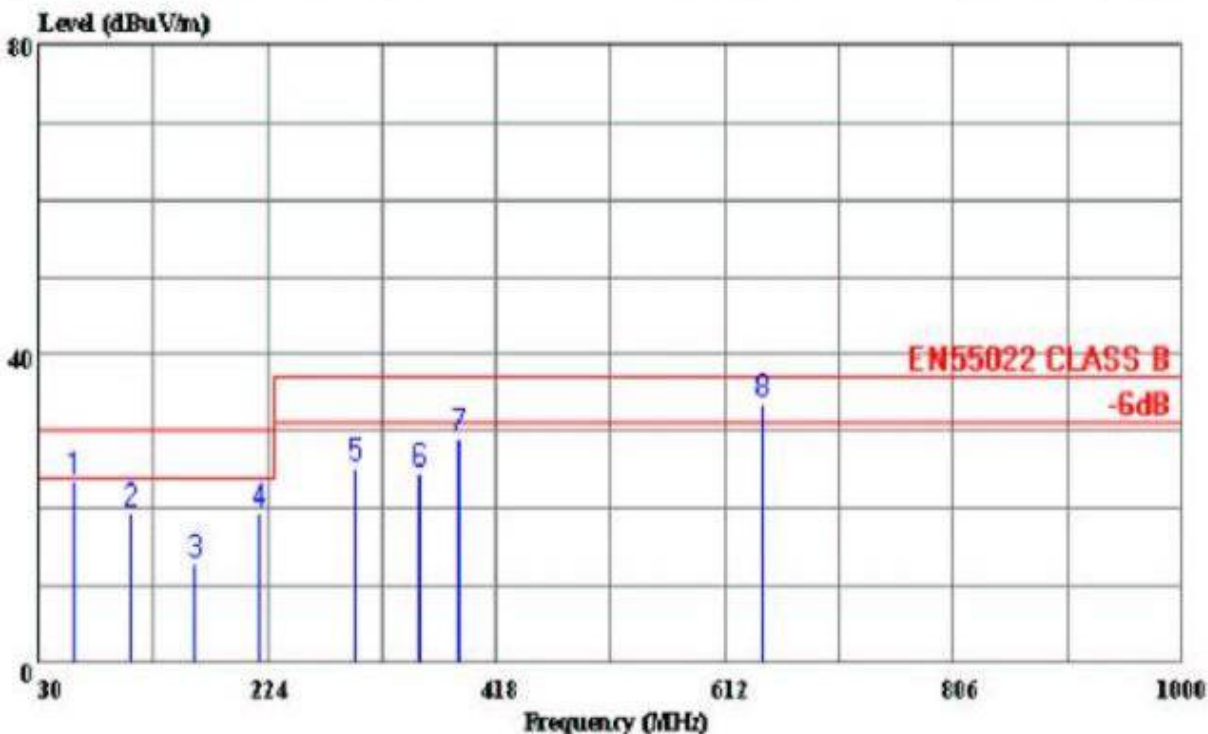

Trace:

Ref Trace:

Condition: EN55022 CLASS B 10m LPB-250/A-031028 VERTICAL  
 eut : HS04  
 power: 230V/50Hz  
 memo : HDMI in 4 and HDMI out Mode

Page: 1

	Freq	Level	Limit	Over	Read	Factor	Remark
	MHz	dBuV/m	dBuV/m	dB	dBuV	dB	
1	60.070	23.43	30.00	-6.57	39.10	-15.67	Peak
2	107.600	19.53	30.00	-10.47	35.60	-16.07	QP
3	162.890	12.89	30.00	-17.11	35.10	-22.21	Peak
4	216.240	19.45	30.00	-10.55	32.40	-12.95	Peak
5	297.720	25.31	37.00	-11.69	34.40	-9.09	Peak
6	352.040	24.76	37.00	-12.24	35.20	-10.44	Peak
7	386.960	28.93	37.00	-8.08	39.00	-10.08	Peak
8	643.860	33.58	37.00	-3.42	42.10	-8.52	QP

## HARMONICS TEST

### 1 TEST INSTRUMENTS & FACILITIES

Instruments/ facilities	Manufacturer	Model # Serial #	Date of Cal.
POWER FREQUENCY TEST SYSTEM	HAEFELY	PHF555 080419-12	JAN/2007
CONTROL PC	KB TECH	KB P586/133	N/A

Note : Item 1 were calibrated with two years and verified before testing.

### 2 TEST PROCEDURE

According to EN 61000-3-2 (2006) Class A

### 3 TEST SETUP

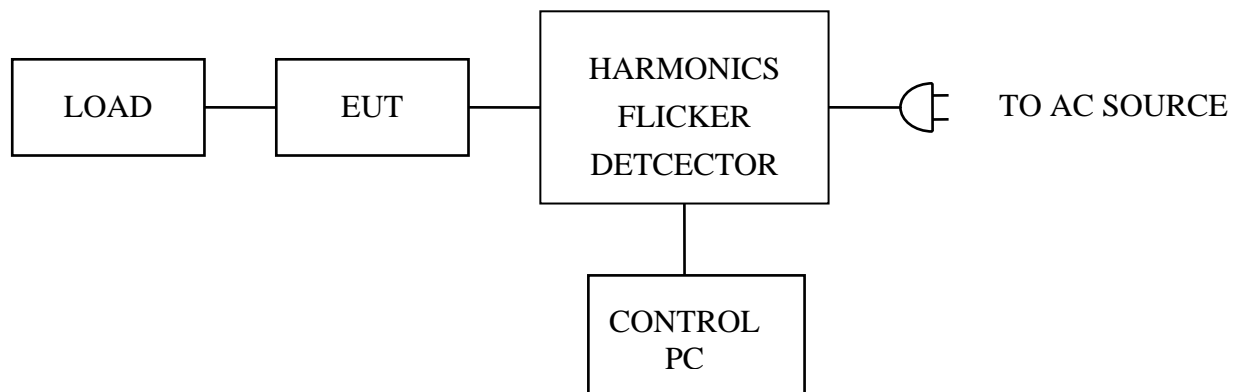

(Details for setup configuration, please refer to appendix A.)

### 4 CONFIGURATION OF THE EUT

Same as “Conducted Power Line test”, section 4

### 5 OPERATION CONDITION OF EUT

Same as “Conducted Power Line test”, section 5

### 6 TEST DATA & LIMIT

6.1 Temperature : 23.8 °C

6.2 Humidity : 48 % RH



7 HARMONICS TEST DATA (PAGE 1~2)

-----  
EN 61000-3-2 TEST REPORT 2007/12/11 6:55 PM  
-----

Unit : Multimedia AV Switcher  
Serial No. : HS04  
Remarks : HDMI in 4 and HDMI out Mode  
Operator : DORIS  
=====

TEST SETUP  
-----

Test Freq.: 50.00 Hz. Test Voltage: 230.0 vac  
Waveform : SINE Test Time: 15 min.  
Classification : CLASS A Test Type: STEADY-STATE  
Prog. Zo Enabled: YES Prog. Zo: 0.000  
Motor Driven with Phase Angle Control: NO  
Impedance selected: DIRECT  
Synthetic R+L Enabled: NO  
Resistance: 0.400 Ohms Inductance: 795.775 uH

Result: PASS

Harmonic Current Results

Harmonic Voltage Results

Hn	AMPS	LO Limit	HI Limit	Result	%Fund.	Limit	Result
0	0.000	0.000	0.000	PASS	0.000	NaN	PASS
1	0.047	NaN	NaN	PASS	100.000	100.001	PASS
2	0.002	1.620	1.620	PASS	0.006	0.200	PASS
3	0.022	3.450	3.450	PASS	0.007	0.900	PASS
4	0.001	0.645	0.645	PASS	0.001	0.200	PASS
5	0.019	1.710	1.710	PASS	0.007	0.400	PASS
6	0.000	0.450	0.450	PASS	0.001	0.200	PASS
7	0.003	1.155	1.155	PASS	0.002	0.300	PASS
8	0.000	0.345	0.345	PASS	0.001	0.200	PASS



HomeTek Technology Inc.

9	0.002	0.600	0.600	PASS	0.002	0.200	PASS
10	0.000	0.276	0.276	PASS	0.001	0.200	PASS
11	0.001	0.495	0.495	PASS	0.003	0.100	PASS
12	0.000	0.230	0.230	PASS	0.001	0.100	PASS
13	0.000	0.315	0.315	PASS	0.003	0.100	PASS
14	0.000	0.197	0.197	PASS	0.001	0.100	PASS
15	0.001	0.225	0.225	PASS	0.001	0.100	PASS
16	0.000	0.172	0.172	PASS	0.001	0.100	PASS
17	0.000	0.199	0.199	PASS	0.001	0.100	PASS
18	0.000	0.153	0.153	PASS	0.001	0.100	PASS
19	0.000	0.178	0.178	PASS	0.002	0.100	PASS
20	0.000	0.138	0.138	PASS	0.001	0.100	PASS
21	0.000	0.161	0.161	PASS	0.002	0.100	PASS
22	0.000	0.125	0.125	PASS	0.001	0.100	PASS
23	0.000	0.147	0.147	PASS	0.003	0.100	PASS
24	0.000	0.115	0.115	PASS	0.001	0.100	PASS
25	0.000	0.135	0.135	PASS	0.003	0.100	PASS
26	0.000	0.106	0.106	PASS	0.001	0.100	PASS
27	0.000	0.125	0.125	PASS	0.003	0.100	PASS
28	0.000	0.099	0.099	PASS	0.001	0.100	PASS
29	0.000	0.116	0.116	PASS	0.001	0.100	PASS
30	0.000	0.092	0.092	PASS	0.001	0.100	PASS
31	0.000	0.109	0.109	PASS	0.002	0.100	PASS
32	0.000	0.086	0.086	PASS	0.001	0.100	PASS
33	0.000	0.102	0.102	PASS	0.003	0.100	PASS
34	0.000	0.081	0.081	PASS	0.001	0.100	PASS
35	0.000	0.096	0.096	PASS	0.002	0.100	PASS
36	0.000	0.077	0.077	PASS	0.001	0.100	PASS
37	0.000	0.091	0.091	PASS	0.001	0.100	PASS
38	0.000	0.073	0.073	PASS	0.000	0.100	PASS
39	0.000	0.087	0.087	PASS	0.002	0.100	PASS
40	0.000	0.069	0.069	PASS	0.001	0.100	PASS

PAGE 2  
END OF REPORT

## VOLTAGE FLUCTUATIONS TEST

### 1 TEST INSTRUMENTS & FACILITIES

Instruments/ facilities	Manufacturer	Model # Serial #	Date of Cal.
POWER FREQUENCY TEST SYSTEM	HAEFELY	PHF555 080419-12	JAN/2007
CONTROL PC	KB TECH	KB P586/133	N/A

Note : Item 1 were calibrated with two years and verified before testing.

### 2 TEST PROCEDURE

According to EN 61000-3-3 (1995) + A1 (2001) + A2 (2005)

### 3 TEST SETUP

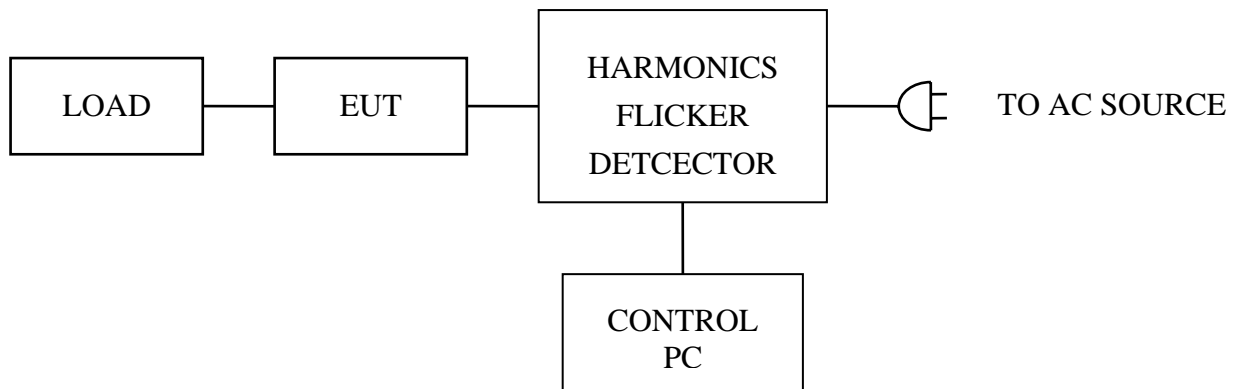

(Details for setup configuration, please refer to appendix A.)

### 4 CONFIGURATION OF THE EUT

Same as “Conducted Power Line test”, section 4

### 5 OPERATION CONDITION OF EUT

Same as “Conducted Power Line test”, section 5

### 6 TEST DATA & LIMIT

6.1 Temperature : 23.8 °C

6.2 Humidity : 48 % RH



7 VOLTAGE FLUCTUATIONS TEST DATA (PAGE 1)

-----  
EN 61000-3-3 TEST REPORT 2007/12/11 7:36 PM  
-----

Unit : Multimedia AV Switcher  
Serial No. : HS04  
Remarks : HDMI in 4 and HDMI out Mode  
Operator : DORIS  
=====

TEST SETUP  
-----

Test Freq.: 50.00 Hz. Test Voltage: 230.0 vac  
Waveform : SINE  
Test Time: 15 min. Tshort: 15 min.  
Prog. Zo Enabled: YES Prog. Zo: 0.000  
Voltage Change less than once per Hour: NO  
Impedance selected: DIRECT  
Synthetic R+L Enabled: NO  
Resistance: 0.400 Ohms Inductance: 795.775 uH

TEST DATA  
-----

Result: PASS

	EUT Data	Limit	Result	Test Enabled
Pst max	0.010	1.00	PASS	true
Plt max	0.010	0.65	PASS	true
dc %	0.00	3.00	PASS	true
dmax %	0.00	4.00	PASS	true
d(t) sec.	0.00	0.20	PASS	true

Power Source Data

Source Pst max	0.019	0.400	PASS	true
% THD	0.02	3.00	PASS	true

PAGE 1  
END OF REPORT

## ELECTROSTATIC DISCHARGE IMMUNITY TEST (ESD)

### 1 TEST INSTRUMENTS & FACILITIES

Instruments/ Facilities	Manufacturer	Model # Serial #	Data Of Cal.
ESD TESTER	NOISEKEN	ESS-2002 ESS05033971	DEC/2006
VCP	HOMETEK	--	--

### 2 TEST PROCEDURE

According to **IEC 61000-4-2 (2001)**

According to **EN 55024 (1998) + A1 (2001) + A2 (2003)**

### 3 TEST SETUP

TABLE SIZE

160L X 80W X 80H cm

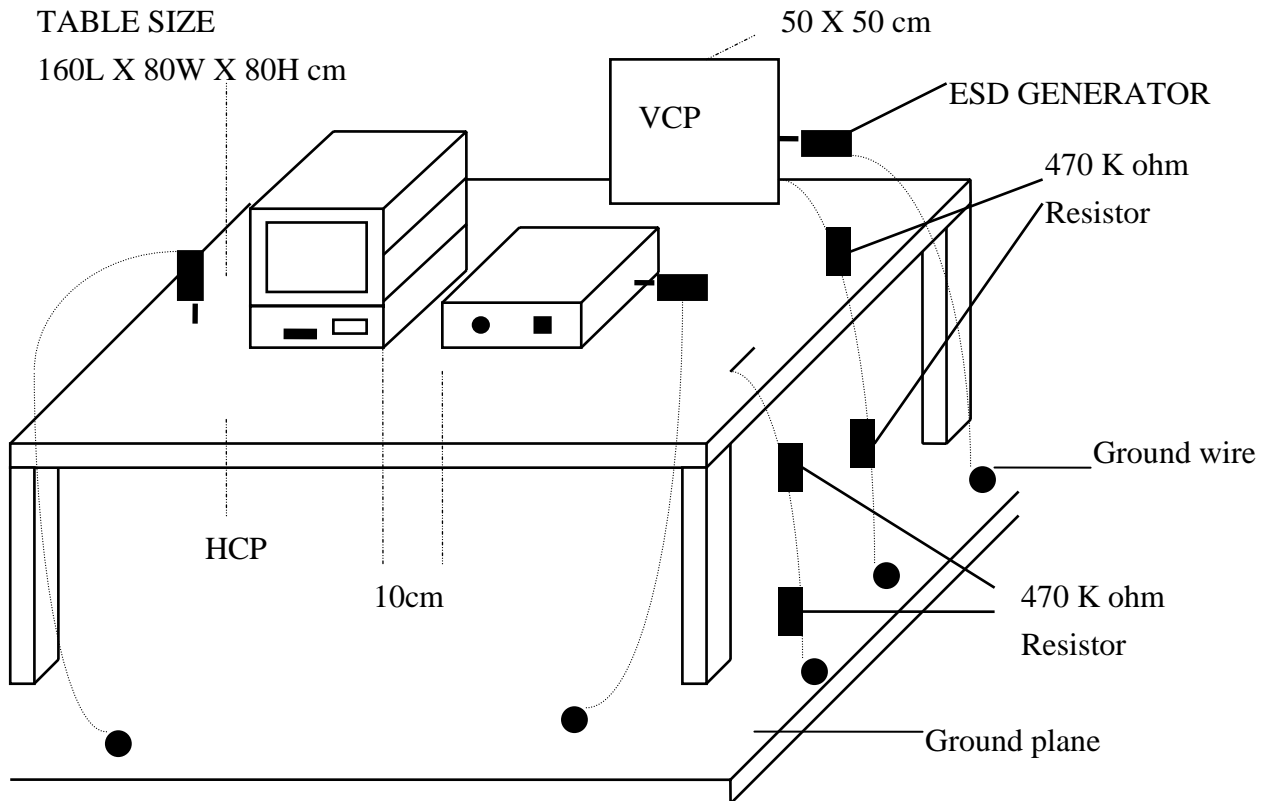

(Details for setup configuration, please refer to appendix A.)

#### 4 CONFIGURATION OF THE EUT

Same as “Conducted Power Line test”, section 4

#### 7 EUT OPERATION CONDITION

Same as “Conducted Power Line test”, section 5

#### 7 TEST CONDITION

##### 6.1 Test Level :

(A)  $\pm 2$ ,  $\pm 4$ ,  $\pm 8$ KV for air discharge.

(B)  $\pm 2$ ,  $\pm 4$ KV for contact discharge.

6.2 Number of test : 10 Discharges / Test point / Polarity / Level

Particular requirements : at least 200 discharges, 100 each at negative and positive polarity, at a minimum of four test points.

6.3 Time between test : 1 sec.

6.4 Temperature : 24.5 °C

6.5 Humidity : 50 % RH.

#### 7 PERFORMANCE CRITERIA

- A. The apparatus shall continue to operate as intended during and after the test. No degradation of performance or loss of function is allowed below a performance level specified by the manufacturer, when the apparatus is used as intended.
- B. The apparatus shall continue to operate as intended after the test. No degradation of performance or loss of function is allowed below a performance level specified by the manufacturer, when the apparatus is used as intended. The performance level may be replaced by a permissible loss of performance. During the test, degradation of performance is however allowed.
- C. Temporary loss of function is allowed, provided the function is self-recoverable or can be restored by the operation of the controls.

## 8 TEST RESULT

Test Point	Air Discharge	Contact Discharge	Performance Criteria	Result
HCP	---	$\pm 2, \pm 4KV$	B	<b>PASSED</b>
VCP	---	$\pm 2, \pm 4KV$	B	<b>PASSED</b>
CASE	$\pm 2, \pm 4, \pm 8KV$	$\pm 2, \pm 4KV$	B	<b>PASSED</b>
I/O PORTS	$\pm 2, \pm 4, \pm 8KV$	$\pm 2, \pm 4KV$	B	<b>PASSED</b>
LED	$\pm 2, \pm 4, \pm 8KV$	$\pm 2, \pm 4KV$	B	<b>PASSED</b>
BUTTON	$\pm 2, \pm 4, \pm 8KV$	$\pm 2, \pm 4KV$	B	<b>PASSED</b>
SCREWS	$\pm 2, \pm 4, \pm 8KV$	$\pm 2, \pm 4KV$	B	<b>PASSED</b>
DC SOCKET	$\pm 2, \pm 4, \pm 8KV$	$\pm 2, \pm 4KV$	B	<b>PASSED</b>

## RADIO FREQUENCY ELECTROMAGNETIC FIELD IMMUNITY TEST (RS)

### 1 TEST INSTRUMENTS & FACILITIES

Item	Instruments Facilities	Manufacturer	Model # Serial #	Data Of Cal.
1	SIGNAL GENERATOR	MARCONI INSTRUMENTS	2022D 119229/010	DEC/2006
2	AMPLIFIER	KALMUS	7100LC-CE 748813-2	DEC/2006
3	FIELD SENSOR	AMPLIFIER RESEARCH	FP2000	DEC/2006
4	FIELD MONITOR	AMPLIFIER RESEARCH	FM2000	DEC/2006
5	RF VOLTMETER	BOONTON	9200C 354201AA	DEC/2006
6	RF PROBE	BOONTON	952001B 37082	DEC/2006
7	DIRECTION COUPLER	WERLATON	G2630 4795	DEC/2006
8	ANTENNA	EMCO	3810/2NM S/N:9701-1763	DEC/2006
9	CONTROL PC	KB TECH	KB P586/133	--

Note : Items 3 ~ 4 were calibrated with two years and verified before testing.

### 2 TEST PROCEDURE

According to **IEC 61000-4-3 (2002)**

According to **EN 55024 (1998) + A1 (2001) + A2 (2003)**

### 3 TEST SETUP

#### FERRITE TILE

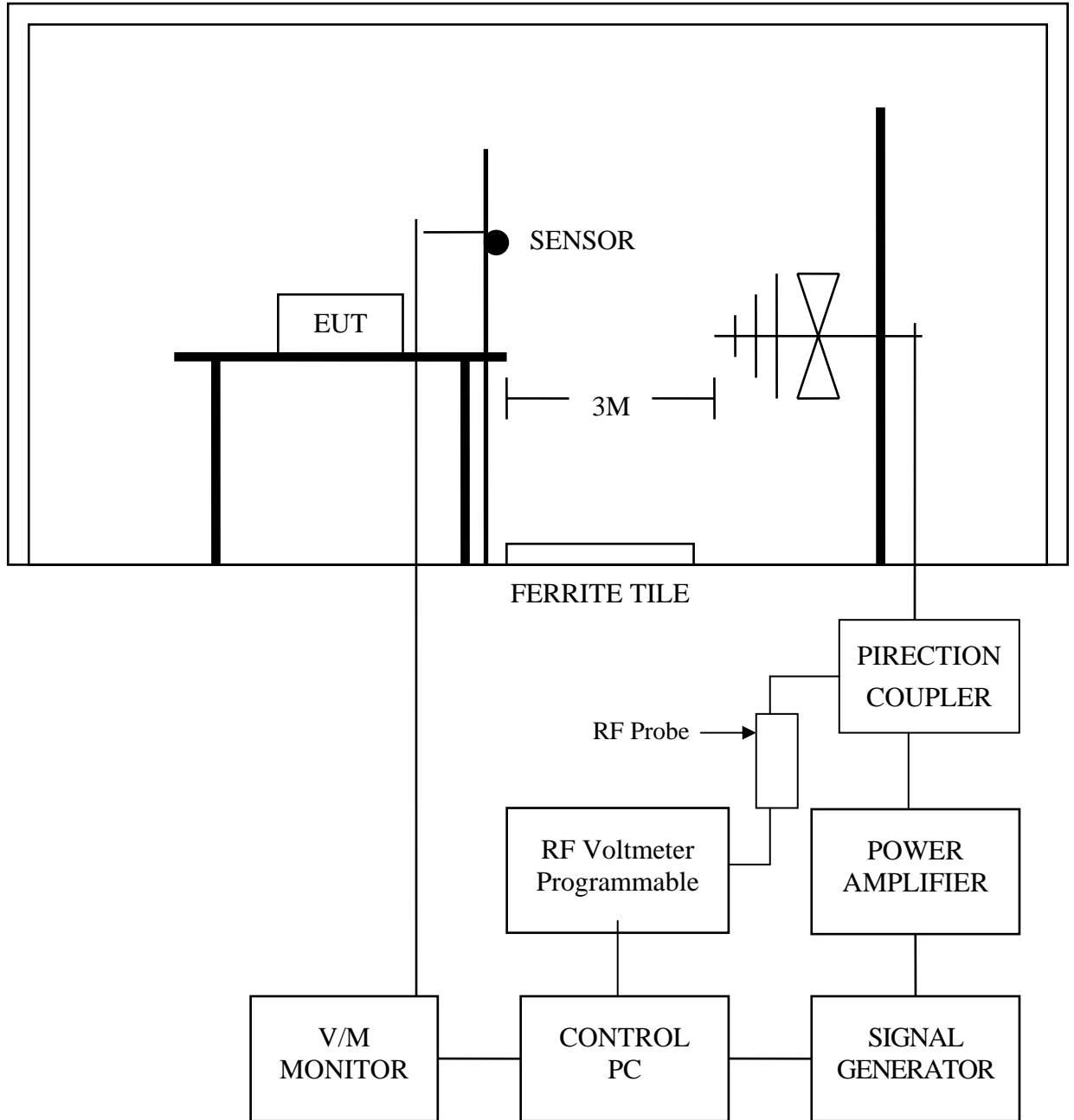

#### 3.1 Chamber Size :

12M x 5M x 5M

(Details for setup configuration, please refer to appendix A.)

#### 4 CONFIGURATION OF THE EUT

Same as “Conducted Power Line test”, section 4

#### 5 OPERATION CONDITION OF EUT

Same as “Conducted Power Line test”, section 5

#### 6 TEST CONDITION

6.1 Frequency Range : 80 MHz ~ 1000 MHz

(Frequency Range : 1.4 GHz ~ 2.0 GHz is not applicable for EN55024:1998+A1:2001+A2:2003)

6.2 Filed Strength : 3 V / M (1KHz 80% Modulation)

6.3 Frequency Step : 1 %, 3 sec. / each step size

6.4 Antenna Polarity : HORIZONTAL & VERTICAL

6.5 The four sides of EUT are tested  
(FRONT, REAR, RIGHT, LEFT)

6.6 Temperature : 23.8 °C

6.7 Humidity : 51 % RH

#### 7 PERFORMANCE CRITERIA

- A. The apparatus shall continue to operate as intended during and after the test. No degradation of performance or loss of function is allowed below a performance level specified by the manufacturer, when the apparatus is used as intended.
- B. The apparatus shall continue to operate as intended after the test. No degradation of performance or loss of function is allowed below a performance level specified by the manufacturer, when the apparatus is used as intended. The performance level may be replaced by a permissible loss of performance. During the test, degradation of performance is however allowed.
- C. Temporary loss of function is allowed, provided the function is self-recoverable or can be restored by the operation of the controls.

8 TEST RESULT

ANT SIDE	HORIZONTAL	VERTICAL	RESULT
FRONT	A	A	PASSED
REAR	A	A	PASSED
RIGHT	A	A	PASSED
LEFT	A	A	PASSED

## ELECTRICAL FAST TRANSIENT/BURST IMMUNITY TEST (EFT)

### 1 TEST INSTRUMENTS & FACILITIES

Instruments/ Facilities	Manufacturer	Model # Serial #	Data Of Cal.
BURST-TESTER	EMC PARTNER	TRANSIENT-1000 TRA1000-317	DEC/2006
CONTROL PC	KB TECH	KB P586/133	--

### 2 TEST PROCEDURE

According to **IEC 61000-4-4 (2004)**

According to **EN 55024 (1998) + A1 (2001) + A2 (2003)**

### 3 TEST SETUP

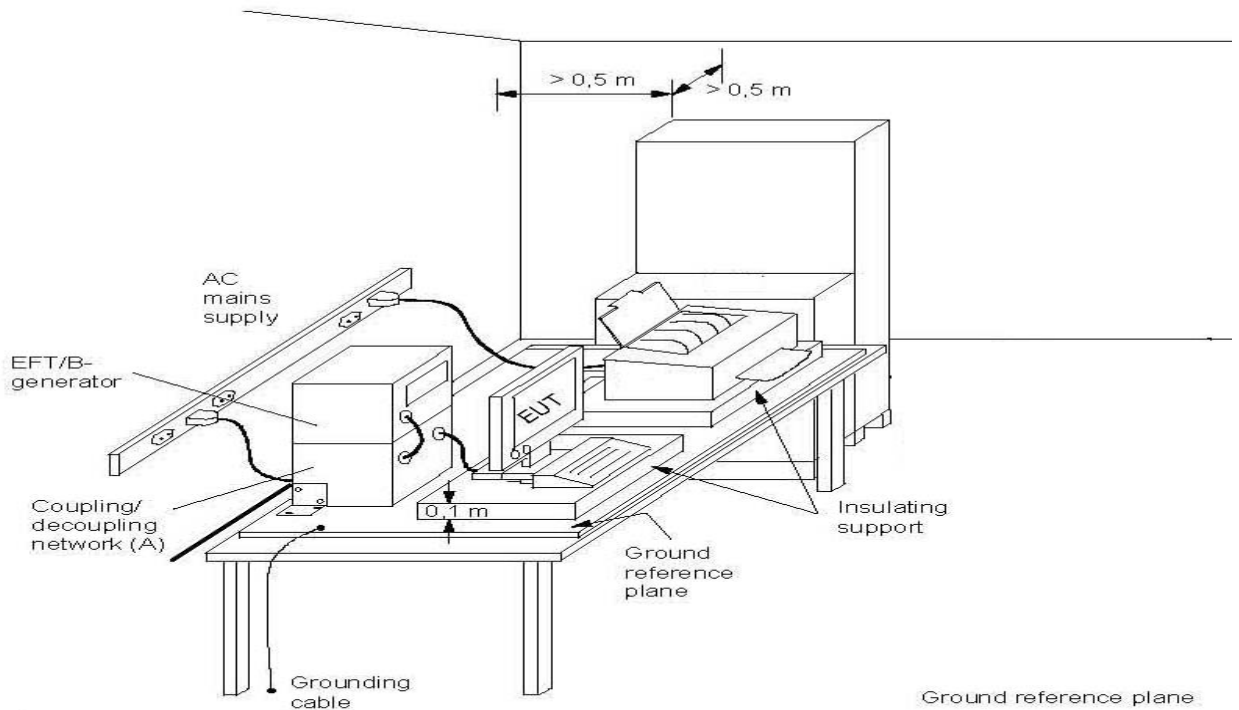

(Details for setup configuration, please refer to appendix A.)

Note: length between clamp and the EUT to be tested (should be  $0.5 \text{ m} \pm 0.05 \text{ m}$ )

(A) location for supply line coupling

(B) location for signal line coupling

#### 4 CONFIGURATION OF THE EUT

Same as “Conducted Power Line test”, section 4

#### 5 OPERATION CONDITION OF EUT

Same as “Conducted Power Line test”, section 5

#### 6 TEST CONDITION

6.1 Pulse Rise time & Duration : 5 nS / 50 nS

6.2 Pulse Repetition : 5 kHz

6.3 Polarity : POSITIVE / NEGATIVE

6.4 Test Voltage :  $\pm 0.5\text{KV}$ ,  $\pm 1\text{KV}$

6.5 Coupling of power line :

L, N, L+N

6.6 Temperature : 24.1 °C

6.7 Humidity : 49 % RH

#### 7 PERFORMANCE CRITERIA

- A. The apparatus shall continue to operate as intended during and after the test. No degradation of performance or loss of function is allowed below a performance level specified by the manufacturer, when the apparatus is used as intended.
- B. The apparatus shall continue to operate as intended after the test. No degradation of performance or loss of function is allowed below a performance level specified by the manufacturer, when the apparatus is used as intended. The performance level may be replaced by a permissible loss of performance. During the test, degradation of performance is however allowed.
- C. Temporary loss of function is allowed, provided the function is self-recoverable or can be restored by the operation of the controls.

## 8 TEST RESULT

TEST VOLTAGE	L	N	L+N
±0.5KV	A	A	A
±1KV	A	A	A

8.1 Model : HS04

8.2 Test Mode : HDMI in 4 and HDMI out Mode

8.3 Final Result : PASSED

8.4 Remark :

## SURGE IMMUNITY TEST

### 1 TEST INSTRUMENTS & FACILITIES

Instruments/ Facilities	Manufacturer	Model # Serial #	Data Of Cal.
BURST-TESTER	EMC PARTNER	TRANSIENT-1000 TRA1000-317	DEC/2006
CONTROL PC	KB TECH	KB P586/133	--

### 2 TEST PROCEDURE

According To **IEC 61000-4-5 (2001)**

According To **EN 55024 (1998) + A1 (2001) + A2 (2003)**

### 3 TEST SETUP

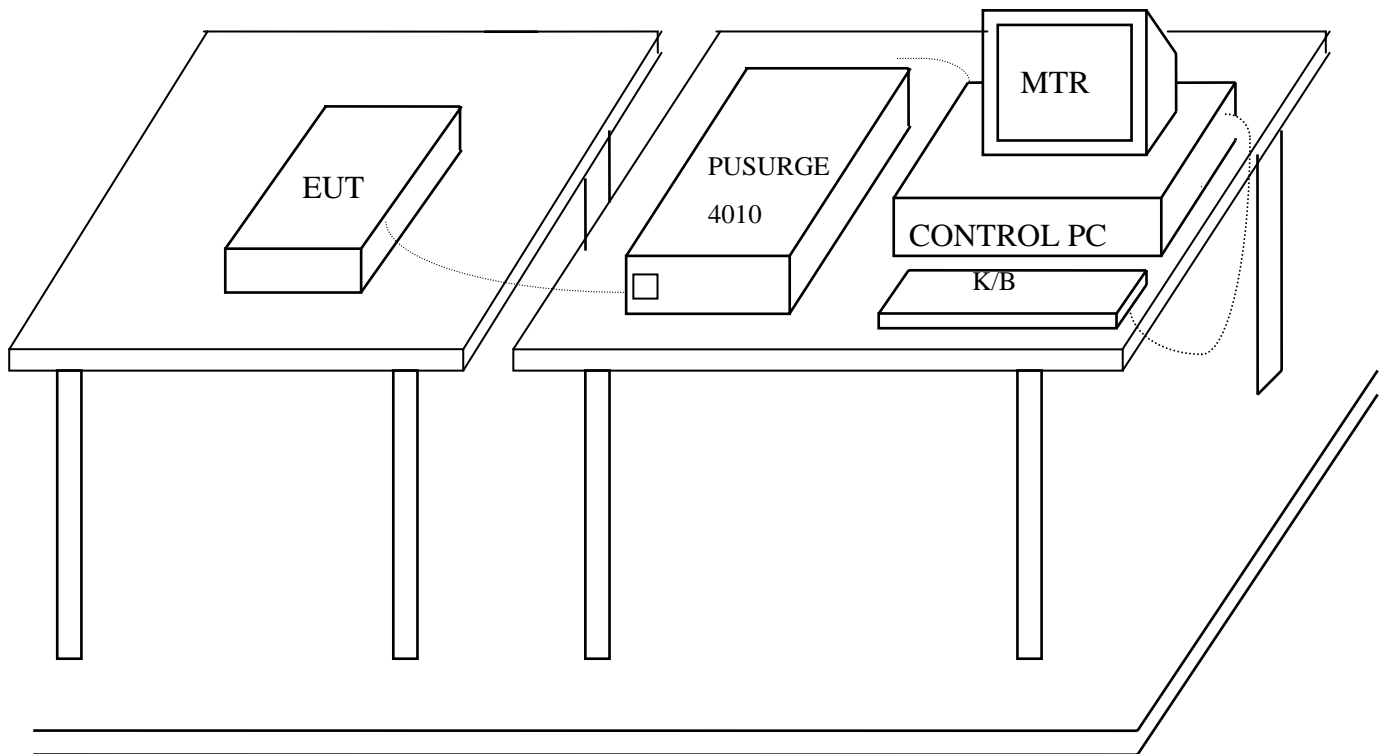

**GROUND PLANE**

(Details for setup configuration, please refer to appendix A.)

#### 4 TEST LEVELS

- Input and Output AC Power Ports.
- DC Input and DC Output Power Ports.

Environmental Phenomena	Test Specification		Units	Performance Criteria
	AC	DC		
Surges	1.2 / 50 (8/20)		Tr /Th us	
Line to Line	±1	±0.5	KV (Charge Voltage)	B

#### 5 CONFIGURATION OF THE EUT

Same as “Conducted Power Line test”, section 4

#### 6 EUT OPERATION CONDITION

Same as “Conducted Power Line test”, section 5

#### 7 CONDITIONS DURING TESTING

7.1 Coupling of power line :

(A) Line to Line            ±1KV (AC)   or ±0.5KV (DC)

7.2 Polarity : POSITIVE / NEGATIVE

7.3 Phase shifting in a range between 0° to 360°

7.4 Repletion rate at least 1 per min

7.5 Temperature :   23.6   °C (15°C ~ 35°C)

Humidity :   48   % RH.(10 % ~ 75%)

## 8 PERFORMANCE CRITERIA

- A. The apparatus shall continue to operate as intended during and after the test. No degradation of performance or loss of function is allowed below a performance level specified by the manufacturer, when the apparatus is used as intended.
- B. The apparatus shall continue to operate as intended after the test. No degradation of performance or loss of function is allowed below a performance level specified by the manufacturer, when the apparatus is used as intended. The performance level may be replaced by a permissible loss of performance. During the test, degradation of performance is however allowed.
- C. Temporary loss of function is allowed, provided the function is self-recoverable or can be restored by the operation of the controls.

## 9 TEST RESULT

Environmental Phenomena	Test Specification	Units	Performance
Line to Line	$\pm 1$	KV (Charge Voltage)	A

9.1 Model : HS04

9.2 Test Mode : HDMI in 4 and HDMI out Mode

9.3 Final Result : PASSED

9.4 Remark :

## IMMUNITY TEST TO CS CONDUCTED DISTURBANCE

### 1 TEST INSTRUMENTS & FACILITIES

Instruments/ Facilities	Manufacturer	Model # Serial #	Date Of Cal.
SIGNAL GENERATOR	MARCONI INSTRUMENTS	2022D 119229/010	DEC/2006
AMPLIFIER	KALMUS	7100LC-CE	DEC/2006
RF VOLTMETER	BOONTON	9200C 354201AA	DEC/2006
RF PROBE	BOONTON	952001B 37082	DEC/2006
DIRECTION COUPLER	WERLATON	G2630 4795	DEC/2006
COUPLING DECOUPLING NETWORK	ELECTRO-METRICS	EM-7801 103	DEC/2006
CONTROL PC	KB TECH	KB P586/133	--

### 2 TEST PROCEDURE

According To **IEC 61000-4-6 (2003) + A1 (2004)**

According To **EN 55024 (1998) + A1 (2001) + A2 (2003)**

### 3 TEST SETUP

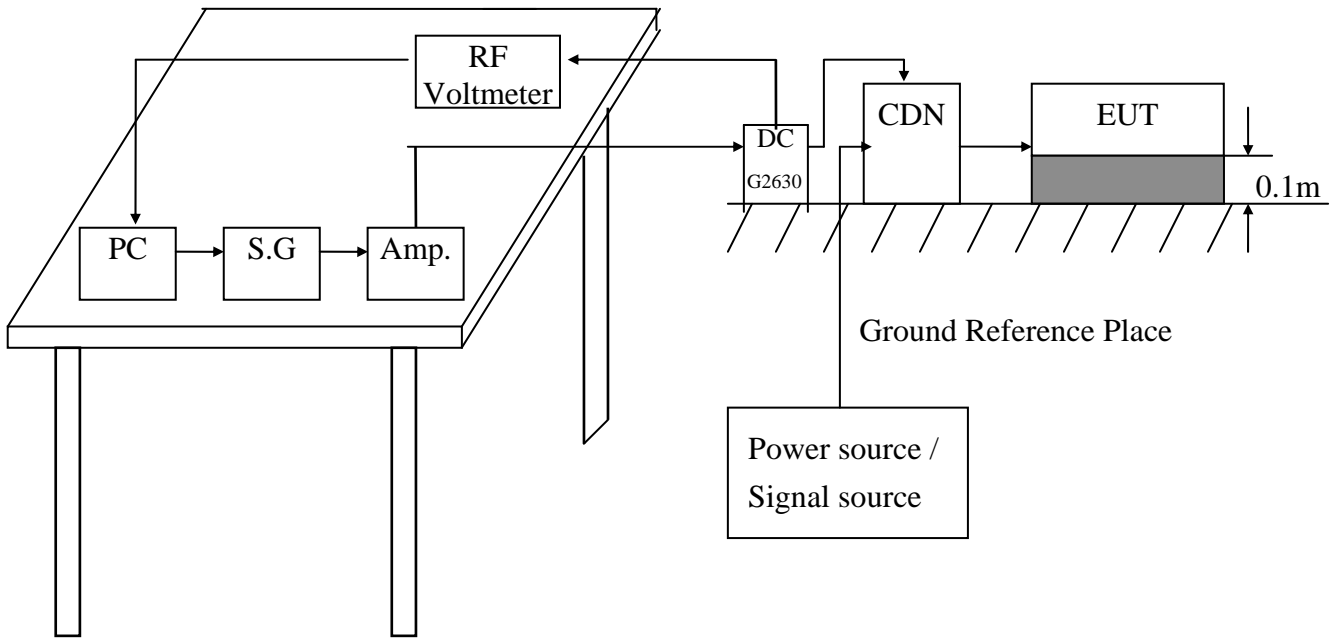

(Details for setup configuration, please refer to appendix A.)

#### 4 TEST LEVELS

- Ports for signal lines and control lines.
- DC input and DC output power ports.
- Input and Output AC Power Ports.
- Functional earth Ports.

Environmental	Test Specification	Units	Performance
Radio-frequency	0.15 - 80	MHz	
Common mode	3	V	A
	80	% AM (1KHz)	

#### 5 CONFIGURATION OF THE EUT

Same as “Conducted Power Line test”, section 4

#### 6 EUT OPERATION CONDITION

Same as “Conducted Power Line test”, section 5

#### 7 CONDITIONS DURING TESTING

7.1 The EUT tested type :

- Single unit
- Multiple unit

7.2 Dwell time : < 1%

7.3 Temperature : 24.3 °C (15°C ~ 35°C)

Humidity : 49 % RH.(10 % ~ 75%)

## 8 PERFORMANCE CRITERIA

- A. The apparatus shall continue to operate as intended during and after the test. No degradation of performance or loss of function is allowed below a performance level specified by the manufacturer, when the apparatus is used as intended.
- B. The apparatus shall continue to operate as intended after the test. No degradation of performance or loss of function is allowed below a performance level specified by the manufacturer, when the apparatus is used as intended. The performance level may be replaced by a permissible loss of performance. During the test, degradation of performance is however allowed.
- C. Temporary loss of function is allowed, provided the function is self-recoverable or can be restored by the operation of the controls.

## 9 TEST RESULT

TEST Specification	Unit	Performance Criteria
0.15 - 80	MHz	A
3	V	
80	% AM (1KHz)	

9.1 Model : HS04

9.2 Test Mode : HDMI in 4 and HDMI out Mode

9.3 Final Result : PASSED

9.4 Remark :

## POWER FREQUENCY MAGNETIC FIELD IMMUNITY TEST

### 1 TEST INSTRUMENTS & FACILITIES

Instruments/ Facilities	Manufacturer	Model # Serial #	Data Of Cal.
LINE INTERFERENCE TESTER	HAEFELY	PLINE 1610 080166-10	FEB/2007
MAGNETIC FIELD TESTER	HAEFELY	MAG 100.1 080206-01	N/A
TRIAXIAL ELF MAGNETIC FIELD METER	F.W.BELL	4080 9645	AUG/2007
CONTROL PC	KB TECH	KB P586/133	--

### 2 TEST STANDARD

According To **IEC 61000-4-8 (2001)**

According To **EN 55024 (1998) + A1 (2001) + A2 (2003)**

### 3 TEST SETUP

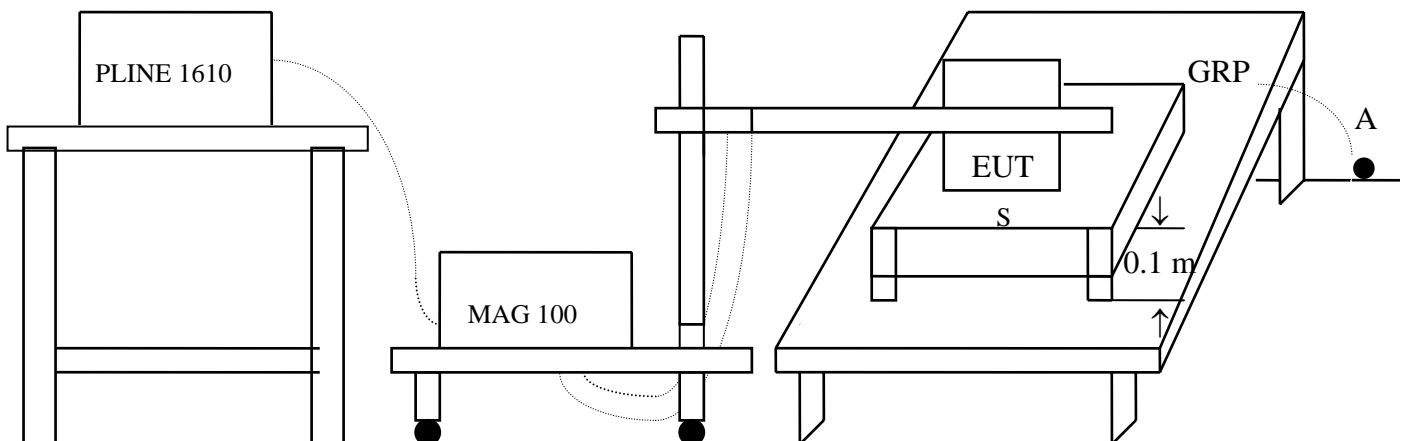

S: Insulating support

A: Safety earth

GRP: Ground plane

(Details for setup configuration, please refer to appendix A.)

#### 4 TEST LEVELS

Environmental Phenomena	Test Specification	Units	Performance Criteria
Power Frequency	50	HZ	
Magnetic Field	1	A/m	B

#### 5 CONFIGURATION OF THE EUT

Same as “Conducted Power Line test”, section 4

#### 6 OPERATION CONDITION OF EUT

Same as “Conducted Power Line test”, section 5

#### 7 CONDITIONS DURING TESTING

7.1 Temperature : 23.8 °C (15°C ~ 35°C)

Humidity : 51 % RH.(25 % ~ 75%)

7.2 The induction coil shall be rotated by 90°

#### 8 PERFORMANCE CRITERIA

- A. The apparatus shall continue to operate as intended during and after the test. No degradation of performance or loss of function is allowed below a performance level specified by the manufacturer, when the apparatus is used as intended.
- B. The apparatus shall continue to operate as intended after the test. No degradation of performance or loss of function is allowed below a performance level specified by the manufacturer, when the apparatus is used as intended. The performance level may be replaced by a permissible loss of performance. During the test, degradation of performance is however allowed.
- C. Temporary loss of function is allowed, provided the function is self-recoverable or can be restored by the operation of the controls.

## 9 TEST RESULTS

Environmental Phenomena	Test Specification	Units	Performance Criteria
Magnetic Field	1	A/m	A

9.1 Model : HS04

9.2 Test Mode : HDMI in 4 and HDMI out Mode

9.3 Final Results : PASSED

9.4 Remark :

## VOLTAGE DIPS, SHORT INTERRUPTIONS IMMUNITY TEST

### 1 TEST INSTRUMENTS & FACILITIES

Instruments/ Facilities	Manufacturer	Model # Serial #	Data Of Cal.
LINE INTERFERENCE -TESTER	EMC PARTNER	TRANSIENT-1000 TRA1000-317	DEC/2006
CONTROL PC	KB TECH	KB P586/133	--

### 2 TEST PROCEDURE

According To **IEC 61000-4-11 (2004)**

According To **EN 55024 (1998) + A1 (2001) + A2 (2003)**

### 3 TEST SETUP

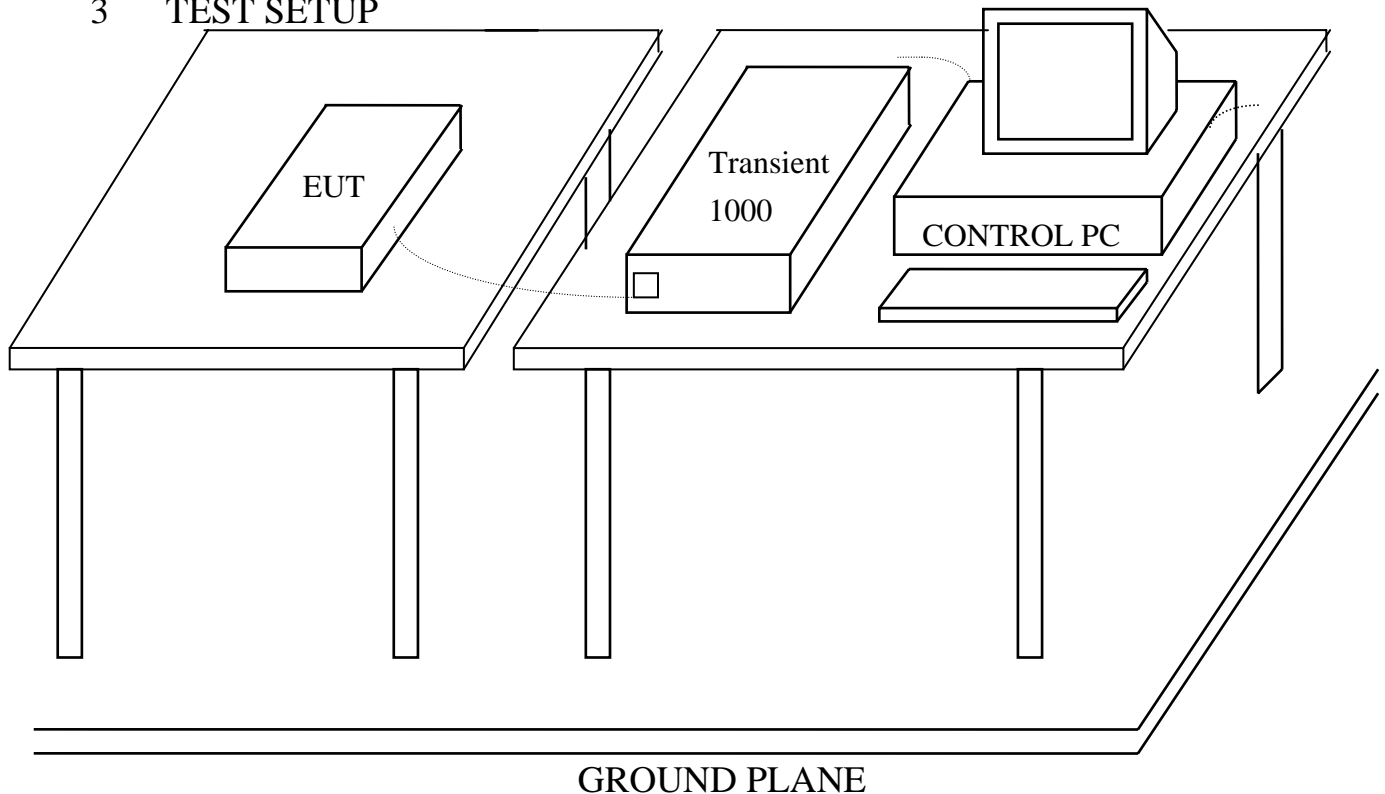

(Details for setup configuration, please refer to appendix A.)

#### 4 TEST LEVELS

Input and Output AC Power Ports.

- Voltage Dips.
- Voltage Interruptions.

Class <sup>a</sup>	Test level and durations for voltage dips				
Class 1	Case-by-case according to the equipment requirements				
Class 2	0 % during 1/2 cycle	0 % during 1 cycle	70 % during 25/30 <sup>c</sup> cycles		
Class 3	0 % during 1/2 cycle	0 % during 1 cycle	40 % during 10/12 <sup>c</sup> cycles	70 % during 25/30 <sup>c</sup> cycles	80 % during 250/300 <sup>c</sup> cycles
a: Classes as per IEC 61000-2-4. b: To be defined by product committee. For equipment connected directly or indirectly to the public network, the levels must not be less severe than Class 2. c: “25/30 cycles” means “25 cycles for 50 Hz test” and “30 cycles for 60 Hz tet”.					

Class <sup>a</sup>	Test level and durations for short interruptions (t <sub>s</sub> ) (50Hz / 60Hz)
Class 1	Case-by-case according to the equipment requirements
Class 2	0 % during 250/300 <sup>c</sup> cycles
Class 3	0 % during 250/300 <sup>c</sup> cycles
Class X <sup>b</sup>	X
a: Classes as per IEC 61000-2-4. b: To be defined by product committee. For equipment connected directly or indirectly to the public network, the levels must not be less severe than Class 2. c: “250/300 cycles” means “250 cycles for 50 Hz test” and “300 cycles for 60 Hz test”.	

✘ **According to the specification of EUT, Class 2 is applied.**

#### 5 CONFIGURATION OF THE EUT

Same as “Conducted Power Line test”, section 4

#### 6 EUT OPERATION CONDITION

Same as “Conducted Power Line test”, section 5

#### 7 CONDITIONS DURING TESTING

7.1 Temperature : 23.6 °C (15°C ~ 35°C)

Humidity : 50 % RH.(25 % ~ 75%)

## 8 PERFORMANCE CRITERIA

- A. The apparatus shall continue to operate as intended during and after the test. No degradation of performance or loss of function is allowed below a performance level specified by the manufacturer, when the apparatus is used as intended.
- B. The apparatus shall continue to operate as intended after the test. No degradation of performance or loss of function is allowed below a performance level specified by the manufacturer, when the apparatus is used as intended. The performance level may be replaced by a permissible loss of performance. During the test, degradation of performance is however allowed.
- C. Temporary loss of function is allowed, provided the function is self-recoverable or can be restored by the operation of the controls.

## 9 TEST RESULT

Environmental Phenomena	Test Specification	Units	Perform Criteria
Voltage Dips	0 1/2	% during Cycle	B
	0 1	% during Cycle	B
	70 25	% during Cycles	C
Voltage Short Interruptions	0 250	% during Cycles	C

9.1 Model : HS04

9.2 Test Mode : HDMI in 4 and HDMI out Mode

9.3 Final Results : PASSED

9.4 Remark :



HomeTek Technology Inc.

## **Appendix A**

# **PHOTOS OF TEST CONFIGURATION**

## PHOTO OF CONDUCTED POWER LINE TEST



**Front View**

## PHOTO OF RADIATED EMISSION TEST



**Front View**



HomeTek Technology Inc.

## **Appendix B**

### **PHOTOS OF EUT**

**PHOTO OF EUT**



**Front View of EUT**

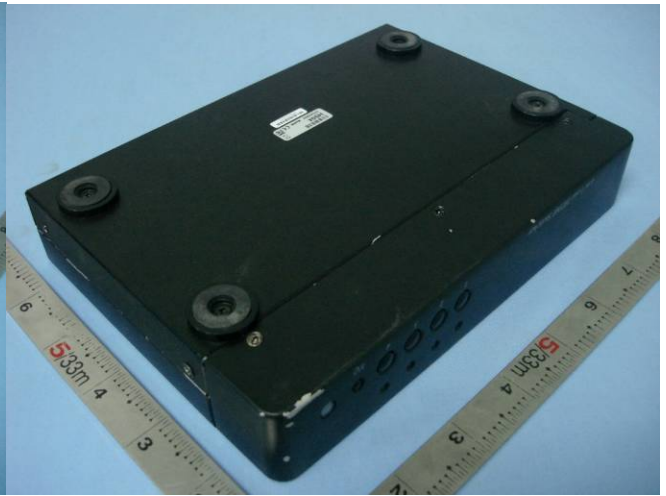

**Rear View of EUT**

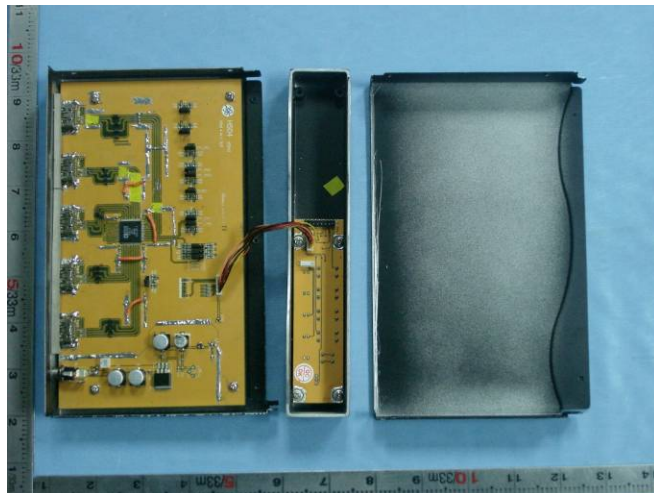

**Inside View of EUT**



**Full View of Adapter**

# Declaration of Conformity

We(Manufacturer/Importer)

---

(company name)

---

(address)

declares under our sole responsibility that the product

Product name : Multimedia AV Switcher

Model No. : HS0XXX

to which this declaration relates is in conformity with the following standard(s) or other normative document(s)

- |   |   |
|---|---|
| <input checked="" type="checkbox"/> EN 55022 Class B (1998) | <input checked="" type="checkbox"/> EN 55024 (1998)       |
| + A1 (2000)   | + A1 (2001)   |
| + A2 (2003)   | + A2 (2003)   |
| <input checked="" type="checkbox"/> EN 61000-3-2 (2006)     | <input checked="" type="checkbox"/> IEC 61000-4-2 (2001)  |
| <input checked="" type="checkbox"/> EN 61000-3-3 (1995)     | <input checked="" type="checkbox"/> IEC 61000-4-3 (2002)  |
| + A1 (2001)   | <input checked="" type="checkbox"/> IEC 61000-4-4 (2004)  |
| + A2 (2005)   | <input checked="" type="checkbox"/> IEC 61000-4-5 (2001)  |
|   | <input checked="" type="checkbox"/> IEC 61000-4-6 (2003)  |
|   | + A1 (2004)   |
|   | <input checked="" type="checkbox"/> IEC 61000-4-8 (2001)  |
|   | <input checked="" type="checkbox"/> IEC 61000-4-11 (2004) |

following the provisions of 2004/108/EC Directive

Place: \_\_\_\_\_ Signature: \_\_\_\_\_

Date : \_\_\_\_\_ Full name: \_\_\_\_\_



Title: \_\_\_\_\_



TÜV Rheinland Taiwan Ltd.

# Certificate of Appointment

for the applicant:

**Hometek Technology Inc.**  
No. 67-9, Shir Men Rd., Tu-Cheng City,  
Taipei Hsien 236, Taiwan, R.O.C.

has been authorized to carry out EMC tests by order and under supervision of TÜV Rheinland. It has successfully demonstrated capability to conduct measurement and to process test data according to:

**European and International EMC Standards as listed in the  
Scope of Authorization on the attachment to this certificate**

An assessment of the facility was conducted by TÜV Rheinland auditors according to the TÜV Rheinland requirements for "Test Site Approval" with reference to

**ISO 17025: 2005**

Certificate No. : 10012161-2007

Valid until : Sept. 7, 2008

TÜV Rheinland Taiwan Ltd.  
Taipei, June 20, 2007

  
Dipl.-Ing. Andreas Klinker  
Certification Body

  
Dipl.-Ing. Bodo Kretzschmar  
Product Safety and Quality



Attachment to  
**Certificate**

of Appointment

SCOPE OF AUTHORIZATION

Hometek Technology Inc.  
No. 67-9, Shir Men Rd., Tu-Cheng City,  
Taipei Hsien 236, Taiwan, R.O.C.

**European Standards**

EN 50081-1	EN 61000-3-3	ENV 50140
EN 50081-2	EN 61000-6-1	ENV 50141
EN 50082-1	EN 61000-6-2	ENV 50204
EN 50130-4	EN 61000-6-3	
EN 50091-2	EN 61000-6-4	
EN 55011	EN 61000-3-11	
EN 55013	EN 61000-4-2	
EN 55014-1	EN 61000-4-3	
EN 55014-2	EN 61000-4-4	
EN 55022	EN 61000-4-5	
EN 55024	EN 61000-4-6	
EN 60601-1-2	EN 61000-4-8	
EN 60801	EN 61000-4-11	
EN 60945	EN 61204-3	
EN 61000-3-2	EN 62040-2	

**International Standards**

CISPR 11	IEC 61000-4-2	IEC 61000-3-2
CISPR 13	IEC 61000-4-3	IEC 61000-3-3
CISPR 14-1	IEC 61000-4-4	IEC 61000-3-11
CISPR 14-2	IEC 61000-4-5	IEC 61000-6-1
CISPR 22	IEC 61000-4-6	IEC 61000-6-2
CISPR 24	IEC 61000-4-8	IEC 61000-6-3
	IEC 61000-4-11	IEC 61000-6-4
IEC 801.2	IEC 61000-4-12	IEC 60945
IEC 801.3		IEC 62040-2
IEC 801.4		

Certificate No. : 10012161-2007

Taipei, June 20, 2007

Dipl.-Ing. Bodo Kretzschmar  
Product Safety and Quality