



## Certificate of Conformity

The products

**EUT : IP CABLING TRANSMISSION**  
**Trade Name : SC&T**  
**Model No. : IP0XX**

which produced by

**SMART CABLING & TRANSMISSION CORP**  
**10F, NO.493, Chung-Cheng Rd., Hsin Tien City, Taipei County, 231,**  
**Taiwan**

Regulation Applied: FCC Rules and Regulations Part 15 Subpart B (2007) /  
CISPR 22 ET Docket No. 95-19 (Doc Procedure)

I HEREBY CERTIFY THAT: The data shown in this report were made in accordance with the procedures given in ANSI C63.4 and the energy emitted by the device was founded to be within the limits applicable. I assume full responsibility for accuracy and completeness of these data.

Signature

Will Yauo

Manager of EMC Testing Department II  
Electronics Testing Center, Taiwan

Report Number :09-05-RBF-074-02

Date of Issue: Jul. 29, 2009

- Note : 1. The result of the testing report relate only to the item tested.**  
**2. The testing report shall not be reproduced expect in full, without the written approval of ETC.**  
**3. The report must not be used by the client to claim product endorsement by NVLAP or any agency of the U.S. Government.**

ELECTRONICS TESTING CENTER, TAIWAN  
NO. 34, LIN 5, DINGFU TSUEN,  
LINKOU SHIANG, TAIPEI COUNTY,  
TAIWAN, 24442, R.O.C.

TEL:(02)26023052  
INT:+886-2-26023052  
FAX:(02)26010910  
INT:+886-2-26010910



NVLAP LAB CODE: 200133-0

Designation Number: TW1044



## FEDERAL COMMUNICATIONS COMMISSION

### *Declaration of Conformity (DoC)*

The following equipment:

Product Name : IP CABLING TRANSMISSION

Trade Name : SC&T

Model Number : IPOXX

is herewith confirmed to comply with the requirements of FCC Part 15 Rules

The operation is subject to the following two conditions:

- (1) This device may not cause harmful interference, and
- (2) This device must accept any interference received, including interference that may cause undesire operation.

The result of electromagnetic emission has been evaluated by ETC EMI Laboratory (NVLAP

LAB CODE:200133-0/ FCC Designation Number: TW1044) and showed in the test

report: 09-05-RBF-074-02

It is understood that each unit marketed is identical to the device as tested, and any changes to the device which could adversely affect the emission characteristics will require retest.

The following importer/manufacturer is responsible for this declaration:

Company Name : \_\_\_\_\_

Company Address : \_\_\_\_\_

Telephone : \_\_\_\_\_ Facsimile : \_\_\_\_\_

Person in responsible for marking this declaration:

\_\_\_\_\_  
Name (Full Name) Position/Title

\_\_\_\_\_  
Legal Signature) Date

自我符合宣告書請依上述文件製作

宣告者須在美國當地，故所填之公司地址、電話、傳真必須是在美國當地。

FCC Doc Label 樣本參考

一般產品或系統標示如下

若產品需與其他已認可之部品裝配使用則標示如下

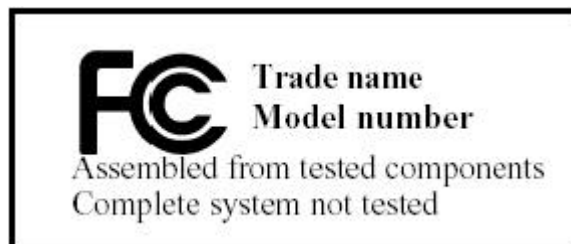
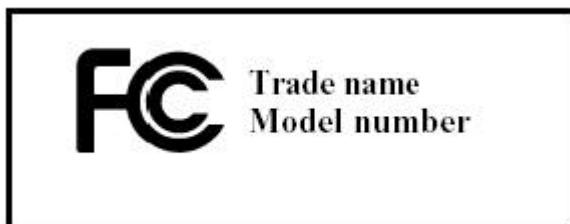

# EMI TEST REPORT

of

E.U.T. : IP CABLING  
TRANSMISSION

MODEL No. : IP0XX

for

APPLICANT : SMART CABLING & TRANSMISSION CORP  
ADDRESS : 10F, NO.493, Chung-Cheng Rd., Hsin Tien City, Taipei  
County, 231, Taiwan

Test Performed by

**ELECTRONICS TESTING CENTER, TAIWAN**  
NO.34, LIN 5, DINGFU TSUEN, LINKOU SHIANG  
TAIPEI COUNTY, TAIWAN, 24442, R.O.C.

TEL : (02)26023052      FAX: (02)26010910

[http:// www.etc.org.tw](http://www.etc.org.tw) ; e-mail: [emc@etc.org.tw](mailto:emc@etc.org.tw)

Report Number : 09-05-RBF-074-02

# TEST REPORT

Applicant : SMART CABLING & TRANSMISSION CORP  
10F, NO.493, Chung-Cheng Rd., Hsin Tien City, Taipei County, 231,  
Taiwan

Manufacturer : SMART CABLING & TRANSMISSION CORP  
10F, NO.493, Chung-Cheng Rd., Hsin Tien City, Taipei County, 231,  
Taiwan

Description of EUT

a) Type of EUT : IP CABLING TRANSMISSION

b) Trade Name : SC&T

c) Model No. : IPOXX

d) Power Adapter : AC Power: 230Vac 50Hz

Regulation Applied : FCC Rules and Regulations Part 15 Subpart B (2007) / CISPR 22  
ET Docket No. 95-19 (Doc Procedure)

I HEREBY CERTIFY THAT: The data shown in this report were made in accordance with the procedures given in ANSI C63.4 and the energy emitted by the device was founded to be within the limits applicable. I assume full responsibility for accuracy and completeness of these data.

- Note: 1. The result of the testing report relate only to the item tested.
2. The testing report shall not be reproduced expect in full, without the written approval of ETC.
3. The report must not be used by the client to claim product endorsement by NVLAP or any agency of the U.S. Government.

Date Test Item Received : May 09, 2009

Date Test Campaign Completed : May 25, 2009

Date of Issue : Jul. 29, 2009

Test Engineer :

*Nudy Huang*

(Nudy Huang, Engineer)

Test Engineer :

*Charles Wang*

( Charles Wang, Supervisor )

Approve & Authorized :

*Will Yauo*

Will Yauo, Manager  
EMC Dept. II of ELECTRONICS  
TESTING CENTER, TAIWAN

<b>Table of Contents</b>	<b>Page</b>
<b>1 GENERAL INFORMATION .....</b>	<b>1</b>
1.1 Product Description and Operation.....	1
1.2 Characteristics of Device .....	1
1.3 Test Methodology .....	2
1.4 Test Facility.....	2
<b>2 PROVISIONS APPLICABLE.....</b>	<b>3</b>
2.1 Definition.....	3
2.2 Requirement for Compliance .....	4
2.3 Labeling Requirement.....	5
2.4 User Information.....	6
<b>3. SYSTEM TEST CONFIGURATION .....</b>	<b>7</b>
3.1 Justification.....	7
3.2 Devices for Tested System.....	7
3.3 Deviation Statement .....	7
<b>4 RADIATED EMISSION MEASUREMENT .....</b>	<b>8</b>
4.1 Applicable Standard .....	8
4.2 Measurement Procedure.....	8
4.3 Measuring Instrument .....	9
4.4 Radiated Emission Data .....	10
.5 Field Strength Calculation .....	11
4.6 Photos of Radiation Measuring Setup .....	12
<b>5 CONDUCTED EMISSION MEASUREMENT .....</b>	<b>13</b>
5.1 Standard Applicable .....	13
5.2 Measurement Procedure.....	13
5.3 Conducted Emission Data .....	14
5.4 Result Data Calculation .....	22
5.5 Conducted Measurement Equipment .....	22
5.6 Photos of Conduction Measuring Setup .....	23

# 1 GENERAL INFORMATION

## 1.1 Product Description and Operation

- a) Type of EUT : IP CABLING TRANSMISSION
- b) Trade Name : SC&T
- c) Model No. : IPOXX
- d) Power Adapter : AC Power: 230Vac 50Hz

## 1.2 Characteristics of Device

ITEM NO.	IPOXX
Link Cable Connector	BNC
Link Cable Distance	1800M (Max)
Link Speed	50 Mbps (Max)
Ethernet Connector	RJ-45
Ethernet Cable Distance	100M (Max)
Ethernet Speed	10M / 100Mbps
Power Supply	DC 5V / 2000mA / Regulated
Power Consumption	750mA (Max)
Dimensions (W x H x D M)	146 x 67 x 27
Weight (g)	220g
Material	Metal Black

### **1.3 Test Methodology**

For EUT, both conducted and radiated emissions were performed according to the procedures in ANSI C63.4 (2003).

### **1.4 Test Facility**

The open area test site and conducted measurement facility used to collect the radiated data is located on the roof top of Building at NO. 34. LIN 5. DINGFU TSUEN, LINKOU SHIANG TAIPEI COUNTY, TAIWAN, 24442, R.O.C.

This site has been fully described in a report submitted to your office, the effective date through Jun. 30, 2009

## 2 PROVISIONS APPLICABLE

### 2.1 Definition

**Unintentional radiator:**

A device that intentionally generates and radio frequency energy for use within the device, or that sends radio frequency signals by conduction to associated equipment via connecting wiring, but which is not intended to emit RF energy by radiation or induction.

**Class B Digital Device :**

A digital device which is marketed for use in a residential environment notwithstanding use in a commercial, business or industrial environment. Example of such devices that are marketed for the general public.

Note : A manufacturer may also qualify a device intended to be marketed in a commercial, business, or industrial environment as a Class B digital device, and in fact is encouraged to do so, provided the device complies with the technical specifications for a Class B Digital Device. In the event that a particular type of device has been found to repeatedly cause harmful interference to radio communications, the Commission may classify such a digital device as a Class B Digital Device, Regardless of its intended use.

## 2.2 Requirement for Compliance

### (1) Conducted Emission Requirement

Except for Class A digital devices, for equipment that is designed to be connected to the public utility (AC) power line, the radio frequency voltage that is conducted back onto the AC power line on any frequency or frequencies within the band 150kHz to 30MHz shall not exceed the limits in the following table, as measured using a 50 $\mu$ H/50 ohms line impedance stabilization network (LISN). Compliance with the provisions of this paragraph shall be based on the measurement of the radio frequency voltage between each power line and ground at the power terminal. The lower limit applies at the band edges.

Frequency MHz	Quasi Peak dB $\mu$ V	Average dB $\mu$ V
0.15 - 0.5	66-56*	56-46*
0.5 - 5.0	56	46
5.0 - 30.0	60	50

\* Decreases with the logarithm of the frequency

### (2) Radiated Emission Requirement

For unintentional device, according to FCC §15.109(a), the field strength of radiated emissions from unintentional radiators at a distance of 3 meters shall not exceed the following values:

Frequency MHz	Distance Meters	Radiated dB $\mu$ V/m	Radiated $\mu$ V/m
30 - 88	3	40.0	100
88 - 216	3	43.5	150
216 - 960	3	46.0	200
Above 960	3	54.0	500

For unintentional device, according to CISPR Radiated Emission Limits class B is as following:

Frequency MHz	Distance Meters	Radiated dB $\mu$ V/m
30 to 230	10	30
230 to 1000	10	37

### 2.3 Labeling Requirement

Products subject to authorization under a Declaration of Conformity shall be labeled as follows:

- (1) The label shall be located in a conspicuous location on the device and shall contain the unique identification described in Section 2.1074 of this chapter and the following logo:
  - (i) IF the product is authorized based on testing of the product or system:

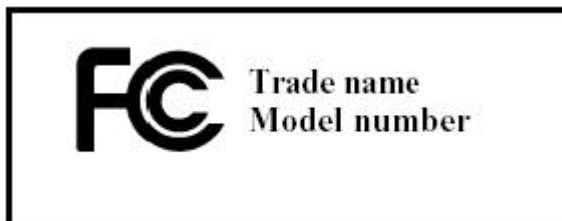

- (ii) If the product is authorized based on assembly using separately authorized components, in accordance with Section 15.101(c)(2) or (c)(3), and the resulting product is not separately tested:

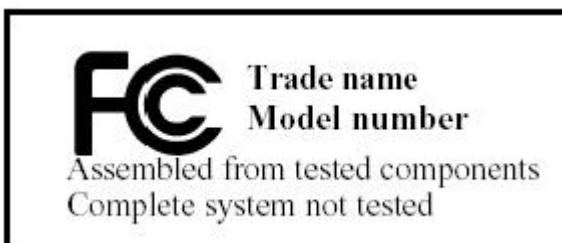

- (2) Label text and information should be in a size of type large enough to be readily legible, consistent with the dimensions of the equipment and the label. However, the type size for the text is not required to be larger than eight point.
- (3) When the device is so small or for such used that it is not practicable to place the statement specified under paragraph (b)(1) of this section on it, such as for a CPU board or a plug-in circuit board peripheral device, the text associated with the logo may be placed in a prominent location in the instruction manual or pamphlet supplied to the user. However, the unique identification (trade name and model number) and the logo must be displayed on the device.
- (4) The label shall not be a stick-on, paper label. The label on these products shall be permanently affixed to the product and shall be readily visible to the purchaser at the time of purchase, as described in Section 2.925(d) of this chapter. “Permanently affixed” means that the label is etched, engraved, stamped, silkscreened, indelibly printed, or otherwise permanently marked on a permanently attached part of the equipment or an a nameplate of metal, plastic, or other material fastened to the equipment by welding, riveting, or a permanent adhesive. The label must be designed to the last the expected lifetime of the equipment in the environment in which the equipment may be operated and must not be readily detachable.

## 2.4 User Information

The users manual or instruction manual for an intentional or unintentional radiator shall caution the user that changes or modifications not expressly approved by the party responsible for compliance could void the user's authority to operate the equipment.

For a Class B digital device or peripheral, the instructions furnished the user shall include the following or similar statement, placed in a prominent location in the text of the manual.

The Federal Communications Commission Radio Frequency Interference Statement includes the following paragraph.

This equipment has been tested and found to comply with the limits for a Class B Digital Device, pursuant to Part 15 of the FCC Rules. These limits are designed to provide reasonable protection against harmful interference in a residential installation.

This equipment generates, uses and can radiate radio frequency energy and, if not installed and used in accordance with the instruction may cause harmful interference to radio communication. However, there is no guarantee that interference will not occur in a particular installation.

If this equipment does cause harmful interference to radio or television reception, which can be determined by turning the equipment off and on, the user is encouraged to try to correct the interference by one or more of the following measures:

- Reorient or relocate the receiving antenna.
- Increase the separation between the equipment and receiver.
- Connect the equipment into an outlet on a circuit different from that to which the receiver is connected.
- Consult the dealer or an experienced radio / TV technician for help.

### 3. SYSTEM TEST CONFIGURATION

#### 3.1 Justification

The system was configured for testing in a typical fashion, as a customer would normally use it.

For radiated emission measuring, the EUT was rotated to obtain the maximum level of radiated emissions. The antenna was varied in height from 1 to 4 meters above ground to obtain the maximum signal strength. Measurement was performed under the condition that a computer program was exercised to simulate data communication of EUT. Three highest emissions were verified with varying placement of the connected cable to maximize the emission from EUT.

#### 3.2 Devices for Tested System

Device	Model No.	Manufacturer	Description
IP CABLING TRANSMISSION*	IPOXX	SMART CABLING & TRANSMISSION CORP	1.8m Unshielded AC Adapter Power

Remark “\*” means equipment under test.

#### 3.3 Deviation Statement

(If any deviation from additions to or exclusions from test method must be stated)

N/A

## 4 RADIATED EMISSION MEASUREMENT

### 4.1 Applicable Standard

For unintentional radiator digital devices, the radiated emission shall comply with § 15.109(a). And according to § 15.109 (g), as an alternative to the radiated emission limits is CISPR 22.

### 4.2 Measurement Procedure

1. Setup the configuration per figure 1.
2. For emission frequencies measured below 1 GHz, a pre-scan is performed in a shielded chamber to determine the accurate frequencies of higher emissions will be checked on a open test site.
3. The search antenna is to be raised and lowered over a range from 1 to 4 meters in horizontally polarized orientation. Position the highness when the highest value is indicated on spectrum analyzer, then change the orientation of EUT on test table over a range from 0° to 360° with a speed as slow as possible, and keep the azimuth that highest emission is indicated on the spectrum analyzer. Vary the antenna position again and record the highest value as a final reading. A RF test receiver is also used to confirm emissions measured.
4. Repeat step 3 until all frequencies need to be measured were complete.
5. Repeat step 4 with search antenna in vertical polarized orientations.
6. Check the three frequencies of highest emission with varying the placement of cables associated with EUT to obtain the worse case and record the result.

Figure 1 : Frequencies measured below 1 GHz configuration

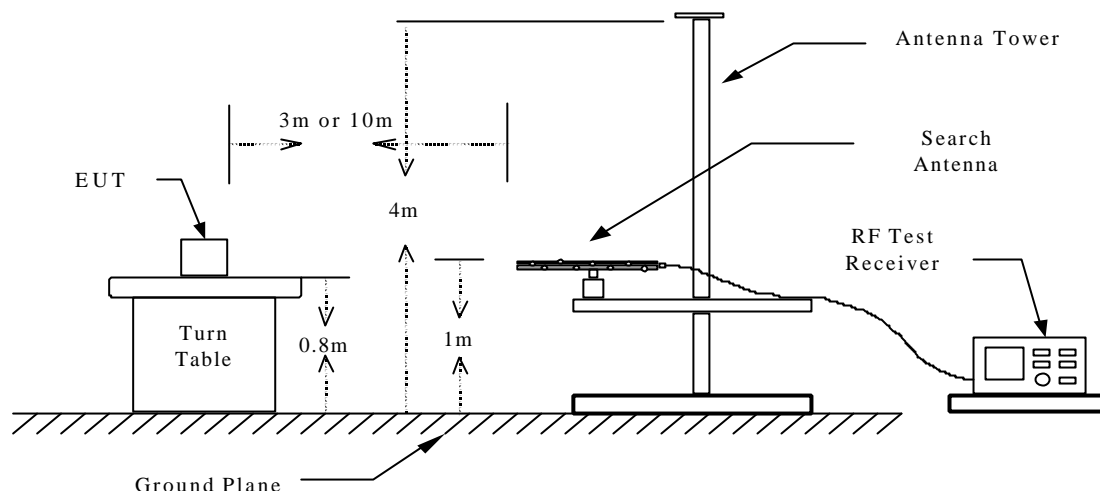

### 4.3 Measuring Instrument

The following instrument are used for radiated emissions measurement :

Equipment	Manufacturer	Model No.	Calibration Date	Next Cal. Date
Test Receiver	Rohde & Schwarz	ESCI	2009/02/04	2010/02/03
Amplifier	HP	8447D	2008/09/05	2009/09/04
Spectrum	Advantest	R3162	2009/02/03	2010/02/02
Bi-Log Antenna	Schaffner	CBL 6111	2009/05/06	2010/05/05
Log-periodic Antenna	EMCO	3115	2009/05/12	2010/05/11

Note: The standards used to perform this calibration are traceable to NML/ROC, NIST/USA and NPL/UK.

Measuring instrument setup in measured frequency band when specified detector function is used :

Frequency Band (MHz)	Instrument	Function	Resolution bandwidth	Video Bandwidth
30 to 1000	RF Test Receiver	Quasi-Peak	120 kHz	N/A
	Spectrum Analyzer	Peak	100 kHz	100 kHz
Above 1000	Spectrum Analyzer	Peak	1 MHz	1 MHz
	Spectrum Analyzer	Average	1 MHz	10Hz

## 4.4 Radiated Emission Data

A.

Operation Mode : Operation

Ant-Pol: Horizontal

Power Supply : 120Vac, 60Hz

Test Date : May 25, 2009

Temperature : 25 °C

Humidity : 67 %

Emission Frequency (MHz)	Meter Reading (dB $\mu$ V)	Corr'd Factor (dB)	Results (dB $\mu$ V/m)	Limit @ 3m (dB $\mu$ V/m)	Margin (dB)	AH (m)	DRT degree
39.300	41.3	-11.7	29.6	40.0	-10.4	1.5	180
203.100	34.7	-6.9	27.8	43.5	-15.7	1.0	180
572.500	43.7	-5.3	38.4	46.0	-7.6	1.5	90
597.800	39.8	-4.6	35.2	46.0	-10.8	1.5	180
743.600	33.9	-0.4	33.5	46.0	-12.5	2.0	90
804.200	31.5	0.8	32.3	46.0	-13.7	1.0	90

Operation Mode : Operation

Ant-Pol: Vertical

Emission Frequency (MHz)	Meter Reading (dB $\mu$ V)	Corr'd Factor (dB)	Results (dB $\mu$ V/m)	Limit @ 3m (dB $\mu$ V/m)	Margin (dB)	AH (m)	DRT degree
39.300	44.2	-11.7	32.5	40.0	-7.5	1.5	180
203.100	40.8	-6.9	33.9	43.5	-9.6	1.0	180
572.500	39.9	-5.3	34.6	46.0	-11.4	1.5	90
597.800	43.5	-4.6	38.9	46.0	-7.1	1.5	180
743.600	38.2	-0.4	37.8	46.0	-8.2	2.0	90
804.200	34.4	0.8	35.2	46.0	-10.8	1.0	90

Note :

1. Remark "---" means that the emissions from EUT are too weak to be measured.
2. AH means antenna height, DRT means degrees of rotation of turntable.
3. The expanded uncertainty of the radiated emission tests is 3.53 Db.

## .5 Field Strength Calculation

The field strength is calculated by adding the Antenna Factor, High Pass Filter Loss and Cable Loss, and subtracting the Amplifier Gain (if any) from the measured reading. The basic equation calculation is as follows:

$$\mathbf{Result = Reading + Corrected Factor}$$

where

Corrected Factor = Antenna FACTOR + Cable Loss + High Pass Filter Loss - Amplifier Gain

### 4.6 Photos of Radiation Measuring Setup



## 5 CONDUCTED EMISSION MEASUREMENT

### 5.1 Standard Applicable

For unintentional and intentional device, Line Conducted Emission Limits are in accordance to §5.107(a) and §5.207(a) respectively .

### 5.2 Measurement Procedure

1. Setup the configuration per figure 2.
2. A preliminary scan with a spectrum monitor is performed to identify the frequency of emission that has the highest amplitude relative to the limit by operating the EUT in selected modes of operation, typical cable positions, and with a typical system configuration.
3. Record the 6 or 8 highest emissions relative to the limit.
4. Measure each frequency obtained from step 3 by a test receiver set on quasi peak detector function, and then records the accuracy frequency and emission level. If all emissions measured in the specified band are attenuated more than 20 dB from the limit, this step would be ignored, and the peak detector function would be used.
5. Confirm the highest three emissions with variation of the EUT cable configuration and record the final data.
6. Repeat all above procedures on measuring each operation mode of EUT.

Figure 2 : Conducted emissions measurement configuration

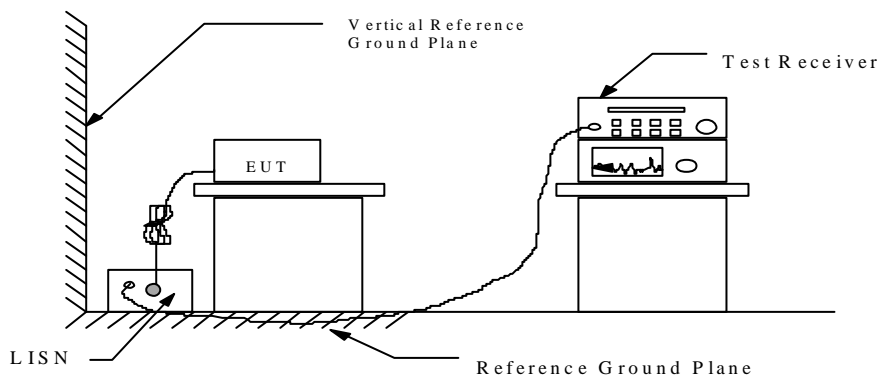

### 5.3 Conducted Emission Data

#### A. Model: Transmitter

Operation Mode : Operation Neutral

Power Supply : 120Vac, 60Hz

Test Date : May 25, 2009 Temperature : 25 °C Humidity : 67 %

Frequency (MHz)	Meter Reading (dBμV)		Factor (dB)	Result (dBμV)		Limit (dBμV)		Margin (dBμV)	
	Q.P	AVG		Q.P	AVG	Q.P	AVG	Q.P	AVG
	0.154	39.8		----	0.2	40.0	----	65.8	55.8
0.173	41.2	----	0.2	41.4	----	64.8	54.8	-23.4	----
0.192	42.4	----	0.2	42.6	----	63.9	53.9	-21.3	----
0.240	39.6	----	0.2	39.8	----	62.1	52.1	-22.3	----
0.372	36.5	----	0.3	36.8	----	58.5	48.5	-21.7	----
0.407	40.5	----	0.3	40.8	----	57.7	47.7	-16.9	----

Note : The expanded uncertainty of the conducted emission tests is 2.45 dB.

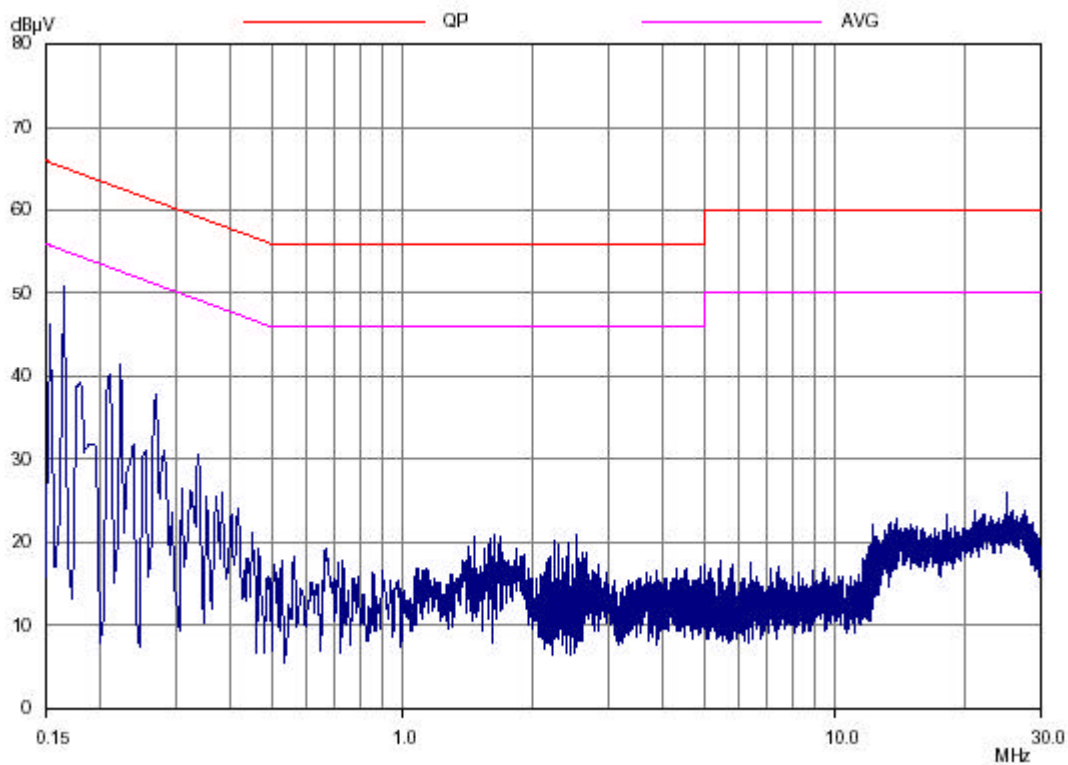

**A. Model: Transmitter**

Operation Mode : Operation

Line

Power Supply : 120Vac, 60Hz

Test Date : May 25, 2009    Temperature : 25 °C    Humidity : 67 %

Frequency (MHz)	Meter Reading (dBμV)		Factor (dB)	Result (dBμV)		Limit (dBμV)		Margin (dBμV)	
	Q.P	AVG		Q.P	AVG	Q.P	AVG	Q.P	AVG
	0.159	40.1		----	0.2	40.3	----	65.5	55.5
0.165	42.3	----	0.2	42.5	----	65.2	55.2	-22.7	----
0.307	39.4	----	0.3	39.7	----	60.1	50.1	-20.4	----
0.347	40.5	----	0.3	40.8	----	59.0	49.0	-18.3	----
0.408	37.5	----	0.3	37.8	----	57.7	47.7	-19.9	----
0.572	35.4	----	0.3	35.7	----	56.0	46.0	-20.3	----

Note : The expanded uncertainty of the conducted emission tests is 2.45 dB.

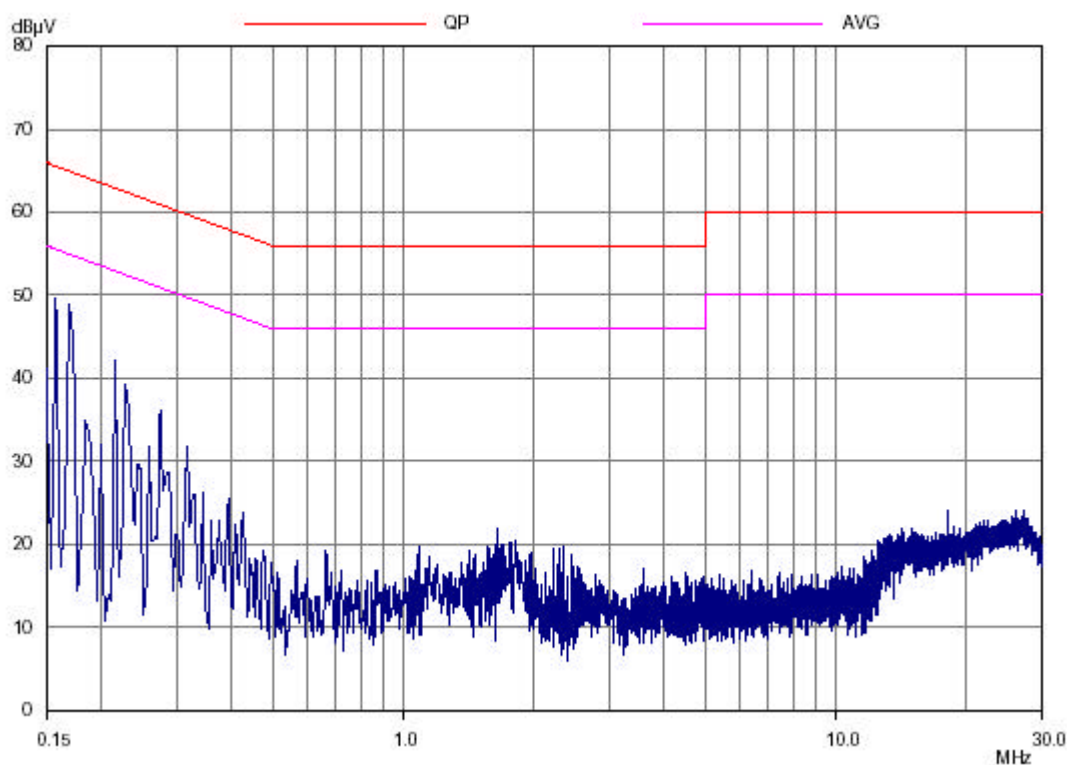

**B. Model: Receiver**

Operation Mode : Operation Neutral

Power Supply : 120Vac, 60Hz

Test Date : May 25, 2009 Temperature : 25 °C Humidity : 67 %

Frequency (MHz)	Meter Reading (dBμV)		Factor (dB)	Result (dBμV)		Limit (dBμV)		Margin (dBμV)	
	Q.P	AVG		Q.P	AVG	Q.P	AVG	Q.P	AVG
	0.157	39.6		----	0.2	39.8	----	65.6	55.6
0.170	40.5	----	0.2	40.7	----	65.0	55.0	-24.3	----
0.192	42.1	----	0.2	42.3	----	63.9	53.9	-21.6	----
0.237	38.5	----	0.2	38.7	----	62.2	52.2	-23.5	----
0.327	36.8	----	0.3	37.1	----	59.5	49.5	-22.5	----
0.396	41.2	----	0.3	41.5	----	57.9	47.9	-16.4	----

Note : The expanded uncertainty of the conducted emission tests is 2.45 dB.

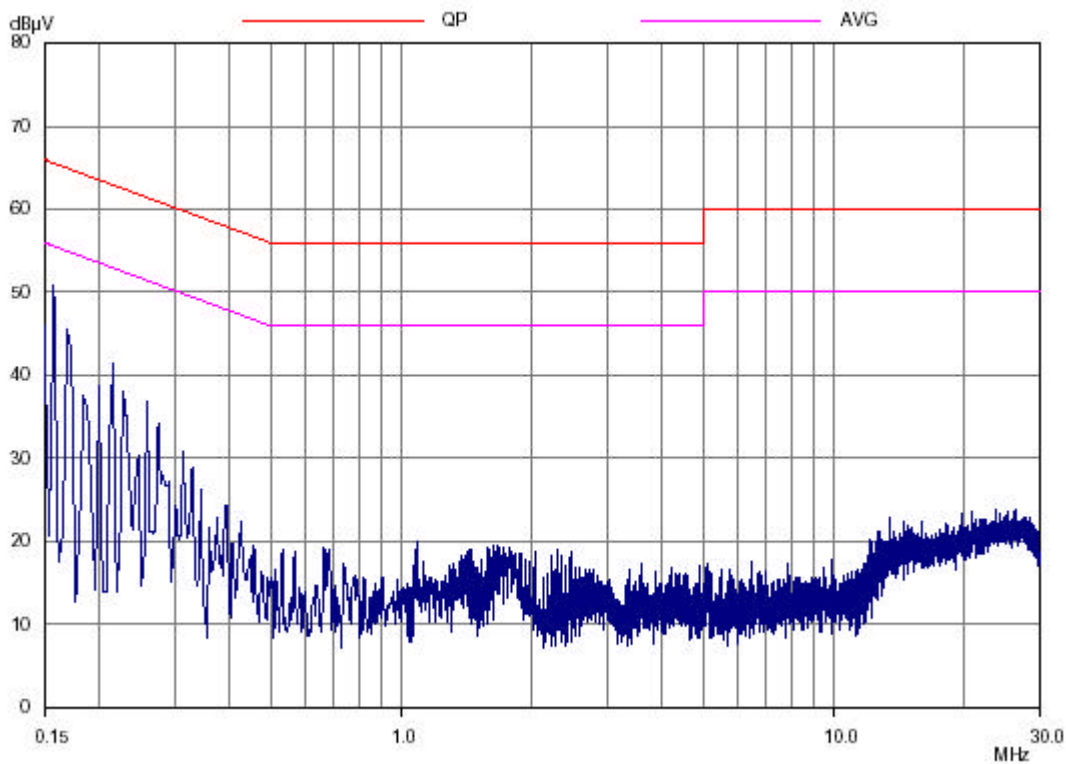

**B. Model: Receiver**

Operation Mode : Operation

Line

Power Supply : 120Vac, 60Hz

Test Date : May 25, 2009 Temperature : 25 °C Humidity : 67 %

Frequency (MHz)	Meter Reading (dBμV)		Factor (dB)	Result (dBμV)		Limit (dBμV)		Margin (dBμV)	
	Q.P	AVG		Q.P	AVG	Q.P	AVG	Q.P	AVG
	0.156	40.5		----	0.2	40.7	----	65.7	55.7
0.177	42.6	----	0.2	42.8	----	64.6	54.6	-21.8	----
0.273	38.5	----	0.2	38.7	----	61.0	51.0	-22.3	----
0.374	40.5	----	0.3	40.8	----	58.4	48.4	-17.6	----
0.404	38.5	----	0.3	38.8	----	57.8	47.8	-19.0	----
0.572	39.6	----	0.3	39.9	----	56.0	46.0	-16.1	----

Note : The expanded uncertainty of the conducted emission tests is 2.45 dB.

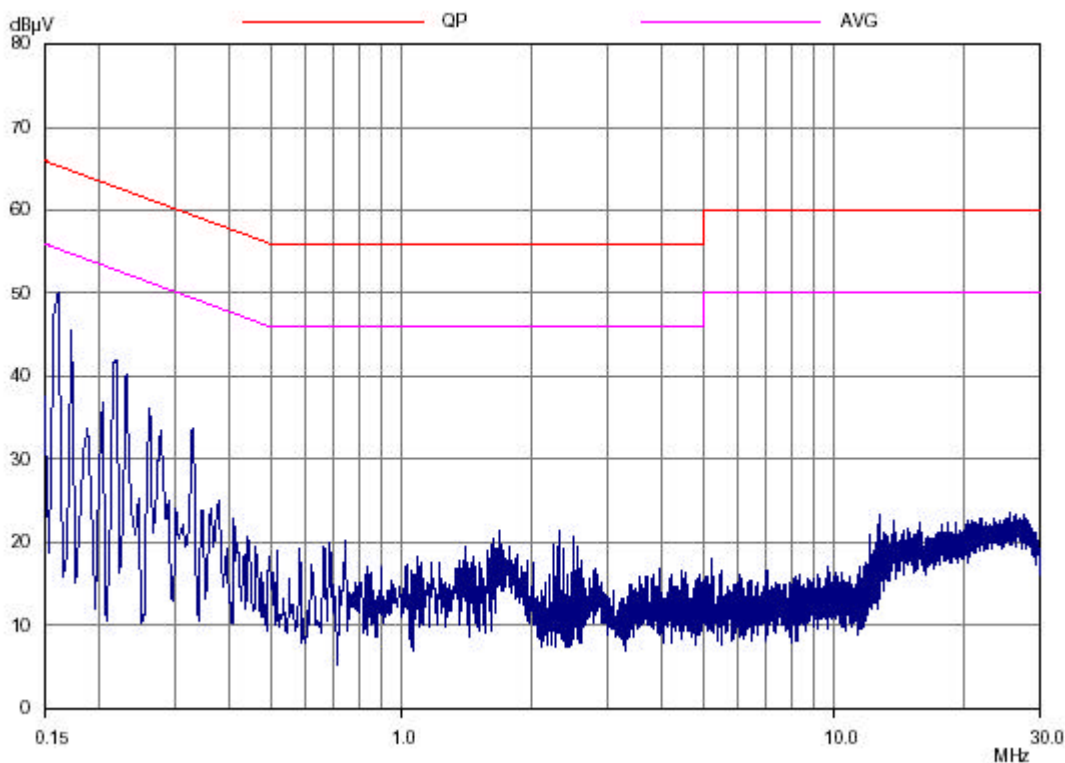

**C. Model: Transmitter**

Operation Mode : Operation Neutral

Power Supply : 120Vac, 60Hz

Test Date : May 25, 2009 Temperature : 25 °C Humidity : 67 %

Frequency (MHz)	Meter Reading (dBμV)		Factor (dB)	Result (dBμV)		Limit (dBμV)		Margin (dBμV)	
	Q.P	AVG		Q.P	AVG	Q.P	AVG	Q.P	AVG
	0.157	43.6		----	0.2	43.8	----	65.6	55.6
0.167	40.5	----	0.2	40.7	----	65.1	55.1	-24.4	----
0.187	39.6	----	0.2	39.8	----	64.2	54.2	-24.4	----
0.294	38.1	----	0.2	38.3	----	60.4	50.4	-22.1	----
0.327	37.6	----	0.3	37.9	----	59.5	49.5	-21.7	----
0.373	40.4	----	0.3	40.7	----	58.4	48.4	-17.7	----

Note : The expanded uncertainty of the conducted emission tests is 2.45 dB.

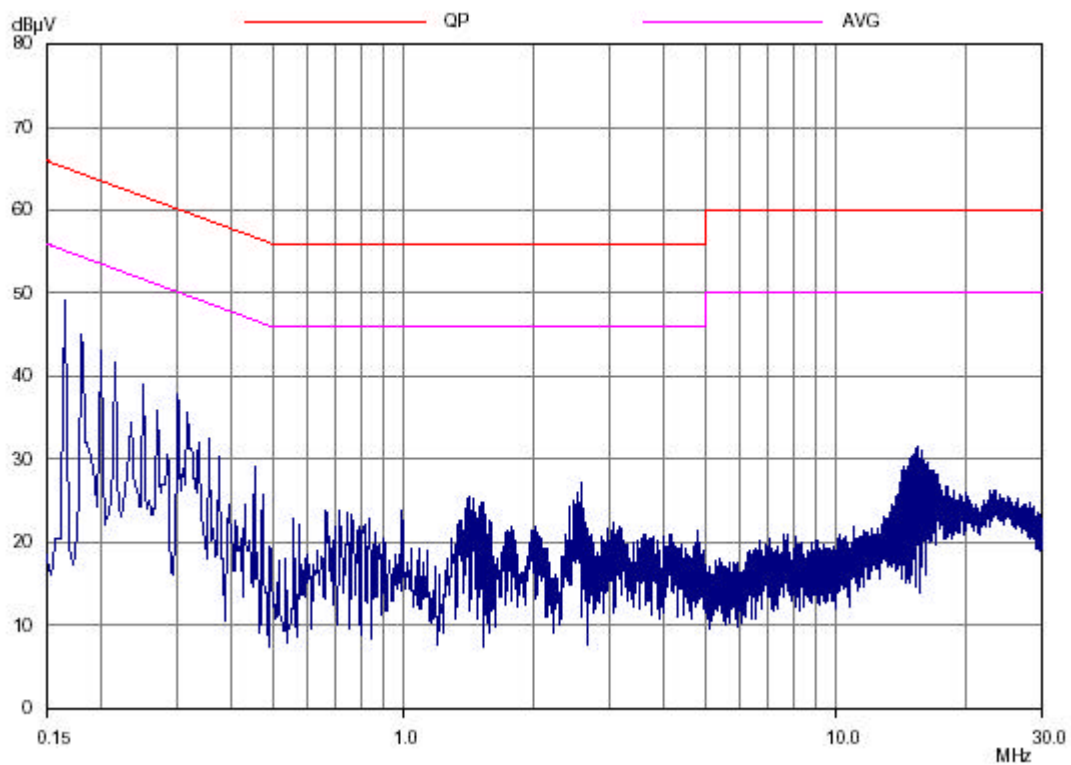

**C. Model: Transmitter**

Operation Mode : Operation

Line

Power Supply : 120Vac, 60Hz

Test Date : May 25, 2009 Temperature : 25 °C Humidity : 67 %

Frequency (MHz)	Meter Reading (dBμV)		Factor (dB)	Result (dBμV)		Limit (dBμV)		Margin (dBμV)	
	Q.P	AVG		Q.P	AVG	Q.P	AVG	Q.P	AVG
	0.153	40.2		----	0.2	40.4	----	65.8	55.8
0.163	41.8	----	0.2	42.0	----	65.3	55.3	-23.3	----
0.207	38.4	----	0.2	38.6	----	63.3	53.3	-24.7	----
0.248	39.1	----	0.2	39.3	----	61.8	51.8	-22.5	----
0.327	36.5	----	0.3	36.8	----	59.5	49.5	-22.8	----
0.405	40.2	----	0.3	40.5	----	57.8	47.8	-17.3	----

Note : The expanded uncertainty of the conducted emission tests is 2.45 dB.

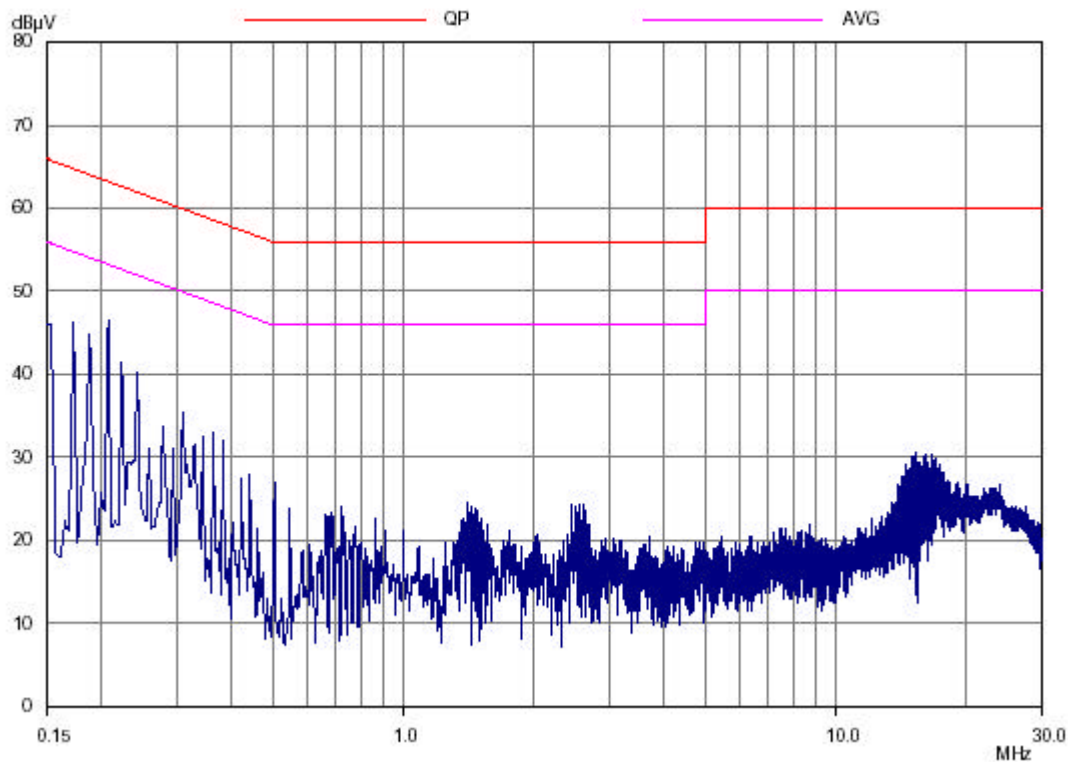

**D. Model: Receiver**

Operation Mode : Operation Neutral

Power Supply : 120Vac, 60Hz

Test Date : May 25, 2009 Temperature : 25 °C Humidity : 67 %

Frequency (MHz)	Meter Reading (dBμV)		Factor (dB)	Result (dBμV)		Limit (dBμV)		Margin (dBμV)	
	Q.P	AVG		Q.P	AVG	Q.P	AVG	Q.P	AVG
	0.150	45.6		----	0.2	45.8	----	66.0	56.0
0.173	43.8	----	0.2	44.0	----	64.8	54.8	-20.8	----
0.189	40.7	----	0.2	40.9	----	64.1	54.1	-23.2	----
0.208	39.1	----	0.2	39.3	----	63.3	53.3	-24.0	----
0.224	36.7	----	0.2	36.9	----	62.7	52.7	-25.8	----
0.294	30.2	----	0.2	30.4	----	60.4	50.4	-30.0	----

Note : The expanded uncertainty of the conducted emission tests is 2.45 dB.

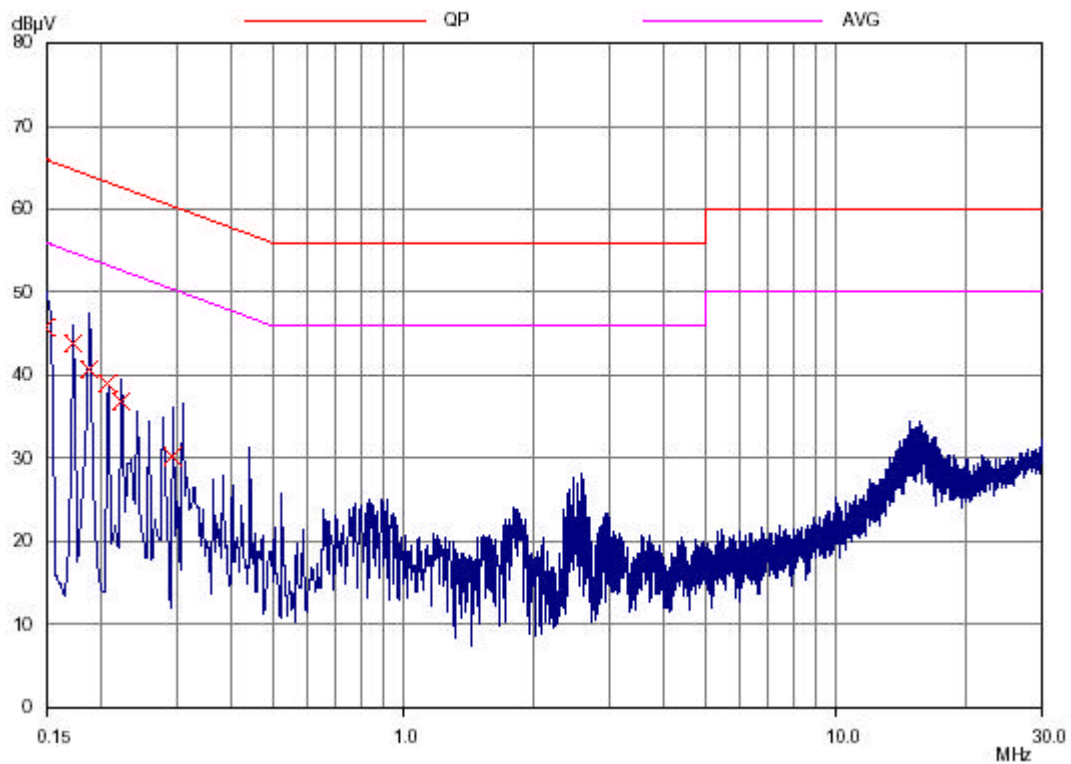

**D. Model: Receiver**

Operation Mode : Operation

Line

Power Supply : 120Vac, 60Hz

Test Date : May 25, 2009    Temperature : 25 °C    Humidity : 67 %

Frequency (MHz)	Meter Reading (dBμV)		Factor (dB)	Result (dBμV)		Limit (dBμV)		Margin (dBμV)	
	Q.P	AVG		Q.P	AVG	Q.P	AVG	Q.P	AVG
	0.157	43.2		----	0.2	43.4	----	65.6	55.6
0.177	42.4	----	0.2	42.6	----	64.6	54.6	-22.0	----
0.192	39.5	----	0.2	39.7	----	63.9	53.9	-24.2	----
0.212	38.8	----	0.2	39.0	----	63.1	53.1	-24.1	----
0.228	36.2	----	0.2	36.4	----	62.5	52.5	-26.1	----
0.247	35.2	----	0.2	35.4	----	61.9	51.9	-26.4	----

Note : The expanded uncertainty of the conducted emission tests is 2.45 dB.

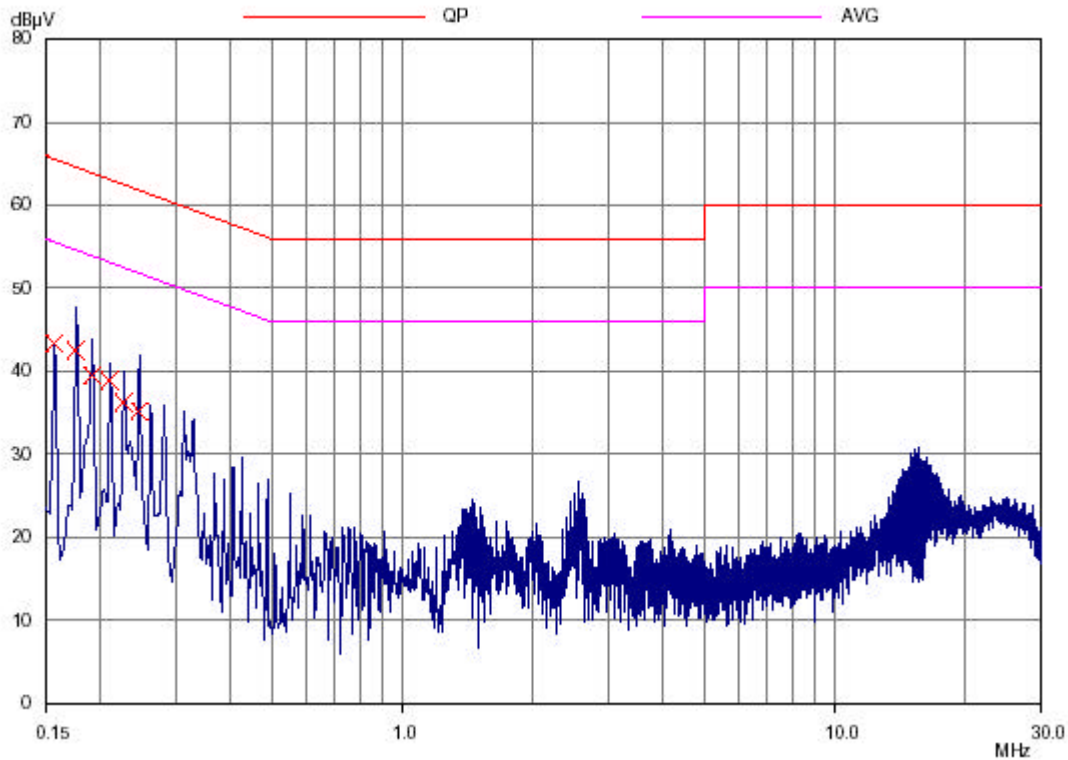

## 5.4 Result Data Calculation

The result data is calculated by adding the LISN Factor to the measured reading. The basic equation with a sample calculation is as follows:

$$\mathbf{RESULT = READING + LISN FACTOR}$$

Assume a receiver reading of 22.5 dB  $\mu$  V is obtained, and LISN Factor is 0.1 dB, then the total of disturbance voltage is 22.6 dB  $\mu$  V.

$$RESULT = 22.5 + 0.1 = 22.6 \text{ dB } \mu \text{ V}$$

$$\begin{aligned} \text{Level in } \mu \text{ V} &= \text{Common Antilogarithm}[(22.6 \text{ dB } \mu \text{ V})/20] \\ &= 13.48 \mu \text{ V} \end{aligned}$$

## 5.5 Conducted Measurement Equipment

The following test equipment are used during the conducted test .

Equipment	Manufacturer	Model No.	Calibration Date	Next Cal. Date
EMI Test Receiver	Rohde & Schwarz	ESCI	2009/02/04	2010/02/03
LISN	EMCO	3625/2	2009/02/06	2010/02/05
LISN	Rohde & Schwarz	ESH2-Z5	2009/06/27	2010/06/26

### 5.6 Photos of Conduction Measuring Setup

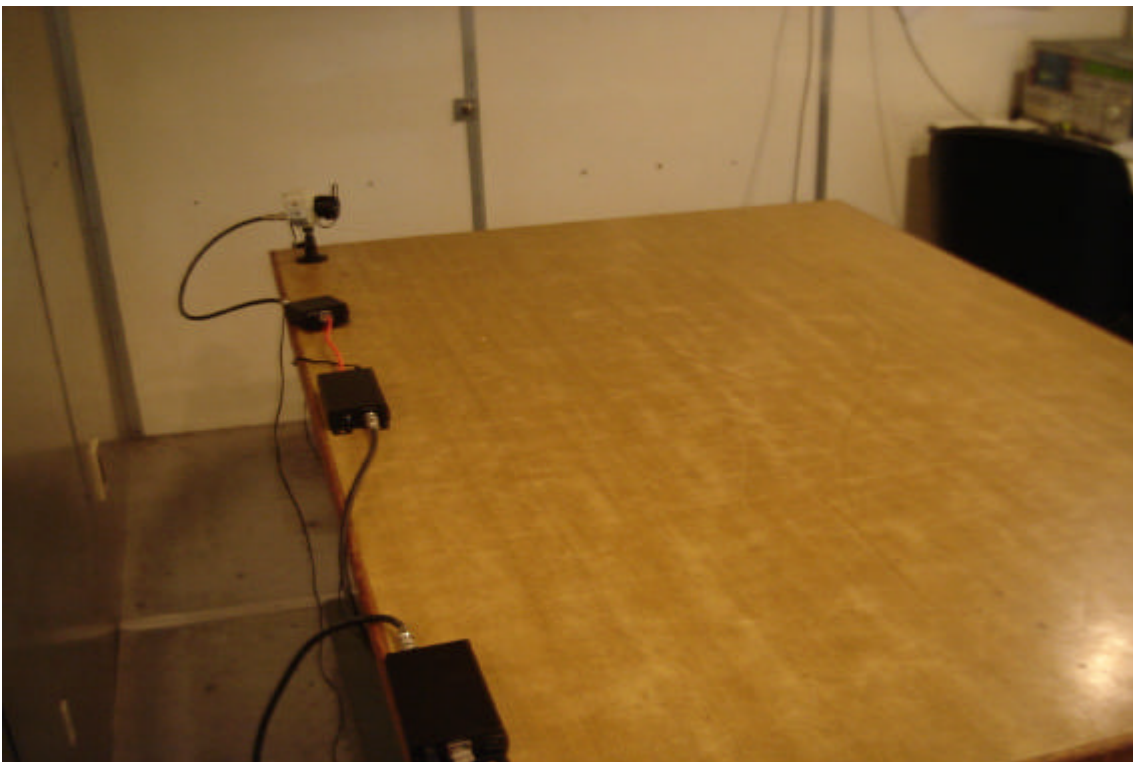
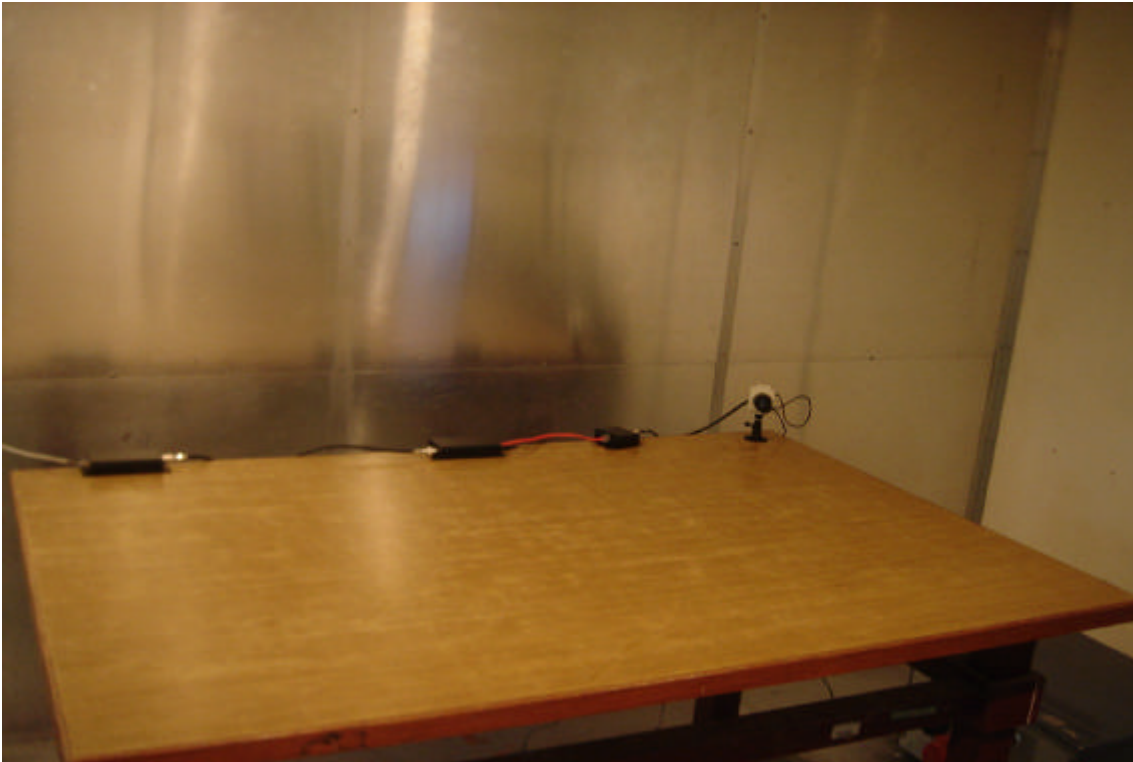

## CONSTRUCTED PHOTOS of EUT

### 1. Top View of EUT



### 2. Bottom View of EUT



## CONSTRUCTED PHOTOS of EUT

### 3. Front View of EUT



### 4. Rear View of EUT



## CONSTRUCTED PHOTOS of EUT

5. Side View of EUT

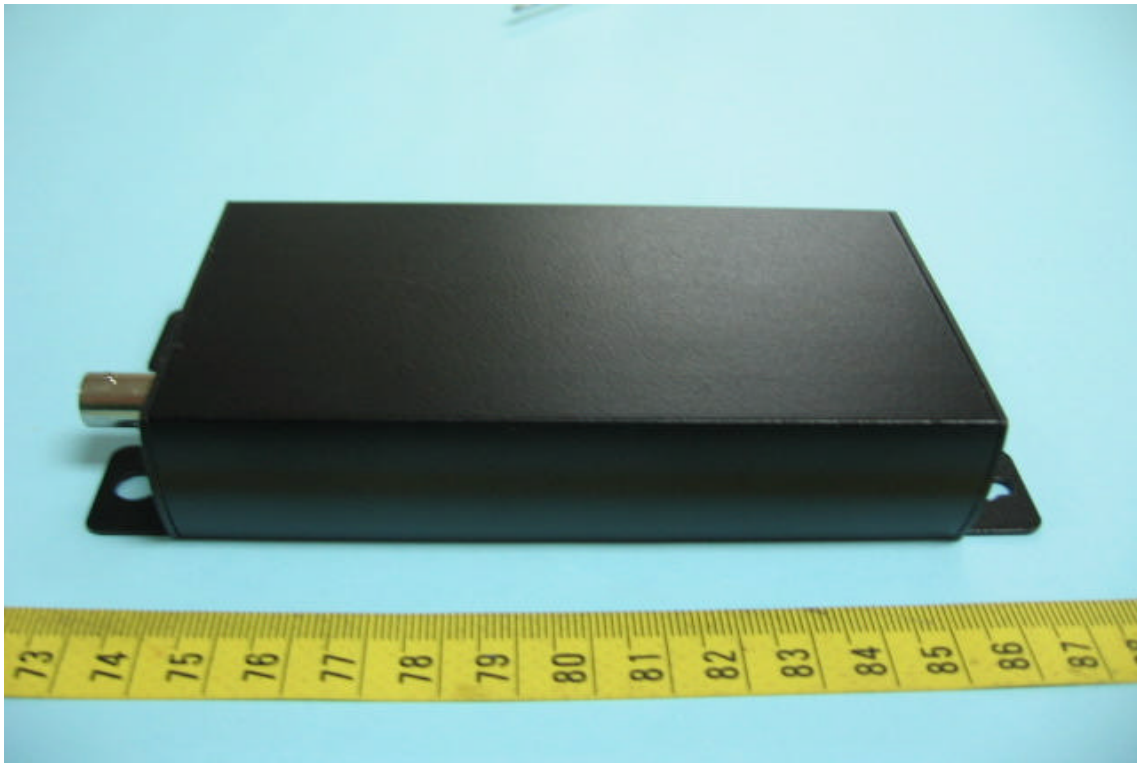

6. Side View of EUT

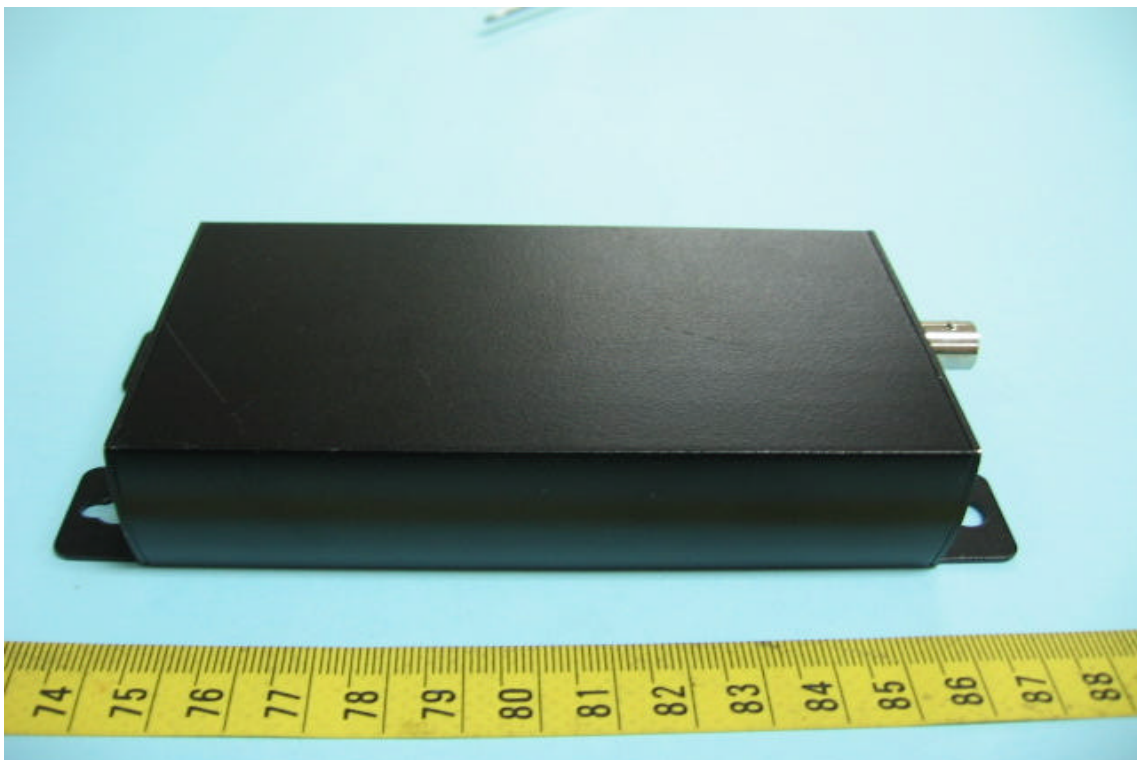

## CONSTRUCTED PHOTOS of EUT

### 7. Component View of PCB

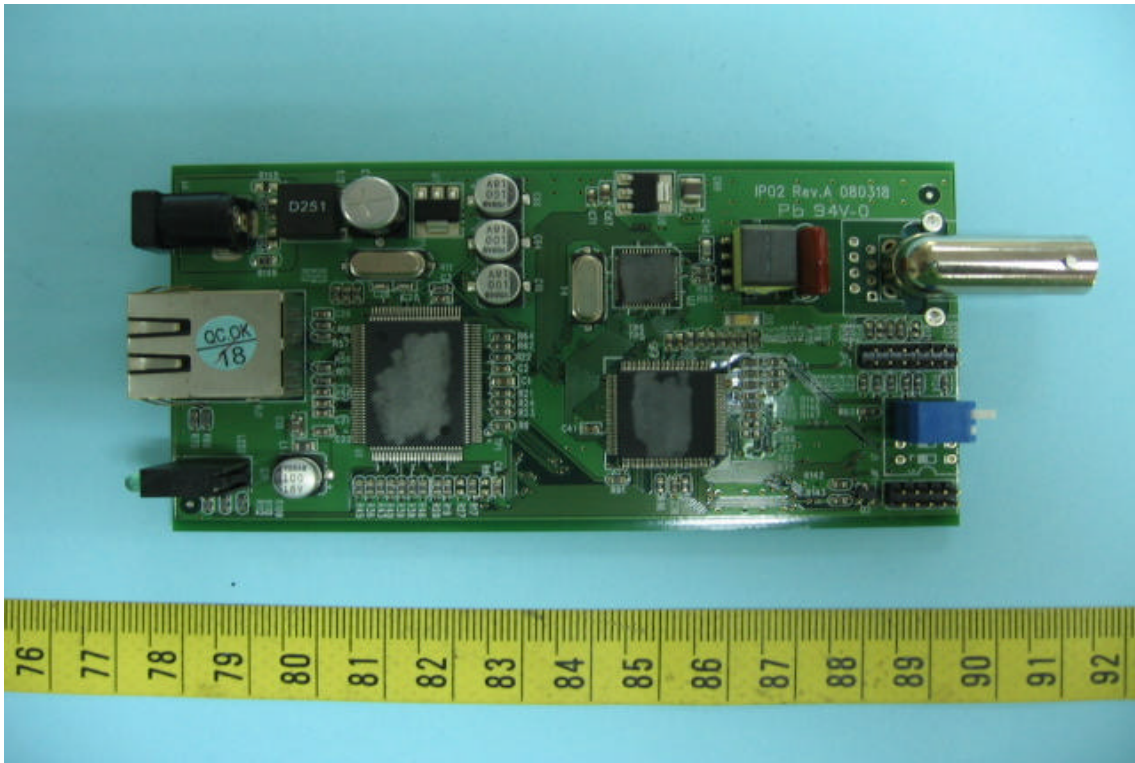

### 8. Solder View of PCB

