

HomeTek Technology Inc.

ADDRESS: No. 67-9, Shir Men Road, Tu Cheng City,
Taipei Hsien

PHONE : 886-2-22608375 FAX : 886-2-22748013

E - mail : hometek@ms15.hinet.net

CERTIFICATE OF COMPLIANCE

EUT : Keyboard Mouse CAT5 Extender

MODEL NO. : KMXXXT, KMXXXR

Receipt Date : 05/15/2007 Final Test Date: 05/31/2007

REPORT # : EB6E024

APPLICANT : SMART CABLING & TRANSMISSION CORP.

ADDRESS : 10F, No. 493, Chung-Cheng Rd.,
Hsin Tien City, Taipei 231, Taiwan, R. O. C.

Measurement procedure used:

- EMI: EN 55022 Class B (1998) + A1 (2000) + A2 (2003),**
EN 61000-3-2 (2000), EN 61000-3-3 (1995) + A1 (2001)
- EMS: EN 55024 (1998) + A1 (2001) + A2 (2003):**
IEC 61000-4-2 (2001), IEC 61000-4-3 (2002), IEC 61000-4-4 (2004), IEC 61000-4-5 (2001),
IEC 61000-4-6 (2003) + A1 (2004), IEC 61000-4-8 (2001), IEC 61000-4-11 (2004)

We hereby show that:

The measurements shown in this test report were made in accordance with the procedures given in **EUROPEAN COUNCIL DIRECTIVE 2004/108/EC**, and the energy emitted by the equipment was found to be within the limits applicable.

This test result of this report applies to above tested sample only.

This test report shall not be reproduce in part without written approval of HomeTek Technology Inc.

APPROVED BY : Alain Lin 6/1/2007

ALAIN LIN / Supervisor



TABLE OF CONTENTS..... 1

GENERAL INFORMATION..... 3

MODIFICATION LIST..... 4

CONDUCTED POWER LINE TEST 5

1 TEST PROCEDURE..... 5

2 RESULT OF CONDUCTED EMISSION TEST..... 5

RADIATED EMISSION TEST..... 6

1 TEST INSTRUMENTS & FACILITIES..... 6

2 TEST PROCEDURE..... 7

3 TEST SETUP 7

4 CONFIGURATION OF THE EUT 9

5 EUT OPERATING CONDITION..... 17

6 LIMIT OF RADIATED EMISSION CLASS B 18

7 RESULT OF RADIATED EMISSION TEST..... 18

8 RADIATED EMISSION TEST DATA (PAGE 1)..... 19

9 RADIATED EMISSION TEST DATA (PAGE 2)..... 20

HARMONICS TEST..... 21

1 TEST PROCEDURE..... 21

2 RESULT OF HARMONICS TEST 21

VOLTAGE FLUCTUATIONS TEST 22

1 TEST PROCEDURE..... 22

2 RESULT OF VOLTAGE FLUCTUATIONS TEST 22

ELECTROSTATIC DISCHARGE IMMUNITY TEST (ESD) 23

1 TEST INSTRUMENTS & FACILITIES..... 23

2 TEST PROCEDURE..... 23

3 TEST SETUP 23

4 CONFIGURATION OF THE EUT 24

5 EUT OPERATION CONDITION..... 24

6 TEST CONDITION 24

7 PERFORMANCE CRITERIA 24

8 TEST RESULT 25

RADIO FREQUENCY ELECTROMAGNETIC FIELD IMMUNITY TEST (RF)..... 26

1 TEST INSTRUMENTS & FACILITIES..... 26

2 TEST PROCEDURE..... 26

3 TEST SETUP 27

4 CONFIGURATION OF THE EUT 28

5 OPERATION CONDITION OF EUT..... 28

6 TEST CONDITION 28



7 PERFORMANCE CRITERIA 28

8 TEST RESULT 29

ELECTRICAL FAST TRANSIENT/BURST IMMUNITY TEST (EFT)..... 30

1 TEST PROCEDURE..... 30

2 RESULT OF ELECTRICAL FAST TRANSIENT/BURST IMMUNITY TEST (EFT) 30

SURGE IMMUNITY TEST 31

1 TEST PROCEDURE..... 31

2 RESULT OF SURGE IMMUNITY TEST 31

IMMUNITY TEST TO CS CONDUCTED DISTURBANCE 32

1 TEST PROCEDURE..... 32

2 RESULT OF SURGE IMMUNITY TEST 32

POWER FREQUENCY MAGNETIC FIELD IMMUNITY TEST 33

1 TEST INSTRUMENTS & FACILITIES..... 33

2 TEST STANDARD 33

3 TEST SETUP 33

4 TEST LEVELS..... 34

5 CONFIGURATION OF THE EUT 34

6 OPERATION CONDITION OF EUT 34

7 CONDITIONS DURING TESTING..... 34

8 PERFORMANCE CRITERIA 34

9 TEST RESULTS 35

VOLTAGE DIPS, SHORT INTERRUPTIONS IMMUNITY TEST..... 36

1 TEST PROCEDURE..... 36

2 RESULT OF VOLTAGE DIPS, SHORT INTERRUPTIONS IMMUNITY TEST 36

APPENDIX A

PHOTOS OF TEST CONFIGURATION

APPENDIX B

PHOTOS OF EUT

GENERAL INFORMATION

- 1 APPLICANT : SMART CABLING & TRANSMISSION CORP.
- 2 ADDRESS : 10F, No. 493, Chung-Cheng Rd.,
Hsin Tien City, Taipei 231, Taiwan, R. O. C.
-
- 3 MANUFACTURER : SMART CABLING & TRANSMISSION CORP.
- 4 ADDRESS : 10F, No. 493, Chung-Cheng Rd.,
Hsin Tien City, Taipei 231, Taiwan, R. O. C.
-
- 5 DESCRIPTION OF EUT :
- EUT : Keyboard Mouse CAT5 Extender
- Model : KMXXXT, KMXXXR
- Serial # : N/A

5.1 The difference between series of models KMXXXT and KMXXXR are as shown below:

| Difference Mode No. | Transmitter | Receiver | Remark |
|------------------------|-------------|----------|---|
| KMXXXT | Yes | No | (1) The first and second "X" represents different system input. |
| KMXXXR | No | Yes | (2) The third "X" represent different accessory. |

The PCB layout is similar. The worst case of EMC test data were shown in this test report.

6 FEATURES OF EUT :

Please refer to user manual or product specification.

MODIFICATION LIST

THE FOLLOWING ACCESSORIES WERE ADDED TO THE EUT DURING TESTING :

NO MODIFICATION BY HOMETEK TECHNOLOGY INC.

CONDUCTED POWER LINE TEST

1 TEST PROCEDURE

According to **EN55022 Class B**.

2 RESULT OF CONDUCTED EMISSION TEST

N/A (Conducted Power Line Test is not applicable to this EUT (Model : KMPT + KMUR)).

RADIATED EMISSION TEST

1 TEST INSTRUMENTS & FACILITIES

The following test Instruments was used during the radiated emission test :

| Item | Instruments /facilities | Specification | Manufacturer | Model # / S/N# | Date of Cal. |
|------|-------------------------|--|-----------------|------------------------|--------------|
| 1 | OPEN AREA TEST SITE | <input checked="" type="checkbox"/> OATS 3 | | | JUL/2006 |
| 2 | EMI TEST RECEIVER | 20Hz ~ 26.5GHz | ROHDE & SCHWARZ | ESMI 845442/006 | FEB/2007 |
| 3 | PRE-AMPLIFIER | 9KHz ~ 3000MHz | ADVANTEST | BB525C 90081001 | OCT/2006 |
| 4 | ANTENNA (BI-LOG) | 25MHz ~ 2GHz | SCHAFFNER | CBL6112B S/N : 2614 | JUN/2006 |
| 5 | Attenuation | 50Ω/6dB | JYE BAO | FAT-N (M-F) 001 | JUL/2006 |
| 6 | Ferrite Clamp | 30 ~ 1000MHz | ADT | FC18 910030 | DEC/2006 |
| 7 | Ferrite Clamp | 30 ~ 1000MHz | HomeTek | HFC 001 | DEC/2006 |
| 8 | Cable | 10m | SUHNER | RG214/U OS3-003 | DEC/2006 |
| 9 | Cable | 14m | BELDEN | 9913 OS3-001 | DEC/2006 |
| 10 | EMI 32 (software) | N/A | AUDIX | 19991013-0923 | N/A |

Note : Items 1 ~ 9 were calibrated within period of 1 year.

2 TEST PROCEDURE

- 2.1 The EUT was test according to **EN55022**.
- 2.2 The radiated test was performed at HomeTek Lab's Open Site III.
- 2.3 The frequency range from 30 MHz to 1 GHz, the measurement were made at 10 meters, with a BI-log antenna.

3 TEST SETUP

3.1 TEST SETUP OF OPEN SITE.

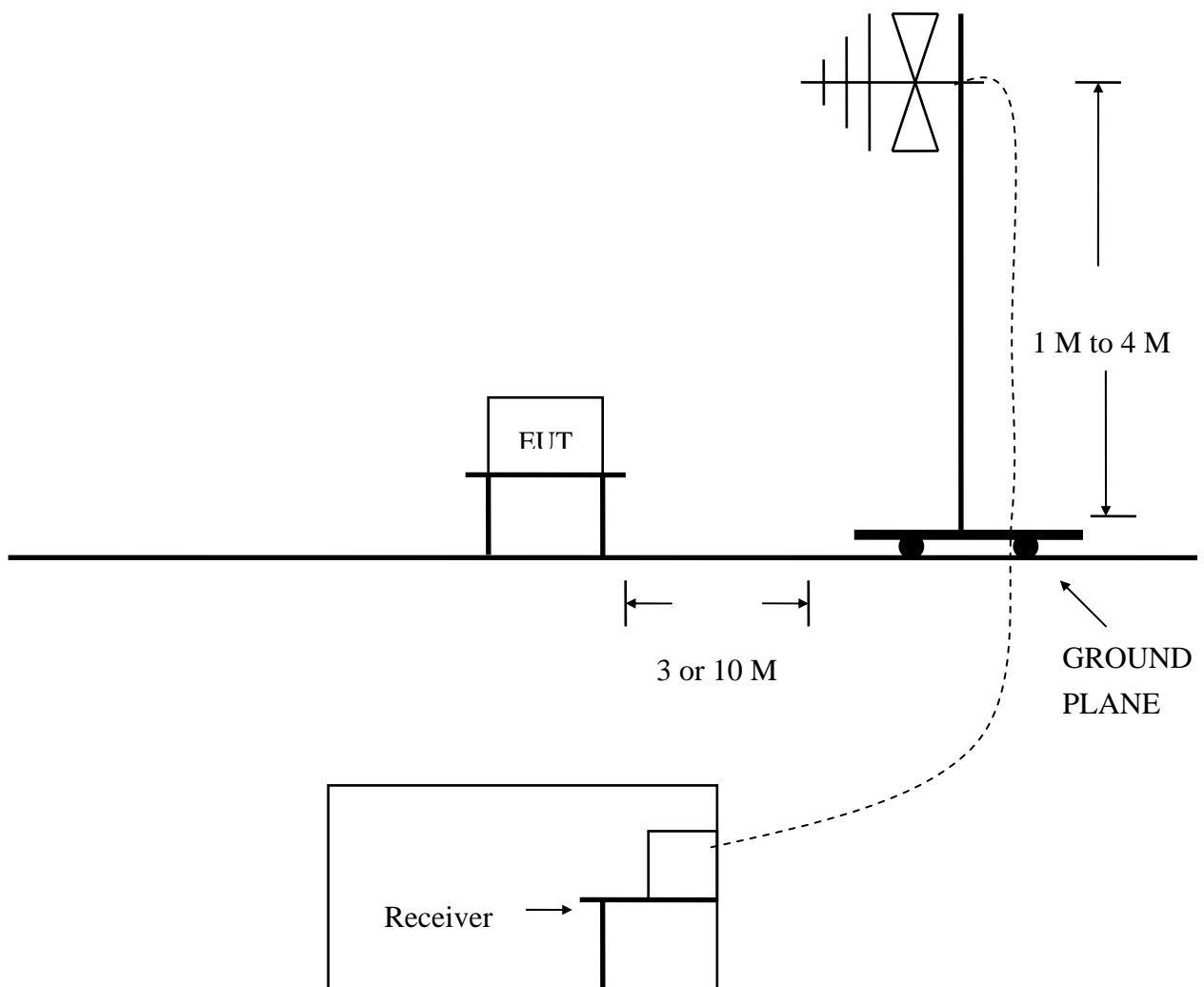

(Details for setup configuration, please refer to appendix A.)

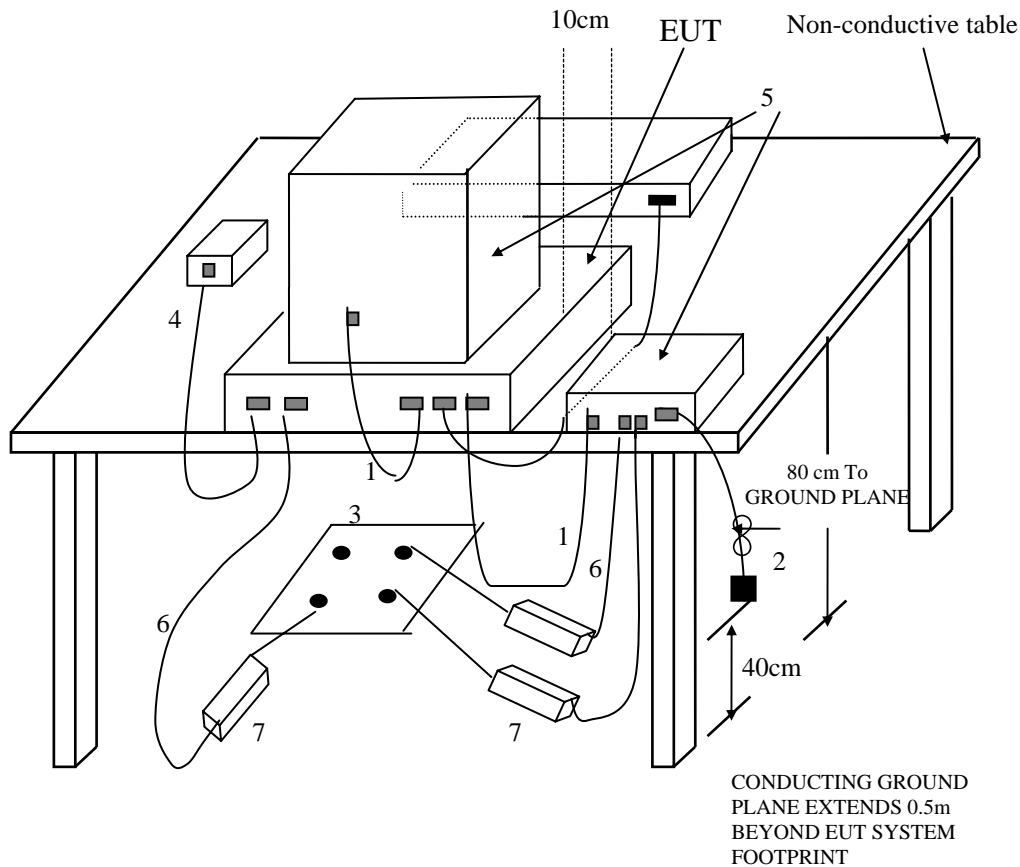

(Details for setup configuration, please refer to appendix A.)

LEGEND:

- 1.If cables, which hang closer than 40 cm to the horizontal metal ground plane cannot be shortened to the appropriate length, the excess shall be folded back and forth forming a bundle 30 cm to 40 cm long.
- 2.The end of I/O signal cables which are not connected to a peripheral may be terminated, if required for proper operation using correct terminating impedance.
- 3.Mains junction box(es) shall be flush with, and bonded directly to, the metal ground plane.
NOTE if used, the AMN shall be installed under the horizontal metal ground plane.
- 4.Cables of hand-operated devices such as keyboards, mice, etc. shall be placed as for normal usage.
- 5.Peripherals shall be placed at a distance of 10 cm from each other and from the controller, except for the monitor which, if for an acceptable installation practice, shall be placed directly on top of the controller.
- 6.Mains cables, telephone lines or other connections to auxiliary equipment located outside the test area shall drape to the floor, be fitted with ferrite clamps or ferrite tubes placed on the floor at the point where the cable reaches the floor and then routed to the place where they leave the turntable. No extension cords shall be used to mains receptacle.
- 7.Ferrite clamps or ferrite tubes with similar characteristics (as defined in 10.4). No more than one cable per clamp.

Test Configuration

Tabletop Equipment Radiated Measurement

4 CONFIGURATION OF THE EUT

The EUT was configured according to **EN55022**. All I/O ports were connected to the appropriate peripherals. All peripherals and cables are listed below (including internal device) :

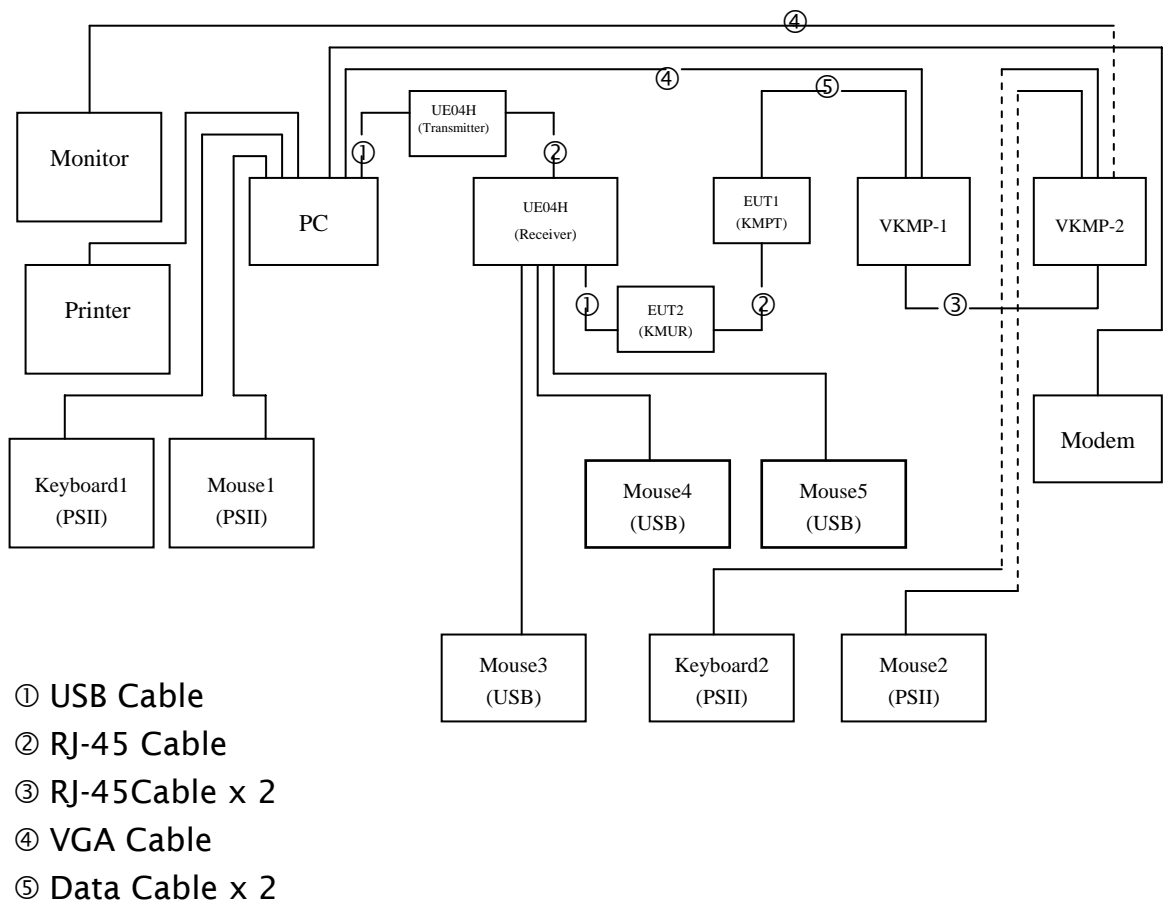

Figure 1



4.1 EUT

EUT Type : Proto Type Engineer Type Mass Production

Condition when received : Good Damage : _____

Device : Keyboard Mouse CAT5 Extender

Applicant : SMART CABLING & TRANSMISSION CORP.

Manufacturer : SMART CABLING & TRANSMISSION CORP.

Model Number : KMXXXT, KMXXXR

Serial Number : N/A

FCC ID : N/A

● KMPT (Transmitter)

Keyboard Port : Metal Type Connector

Mouse Port : Metal Type Connector

RJ-45 Port : Plastic Type Connector

● KMUR (Receiver)

USB Port : Metal Type Connector

RJ-45 Port : Plastic Type Connector

Power Cord : N/A

Power Supply Type : N/A

4.2 PERIPHERALS

Host Personal Computer

Manufacturer : HP/COMPAQ

Model Number : D330UT

Serial Number : SGH40606Z1

FCC ID : FCC DoC

Data Cable 1 : Un-Shielded, 0.18 m, Connect to the USB Port

Data Cable 2 : Shielded, 1.8 m, Connect to the VGA In Port

Power Cord : Un-Shielded, 1.8 m



VGA Card

Manufacturer : ASUS
Model Number : V9999LE/TD/N/128M/A
Serial Number : 59CG018553
FCC ID : N/A
Data Cable : N/A
Power Cord : N/A

Monitor

Manufacturer : SAMSUNG
Model Number : GH19BS
Serial Number : GH19H4JW103538B
FCC ID : FCC DoC
Data Cable : Shielded, 1.8 m, Connected to the VGA Out port
Power Cord : Un-Shielded, 1.8 m

Printer

Manufacturer : HP
Model Number : DJ400
Serial Number : MY7781C1BB
FCC ID : B94C2642X
Data Cable : Shielded, 1.5 m, Connected to the Printer port
Power Cord & Adaptor : Un-Shielded, 1.8 m



Modem

Manufacturer : ACEEX
Model Number : 1414
Serial Number : 9013524
FCC ID : IFAXDM1414
Data Cable : Shielded, 1.5 m, Connected to the COM port
Power Cord & Adaptor : Un-Shielded, 1.8 m

Mouse1 (PSII)

Manufacturer : DELL
Model Number : IntelliMouse 1.3A PS/2 Compatible
Serial Number : 9028603-5
FCC ID : FCC DoC
Data Cable : Shielded, 1.8 m, Connected to the PSII port
Power Cord : N/A

Mouse2 (PSII)

Manufacturer : Microsoft
Model Number : KAZB1
Serial Number : 0720670
FCC ID : C3KAZB1
Data Cable : Shielded, 1.8 m, Connected to the PSII port
Power Cord : N/A



Mouse3 (USB)

Manufacturer : Genius
Model Number : NetScorll
Serial Number : N/A
FCC ID : N/A
Data Cable : Un-Shielded, 1.8 m, Connected to the USB port
Power Cord : N/A

Mouse4 (USB)

Manufacturer : Memorex
Model Number : MP23R-E
Serial Number : N/A
FCC ID : N/A
Data Cable : Un-Shielded, 1.8 m, Connected to the USB port
Power Cord : N/A

Mouse5 (USB)

Manufacturer : Memorex
Model Number : MP23R-E
Serial Number : N/A
FCC ID : N/A
Data Cable : Un-Shielded, 1.8 m, Connected to the USB port
Power Cord : N/A



KeyBoard1 (PSII)

Manufacturer : Monterey
Model Number : K371
Serial Number : H0007057608
FCC ID : FCC DoC
Data Cable : Shielded, 1.5 m, Connected to the PSII port
Power Cord : N/A

KeyBoard2 (PSII)

Manufacturer : ASUS
Model Number : KS-613P
Serial Number : N/A
FCC ID : N/A
Data Cable : Un-Shielded, 1.5 m, Connected to the PSII port
Power Cord : N/A

USB CAT5 extender with 4 port USB hub (Transmitter)

Manufacturer : SMART CABLING & TRANSMISSION CORP.
Model Number : UE04H
Serial Number : N/A
FCC ID : N/A
Data Cable 1 : Un-Shielded, 0.18 m, Connected to the USB port
Data Cable 2 : Un-Shielded, 0.07 m, Connected to the RJ-45 port
Power Cord : N/A



USB CAT5 extender with 4 port USB hub (Receiver)

Manufacturer : SMART CABLING & TRANSMISSION CORP.
Model Number : UE04H
Serial Number : N/A
FCC ID : N/A
Data Cable 1 : Un-Shielded, 0.07 m, Connected to the RJ-45 port
Data Cable 2 x 3 : Un-Shielded, 1.8 m, Connected to the USB port
Data Cable 3 : Un-Shielded, 0.18 m, Connected to the USB port
Power Cord : N/A

VGA Keyboard Mouse CAT5 Extender-1

Manufacturer : SMART CABLING & TRANSMISSION CORP.
Model Number : VKMP
Serial Number : N/A
FCC ID : N/A
Data Cable 1 : Un-Shielded, 0.26 m, Connected to the Keyboard port
Data Cable 2 : Un-Shielded, 0.26 m, Connected to the Mouse port
Data Cable 3 : Shielded, 1.8 m, Connected to the VGA In port
Data Cable 4 : Un-Shielded, 1.8 m, Connected to the RJ1 port
Data Cable 5 : Un-Shielded, 1.8 m, Connected to the RJ2 port
Power Cord : N/A



VGA Keyboard Mouse CAT5 Extender-2

| | |
|---------------|--|
| Manufacturer | : SMART CABLING & TRANSMISSION CORP. |
| Model Number | : VKMP |
| Serial Number | : N/A |
| FCC ID | : N/A |
| Data Cable 1 | : Un-Shielded, 1.5 m, Connected to the Keyboard port |
| Data Cable 2 | : Un-Shielded, 1.8 m, Connected to the Mouse port |
| Data Cable 3 | : Shielded, 1.8 m, Connected to the VGA Out port |
| Data Cable 4 | : Un-Shielded, 1.8 m, Connected to the RJ1 port |
| Data Cable 5 | : Un-Shielded, 1.8 m, Connected to the RJ2 port |
| Power Cord | : N/A |

4.3 REMARK : N/A

5 EUT OPERATING CONDITION

5.1 The frequency of the EUT is none.

5.2 The radiated emission in the frequency range from 30 MHz - 1000 MHz was test in a horizontal and vertical polarization at HomeTek Lab's open site III.

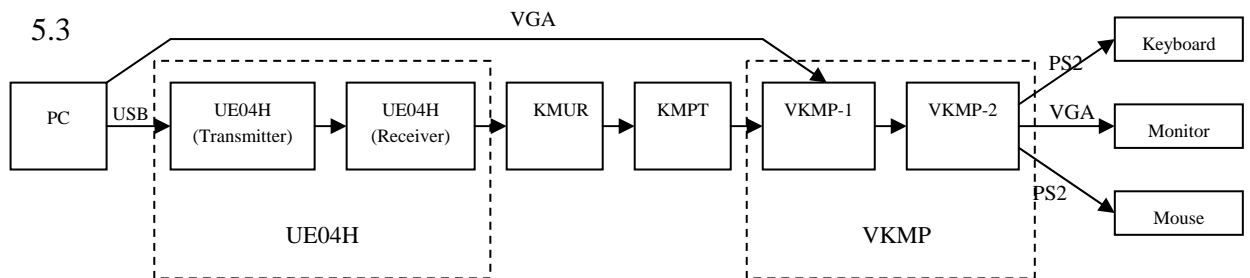

5.4 PC sends VGA signal to VKMP and VKMP change VGA signal.

5.5 During the test, the PC sends “H” patterns to each I/O port individually. (For 1280 x 1024)

5.6 Then has changed VGA signal send to monitor display.

5.7 The photos of radiated test configuration, please refer to appendix A.

6 LIMIT OF RADIATED EMISSION CLASS B

| Frequency (MHz) | Measurement Distance | Limit (dBuV/m) |
|--------------------|-------------------------|----------------|
| 30 - 230 | 10 (M) | 30 |
| 230 - 1000 | 10 (M) | 37 |

7 RESULT OF RADIATED EMISSION TEST

- 7.1 The frequency range from 30 MHz to 1 GHz was investigated.
- 7.2 All readings below or equal 1 GHz are quasi-peak or peak values with resolution bandwidth of 120 KHz.
- 7.3 The measurements were made at 10 meters of HomeTek Lab's open site III.
- 7.4 Temperature : 25 °C, Humidity : 49 % RH.
- 7.5 Deviation form the test standards and rules : None.
- 7.6 The radiated emission result were gained by the following method :
 Level = Reading Level + Probe Factor (Antenna Factor) + Cable Loss – Preamp Factor
 Over Limit = Level – Limit Line
- 7.7 Result : **PASSED**

8 RADIATED EMISSION TEST DATA (PAGE 1)



HomeTek Technology Inc.

No 67-9, Shi-Men Rd., Tu-Chen City,
 Taipei County, Taiwan R.O.C.
 Tel: 02-22608375
 Fax: 02-22748013

Data#: 6 File#: 6e024.emi

Date: 2007-05-31 Time: 09:59:28

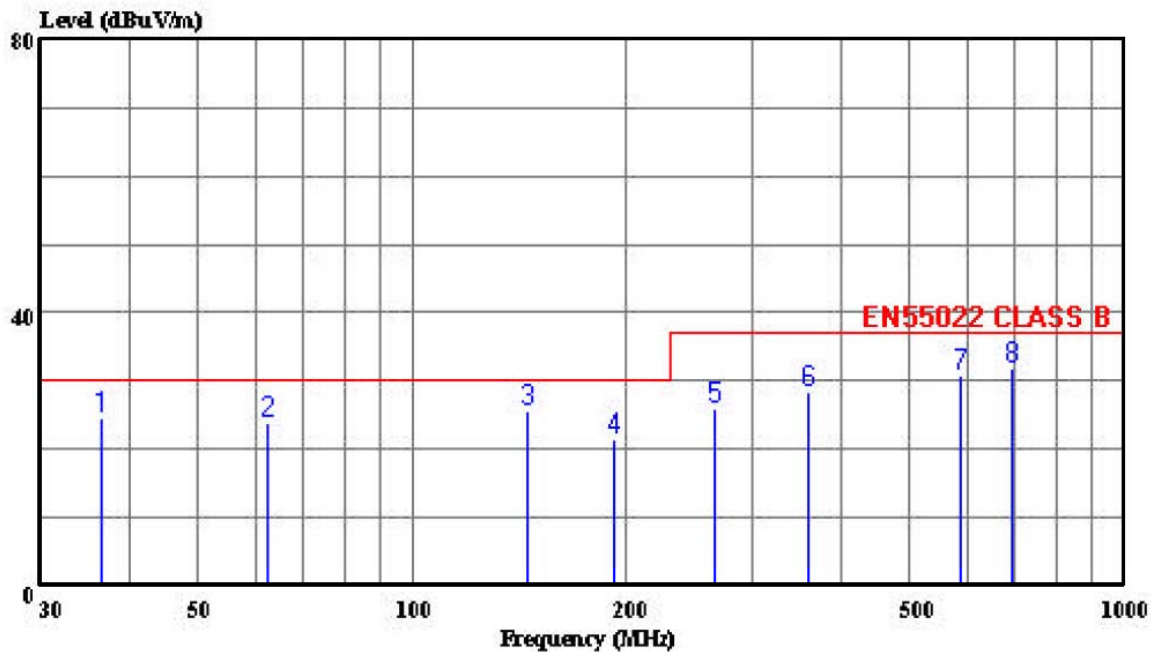

Trace:

Ref Trace:

Condition: EN55022 CLASS B 10m CHASE 2614 060506 HORIZONTAL
 eut : Keyboard Mouse CAT5 Extender
 power: N/A
 memo : KMPT , KMUR

Page: 1

| | Freq | Level | Limit | Over | ReadAntenna | Cable | Preamp | Remark |
|---|---------|--------|--------|--------|-------------|-------|--------|------------|
| | MHz | dBuV/m | Line | Limit | Level | Loss | Factor | |
| | | | dBuV/m | dB | dBuV | dB/m | dB | dB |
| 1 | 36.540 | 24.62 | 30.00 | -5.38 | 34.00 | 15.94 | 0.68 | 26.00 Peak |
| 2 | 62.540 | 23.79 | 30.00 | -6.21 | 42.00 | 6.76 | 0.98 | 25.95 Peak |
| 3 | 145.230 | 25.68 | 30.00 | -4.32 | 39.00 | 10.68 | 1.81 | 25.81 Peak |
| 4 | 192.500 | 21.32 | 30.00 | -8.68 | 36.00 | 8.97 | 2.07 | 25.72 Peak |
| 5 | 265.300 | 26.12 | 37.00 | -10.88 | 36.00 | 13.12 | 2.57 | 25.57 Peak |
| 6 | 360.490 | 28.49 | 37.00 | -8.51 | 36.00 | 14.68 | 3.14 | 25.33 Peak |
| 7 | 589.120 | 30.74 | 37.00 | -6.26 | 31.00 | 18.54 | 5.71 | 24.51 Peak |
| 8 | 697.530 | 31.91 | 37.00 | -5.09 | 32.00 | 18.82 | 5.15 | 24.05 Peak |

9 RADIATED EMISSION TEST DATA (PAGE 2)



HomeTek Technology Inc.

No 67-9, Shi-Men Rd., Tu-Chen City,
 Taipei County, Taiwan R.O.C.
 Tel: 02-22608375
 Fax: 02-22748013

Data#: 5 File#: 6e024.emi

Date: 2007-05-31 Time: 09:26:18

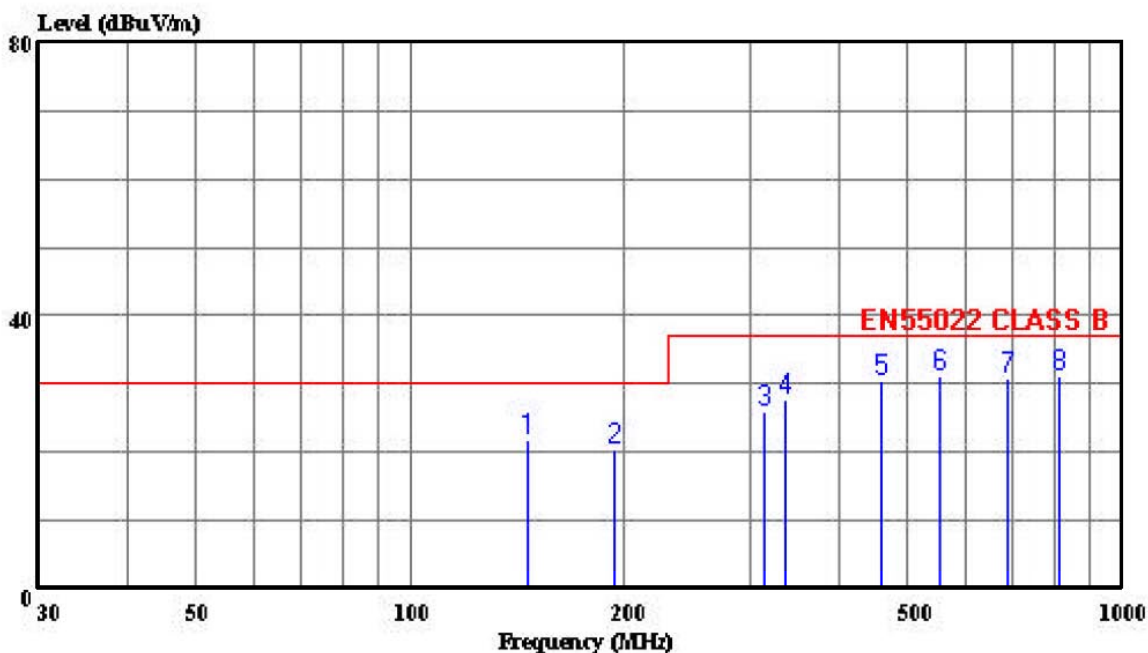

Trace:

Ref Trace:

Condition: EN55022 CLASS B 10m CHASE 2614 060506 VERTICAL
 eut : Keyboard Mouse CAT5 Extender
 power: N/A
 memo : KMPT , KMUR

Page: 1

| | Freq | Level | Limit | Over | ReadAntenna | Cable | Preamp | Remark |
|---|---------|--------|--------|--------|-------------|-------|--------|------------|
| | MHz | dBuV/m | dBuV/m | dB | Level | Loss | Factor | |
| | | | | | dB | dB | dB | |
| 1 | 145.600 | 21.68 | 30.00 | -8.32 | 35.00 | 10.68 | 1.81 | 25.81 Peak |
| 2 | 193.800 | 20.35 | 30.00 | -9.65 | 35.00 | 8.99 | 2.08 | 25.72 Peak |
| 3 | 314.500 | 25.89 | 37.00 | -11.11 | 35.00 | 13.49 | 2.86 | 25.46 Peak |
| 4 | 337.200 | 27.69 | 37.00 | -9.31 | 36.00 | 14.09 | 3.00 | 25.39 Peak |
| 5 | 458.120 | 30.42 | 37.00 | -6.58 | 35.00 | 16.72 | 3.69 | 24.99 Peak |
| 6 | 552.120 | 31.05 | 37.00 | -5.95 | 32.00 | 18.69 | 4.99 | 24.63 Peak |
| 7 | 690.100 | 30.95 | 37.00 | -6.05 | 31.00 | 18.84 | 5.19 | 24.08 Peak |
| 8 | 816.500 | 31.28 | 37.00 | -5.72 | 30.00 | 19.89 | 5.11 | 23.72 Peak |

HARMONICS TEST

1 TEST PROCEDURE

According to **EN 61000-3-2 (2000)**.

2 RESULT OF HARMONICS TEST

N/A (This standard is not applicable to this EUT (Model : KMPT + KMUR)).

VOLTAGE FLUCTUATIONS TEST

1 TEST PROCEDURE

According to **EN 61000-3-3 (1995) + A1 (2001)**.

2 RESULT OF VOLTAGE FLUCTUATIONS TEST

N/A (This standard is not applicable to this EUT (Model : KMPT + KMUR)).

4 CONFIGURATION OF THE EUT

Same as “Radiated Emission test”, section 4

5 EUT OPERATION CONDITION

Same as “Radiated Emission test”, section 5

6 TEST CONDITION

6.1 Test Level :

(A) $\pm 2, 4, 8$ KV for air discharge.

(B) $\pm 2, 4$ KV for contact discharge.

6.2 Number of test : 10 Discharges / Test point / Polarity / Level

Particular requirements : at least 200 discharges, 100 each at negative and positive polarity, at a minimum of four test points.

6.3 Time between test : 1 sec.

6.4 Temperature : 21 °C

6.5 Humidity : 45 % RH.

7 PERFORMANCE CRITERIA

- A. The apparatus shall continue to operate as intended during and after the test. No degradation of performance or loss of function is allowed below a performance level specified by the manufacturer, when the apparatus is used as intended.
- B. The apparatus shall continue to operate as intended after the test. No degradation of performance or loss of function is allowed below a performance level specified by the manufacturer, when the apparatus is used as intended. The performance level may be replaced by a permissible loss of performance. During the test, degradation of performance is however allowed.
- C. Temporary loss of function is allowed, provided the function is self-recoverable or can be restored by the operation of the controls.

8 TEST RESULT

| Test Point | Air Discharge | Contact Discharge | Performance Criteria | Result |
|------------|---------------|-------------------|----------------------|---------------|
| HCP | --- | ±2, 4KV | B | PASSED |
| VCP | --- | ±2, 4KV | B | PASSED |
| CASE | ±2, 4, 8KV | ±2, 4KV | B | PASSED |
| I/O PORTS | ±2, 4, 8KV | ±2, 4KV | B | PASSED |
| LED | ±2, 4, 8KV | ±2, 4KV | B | PASSED |
| SCREWS | ±2, 4, 8KV | ±2, 4KV | B | PASSED |

※ The screen was flash during the test. After the test, EUT resume automatically.

9 Photos of test configuration please refer to appendix A.

RADIO FREQUENCY ELECTROMAGNETIC FIELD IMMUNITY TEST (RS)

1 TEST INSTRUMENTS & FACILITIES

| Item | Instruments Facilities | Manufacturer | Model # Serial # | Data Of Cal. |
|------|---------------------------|-----------------------|---------------------|--------------|
| 1 | SIGNAL GENERATOR | ROHDE & SCHWARZ | SMY02 845181/025 | MAR/2007 |
| 2 | AMPLIFIER | AMPLIFIER RESEARCH | 100W1000M1A | N/A |
| 3 | FIELD SENSOR | AMPLIFIER RESEARCH | FP2000 | AUG/2006 |
| 4 | FIELD MONITOR | AMPLIFIER RESEARCH | FM2000 | AUG/2006 |
| 5 | RF VOLTMETER | BOONTON | 9200C 361701AA | MAR/2007 |
| 6 | RF PROBE | BOONTON | 952001B 37082 | MAR/2007 |
| 7 | DIRECTION COUPLER | AMPLIFIER RESEARCH | DC6180 20521 | N/A |
| 8 | ANTENNA | EMCO | 3142B S/N: 1789 | N/A |
| 9 | CONTROL PC | KB TECH | KB P586/133 | -- |

Note : Items 3 ~ 4 were calibrated with two years and verified before testing.

2 TEST PROCEDURE

According to **IEC 61000-4-3 (2002)**

According to **EN 55024 (1998) + A1 (2001) + A2 (2003)**

3 TEST SETUP

FERRITE TILE

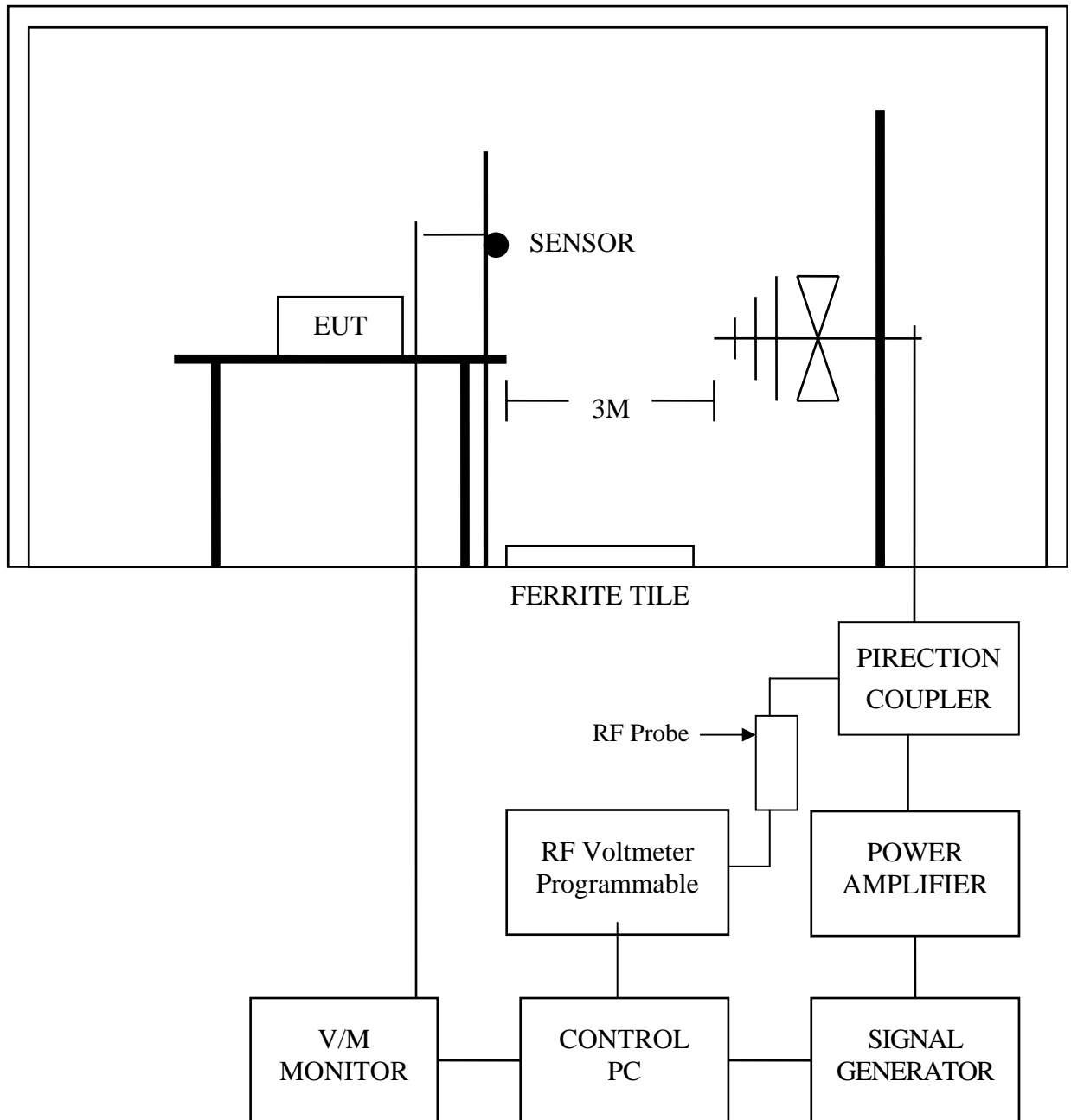

3.1 Chamber Size :

12M x 5M x 5M

(Details for setup configuration, please refer to appendix A.)

4 CONFIGURATION OF THE EUT

Same as “Radiated Emission test”, section 4

5 OPERATION CONDITION OF EUT

Same as “Radiated Emission test”, section 5

6 TEST CONDITION

6.1 Frequency Range : 80 MHz ~ 1000 MHz

(Frequency Range : 1.4 GHz ~ 2.0 GHz is not applicable for EN55024:1998+A1:2001+A2:2003)

6.2 Filed Strength : 3 V / M (1KHz 80% Modulation)

6.3 Frequency Step : 1 %, 3 sec. / each step size

6.4 Antenna Polarity : HORIZONTAL & VERTICAL

6.5 The four sides of EUT are tested
(FRONT, REAR, RIGHT, LEFT)

6.6 Temperature : 23 °C

6.7 Humidity : 50 % RH

7 PERFORMANCE CRITERIA

- A. The apparatus shall continue to operate as intended during and after the test. No degradation of performance or loss of function is allowed below a performance level specified by the manufacturer, when the apparatus is used as intended.
- B. The apparatus shall continue to operate as intended after the test. No degradation of performance or loss of function is allowed below a performance level specified by the manufacturer, when the apparatus is used as intended. The performance level may be replaced by a permissible loss of performance. During the test, degradation of performance is however allowed.
- C. Temporary loss of function is allowed, provided the function is self-recoverable or can be restored by the operation of the controls.

8 TEST RESULT

| ANT SIDE | HORIZONTAL | VERTICAL | RESULT |
|-------------|------------|----------|--------|
| FRONT | A | A | PASSED |
| REAR | A | A | PASSED |
| RIGHT | A | A | PASSED |
| LEFT | A | A | PASSED |

9 Photos of test configuration please refer to appendix A.

ELECTRICAL FAST TRANSIENT/BURST IMMUNITY TEST (EFT)

1 TEST PROCEDURE

According to **IEC 61000-4-4 (2004)**

According To **EN 55024 (1998) + A1 (2001) + A2 (2003)**

2 RESULT OF ELECTRICAL FAST TRANSIENT/BURST IMMUNITY TEST (EFT)

N/A (This standard is not applicable to this EUT (Model : KMPT + KMUR)).

SURGE IMMUNITY TEST

1 TEST PROCEDURE

According To **IEC 61000-4-5 (2001)**

According To **EN 55024 (1998) + A1 (2001) + A2 (2003)**

2 RESULT OF SURGE IMMUNITY TEST

N/A (This standard is not applicable to this EUT (Model : KMPT + KMUR)).

IMMUNITY TEST TO CS CONDUCTED DISTURBANCE

1 TEST PROCEDURE

According To **IEC 61000-4-6 (2003) + A1 (2004)**

According To **EN 55024 (1998) + A1 (2001) + A2 (2003)**

2 RESULT OF SURGE IMMUNITY TEST

N/A (This standard is not applicable to this EUT (Model : KMPT + KMUR)).

POWER FREQUENCY MAGNETIC FIELD IMMUNITY TEST

1 TEST INSTRUMENTS & FACILITIES

| Instruments/ Facilities | Manufacturer | Model # Serial # | Data Of Cal. |
|-----------------------------------|--------------|-------------------------|--------------|
| LINE INTERFERENCE TESTER | HAEFELY | PLINE 1610 080166-10 | FEB/2007 |
| MAGNETIC FIELD TESTER | HAEFELY | MAG 100.1 080206-01 | N/A |
| TRIAXIAL ELF MAGNETIC FIELD METER | F.W.BELL | 4080 9645 | AUG/2006 |
| CONTROL PC | KB TECH | KB P586/133 | -- |

2 TEST STANDARD

According To **IEC 61000-4-8 (2001)**

According To **EN 55024 (1998) + A1 (2001) + A2 (2003)**

3 TEST SETUP

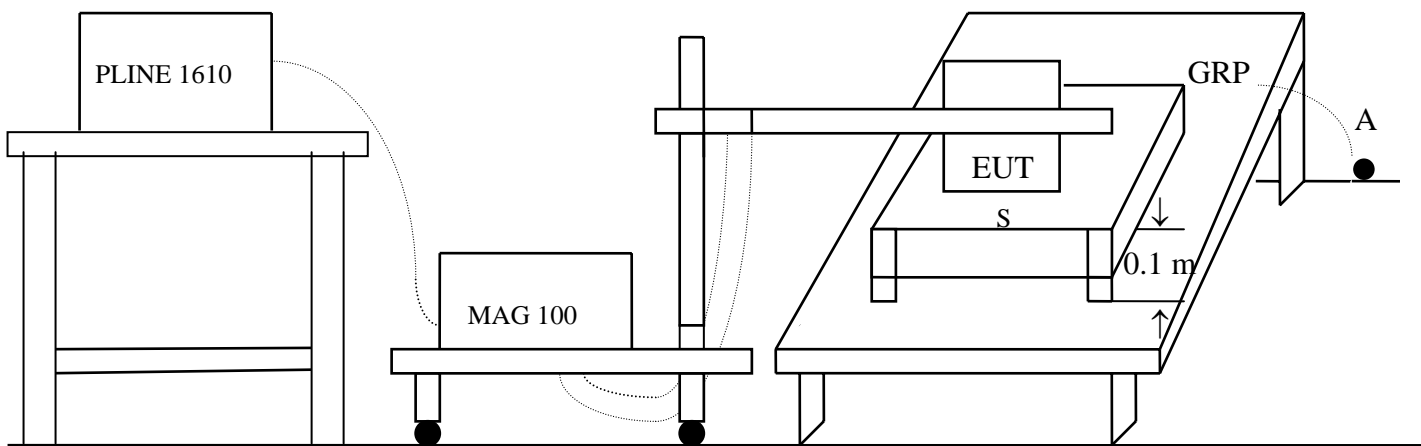

S: Insulating support

A: Safety earth

GRP: Ground plane

(Details for setup configuration, please refer to appendix A.)

4 TEST LEVELS

| Environmental Phenomena | Test Specification | Units | Performance Criteria |
|-------------------------|--------------------|-------|----------------------|
| Power Frequency | 50 | HZ | |
| Magnetic Field | 1 | A/m | B |

5 CONFIGURATION OF THE EUT

Same as “Radiated Emission test”, section 4

6 OPERATION CONDITION OF EUT

Same as “Radiated Emission test”, section 5

7 CONDITIONS DURING TESTING

7.1 Temperature : 24 °C (15°C ~ 35°C)
 Humidity : 54 % RH.(25 % ~ 75%)

7.2 The induction coil shall be rotated by 90°

8 PERFORMANCE CRITERIA

- A. The apparatus shall continue to operate as intended during and after the test. No degradation of performance or loss of function is allowed below a performance level specified by the manufacturer, when the apparatus is used as intended.
- B. The apparatus shall continue to operate as intended after the test. No degradation of performance or loss of function is allowed below a performance level specified by the manufacturer, when the apparatus is used as intended. The performance level may be replaced by a permissible loss of performance. During the test, degradation of performance is however allowed.
- C. Temporary loss of function is allowed, provided the function is self-recoverable or can be restored by the operation of the controls.

9 TEST RESULTS

| Environmental Phenomena | Test Specification | Units | Performance Criteria |
|-------------------------|--------------------|-------|----------------------|
| Magnetic Field | 1 | A/m | A |

9.1 Model : KMPT + KMUR

9.2 Final Result : PASSED

9.3 Remark :

10 Photos of test configuration please refer to appendix A.

VOLTAGE DIPS, SHORT INTERRUPTIONS IMMUNITY TEST

1 TEST PROCEDURE

According To **IEC 61000-4-11 (2004)**

According To **EN 55024 (1998) + A1 (2001) + A2 (2003)**

2 RESULT OF VOLTAGE DIPS, SHORT INTERRUPTIONS IMMUNITY TEST

N/A (This standard is not applicable to this EUT (Model : KMPT + KMUR)).



HomeTek Technology Inc.

Appendix A

PHOTOS OF TEST CONFIGURATION

PHOTO OF RADIATED EMISSION TEST

Model : KMUR , KMPT



Front View



Rear View

PHOTO OF RADIO FREQUENCY ELECTROMAGNETIC FIELD IMMUNITY TEST (RS)

Model : KMUR , KMPT



PHOTO OF ELECTROSTATIC DISCHARGE IMMUNITY TEST (ESD)



PHOTO OF POWER FREQUENCY MAGNETIC FIELD IMMUNITY TEST

Model : KMUR , KMPT





HomeTek Technology Inc.

Appendix B

PHOTOS OF EUT

PHOTO OF EUT



Full View of EUT(Model : KMUR)

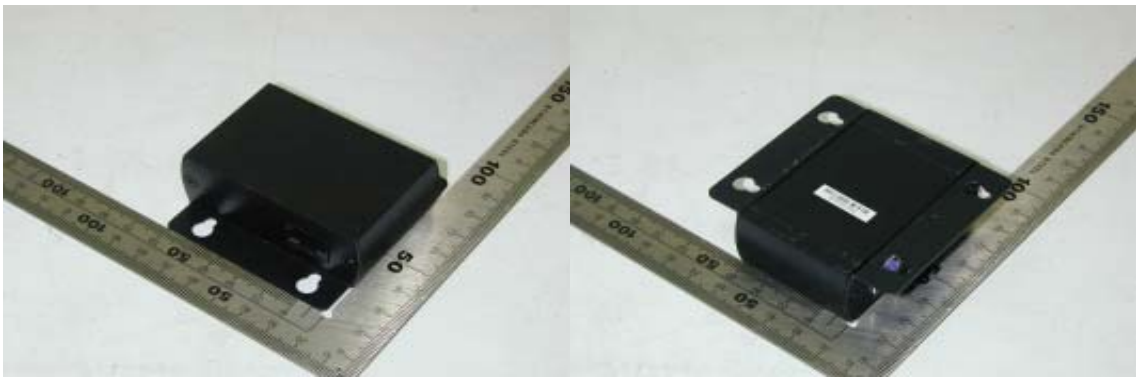

Full View of EUT(Model : KMPT)

PHOTO OF EUT



Full View of EUT(Model : KMUR)



Full View of EUT(Model : KMPT)

PHOTO OF EUT

Model :KMXXXR

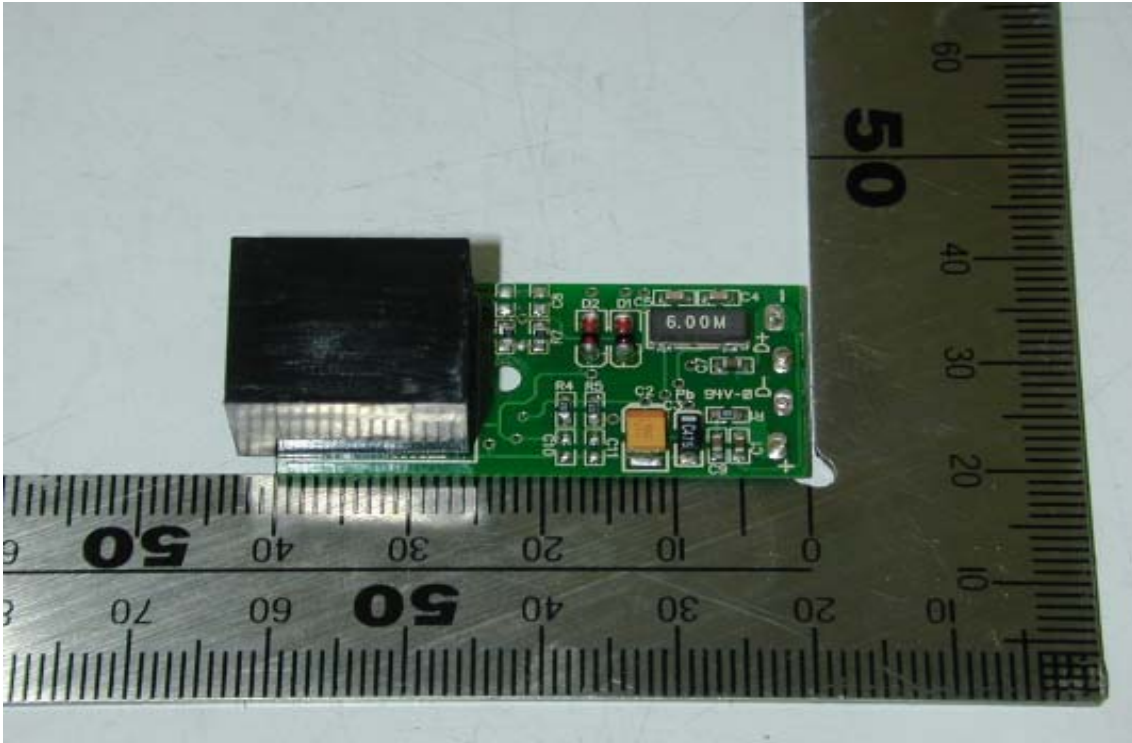

Component Side of Main Board 1

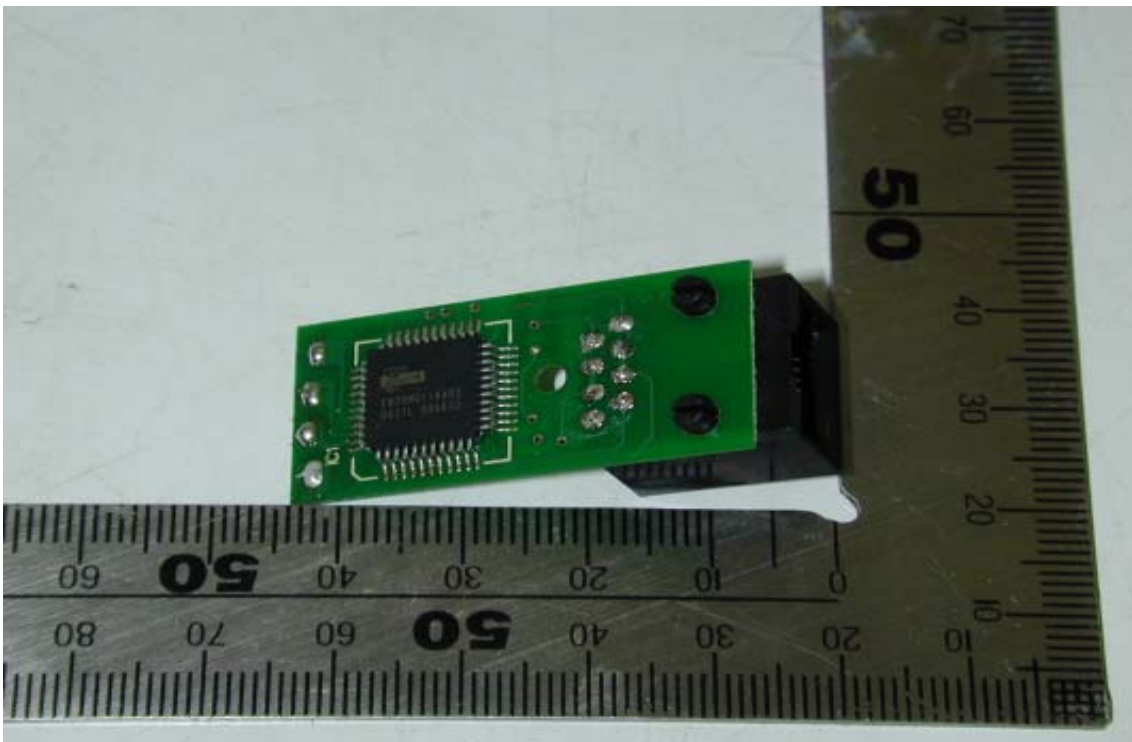

Solder Side of Main Board 1

PHOTO OF EUT

Model : KMXXXT

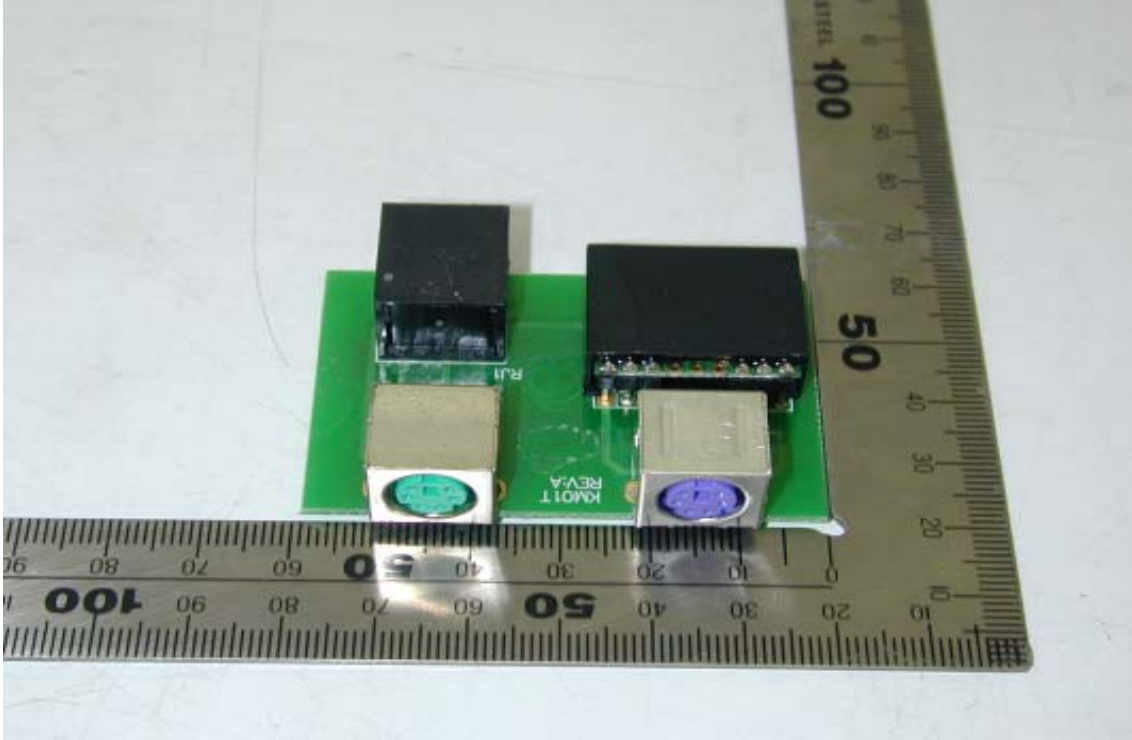

Component Side of Main Board 2

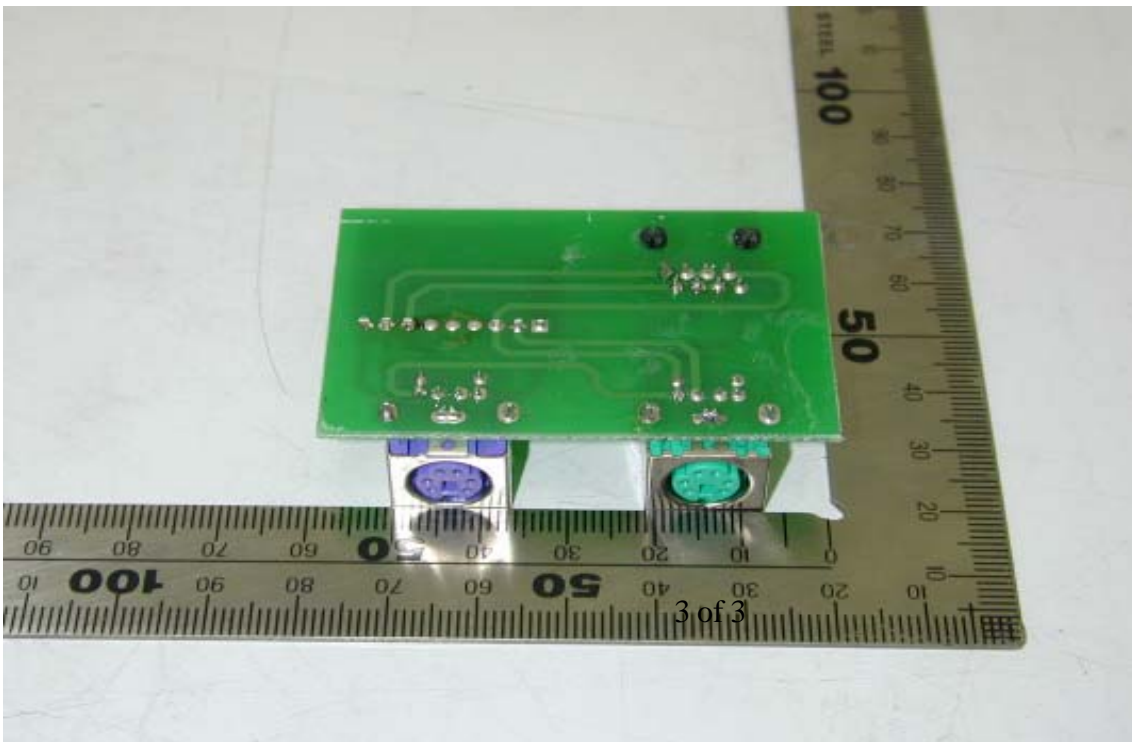

Solder Side of Main Board 2

Declaration of Conformity

We(Manufacturer/Importer)

(company name)

(address)

declares under our sole responsibility that the product

Product name : Keyboard Mouse CAT5 Extender

Model No. : KMXXXT, KMXXXR

to which this declaration relates is in conformity with the following standard(s) or other normative document(s)

- | | |
|---|---|
| <input checked="" type="checkbox"/> EN 55022 Class B (1998) | <input checked="" type="checkbox"/> EN 55024 (1998) |
| + A1 (2000) | + A1 (2001) |
| + A2 (2003) | + A2 (2003) |
| <input checked="" type="checkbox"/> EN 61000-3-2 (2000) | <input checked="" type="checkbox"/> IEC 61000-4-2 (2001) |
| <input checked="" type="checkbox"/> EN 61000-3-3 (1995) | <input checked="" type="checkbox"/> IEC 61000-4-3 (2002) |
| + A1 (2001) | <input checked="" type="checkbox"/> IEC 61000-4-4 (2004) |
| | <input checked="" type="checkbox"/> IEC 61000-4-5 (2001) |
| | <input checked="" type="checkbox"/> IEC 61000-4-6 (2003) |
| | + A1 (2004) |
| | <input checked="" type="checkbox"/> IEC 61000-4-8 (2001) |
| | <input checked="" type="checkbox"/> IEC 61000-4-11 (2004) |

following the provisions of 2004/108/EC Directive

Place: _____ Signature: _____

Date : _____ Full name: _____



Title: _____



TÜV Rheinland Taiwan Ltd.

Certificate

of

Appointment

for the applicant:

Hometek Technology Inc.
No. 67-9, Shir Men Rd., Tu-Cheng City,
Taipei Hsien 236, Taiwan, R.O.C.

has been authorized to carry out EMC tests by order and under supervision of TÜV Rheinland. It has successfully demonstrated capability to conduct measurement and to process test data according to:

**European and International EMC Standards as listed in the
Scope of Authorization on the attachment to this certificate**

An assessment of the facility was conducted by TÜV Rheinland auditors according to the TÜV Rheinland requirements for "Test Site Approval" with reference to

ISO 17 025:1999

Certificate No. : 10012161-2006

Valid until : June 14, 2007

TÜV Rheinland Taiwan Ltd.
Taipei, April 13, 2006

Dipl.-Ing. Andreas Klinker
Certification Body

Dipl.-Ing. Bodo Kretzschmar
Product Safety and Quality



Attachment to
Certificate
of Appointment

SCOPE OF AUTHORIZATION

Hometek Technology Inc.
No. 67-9, Shir Men Rd., Tu-Cheng City,
Taipei Hsien 236, Taiwan, R.O.C.

European Standards

| | | |
|--------------|---------------|-----------|
| EN 50081-1 | EN 61000-3-2 | ENV 50140 |
| EN 50081-2 | EN 61000-3-3 | ENV 50141 |
| EN 50082-1 | EN 61000-6-1 | ENV 50204 |
| EN 50130-4 | EN 61000-6-2 | |
| EN 50091-2 | EN 61000-6-3 | |
| EN 55011 | EN 61000-6-4 | |
| EN 55013 | EN 61000-3-11 | |
| EN 55014-1 | EN 61000-4-2 | |
| EN 55014-2 | EN 61000-4-3 | |
| EN 55022 | EN 61000-4-4 | |
| EN 55024 | EN 61000-4-5 | |
| EN 60601-1-2 | EN 61000-4-6 | |
| EN 60801 | EN 61000-4-8 | |
| EN 60945 | EN 61000-4-11 | |
| | EN 61204-3 | |

International Standards

| | | |
|------------|----------------|----------------|
| CISPR 11 | IEC 61000-4-2 | IEC 61000-3-2 |
| CISPR 13 | IEC 61000-4-3 | IEC 61000-3-3 |
| CISPR 14-1 | IEC 61000-4-4 | IEC 61000-3-11 |
| CISPR 14-2 | IEC 61000-4-5 | IEC 61000-6-1 |
| CISPR 22 | IEC 61000-4-6 | IEC 61000-6-2 |
| CISPR 24 | IEC 61000-4-8 | IEC 61000-6-3 |
| | IEC 61000-4-11 | IEC 61000-6-4 |
| IEC 801.2 | IEC 61000-4-12 | IEC 60945 |
| IEC 801.3 | | |
| IEC 801.4 | | |

Certificate No. : 10012161-2006

Taipei, April 13, 2006

Dipl.-Ing. Bodo Kretzschmar
Product Safety and Quality