

HomeTek Technology Inc.

ADDRESS: No. 67-9, Shir Men Road, Tu Cheng City,
Taipei Hsien, Taiwan, R. O. C.

PHONE : 886-2-22608375 FAX : 886-2-22748013

E - mail : hometek@ms15.hinet.net

FCC TEST REPORT FOR

APPLICANT : SMART CABLING & TRANSMISSION CORP.
 ADDRESS : 7F-1, No. 168, Lien Cheng Rd.,
Chung-Ho City, Taipei Hsien, Taiwan, R. O. C.
 EUT : Power Converter
 MODEL NO. : PC1XXX



NVLAP Lab Code:200331-0

Accredited by the National Voluntary Laboratory Accreditation Program
for the specific scope of accreditation under Lab Code 200331-0

MEASUREMENT PROCEDURE USED

FCC RULES AND CISPR 22 (DOCKET NO. 92-152, SEP. 1993) AND FCC / ANSI C63.4-2001

PREPARED BY :

HomeTek Technology Inc.

No. 67-9, Shir Men Road, Tu Cheng City,
Taipei Hsien. Taiwan, R. O. C.

Report # : FD4A027



TABLE OF CONTENTS.....2

VERIFICATION.....3

GENERAL INFORMATION.....4

MODIFICATION LIST.....5

CONDUCTED POWER LINE TEST.....6

 1 TEST PROCEDURE.....6

 2 RESULT OF CONDUCTED EMISSION TEST6

RADIATED EMISSION TEST.....7

 1 TEST INSTRUMENTS & FACILITIES7

 2 TEST PROCEDURE.....8

 3 TEST SETUP8

 4 CONFIGURATION OF THE EUT.....10

 5 EUT OPERATING CONDITION.....13

 6 LIMIT OF RADIATED EMISSION CLASS B13

 7 RESULT OF RADIATED EMISSION TEST14

 8 RADIATED EMISSION TEST DATA (PAGE 1).....15

 9 RADIATED EMISSION TEST DATA (PAGE 2).....16

SAMPLE OF FCC LABEL..... 17

APPENDIX A

PHOTOS OF TEST CONFIGURATION

APPENDIX B

PHOTOS OF EUT



ADDRESS: No. 67-9, Shir Men Road, Tu Cheng City,
 Taipei Hsien, Taiwan, R. O. C.
 PHONE : 886-2-22608375 FAX : 886-2-22748013
 E - mail : hometek@ms15.hinet.net



VERIFICATION

for

FCC Part 15, Subpart B Class B

APPLICANT : SMART CABLING & TRANSMISSION CORP.
 ADDRESS : 7F-1, No. 168, Lien Cheng Rd.,
Chung-Ho City, Taipei Hsien, Taiwan, R. O. C.
 Receipt Date : 01/12/2005 Final Test Date: 01/26/2005
 EUT : Power Converter
 MODEL NO. : PC1XXX

MEASUREMENT PROCEDURE USED :

FCC RULES AND CISPR 22 (DOCKET NO. 92-152, SEP. 1993)
 AND FCC / ANSI C63.4-2001

TEST PROCEDURE AND DATA ARE TRACEABLE TO NIST/USA,
 TL or NML/TAIWAN.

- THE MAXIMUM EMISSION LEVELS WERE COMPARED TO THE CISPR 22 CLASS B LIMITS BOTH RADIATED AND CONDUCTED EMISSION.
- THE ABOVE DEVICE WAS TESTED BY HOMETEK TECHNOLOGY INC. TO SHOWS THE MAXIMUM EMISSION LEVEL FROM THE DEVICE.
- THIS TEST RESULTS OF THIS REPORT APPLIES TO ABOVE TESTED SAMPLE ONLY.
- THIS TEST REPORT SHALL NOT BE REPRODUCE IN PART WITHOUT WRITTEN APPROVAL OF HOMETEK TECHNOLOGY INC.
- THE REPORT MUST NOT BE USED BY THE CLIENT TO CLAIM PRODUCT ENDORSEMENT BY NVLAP OR ANY AGENCY OF THE U. S. GOVERNMENT.
- THE TEST RESULTS ARE TRACEABLE TO THE NATIONAL OR INTERNATIONAL STANDARD.

PREPARED BY : Mingyu Li DATE : 2/1/2005
 MING YU LI

CHECK BY : Albert Tsai DATE : 2/2/2005
 ALBERT TSAI / Senior Engineer

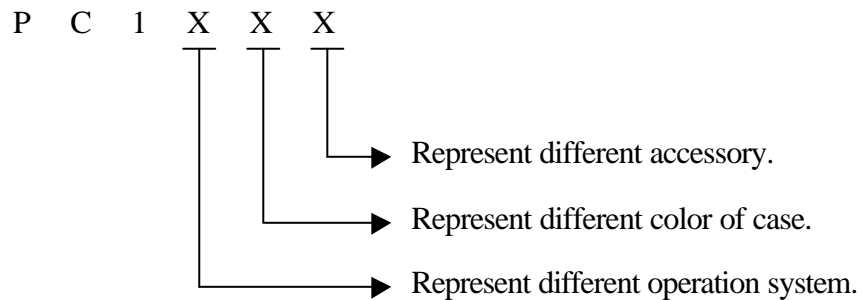
APPROVED BY : Tommy Rau DATE : 2/2/2005
 TOMMY RAU / Manager



GENERAL INFORMATION

- 1 APPLICANT : SMART CABLING & TRANSMISSION CORP.
- 2 ADDRESS : 7F-1, No. 168, Lien Cheng Rd.,
Chung-Ho City, Taipei Hsien, Taiwan, R. O. C.
- 3 MANUFACTURER : SMART CABLING & TRANSMISSION CORP.
- 4 ADDRESS : 7F-1, No. 168, Lien Cheng Rd.,
Chung-Ho City, Taipei Hsien, Taiwan, R. O. C.
- 5 DESCRIPTION OF EUT :
 - EUT : Power Converter
 - FCC ID : N/A
 - Model Number : PC1XXX
 - Serial # : N/A

5.1 The difference between series of models PC1XXX is shown as below:



The worst case of EMI test model is PC1A and the final test data were shown in this test report.

6 FEATURES OF EUT :

Please refer to user manual or product specification.



HomeTek Technology Inc.

MODIFICATION LIST

THE FOLLOWING ACCESSORIES WERE ADDED TO THE EUT DURING TESTING :

NO MODIFICATION BY HOMETEK TECHNOLOGY INC.



CONDUCTED POWER LINE TEST

1 TEST PROCEDURE

According to **ANSI C63.4 - 2001 & CISPR 22.**

2 RESULT OF CONDUCTED EMISSION TEST

N/A (Conducted Power Line Test is not applicable to this EUT (Model : PC1A)).



RADIATED EMISSION TEST

1 TEST INSTRUMENTS & FACILITIES

The following test Instruments was used during the radiated emission test :

Item	Instruments /facilities	Specification	Manufacturer	Model # / S/N#	Date of Cal.
1	OPEN AREA TEST SITE	<input checked="" type="checkbox"/> OATS 3			JUL/2004
2	EMI TEST RECEIVER	30MHz ~ 1GHz	ROHDE & SCHWARZ	ESVS10 845165/017	SEP/2004
3	RF SPECTRUM ANALYZER	N/A	HEWLETT PACKARD	8591E 3710A06158	MAY/2004
4	PRE-AMPLIFIER	9KHz ~ 3000MHz	ADVANTEST	BB525C 90081001	SEP/2004
5	ANTENNA (BI-LOG)	25MHz ~ 2GHz	SCHAFFNER	CBL6112B S/N : 2614	MAY/2004
6	Attenuation	50 /6dB	JYE BAO	FAT-N (M-F) 001	JUL/2004
7	Cable	10m	SUHNER	RG214/U OS3-003	DEC/2004
8	Cable	14m	BELDEN	9913 OS3-001	DEC/2004
9	EMI 32 (software)	N/A	AUDIX	19991013-0923	N/A

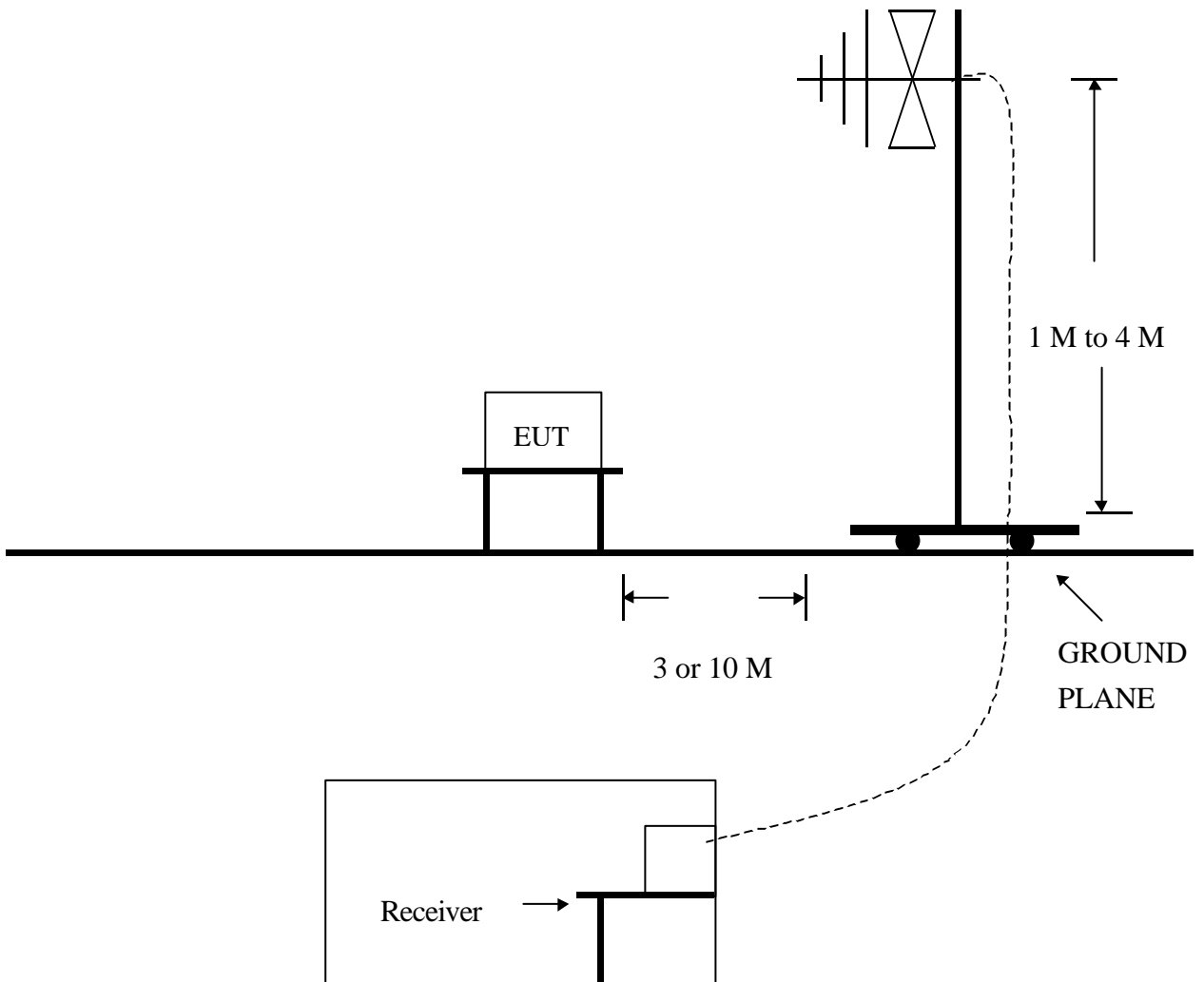
Note : Items 1 ~ 8 were calibrated within period of 1 year.

2 TEST PROCEDURE

- 2.1 The EUT was test according to **ANSI C63.4 - 2001 & CISPR 22**.
- 2.2 The radiated test was performed at HomeTek Lab' s Open Site **III**.
- 2.3 The frequency range from **30** MHz to **1** GHz, the measurement were made at **10** meters, with a BI-log antenna.

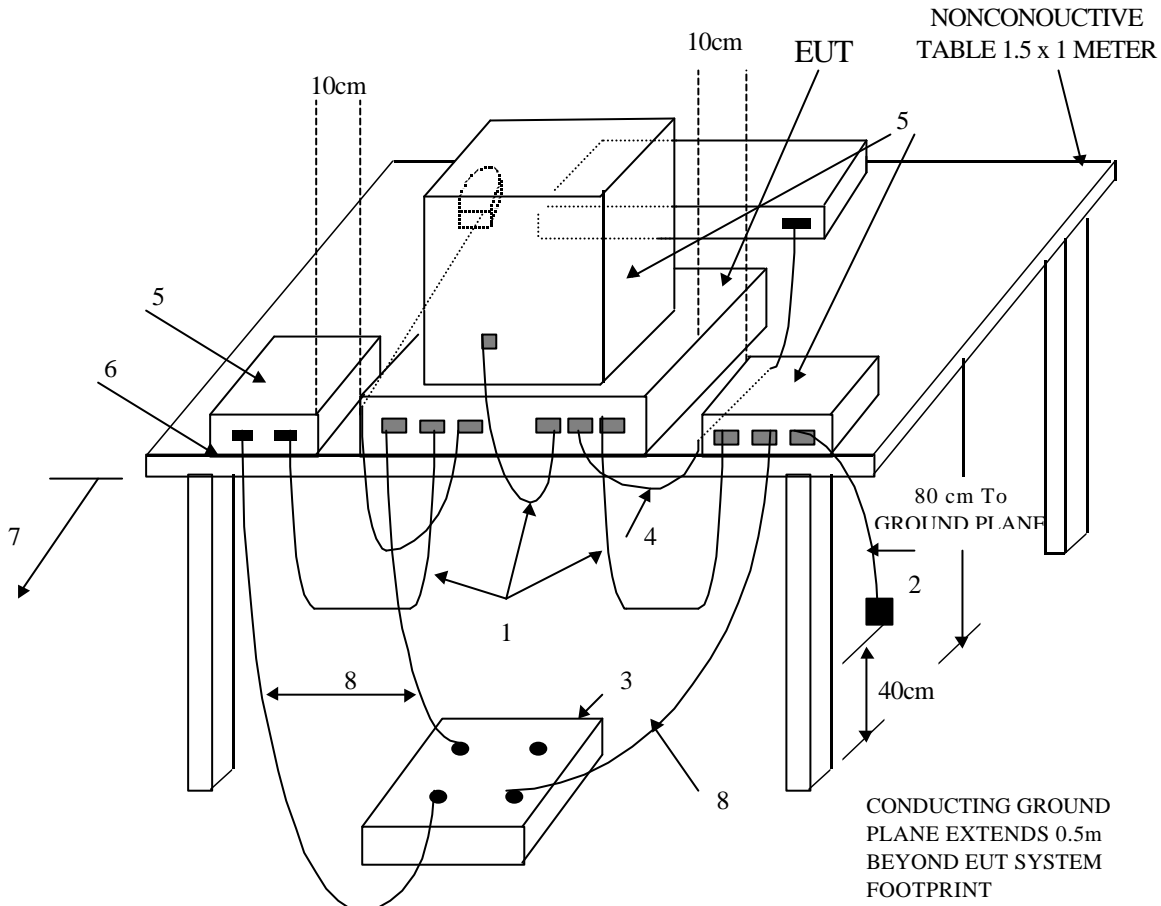
3 TEST SETUP

3.1 TEST SETUP OF OPEN SITE.



3.2 TEST SETUP OF EUT

ELECTRICAL AND ELECTRONIC EQUIPMENT IN THE RANGE OF 9kHz TO 40 GHz ANSI C63.4-2001



(Details for setup configuration, please refer to appendix A.)

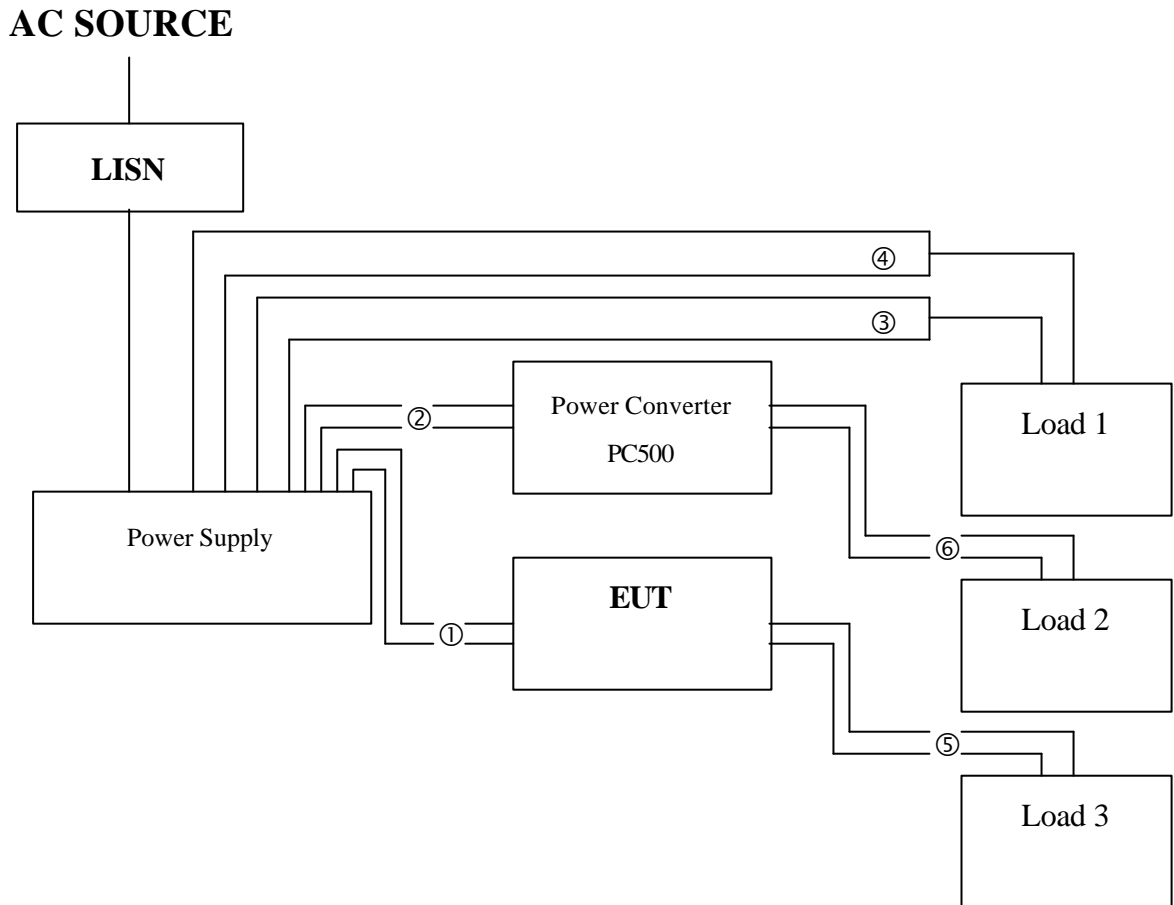
LEGEND:

1. Interconnecting cables that hang closer than 40 cm to the ground plane shall be folded back and forth forming a bundle 30 to 40 cm long, hanging approximately in the middle between ground plane and table.
2. I/O cables that are connected to a peripheral shall be bundled in center. The end of the cable may be terminated if required using correct terminating impedance. The total length shall not exceed 1m.
3. If LISNs are kept in the test setup for radiated emissions, it is preferred that they be installed under the ground plane with the receptacle flush with the ground plane.
4. Cables of hand-operated devices, such as keyboards, mice, etc., have to be placed as close as possible to the controller.
5. Non-EUT components of EUT system being tested.
6. The rear of all components of the system under test shall be located flush with the rear of the table.
7. No vertical conducting wall used.
8. Power cords drape to the floor and are routed over to receptacle.

**Test Configuration
Tabletop Equipment Radiated Emission**

4 CONFIGURATION OF THE EUT

The EUT was configured according to **ANSI C63.4 - 2001 & CISPR 22**. All I/O ports were connected to the appropriate peripherals. All peripherals and cables are listed below (including internal device) :



- ① DC,+ , - Power Cable Output (DC 24V)
- ② DC,+ , - Power Cable Output (DC 24V, To PC500)
- ③ DC,+ Power Cable Output (DC 24V) x 6
- ④ DC,- Power Cable Output (DC 24V) x 6
- ⑤ DC,+ , - Power Cable Output (DC 12V, To Load)
- ⑥ DC,+ , - Power Cable Output (DC 12V, To Load)

Figure 1



4.1 EUT

EUT Type : Proto Type Engineer Type Mass Production
Condition when received : Good Damage : _____
Device : Power Converter
Applicant : SMART CABLING & TRANSMISSION CORP.
Manufacturer : SMART CABLING & TRANSMISSION CORP.
Model Number : PC1XXX
Serial Number : N/A
FCC ID : N/A
Data Cable : N/A
Power Cord (DC 24V) : Un-Shielded, 1 m, 2 pin
Power Cord (DC 12V) : Un-Shielded, 0.5 m, 2 pin
Power Supply Type : From Power Supply

4.2 PERIPHERALS

Power Supply
Manufacturer : SMART CABLING & TRANSMISSION CORP.
Model Number : PW408
Serial Number : N/A
FCC ID : N/A
Data Cable : N/A
Power Cord 1 : Un-Shielded, 1.8 m
Power Cord 2 : Un-Shielded, 1 m



Load 1

Manufacturer : HomeTek
Specification : DC 24V / 12R / 60W
Power Cord : Un-Shielded, 0.5 m

Power Converter

Manufacturer : SMART CABLING & TRANSMISSION CORP.
Model Number : PC500
Serial Number : N/A
FCC ID : N/A
Data Cable : N/A
Power Cord : Un-Shielded, 1 m

Load 2 from PC500 (DC 24V Mode)

Manufacturer : HomeTek
Specification : DC 24V / 24R / 60W
Power Cord : Un-Shielded, 1 m

Load 3 from Power Supply PW408 (DC 24V Mode)

Manufacturer : HomeTek
Specification : DC 24V / 9.6R / 60W
Power Cord : Un-Shielded, 1 m

4.3 REMARK : N/A



5 EUT OPERATING CONDITION

- 5.1 The operation frequency of the EUT is 52 KHz.
- 5.2 Configure the EUT according to the **ANSI C63.4 - 2001 & CISPR 22**.
- 5.3 Connect AC 110V power to input port of Support Unit1(Power Supply PW408).
- 5.4 DC24V output port of Support Unit1(Power Supply PW408) Connect to input port of EUT and input port of Support Unit2(Power Converter PC500) and dummy load(9.6R/60W Resistor)
- 5.5 DC12V output port of EUT connect to dummy load(12R/60W Resistor)
- 5.6 DC12V output port of Support Unit2(Power Converter PC500) connect to dummy load(24R/60W Resistor)
- 5.7 Monitor the status of output port of EUT during the test (For EMS Testing)
- 5.8 The photos of conducted test configuration, please refer to appendix A.**

6 LIMIT OF RADIATED EMISSION CLASS B

CISPR 22

Frequency (MHz)	Measurement Distance	Limit (dBuV/m)
30 - 230	10 (M)	30
230 - 1000	10 (M)	37

- 6.1 The tighter limit shall apply at the edge between two frequency bands.
- 6.2 Measurement distance in meters between the measuring instrument antenna and the closed point of any part of the EUT or peripherals.



7 RESULT OF RADIATED EMISSION TEST

- 7.1 The frequency range from 30 MHz to 1 GHz was investigated.
- 7.2 All readings below or equal 1 GHz are quasi-peak or peak values with resolution bandwidth of 120 KHz.
- 7.3 All readings above 1 GHz are average or peak values with resolution bandwidth of 1 MHz
- 7.4 The measurements were made at 10 meters of HomeTek Lab's open site III.
- 7.5 Temperature : 33 , Humidity : 55 % RH.
- 7.6 Deviation form the test standards and rules : None
- 7.7 The radiation emission result were gained by the following method :
Level = Reading Level + Probe Factor (Antenna Factor) + Cable Loss – Preamp Factor
Over Limit = Level – Limit Line
- 7.8 The radiated mission test was passed at minimum margin :
Vertical 110.63 MHz/ 20.95 dBuV/m, Antenna Height 1.5 Meter,
Turn Table 75 degree, The Model : PC1A.
- 7.9 Result : **PASSED**

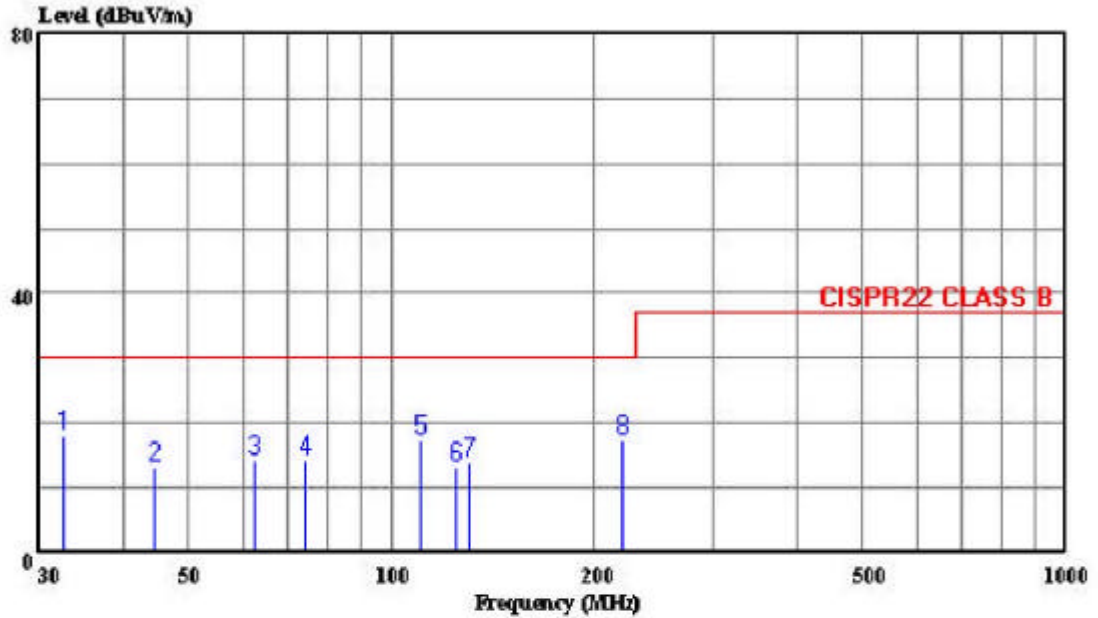


HomeTek Technology Inc.

No 67-9, Shi-Men Rd., Tu-Chen City,
 Taipei County, Taiwan R.O.C.
 Tel:02-22609375
 Fax:02-22748013

Data#: 2 File#: 4a027.emi

Date: 2005-01-18 Time: 15:45:49



Trace:

Ref Trace:

Condition: CISPR22 CLASS B 10m CHASE 2614 052604 HORIZONTAL

cut : Power Converter (PC1A)

power: FROM Power Supply (110V/60Hz)

memo :

Page: 1

	Freq	Level	Limit	Over	ReadAntenna	Cable	Preamp		
	MHz	dBuV/m	dBuV/m	dB	Level	Loss	Factor	Remark	
					Factor	Factor			
					dB/m	dB	dB		
1	32.514	18.04	30.00	-11.96	30.52	16.62	0.79	29.89	Peak
2	44.370	13.02	30.00	-16.98	31.16	10.85	0.90	29.89	Peak
3	62.374	14.31	30.00	-15.69	37.27	5.66	1.04	29.66	Peak
4	74.517	14.18	30.00	-15.82	36.26	6.26	1.13	29.47	Peak
5	110.270	17.47	30.00	-12.53	33.69	11.51	1.38	29.10	Peak
6	124.520	13.31	30.00	-16.69	29.48	11.56	1.46	29.18	Peak
7	130.524	13.77	30.00	-16.23	30.14	11.36	1.49	29.22	Peak
8	220.170	17.22	30.00	-12.78	36.25	8.56	2.02	29.60	Peak

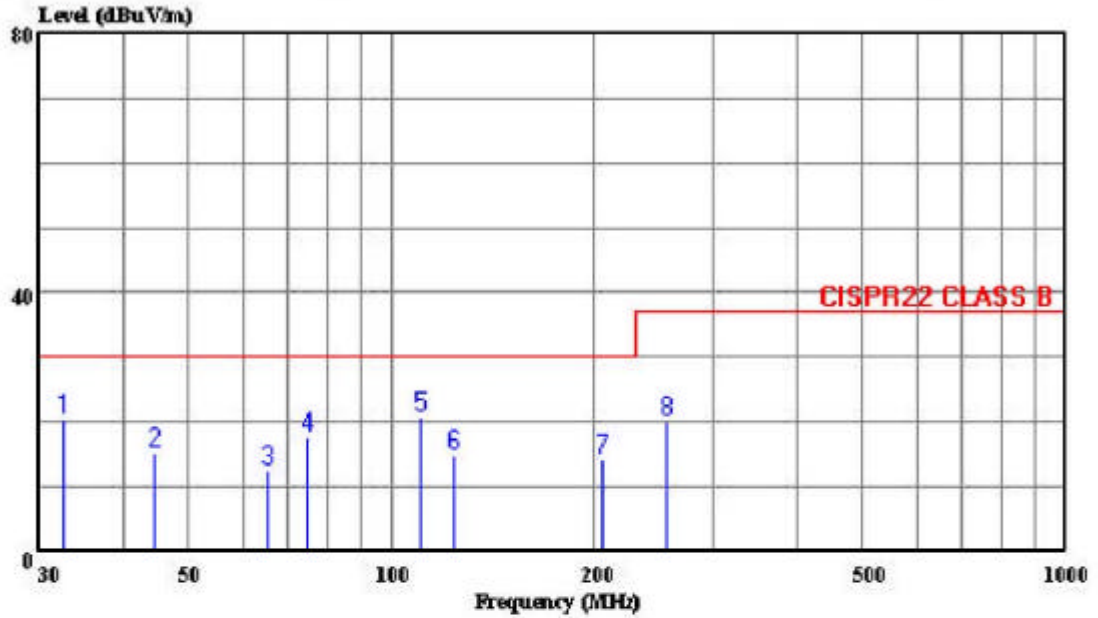


HomeTek Technology Inc.

No 67-9, Shi-Men Rd., Tu-Chen City, Taipei County, Taiwan R.O.C.
Tel:02-22608375
Fax:02-22748013

Data#: 1 File#: 4a027.emi

Date: 2005-01-18 Time: 15:15:46



Trace:

Ref Trace:

Condition: CISPR22 CLASS B 10m CHASE 2614 052604 VERTICAL
cut : Power Converter (PC1A)
power: FROM Power Supply (110V/60Hz)
memo :

Page: 1

	Freq	Level	Limit	Over	ReadAntenna	Cable	Preamp		
	MHz	dBuV/m	dBuV/m	dB	Level	Factor	Loss	Factor	Remark
					dBuV	dB/m	dB	dB	
1	32.540	20.54	30.00	-9.46	33.02	16.62	0.79	29.89	Peak
2	44.362	15.22	30.00	-14.78	33.36	10.85	0.90	29.89	Peak
3	65.374	12.45	30.00	-17.55	35.37	5.63	1.06	29.62	Peak
4	74.956	17.61	30.00	-12.39	39.62	6.32	1.13	29.46	Peak
5	110.637	20.95	30.00	-9.05	37.16	11.51	1.38	29.10	Peak
6	123.320	14.92	30.00	-15.08	31.05	11.60	1.45	29.18	Peak
7	205.743	14.29	30.00	-15.71	33.36	8.62	1.93	29.61	Peak
8	255.164	20.19	37.00	-16.81	35.51	12.00	2.25	29.56	Peak



SAMPLE OF FCC LABEL

This device complies with part 15 of the FCC Rules.
Operation is subject to the following two conditions: (1)
This device may not cause harmful interference. And (2)
this device must accept any interference received, including
interference that may cause undesired operation.



HomeTek Technology Inc.

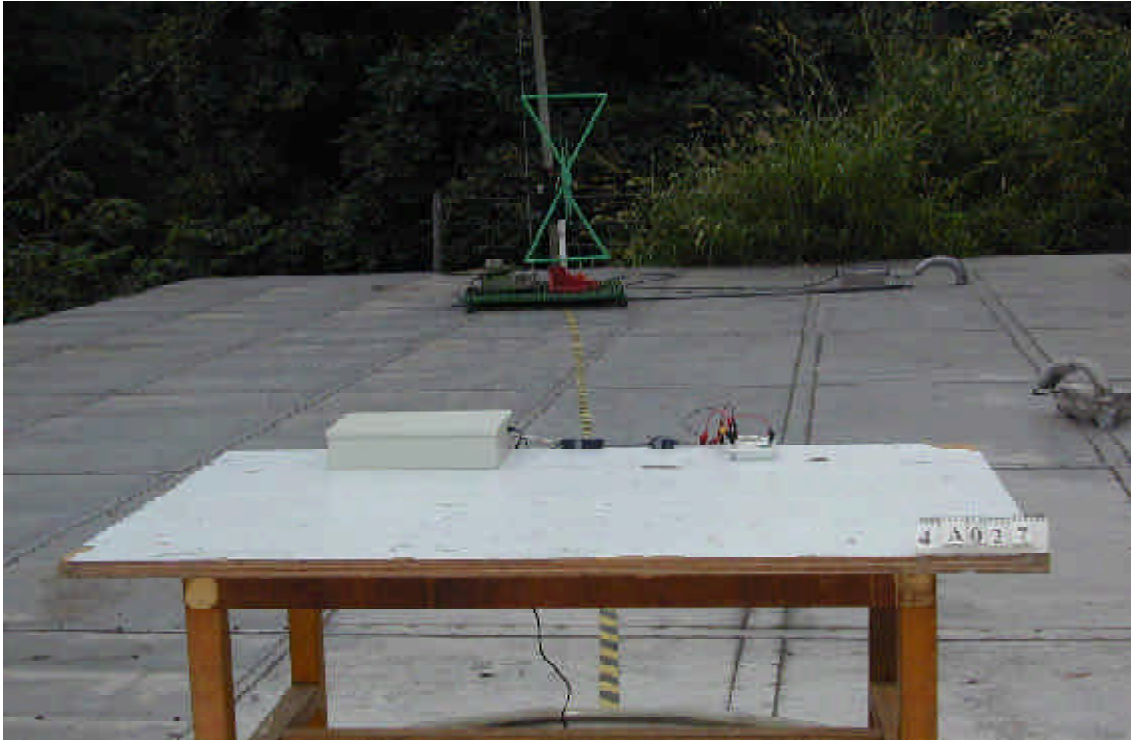
Appendix A

PHOTOS OF TEST CONFIGURATION

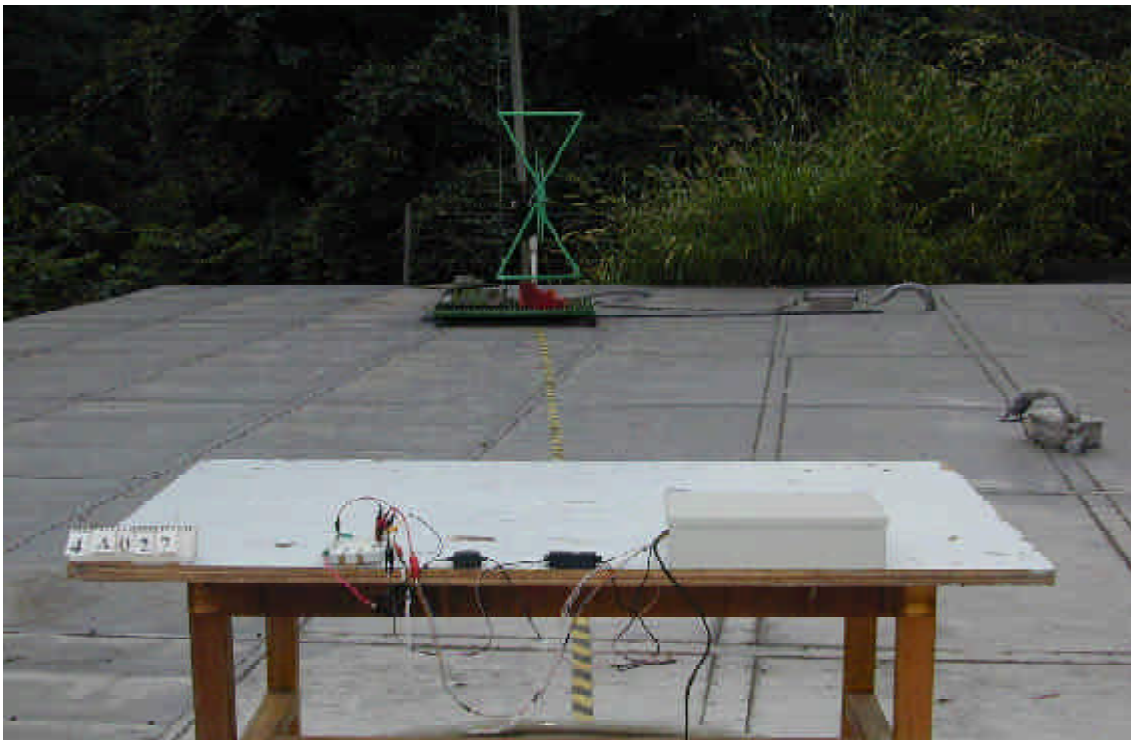


PHOTO OF RADIATED EMISSION TEST

Model: PC1A



Front View



Rear View

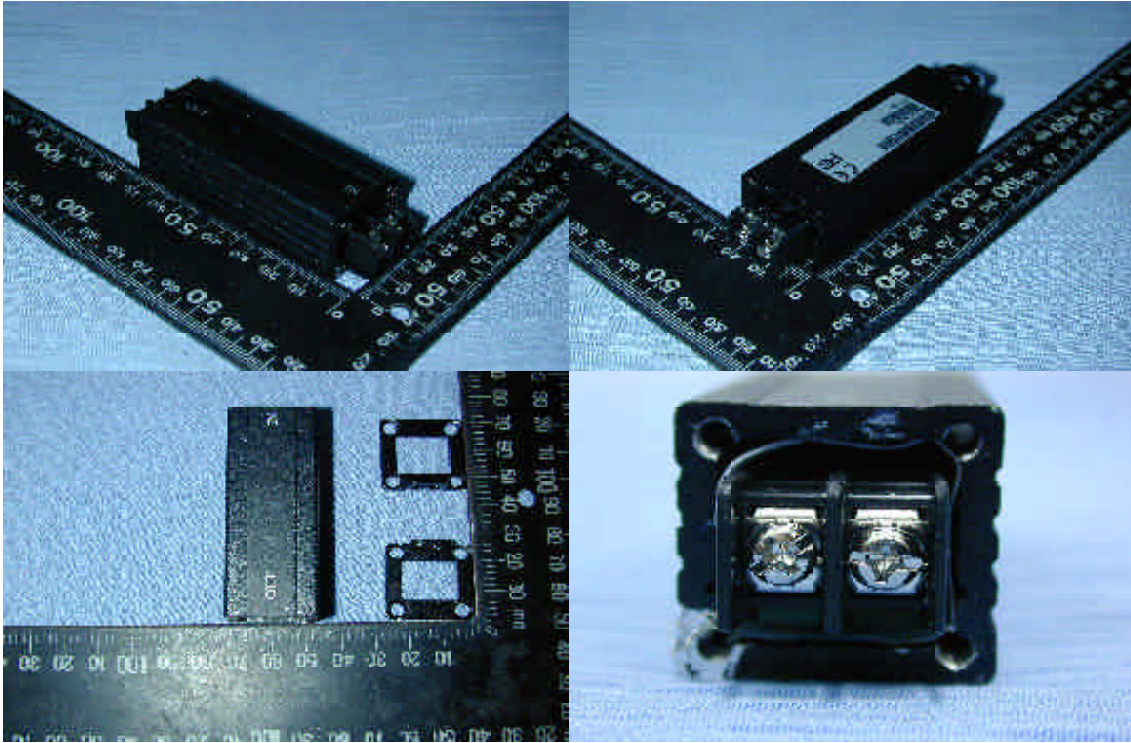


HomeTek Technology Inc.

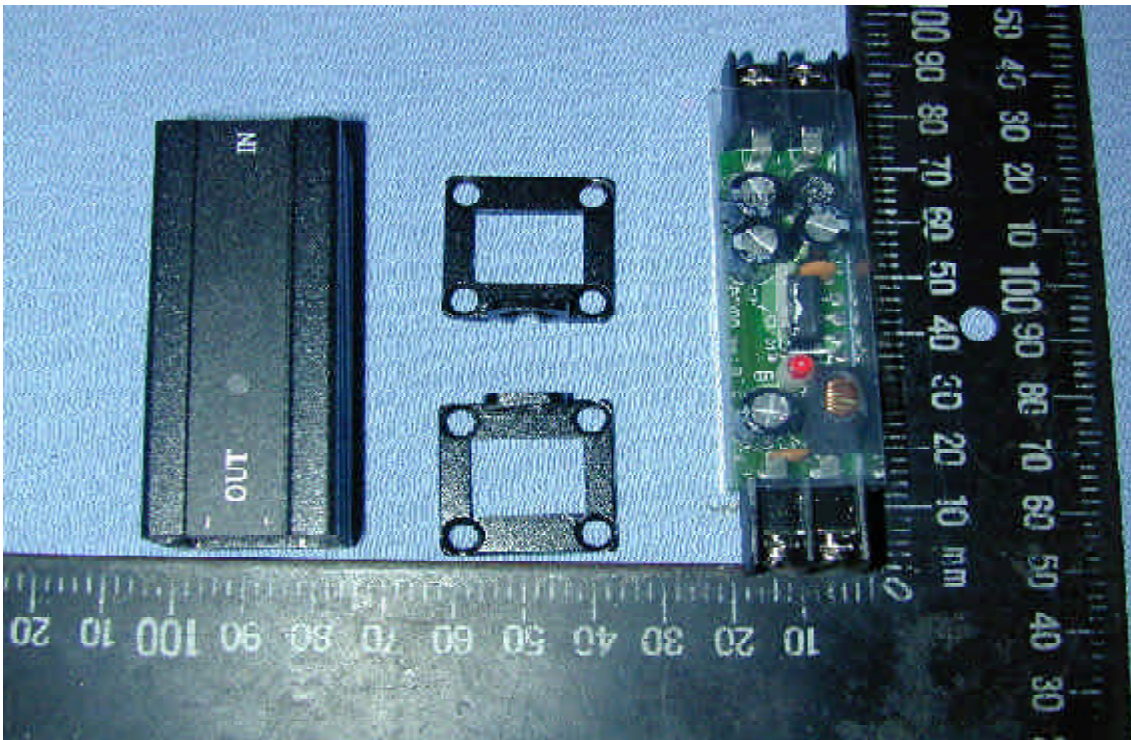
Appendix B
PHOTOS OF EUT

PHOTO OF EUT

Model : PC1A



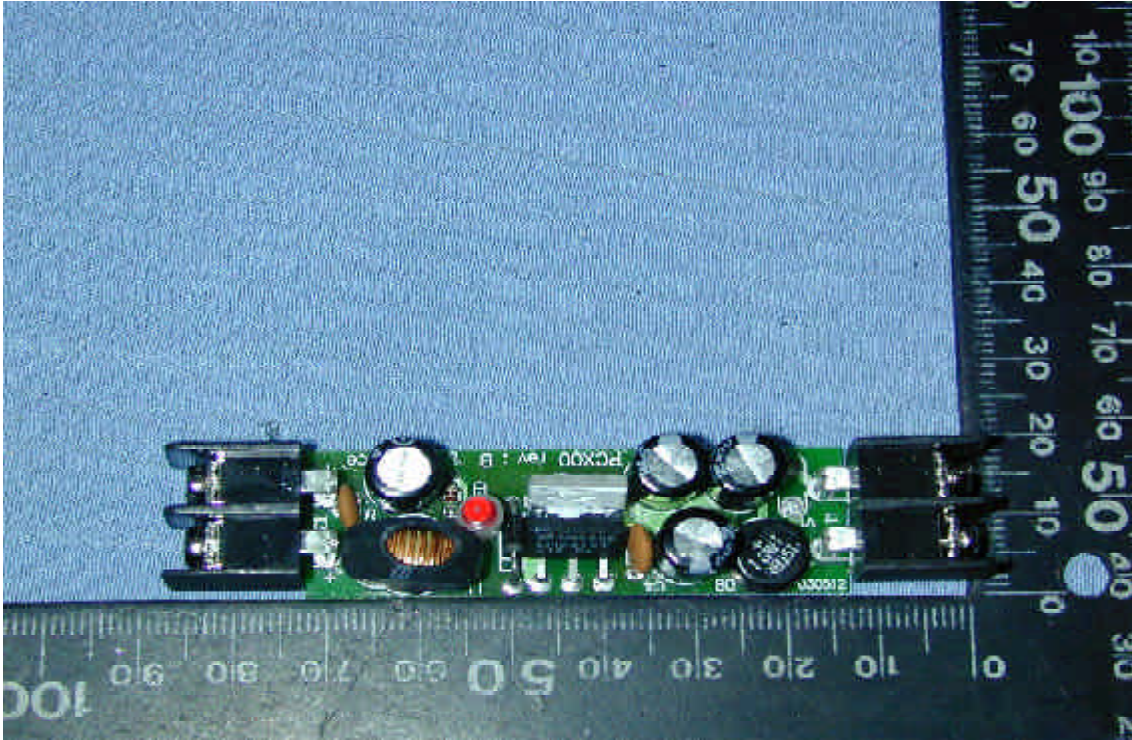
Full View of EUT



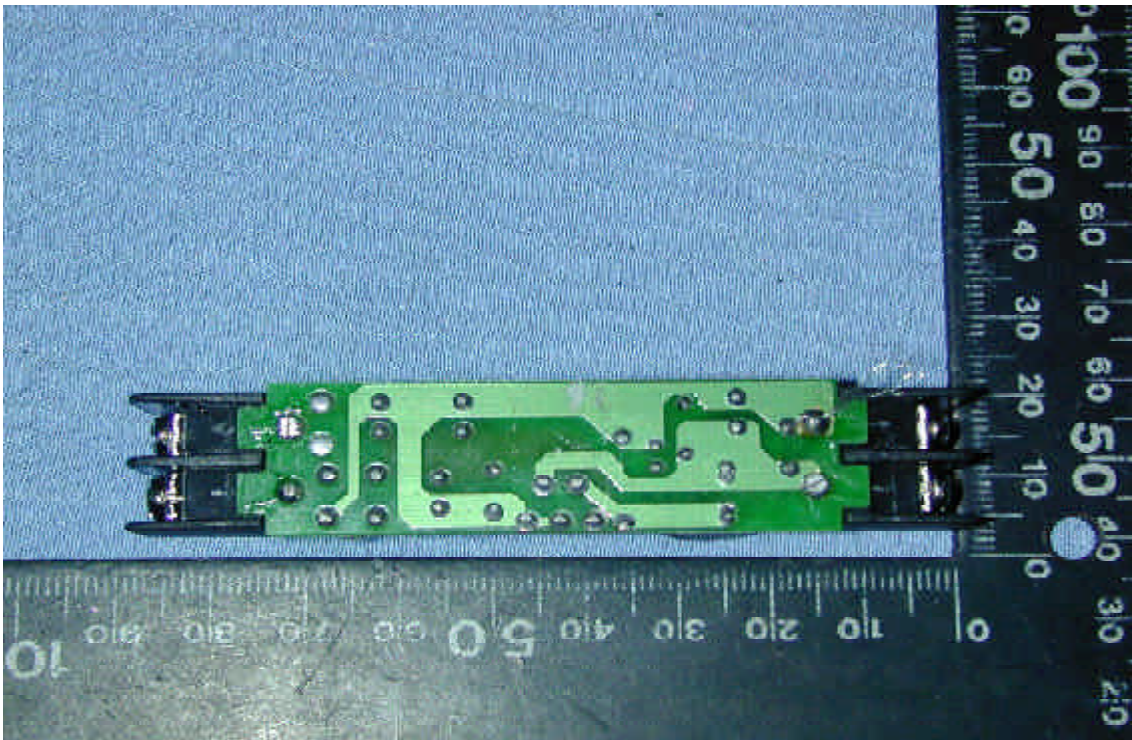
Inside View of EUT

PHOTO OF EUT

Model : PC1A



Component Side of Main Board - 1



Solder Side of Main Board - 1

United States Department of Commerce
National Institute of Standards and Technology

NVLAP®

ISO/IEC 17025:1999
ISO 9002:1994

Certificate of Accreditation



HOMETEK TECHNOLOGY INC.

TAIPEI SHIEN 236
TAIWAN

*is recognized by the National Voluntary Laboratory Accreditation Program
for satisfactory compliance with criteria set forth in NIST Handbook 150:2001,
all requirements of ISO/IEC 17025:1999, and relevant requirements of ISO 9002:1994.
Accreditation is awarded for specific services, listed on the Scope of Accreditation, for:*

ELECTROMAGNETIC COMPATIBILITY AND TELECOMMUNICATIONS

September 30, 2005

Effective through

A handwritten signature in black ink, appearing to read "Stephen P. Maki".

For the National Institute of Standards and Technology
NVLAP Lab Code: 200331-0

Scope of Accreditation



ELECTROMAGNETIC COMPATIBILITY AND TELECOMMUNICATIONS

NVLAP LAB CODE 200331-0

HOMETEK TECHNOLOGY INC.

P.O Box: 13-131, Pan-Chiao City
No. 67-9 Shir Men Rd., Tu Chen City
Taipei Shien 236
TAIWAN

Mr. Grant Huang

Phone: 886-2-22608375 Fax: 886-2-22748013

E-Mail: hometek@ms15.hinet.net

NVLAP Code Designation / Description

Emissions Test Methods:

- | | |
|-----------|--|
| 12/CIS22 | IEC/CISPR 22 (1997) & EN 55022 (1998) + A1(2000): Limits and methods of measurement of radio disturbance characteristics of information technology equipment |
| 12/CIS22a | IEC/CISPR 22 (1993) and EN 55022 (1994): Limits and methods of measurement of radio disturbance characteristics of information technology equipment, Amendment 1 (1995) and Amendment 2 (1996) |
| 12/CIS22b | CNS 13438 (1997): Limits and Methods of Measurement of Radio Interference Characteristics of Information Technology Equipment |
| 12/FCC15b | ANSI C63.4 (2001) with FCC Method 47 CFR Part 15, Subpart B: Unintentional Radiators |

September 30, 2005

Effective through

For the National Institute of Standards and Technology

National Institute
of Standards and Technology



National Voluntary
Laboratory Accreditation Program

ISO/IEC 17025:1999
ISO 9002:1994

Scope of Accreditation



Page: 2 of 2

**ELECTROMAGNETIC COMPATIBILITY
AND TELECOMMUNICATIONS**

NVLAP LAB CODE 200331-0

HOMETEK TECHNOLOGY INC.

NVLAP Code Designation / Description

12/T51 AS/NZS CISPR 22 (2002) and AS/NZS 3548 (1997): Electromagnetic Interference -
Limits and Methods of Measurement of Information Technology Equipment

September 30, 2005

Effective through

A handwritten signature in black ink, appearing to read 'William R. Miel'.

For the National Institute of Standards and Technology