



ADDRESS: No. 67-9, Shir Men Road, Tu Cheng City,
Taipei Hsien, Taiwan

PHONE : 886-2-22608375 FAX : 886-2-22748013

E - mail : hometek@ms15.hinet.net

CE TEST REPORT FOR

APPLICANT : Smart Home Engineering Corp.
ADDRESS : 10F., No. 493, Chung-Cheng Rd.,
Hsin-Tien City, Taipei 231, Taiwan, R. O. C.
Receipt Date : 01/12/2005 Final Test Date: 01/26/2005
EUT : Power Converter
MODEL NO. : PC500XXX, PCXXX

MEASUREMENT PROCEDURE USED

EN 61204-3 Class B GIVEN IN EUROPEAN COUNCIL DIRECTIVE 2004/108/EC

This test result of this report applies to above tested sample only.

This test report shall not be reproducing in part without written approval of HomeTek Technology Inc.

PREPARED BY :

HomeTek Technology Inc.

No. 67-9, Shir Men Road, Tu Cheng City,

Taipei Hsien. Taiwan

Report # : EB6K021

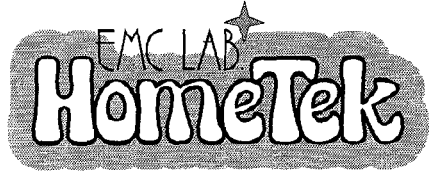

HomeTek Technology Inc.

ADDRESS: No. 67-9, Shir Men Road, Tu Cheng City,
Taipei Hsien, Taiwan, R. O. C.

PHONE : 886-2-22608375 FAX : 886-2-22748013

E - mail : hometek@ms15.hinet.net

CERTIFICATE OF COMPLIANCE

EUT : Power Converter

MODEL NO. : PC500XXX, PCXXX

Receipt Date : 01/12/2005 Final Test Date: 01/26/2005

REPORT # : EB6K021

APPLICANT : Smart Home Engineering Corp.

ADDRESS : 10F., No. 493, Chung-Cheng Rd.,
Hsin-Tien City, Taipei 231, Taiwan, R. O. C.

Measurement procedure used:

EN 61204-3 (2000) Class B,

CISPR 22 Class B, EN 61000-3-2 (2000), EN 61000-3-3 (1995) + A1 (2001),

IEC 61000-4-2 (2001), IEC 61000-4-3 (2002), IEC 61000-4-4 (2004), IEC 61000-4-5 (2001),

IEC 61000-4-6 (2003) + A1 (2004), IEC 61000-4-11 (2004)

We hereby show that:

The measurements shown in this test report were made in accordance with the procedures given in **EUROPEAN COUNCIL DIRECTIVE 2004/108/EC**, and the energy emitted by the equipment was found to be within the limits applicable. This product, which has been issued the test report listed as above in HomeTek Technology Inc., is based on single evaluation of one sample and confirmed to comply with the requirements of the above-mentioned EMC standard.

This test report is a duplicate of original one (report No. EB4A028, issued on 2005, 02, 02),

applicant and model No. is modified.

APPROVED BY :

ALAIN LIN / Assistant Manage



DESCRIPTION OF UPGRADE OF TEST STANDARDS

Applicant: Smart Home Engineering Corp.

Product Name: Power Converter

Model Number: PC500XXX, PCXXX

The test standard of this report (No. EB6K021) is updated from original one (No. EB4A028) with the procedures given in **EUROPEAN COUNCIL DIRECTIVE 2004/108/EC: EN 61204-3 (2000) Class B: CISPR 22 Class B / EN 61000-3-2 (2000) / EN 61000-3-3 (1995) + A1 (2001), IEC 61000-4-2 (2001), IEC 61000-4-3 (2002), IEC 61000-4-4 (2004), IEC 61000-4-5 (2001), IEC 61000-4-6 (2003) + A1 (2004), IEC 61000-4-11 (2004)**. According to EUT's specification and operation manual, the test procedures of new version of standards are applied to EUT. Thus, we HomeTek issue a new certificate with new version of test standard.

HomeTek Inc.

December, 07, 2007

ALAIN LIN / Assistant Manager

TEST REPORT CERTIFICATION**EMC of electrical appliances**

Report reference No. : EB6K021
Date of issue : DEC., 07, 2007
Applicant : Smart Home Engineering Corp.
Address : 10F., No. 493, Chung-Cheng Rd.,
Hsin-Tien City, Taipei 231, Taiwan, R. O. C.
Manufacturer : Smart Home Engineering Corp.
Type of test object : Power Converter
Model/type reference : PC500XXX, PCXXX
Rated Voltage : N/A
EUT Voltage : N/A
Test Result : Complied
Testing laboratory : HomeTek Technology Inc.
Address : No. 67-9, Shir Men Road, Tu Cheng City, Taipei Hsien,
Taiwan, R. O. C.
TEL / FAX : +886-2-22608375 / +886-2-22748013
E-mail : hometek@ms15.hinet.net
Standard : EN 61204-3 (2000) Class B:
CISPR 22 Class B, EN 61000-3-2 (2000),
EN 61000-3-3 (1995) + A1 (2001), IEC 61000-4-2 (2001),
IEC 61000-4-3 (2002), IEC 61000-4-4 (2004),
IEC 61000-4-5 (2001), IEC 61000-4-6 (2003) + A1 (2004),
IEC 61000-4-11 (2004)

Tested by (+ signature) :

Jason Lin / Engineer



Approved by (+ signature) :

Alain Lin / Assistant Manager





DESCRIPTION OF UPGRADE OF TEST STANDARDS 1

TEST REPORT CERTIFICATION..... 2

TABLE OF CONTENTS 3

GENERAL INFORMATION..... 6

MODIFICATION LIST 7

CONDUCTED POWER LINE TEST 8

 1 TEST PROCEDURE 8

 2 RESULT OF CONDUCTED EMISSION TEST 8

RADIATED EMISSION TEST 9

 1 TEST INSTRUMENTS & FACILITIES 9

 2 TEST PROCEDURE 10

 3 TEST SETUP..... 10

 4 CONFIGURATION OF THE EUT 11

 5 EUT OPERATING CONDITION 14

 6 LIMIT OF RADIATED EMISSION CLASS B 14

 7 RESULT OF RADIATED EMISSION TEST 14

 8 RADIATED EMISSION TEST DATA (PAGE 1) 15

 9 RADIATED EMISSION TEST DATA (PAGE 2) 16

HARMONICS TEST..... 17

 1 TEST PROCEDURE 17

 2 RESULT OF HARMONICS TEST 17

VOLTAGE FLUCTUATIONS TEST 18

 1 TEST PROCEDURE 18

 2 RESULT OF VOLTAGE FLUCTUATIONS TEST 18

ELECTROSTATIC DISCHARGE IMMUNITY TEST (ESD) 19

 1 TEST INSTRUMENTS & FACILITIES 19

 2 TEST PROCEDURE 19

 3 TEST SETUP..... 19

 4 CONFIGURATION OF THE EUT 20

 5 EUT OPERATION CONDITION 20

 6 TEST CONDITION 20

 7 PERFORMANCE CRITERIA 20

 8 TEST RESULT 21

RADIO FREQUENCY ELECTROMAGNETIC FIELD IMMUNITY TEST (RF)..... 22

 1 TEST INSTRUMENTS & FACILITIES 22

 2 TEST PROCEDURE 22

 3 TEST SETUP..... 23

 4 TEST LEVELS 24



5 CONFIGURATION OF THE EUT 24

6 OPERATION CONDITION OF EUT 24

7 TEST CONDITION..... 24

8 PERFORMANCE CRITERIA 25

9 TEST RESULT 25

ELECTRICAL FAST TRANSIENT/BURST IMMUNITY TEST (EFT)..... 26

1 TEST INSTRUMENTS & FACILITIES 26

2 TEST PROCEDURE 26

3 TEST SETUP..... 26

4 CONFIGURATION OF THE EUT 27

5 OPERATION CONDITION OF EUT 27

6 TEST CONDITION..... 27

7 PERFORMANCE CRITERIA 27

8 TEST RESULT 28

SURGE IMMUNITY TEST 29

1 TEST INSTRUMENTS & FACILITIES 29

2 TEST PROCEDURE 29

3 TEST SETUP..... 29

4 TEST LEVELS 30

5 CONFIGURATION OF THE EUT 30

6 EUT OPERATION CONDITION 30

7 CONDITIONS DURING TESTING 30

8 PERFORMANCE CRITERIA 31

9 TEST RESULT 31

IMMUNITY TEST TO CS CONDUCTED DISTURBANCE 32

1 TEST INSTRUMENTS & FACILITIES 32

2 TEST PROCEDURE 32

3 TEST SETUP..... 33

4 TEST LEVELS 34

5 CONFIGURATION OF THE EUT 34

6 EUT OPERATION CONDITION 34

7 CONDITIONS DURING TESTING 34

8 PERFORMANCE CRITERIA 35

9 TEST RESULT 35

POWER FREQUENCY MAGNETIC FIELD IMMUNITY TEST 36

1 TEST INSTRUMENTS & FACILITIES 36

2 TEST STANDARD 36

3 TEST SETUP..... 36

4 TEST LEVELS 37



5 CONFIGURATION OF THE EUT 37

6 OPERATION CONDITION OF EUT 37

7 CONDITIONS DURING TESTING 37

8 PERFORMANCE CRITERIA 37

9 TEST RESULTS 38

VOLTAGE DIPS, SHORT INTERRUPTIONS IMMUNITY TEST 39

1 TEST PROCEDURE 39

2 RESULT OF VOLTAGE DIPS, SHORT INTERRUPTIONS IMMUNITY TEST 39

APPENDIX A

PHOTOS OF TEST CONFIGURATION

APPENDIX B

PHOTOS OF EUT

GENERAL INFORMATION

- 1 APPLICANT : Smart Home Engineering Corp.
- 2 ADDRESS : 10F., No. 493, Chung-Cheng Rd.,
Hsin-Tien City, Taipei 231, Taiwan, R. O. C.
- 3 MANUFACTURER : Smart Home Engineering Corp.
- 4 ADDRESS : 10F., No. 493, Chung-Cheng Rd.,
Hsin-Tien City, Taipei 231, Taiwan, R. O. C.
- 5 DESCRIPTION OF EUT :
- EUT : Power Converter
- Model : PC500XXX, PCXXX
- Serial # : N/A

5.1 The difference between series of models PC500XXX and PCXXX is shown as below:

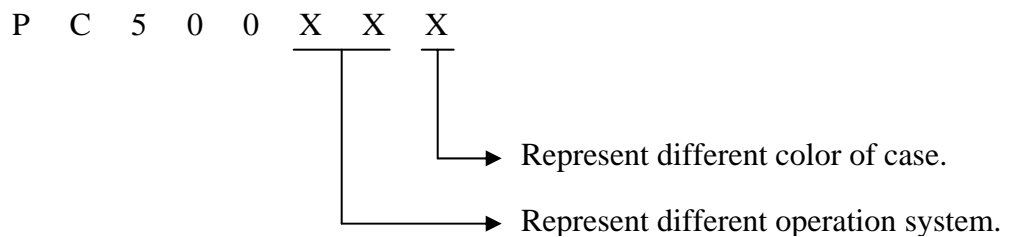

MODIFICATION LIST

THE FOLLOWING ACCESSORIES WERE ADDED TO THE EUT DURING TESTING :

NO MODIFICATION BY HOMETEK TECHNOLOGY INC.

CONDUCTED POWER LINE TEST

1 TEST PROCEDURE

According to **EN 61204-3**.

2 RESULT OF CONDUCTED EMISSION TEST

N/A (Conducted Power Line Test is not applicable to this EUT (Model : PC500)).

RADIATED EMISSION TEST

1 TEST INSTRUMENTS & FACILITIES

The following test Instruments was used during the radiated emission test :

Item	Instruments /facilities	Specification	Manufacturer	Model # / S/N#	Date of Cal.
1	OPEN AREA TEST SITE	<input checked="" type="checkbox"/> OATS 3			JUL/2004
2	EMI TEST RECEIVER	30MHz ~ 1GHz	ROHDE & SCHWARZ	ESVS10 845165/017	SEP/2004
3	RF SPECTRUM ANALYZER	N/A	HEWLETT PACKARD	8591E 3710A06158	MAY/2004
4	PRE-AMPLIFIER	9KHz ~ 3000MHz	ADVANTEST	BB525C 90081001	SEP/2004
5	ANTENNA (BI-LOG)	25MHz ~ 2GHz	SCHAFFNER	CBL6112B S/N : 2614	MAY/2004
6	Attenuation	50Ω/6dB	JYE BAO	FAT-N (M-F) 001	JUL/2004
7	Cable	10m	SUHNER	RG214/U OS3-003	DEC/2004
8	Cable	14m	BELDEN	9913 OS3-001	DEC/2004
9	EMI 32 (software)	N/A	AUDIX	19991013-0923	N/A

Note : Items 1 ~ 8 were calibrated within period of 1 year.

2 TEST PROCEDURE

- 2.1 The EUT was test according to **CISPR 22 Class B**.
- 2.2 The radiated test was performed at HomeTek Lab's Open Site III.
- 2.3 The frequency range from 30 MHz to 1 GHz, the measurement were made at 10 meters, with a BI-log antenna.

3 TEST SETUP

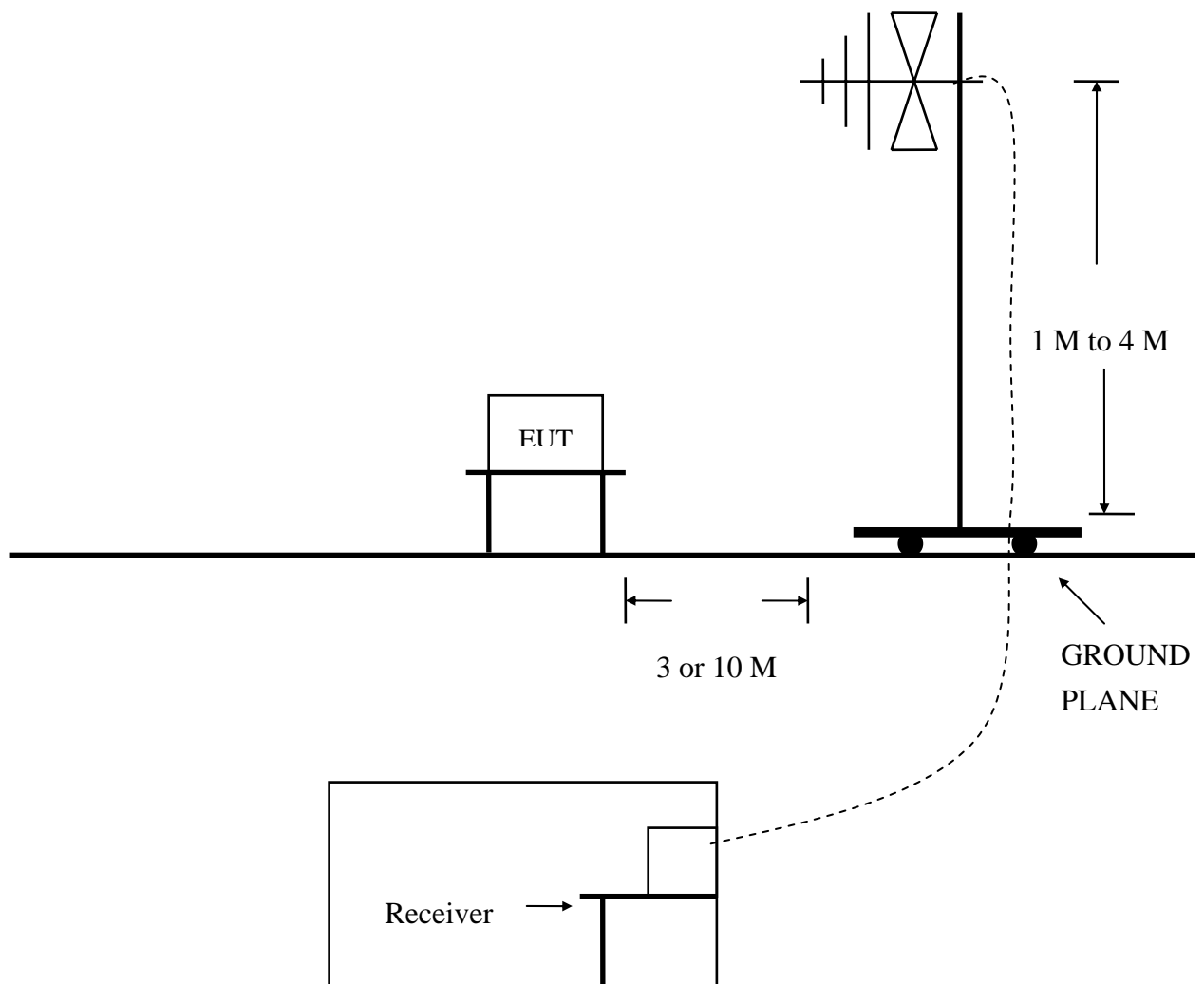

(Details for setup configuration, please refer to appendix A.)

4 CONFIGURATION OF THE EUT

The EUT was configured according to **EN 61204-3**. All I/O ports were connected to the appropriate peripherals. All peripherals and cables are listed below (including internal devices):

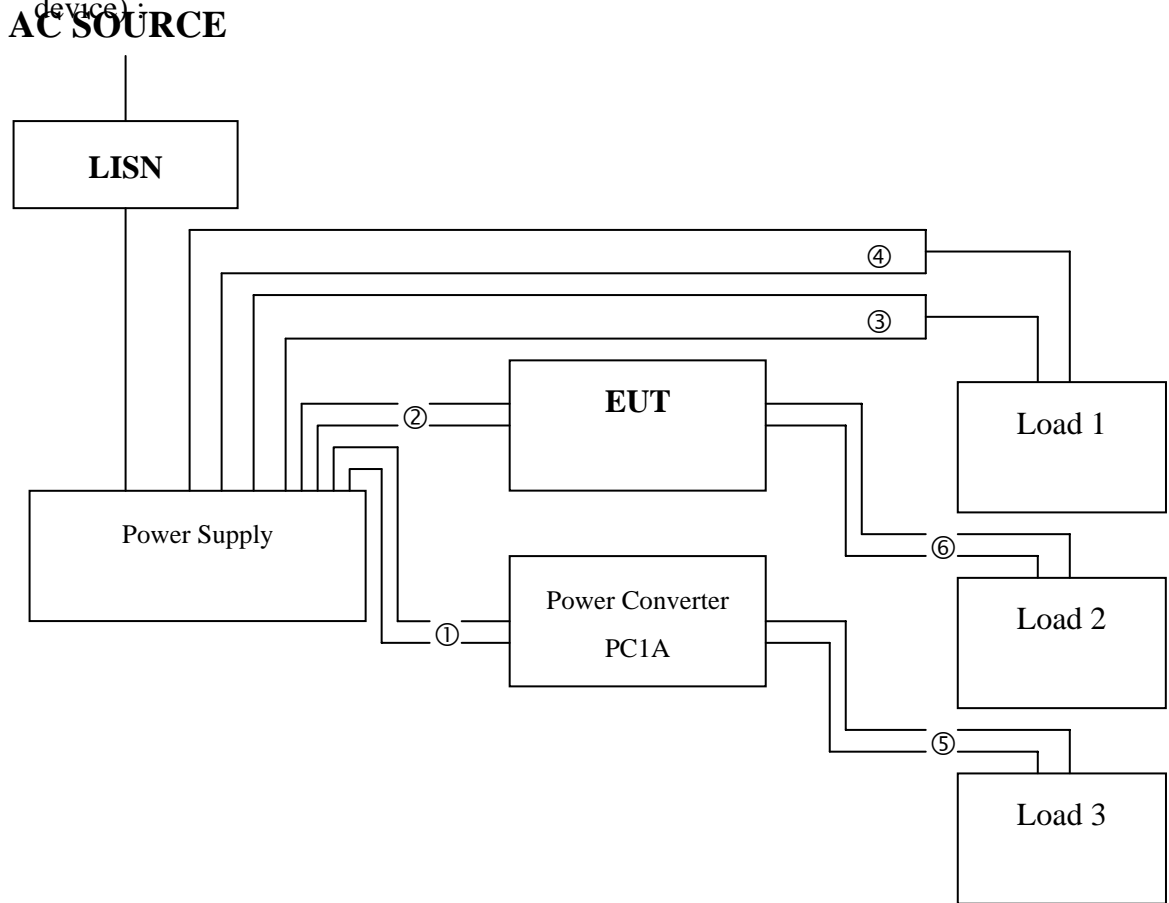

- ① DC,+, - Power Cable Output (DC 24V, To PC1A)
- ② DC,+, - Power Cable Output (DC 24V)
- ③ DC,+ Power Cable Output (DC 24V) x 6
- ④ DC,- Power Cable Output (DC 24V) x 6
- ⑤ DC,+, - Power Cable Output (DC 12V, To Load)
- ⑥ DC,+, - Power Cable Output (DC 12V, To Load)

Figure 1



4.1 EUT

EUT Type : Proto Type Engineer Type Mass Production
Condition when received : Good Damage : _____
Device : Power Converter
Applicant : Smart Home Engineering Corp.
Manufacturer : Smart Home Engineering Corp.
Model Number : PC500XXX, PCXXX
Serial Number : N/A
FCC ID : N/A
Data Cable : N/A
Power Cord (DC 24V) : Un-Shielded, 1 m, 2 pin
Power Cord (DC 12V) : Un-Shielded, 0.2 m, 2 pin
Power Supply Type : From Power Supply

4.2 PERIPHERALS

Power Supply

Manufacturer : SMART CABLING & TRANSMISSION CORP.
Model Number : PW408
Serial Number : N/A
FCC ID : N/A
Data Cable : N/A
Power Cord 1 : Un-Shielded, 1.8 m
Power Cord 2 : Un-Shielded, 1 m



Load 1

Manufacturer : HomeTek
Specification : DC 24V / 24R / 60W
Power Cord : Un-Shielded, 0.2 m

Power Converter

Manufacturer : SMART CABLING & TRANSMISSION CORP.
Model Number : PC1A
Serial Number : N/A
FCC ID : N/A
Data Cable : N/A
Power Cord : Un-Shielded, 1 m

Load 2 from PC1A (DC 24V Mode)

Manufacturer : HomeTek
Specification : DC 24V / 12R / 60W
Power Cord : Un-Shielded, 1 m

Load 3 from Power Supply PW408 (DC 24V Mode)

Manufacturer : HomeTek
Specification : DC 24V / 9.6R / 60W
Power Cord : Un-Shielded, 1 m

4.3 REMARK : N/A

5 EUT OPERATING CONDITION

- 5.1 The operation frequency of the EUT is 35 KHz.
- 5.2 Configure the EUT according to the **EN 61204-3**.
- 5.3 Connect AC 230V power to input port of Support Unit1(Power Supply PW408).
- 5.4 DC24V output port of Support Unit1(Power Supply PW408) Connect to input port of Support Unit2(Power Converter PC1A) and input port of EUT and dummy load(9.6R/60W Resistor)
- 5.5 DC12V output port of Support Unit2(Power Converter PC1A) connect to dummy load(12R/60W Resistor)
- 5.6 DC12V output port of EUT connect to dummy load(24R/60W Resistor)
- 5.7 Monitor the status of output port of EUT during the test (For EMS Testing)
- 5.8 **The photos of conducted test configuration, please refer to appendix A.**

6 LIMIT OF RADIATED EMISSION CLASS B

Frequency (MHz)	Measurement Distance	Limit (dBuV/m)
30 - 230	10 (M)	30
230 - 1000	10 (M)	37

7 RESULT OF RADIATED EMISSION TEST

- 7.1 The frequency range from 30 MHz to 1 GHz was investigated.
- 7.2 All readings below or equal 1 GHz are quasi-peak or peak values with resolution bandwidth of 120 KHz.
- 7.3 The measurements were made at 10 meters of HomeTek Lab's open site 3.
- 7.4 Temperature : 33 °C, Humidity : 55 % RH.
- 7.5 Deviation form the test standards and rules : None.
- 7.6 The radiated emission result were gained by the following method :
 Level = Reading Level + Probe Factor (Antenna Factor) + Cable Loss – Preamp Factor
 Over Limit = Level – Limit Line
- 7.7 Result : **PASSED**

8 RADIATED EMISSION TEST DATA (PAGE 1)



HomeTek Technology Inc.

No 67-9, Shi-Men Rd., Tu-Chen City,
 Taipei County, Taiwan R.O.C.
 Tel: 02-22608375
 Fax: 02-22748013

Data#: 3 File#: 6K021.emi

Date: 2005-01-18 Time: 16:23:23

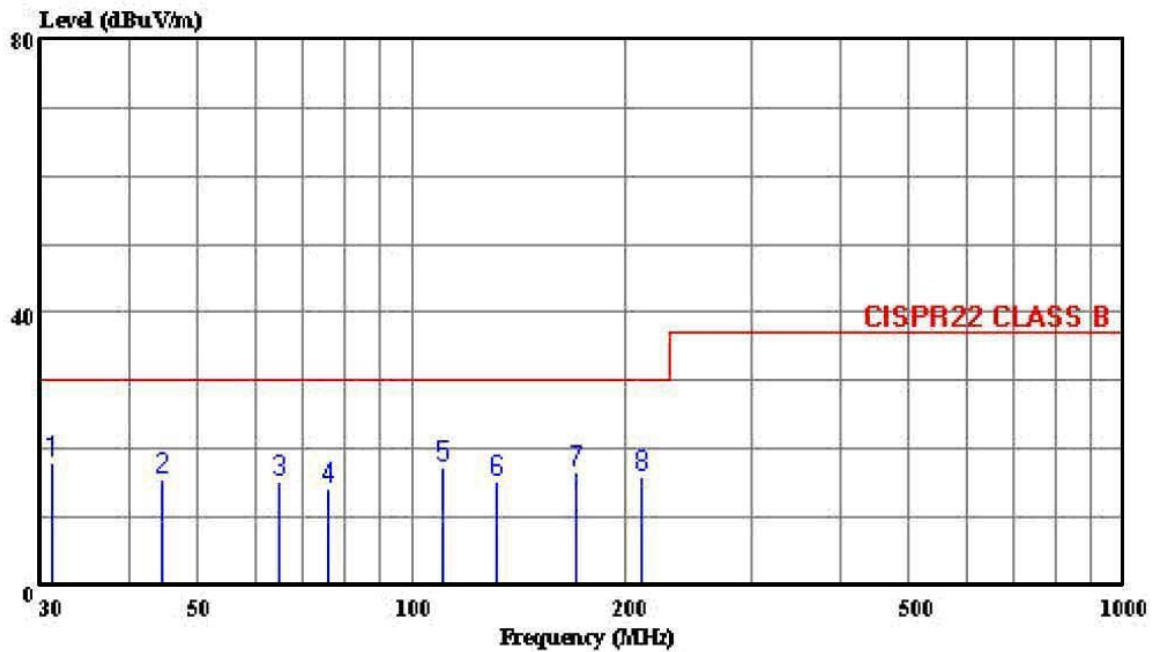

Trace:

Ref Trace:

Condition: CISPR22 CLASS B 10m CHASE 2614 052604 HORIZONTAL
 out : Power Converter (PC500-5V)
 power: FROM Power Supply (230V/50Hz)
 memo :

Page: 1

	Freq	Level	Limit	Over	ReadAntenna	Cable	Preamp	Remark
	MHz	dBuV/m	dBuV/m	dB	dBuV	dB/m	dB	dB
1	31.247	18.08	30.00	-11.92	30.25	16.94	0.78	29.89 Peak
2	44.521	15.42	30.00	-14.58	33.61	10.80	0.90	29.89 Peak
3	65.135	15.18	30.00	-14.82	38.11	5.64	1.06	29.62 Peak
4	76.405	14.35	30.00	-15.65	36.16	6.48	1.14	29.43 Peak
5	110.517	17.43	30.00	-12.57	33.64	11.51	1.38	29.10 Peak
6	131.051	15.30	30.00	-14.70	31.71	11.32	1.49	29.22 Peak
7	170.034	16.58	30.00	-13.42	35.71	8.60	1.72	29.45 Peak
8	210.574	15.99	30.00	-14.01	35.15	8.50	1.96	29.61 Peak

9 RADIATED EMISSION TEST DATA (PAGE 2)



HomeTek Technology Inc.

No 67-9, Shi-Men Rd., Tu-Chen City,
 Taipei County, Taiwan R.O.C.
 Tel: 02-22608375
 Fax: 02-22748013

Data#: 4 File#: 6K021.emi

Date: 2005-01-18 Time: 16:47:15

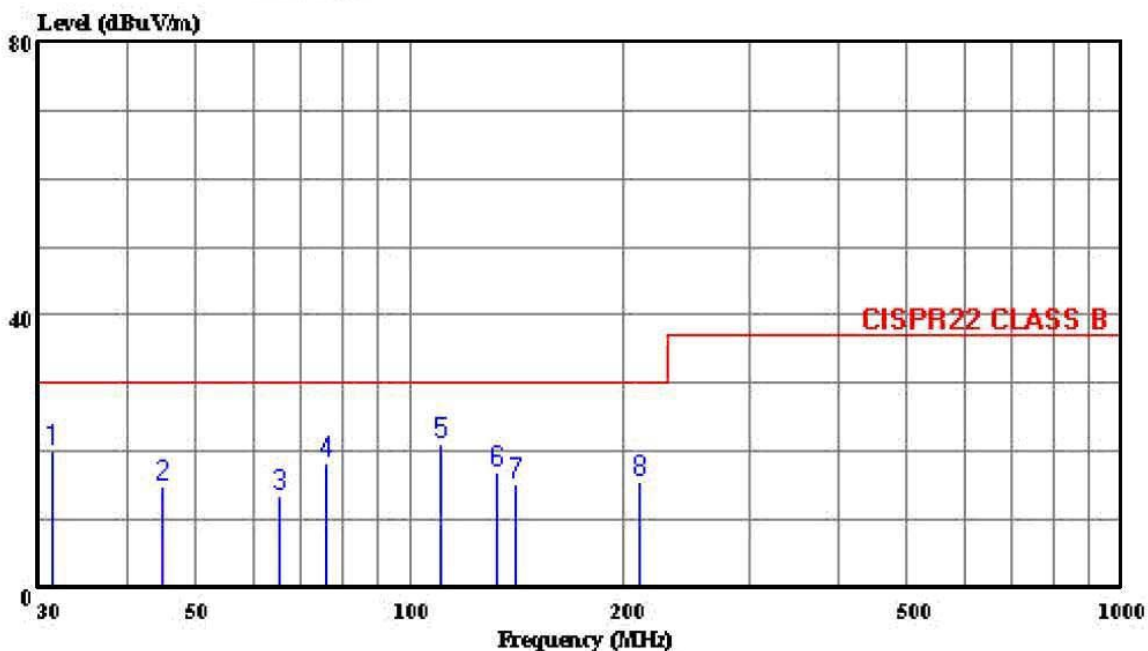

Trace:

Ref Trace:

Condition: CISPR22 CLASS B 10m CHASE 2614 052604 VERTICAL
 eut : Power Converter (PC500-5V)
 power: FROM Power Supply (230V/50Hz)
 memo :

Page: 1

	Limit	Over	ReadAntenna	Cable	Preamp				
Freq	Level	Line	Level	Loss	Factor	Remark			
MHz	dBuV/m	dBuV/m	dB	dB	dB				
1	31.432	19.94	30.00	-10.06	32.14	16.91	0.78	29.89	Peak
2	44.715	14.93	30.00	-15.07	33.17	10.75	0.90	29.89	Peak
3	65.247	13.39	30.00	-16.61	36.31	5.63	1.06	29.62	Peak
4	76.030	18.27	30.00	-11.73	40.14	6.43	1.14	29.44	Peak
5	110.527	21.27	30.00	-8.73	37.48	11.51	1.38	29.10	Peak
6	132.448	17.10	30.00	-12.90	33.62	11.20	1.50	29.23	Peak
7	140.121	15.15	30.00	-14.85	32.37	10.50	1.55	29.28	Peak
8	210.440	15.67	30.00	-14.33	34.82	8.50	1.96	29.61	Peak

HARMONICS TEST

1 TEST PROCEDURE

According to **EN 61000-3-2 (2000) Class A**

2 RESULT OF HARMONICS TEST

N/A (This standard is not applicable to this EUT (Model : PC500-5V)).

VOLTAGE FLUCTUATIONS TEST

1 TEST PROCEDURE

According to **EN 61000-3-3 (1995) + A1 (2001)**.

2 RESULT OF VOLTAGE FLUCTUATIONS TEST

N/A (This standard is not applicable to this EUT (Model : PC500-5V)).

ELECTROSTATIC DISCHARGE IMMUNITY TEST (ESD)

1 TEST INSTRUMENTS & FACILITIES

Instruments/ Facilities	Manufacturer	Model # Serial #	Data Of Cal.
ESD TESTER	NOISEKEN	ESS-100L (A)	OCT/2004
VCP	HOMETEK	--	--

2 TEST PROCEDURE

According to **IEC 61000-4-2 (2001)**

According to **EN 61204-3 (2000)**

3 TEST SETUP

TABLE SIZE

160L X 80W X 80H cm

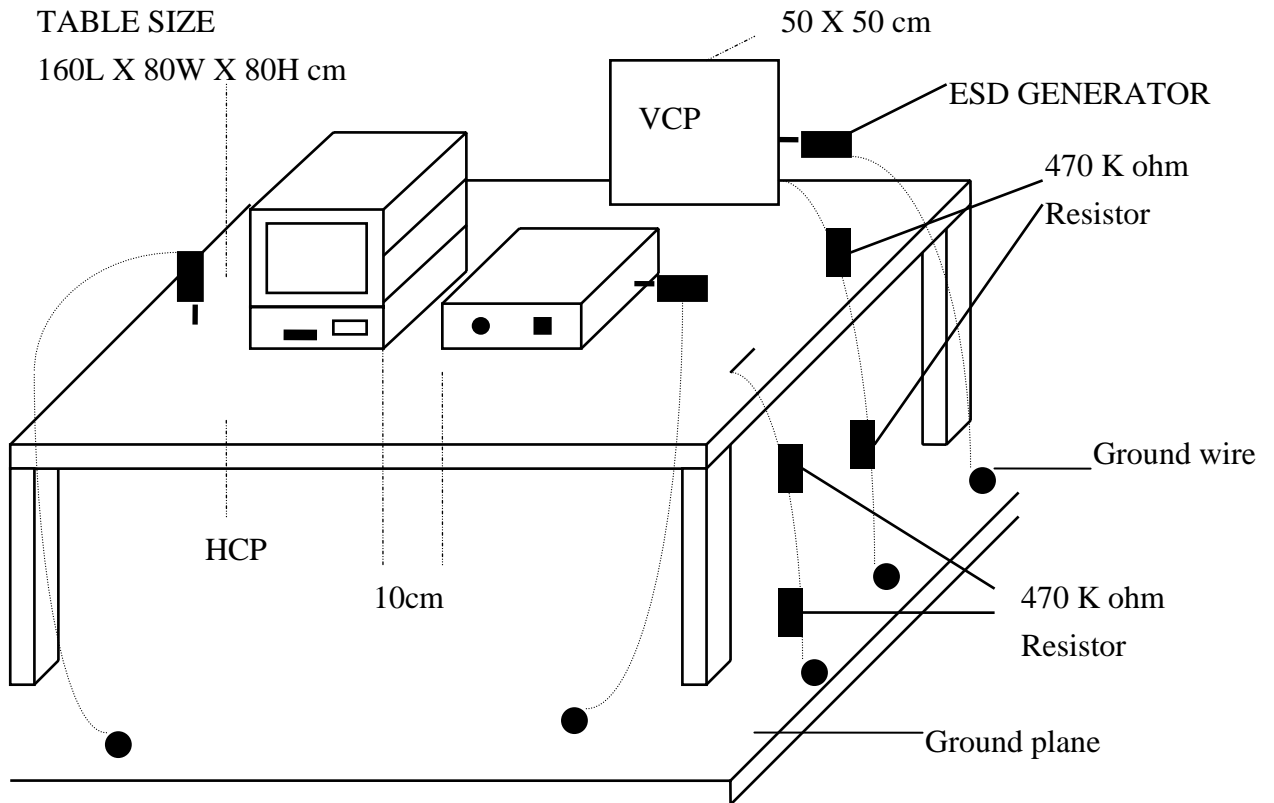

(Details for setup configuration, please refer to appendix A.)

4 CONFIGURATION OF THE EUT

Same as “Conducted Power Line test”, section 4

5 EUT OPERATION CONDITION

Same as “Conducted Power Line test”, section 5

6 TEST CONDITION

6.1 Test Level :

(A) ± 2 , ± 4 , ± 8 KV for air discharge.

(B) ± 2 , ± 4 KV for contact discharge.

6.2 Number of test : 10 Discharges / Test point / Polarity / Level

6.3 Time between test : 1 sec.

6.4 Temperature : 22 °C

6.5 Humidity : 56 % RH.

7 PERFORMANCE CRITERIA

A. Normal performance within the specification.

B. Temporary degradation or loss function or performance which is self-recoverable.

C. Temporary degradation or loss function or performance which requires operator intervention system reset.

D. Degradation or loss function which is not recoverable due to damage of EUT or software, or loss of data.

8 TEST RESULT

Test Point	Air Discharge	Contact Discharge	Performance Criteria	Result
HCP	---	$\pm 2, \pm 4\text{KV}$	A	PASSED
VCP	---	$\pm 2, \pm 4\text{KV}$	A	PASSED
CASE	$\pm 2, \pm 4, \pm 8\text{KV}$	$\pm 2, \pm 4\text{KV}$	A	PASSED

9 Photos of test configuration please refer to appendix A.

RADIO FREQUENCY ELECTROMAGNETIC FIELD IMMUNITY TEST (RS)

1 TEST INSTRUMENTS & FACILITIES

Item	Instruments Facilities	Manufacturer	Model # Serial #	Data Of Cal.
1	SIGNAL GENERATOR	ROHDE & SCHWARZ	SMY02 845181/025	MAR/2004
2	AMPLIFIER	AMPLIFIER RESEARCH	100W1000M1A	N/A
3	FIELD SENSOR	AMPLIFIER RESEARCH	FP2000	AUG/2004
4	FIELD MONITOR	AMPLIFIER RESEARCH	FM2000	AUG/2004
5	RF VOLTMETER	BOONTON	9200C 361701AA	MAR/2004
6	RF PROBE	BOONTON	952001B 37082	MAR/2004
7	DIRECTION COUPLER	AMPLIFIER RESEARCH	DC6180 20521	N/A
8	ANTENNA	EMCO	3142B S/N: 1789	N/A
9	CONTROL PC	KB TECH	KB P586/133	--

Note : Items 3 ~ 4 were calibrated with two years and verified before testing.

2 TEST PROCEDURE

According to **IEC 61000-4-3 (2002)**

According to **EN 61204-3 (2000)**

3 TEST SETUP

FERRITE TILE

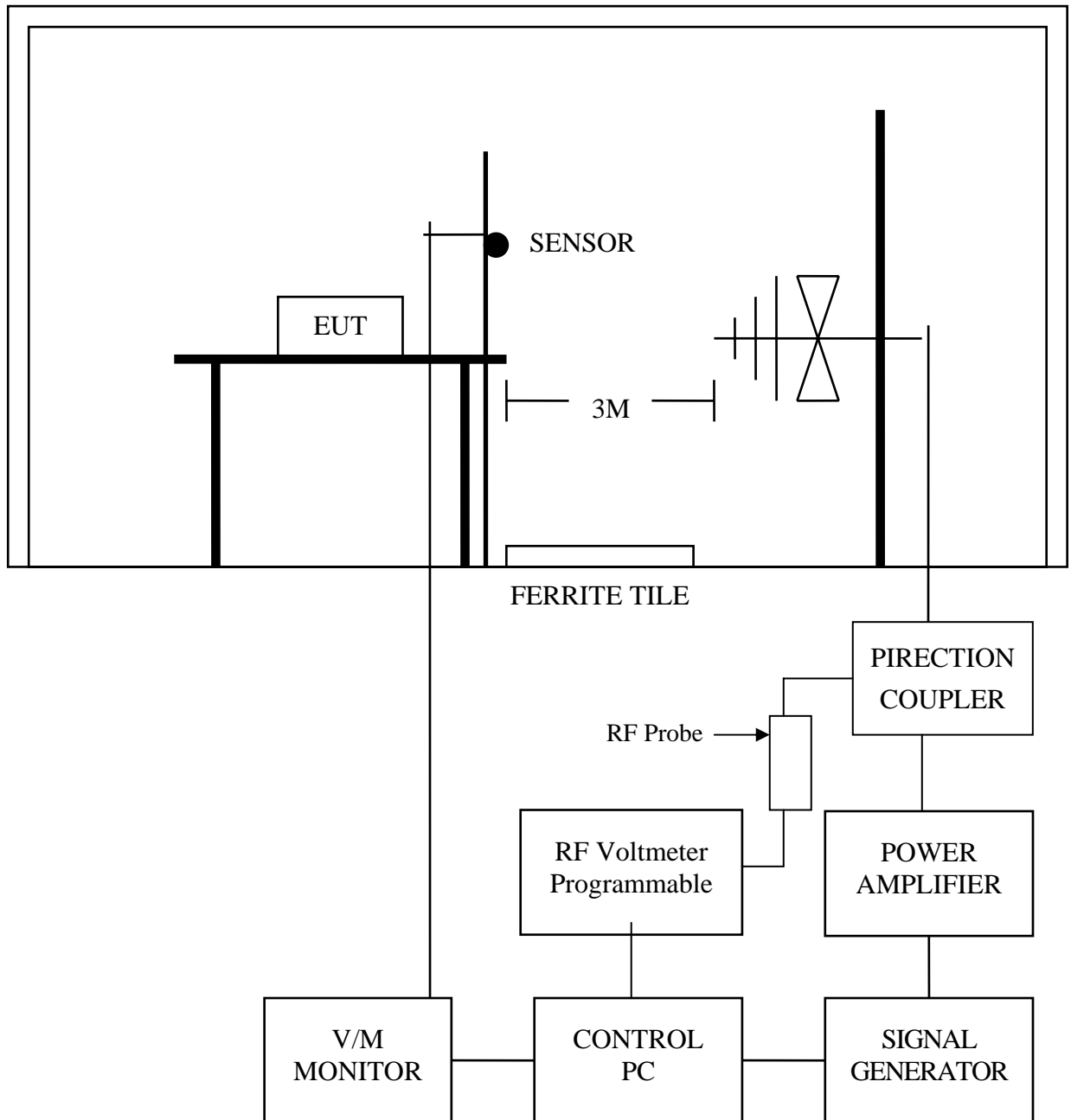

3.1 Chamber Size :

12M x 5M x 5M

(Details for setup configuration, please refer to appendix A.)

4 TEST LEVELS

Environmental Phenomenon	Test Item	Test Specification
Radio-frequency Electromagnetic Field Amplitude Modulated	Frequency Range	80MHz ~ 1000MHz (Frequency Range : <u>1.4</u> GHz ~ <u>2.0</u> GHz is not applicable for EN61204:2000)
	Field Strength	3V/m
	AM 1kHz	80%
Radio-frequency Electromagnetic Field Keyed Carrier	Frequency Rang	900 ± 5MHz
	Field Strength	3V/m
	Duty Cycle	50%
	Repetition Frequency	200Hz

5 CONFIGURATION OF THE EUT

Same as “Conducted Power Line test”, section 4

6 OPERATION CONDITION OF EUT

Same as “Conducted Power Line test”, section 5

7 TEST CONDITION

7.1 Frequency Step : 1 %, 3 sec. / each step size

7.2 Antenna Polarity : HORIZONTAL & VERTICAL

7.3 The four sides of EUT are tested
(FRONT, REAR, RIGHT, LEFT)

7.4 Temperature : 27 °C

7.5 Humidity : 60 % RH

8 PERFORMANCE CRITERIA

- A. Normal performance within the specification.
- B. Temporary degradation or loss function or performance which is self-recoverable.
- C. Temporary degradation or loss function or performance which requires operator intervention system reset.
- D. Degradation or loss function which is not recoverable due to damage of EUT or software, or loss of data.

9 TEST RESULT

ANT SIDE	HORIZONTAL	VERTICAL	RESULT
FRONT	A	A	PASSED
REAR	A	A	PASSED
RIGHT	A	A	PASSED
LEFT	A	A	PASSED

9 Photos of test configuration please refer to appendix A.

ELECTRICAL FAST TRANSIENT/BURST IMMUNITY TEST (EFT)

1 TEST INSTRUMENTS & FACILITIES

Instruments/ Facilities	Manufacturer	Model # Serial #	Data Of Cal.
BURST-TESTER	HAEFELY	PEFT/JUNIOR	FEB/2004
CONTROL PC	KB TECH	KB P586/133	--

2 TEST PROCEDURE

According to **IEC 61000-4-4 (2004)**

According to **EN 61204-3 (2000)**

3 TEST SETUP

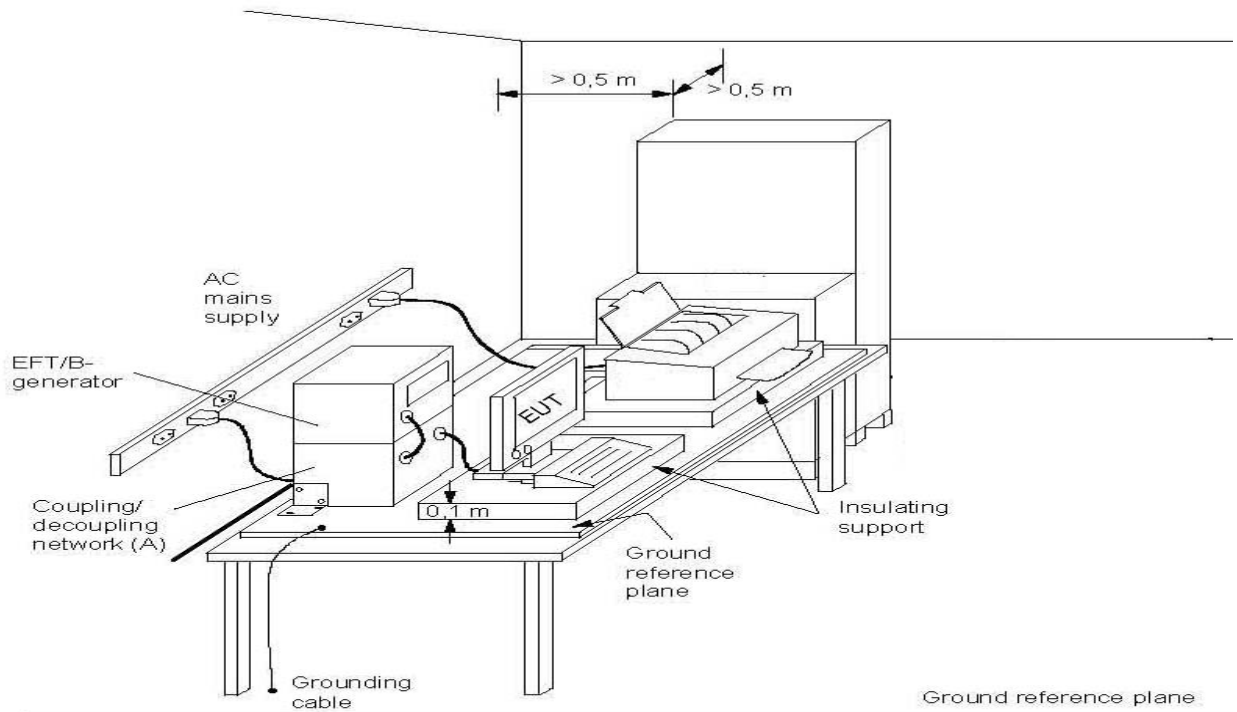

Note: length between clamp and the EUT to be tested (should be $0.5 \text{ m} \pm 0.05 \text{ m}$)

(A) location for supply line coupling

(B) location for signal line coupling

4 CONFIGURATION OF THE EUT

Same as “Conducted Power Line test”, section 4

5 OPERATION CONDITION OF EUT

Same as “Conducted Power Line test”, section 5

6 TEST CONDITION

6.1 Pulse Rise time & Duration : 5 nS / 50 nS

6.2 Pulse Repetition : 5 kHz

6.3 Polarity : POSITIVE / NEGATIVE

6.4 Test Voltage : $\pm 0.5\text{KV}$, $\pm 1\text{KV}$

6.5 Coupling of power line :
L, N, L+N

6.6 Temperature : 27 °C

6.7 Humidity : 60 % RH

7 PERFORMANCE CRITERIA

- A. Normal performance within the specification.
- B. Temporary degradation or loss function or performance which is self-recoverable.
- C. Temporary degradation or loss function or performance which requires operator intervention system reset.
- D. Degradation or loss function which is not recoverable due to damage of EUT or software, or loss of data.

8 TEST RESULT

TEST VOLTAGE	L	N	L+N
$\pm 0.5\text{KV}$	A	A	A
$\pm 1\text{KV}$	A	A	A

8.1 Model : PC500-5V

8.2 Final Result : PASSED

8.3 Remark :

9 Photos of test configuration please refer to appendix A.

SURGE IMMUNITY TEST

1 TEST INSTRUMENTS & FACILITIES

Instruments/ Facilities	Manufacturer	Model # Serial #	Data Of Cal.
SURGER-TESTER	HAEFELY	PSURGE 4010 583334-38	FEB/2004
CONTROL PC	KB TECH	KB P586/133	--

2 TEST PROCEDURE

According To **IEC 61000-4-5 (2001)**

According To **EN 61204-3 (2000)**

3 TEST SETUP

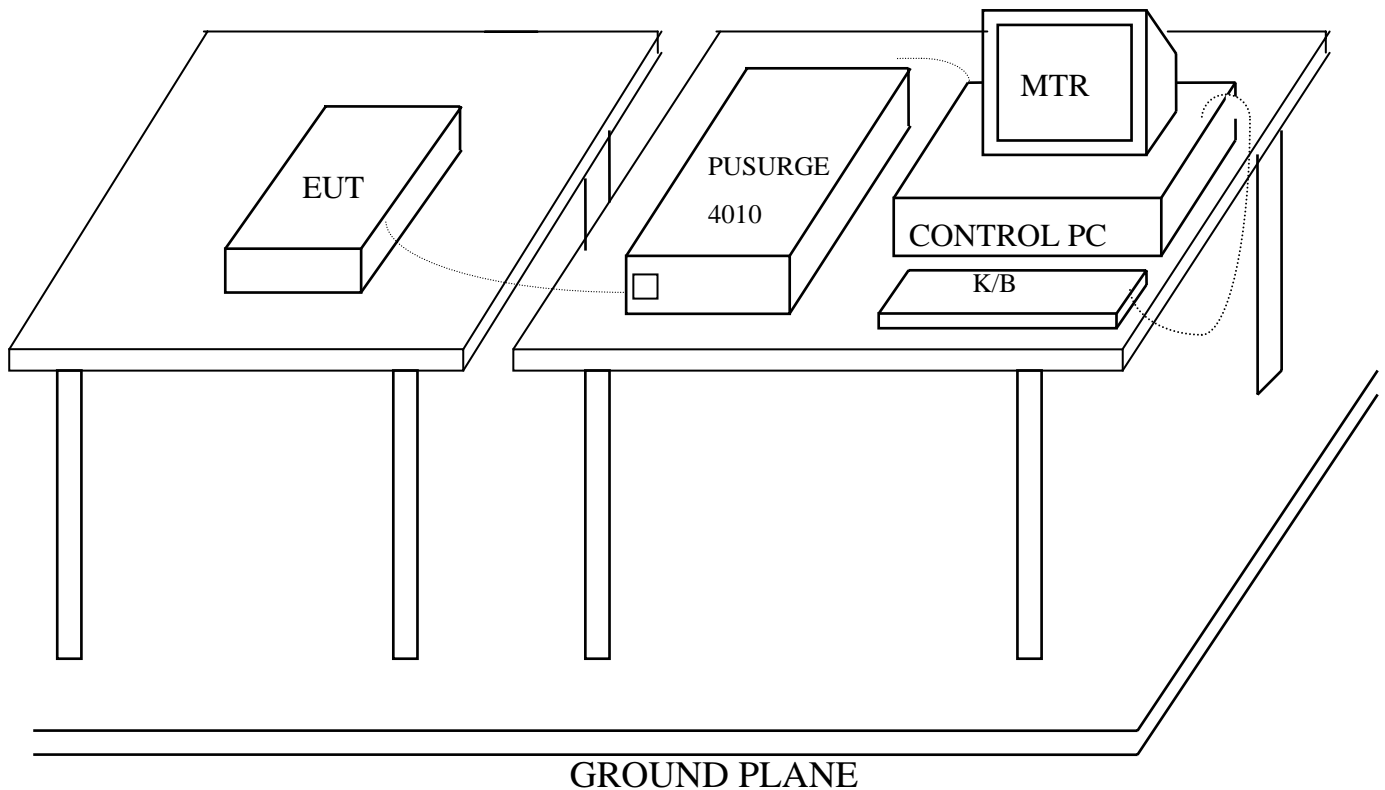

4 TEST LEVELS

- Input and Output AC Power Ports.
- DC Input and DC Output Power Ports.

Environmental Phenomena	Test Specification		Units	Performance Criteria
	AC	DC		
Surges	1.2 / 50 (8/20)		Tr /Th us	
Line to Line	±1	±0.5	KV (Charge Voltage)	B

5 CONFIGURATION OF THE EUT

Same as “Conducted Power Line test”, section 4

6 EUT OPERATION CONDITION

Same as “Conducted Power Line test”, section 5

7 CONDITIONS DURING TESTING

7.1 Coupling of power line :

(A) Line to Line ±1KV (AC) or ±0.5KV (DC)

7.2 Polarity : POSITIVE / NEGATIVE

7.3 Phase shifting in a range between 0° to 360°

7.4 Repetition rate at least 1 per min

7.5 Temperature : 27 °C (15°C ~ 35°C)

Humidity : 60 % RH.(10 % ~ 75%)

8 PERFORMANCE CRITERIA

- A. Normal performance within the specification limits.
- B. Temporary degradation or loss of function or performance which is self-recoverable.
- C. Temporary degradation or loss of function or performance which requires operator intervention or system reset.
- D. Degradation or loss of function which is not recoverable due to damage of equipment (components).

9 TEST RESULT

Environmental Phenomena	Test Specification	Units	Performance
Line to Line	±1	KV (Charge Voltage)	A

9.1 Model : PC500-5V

9.2 Final Result : PASSED

9.3 Remark :

10 Photos of test configuration please refer to appendix A.

IMMUNITY TEST TO CS CONDUCTED DISTURBANCE

1 TEST INSTRUMENTS & FACILITIES

Instruments/ Facilities	Manufacturer	Model # Serial #	Date Of Cal.
SIGNAL GENERATOR	ROHDE & SCHWARZ	SMY02 845181/025	MAR/2004
AMPLIFIER	AMPLIFIER RESEARCH	75A250 25680	N/A
RF VOLTMETER	BOONTON	9200C 361701AA	MAR/2004
RF PROBE	BOONTON	952001B 37082	MAR/2004
DIRECTION COUPLER	AMPLIFIER RESEARCH	DC2600 20508	N/A
COUPLING DECOUPLING NETWORK	FCC	FCC-801-M3-25A 9993	FEB/2004
CONTROL PC	KB TECH	KB P586/133	--

2 TEST PROCEDURE

According To **IEC 61000-4-6 (2003) + A1 (2004)**

According To **EN 61204-3 (2000)**

3 TEST SETUP

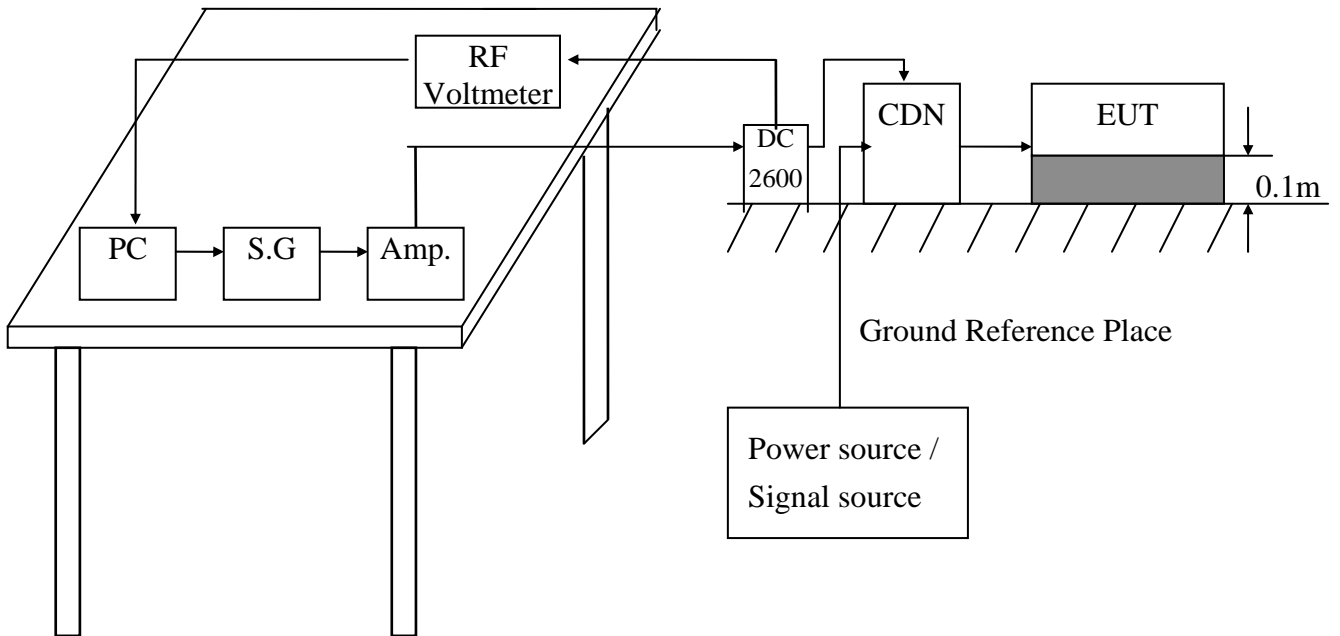

(Details for setup configuration, please refer to appendix A.)

4 TEST LEVELS

- Ports for signal lines and control lines.
- DC input and DC output power ports.
- Input and Output AC Power Ports.
- Functional earth Ports.

Environmental	Test Specification	Units	Performance
Radio-frequency	0.15 - 80	MHz	
Common mode	3	V	A
	80	% AM (1KHz)	

5 CONFIGURATION OF THE EUT

Same as “Conducted Power Line test”, section 4

6 EUT OPERATION CONDITION

Same as “Conducted Power Line test”, section 5

7 CONDITIONS DURING TESTING

7.1 The EUT tested type :

- Single unit
- Multiple unit

7.2 Dwell time : < 1%

7.3 Temperature : 27 °C (15°C ~ 35°C)

Humidity : 60 % RH.(10 % ~ 75%)

8 PERFORMANCE CRITERIA

- A. Normal performance within the specification limits.
- B. Temporary degradation or loss of function or performance which is self-recoverable.
- C. Temporary degradation or loss of function or performance which requires operator intervention or system reset.
- D. Degradation or loss of function which is not recoverable due to damage of equipment (components).

9 TEST RESULT

TEST Specification	Unit	Performance Criteria
0.15 - 80	MHz	A
3	V	
80	% AM (1KHz)	

9.1 Model : PC500-5V

9.2 Final Result : PASSED

9.3 Remark :

10 Photos of test configuration please refer to appendix A.

POWER FREQUENCY MAGNETIC FIELD IMMUNITY TEST

1 TEST INSTRUMENTS & FACILITIES

Instruments/ Facilities	Manufacturer	Model # Serial #	Data Of Cal.
LINE INTERFERENCE TESTER	HAEFELY	PLINE 1610 080166-10	MAR/2004
MAGNETIC FIELD TESTER	HAEFELY	MAG 100.1 080206-01	N/A
TRIAXIAL ELF MAGNETIC FIELD METER	F.W.BELL	4080 9645	JUN/2004
CONTROL PC	KB TECH	KB P586/133	--

2 TEST STANDARD

According to **IEC 61000-4-8 (2001)**

According to **EN 61204-3 (2000)**

3 TEST SETUP

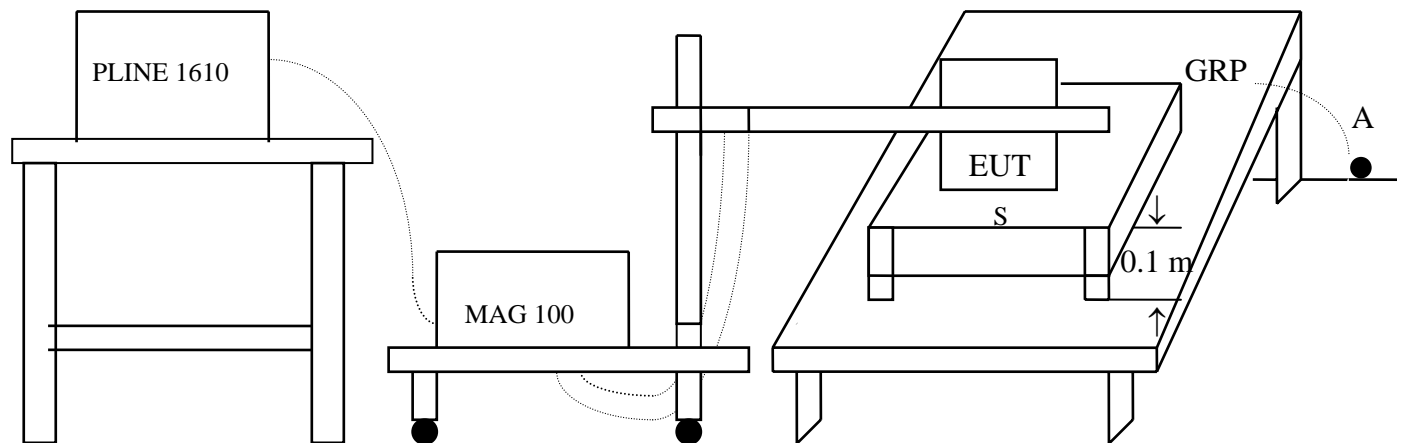

S: Insulating support

A: Safety earth

GRP: Ground plane

4 TEST LEVELS

Environmental Phenomena	Test Specification	Units	Performance Criteria
Power Frequency	50	HZ	
Magnetic Field	3	A/m	A

5 CONFIGURATION OF THE EUT

Same as “Radiated Emission Test”, section 4

6 OPERATION CONDITION OF EUT

Same as “Radiated Emission Test”, section 5

7 CONDITIONS DURING TESTING

7.1 Temperature : 21 °C (15°C ~ 35°C)

Humidity : 72 % RH.(25 % ~ 75%)

7.2 The induction coil shall be rotated by 90°

8 PERFORMANCE CRITERIA

- A. Normal performance within the specification limits.
- B. Temporary degradation or loss of function or performance which is self-recoverable.
- C. Temporary degradation or loss of function or performance which requires operator intervention or system reset.
- D. Degradation or loss of function which is not recoverable due to damage of equipment (components).

9 TEST RESULTS

Environmental Phenomena	Test Specification	Units	Performance Criteria
Magnetic Field	3	A/m	A

9.1 Model : PC500-5V

9.2 Final Results : PASSED

9.3 Remark :

VOLTAGE DIPS, SHORT INTERRUPTIONS IMMUNITY TEST

1 TEST PROCEDURE

According to **IEC 61000-4-11 (2004)**

According to **EN 61204-3 (2000)**

2 RESULT OF VOLTAGE DIPS, SHORT INTERRUPTIONS IMMUNITY TEST

N/A (This standard is not applicable to this EUT (Model : PC500-5V)).



HomeTek Technology Inc.

Appendix A

PHOTOS OF TEST CONFIGURATION

PHOTO OF RADIATED EMISSION TEST

Model : PC500-5V



Front View

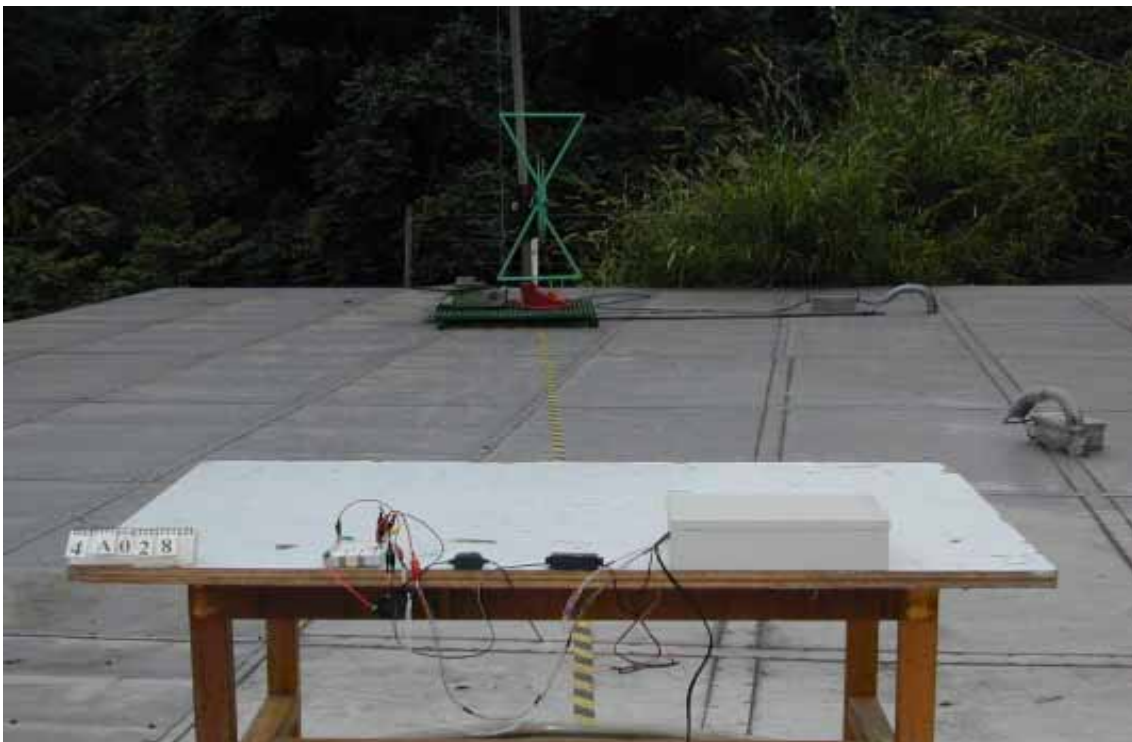

Rear View

PHOTO OF SURGE IMMUNITY TEST

Model : PC500-5V



PHOTO OF ELECTRICAL FAST TRANSIENT/BURST IMMUNITY TEST



PHOTO OF ELECTROSTATIC DISCHARGE IMMUNITY TEST (ESD)

Model : PC500-5V



Front View

**PHOTO OF RADIO FREQUENCY ELECTROMAGNETIC FILE
IMMUNITY TEST (RS)**

Model : PC500-5V



PHOTO OF CS CONDUCTED DISTURBANCE IMMUNITY TEST

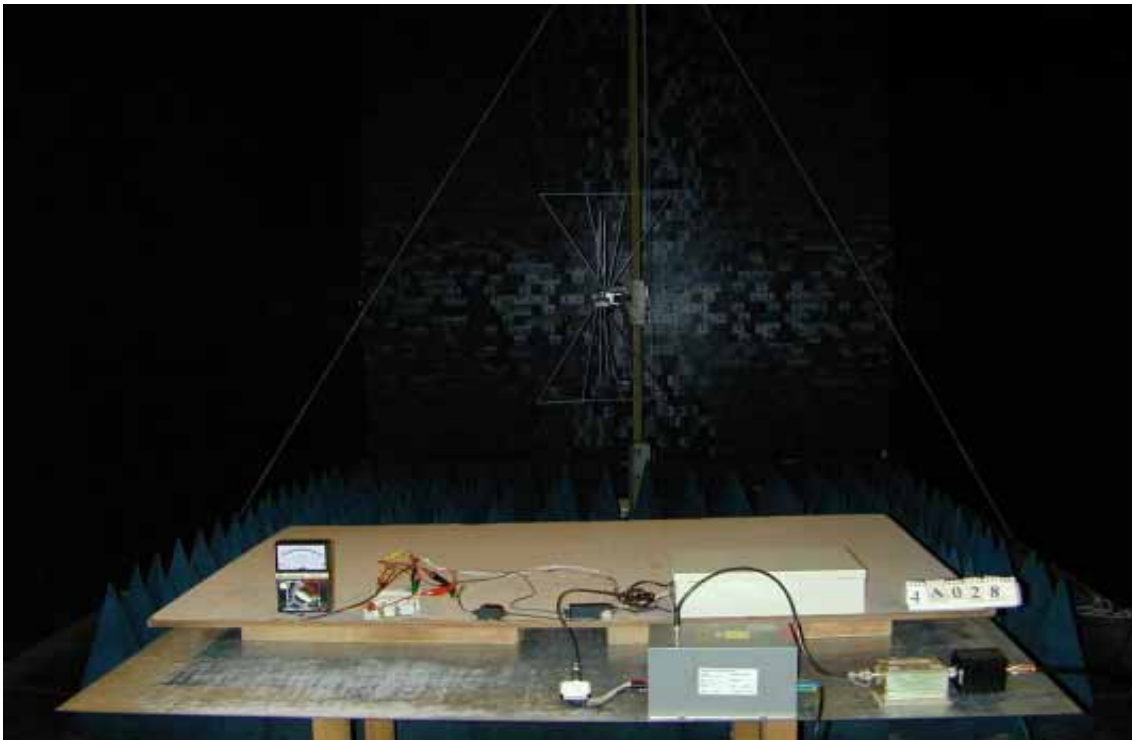



HomeTek Technology Inc.

Appendix B

PHOTOS OF EUT

PHOTO OF EUT

Model : PC500-5V

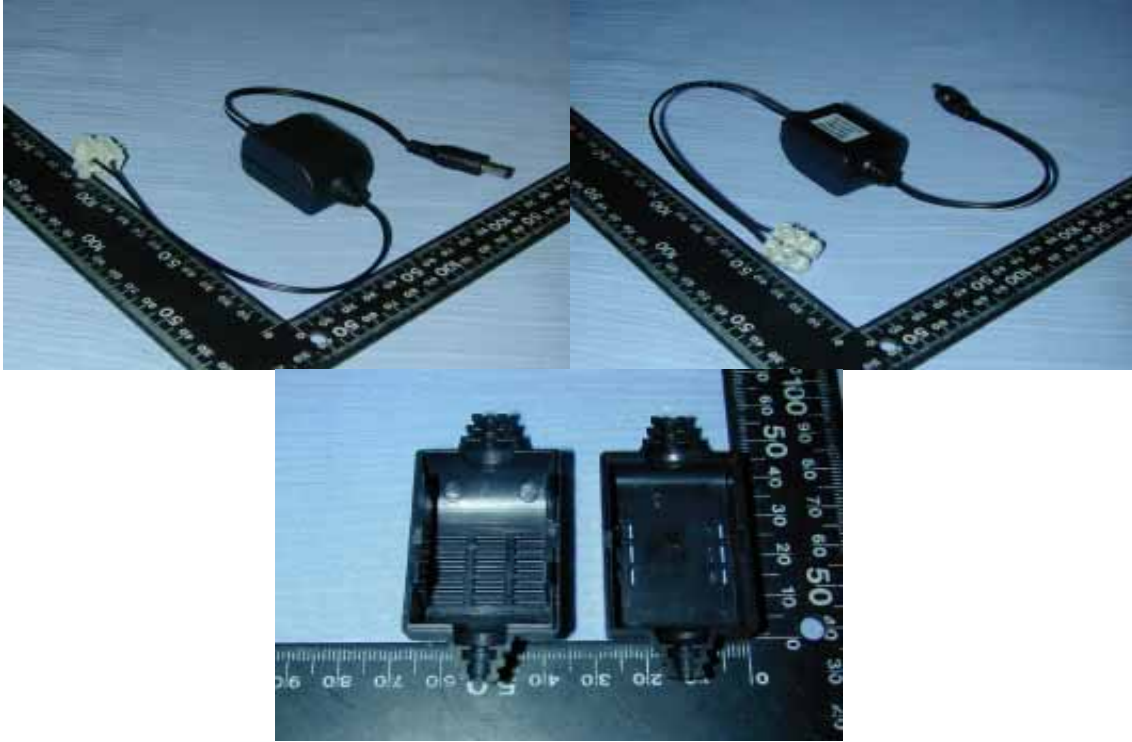

Full View of EUT



Inside View of EUT

PHOTO OF EUT

Model : PC500-5V

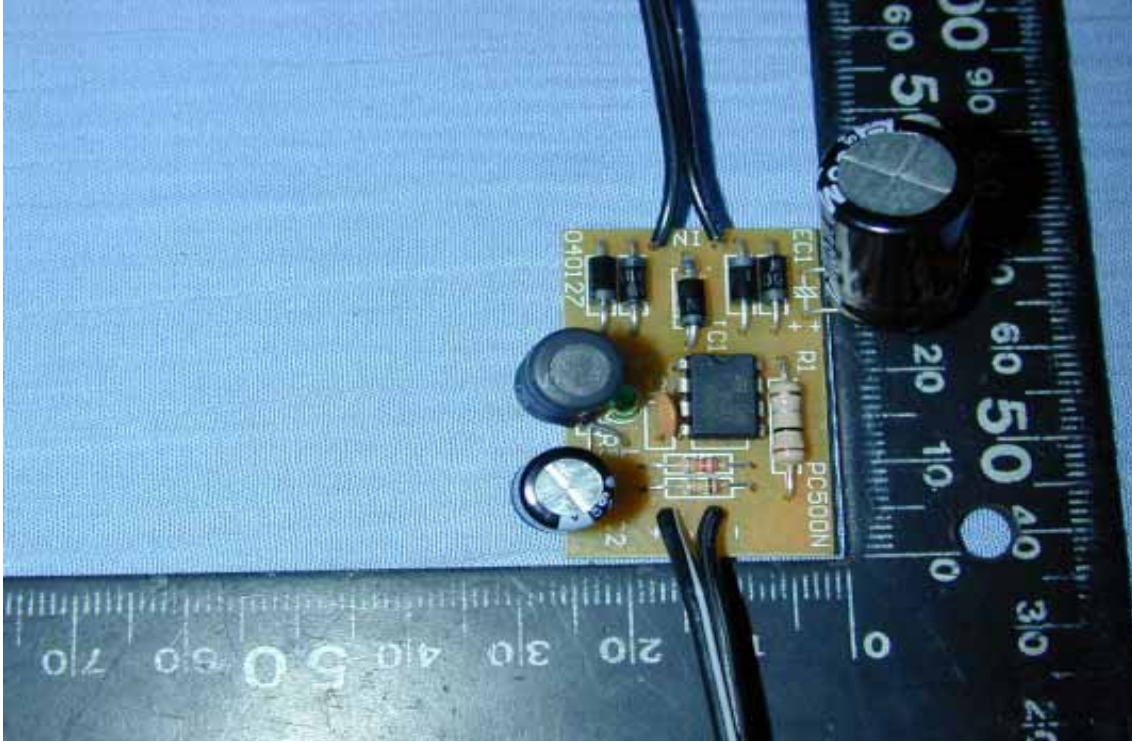

Component Side of Main Board

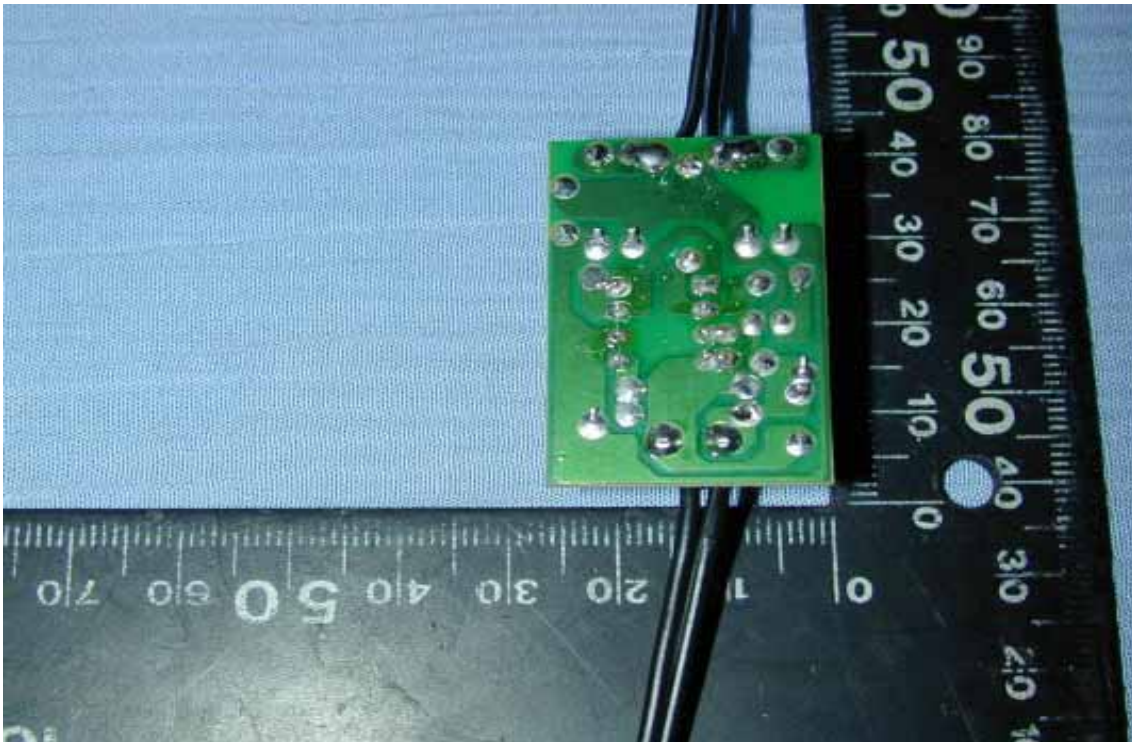

Solder Side of Main Board

Declaration of Conformity

We(Manufacturer/Importer)

(company name)

(address)

declares under our sole responsibility that the product

Product name : Power Converter

Model No. : PC500XXX, PCXXX

to which this declaration relates is in conformity with the following standard(s) or other normative document(s)

- | | | | |
|--|--------|--|--------|
| <input checked="" type="checkbox"/> EN 61204-3 | (2000) | <input checked="" type="checkbox"/> IEC 61000-4-2 | (2001) |
| <input checked="" type="checkbox"/> CISPR 22 | (1997) | <input checked="" type="checkbox"/> IEC 61000-4-3 | (2002) |
| <input checked="" type="checkbox"/> EN 61000-3-2 | (2000) | <input checked="" type="checkbox"/> IEC 61000-4-4 | (2004) |
| <input checked="" type="checkbox"/> EN 61000-3-3 | (1995) | <input checked="" type="checkbox"/> IEC 61000-4-5 | (2001) |
| + A1 | (2001) | <input checked="" type="checkbox"/> IEC 61000-4-6 | (2003) |
| | | + A1 | (2004) |
| | | <input checked="" type="checkbox"/> IEC 61000-4-11 | (2004) |

following the provisions of 2004/108/EC Directive

Place: _____ Signature: _____

Date : _____ Full name: _____



Title: _____

TÜV Rheinland Taiwan Ltd.



Certificate of Appointment

for the applicant:

Hometek Technology Inc.
No. 67-9, Shir Men Rd., Tu-Cheng City,
Taipei Hsien 236, Taiwan, R.O.C.

has been authorized to carry out EMC tests by order and under supervision of TÜV Rheinland. It has successfully demonstrated capability to conduct measurement and to process test data according to:

**European and International EMC Standards as listed in the
Scope of Authorization on the attachment to this certificate**

An assessment of the facility was conducted by TÜV Rheinland auditors according to the TÜV Rheinland requirements for "Test Site Approval" with reference to

ISO 17 025:1999

Certificate No. : 10012161-2004

Valid until : February 14, 2006

TÜV Rheinland Taiwan Ltd.
Taipei, December 21, 2004

Dipl.-Ing. Andreas Klinker
Certification Body

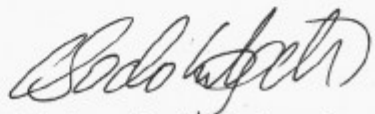
Dipl.-Ing. Bodo Kretzschmar
Product Safety and Quality



Attachment to
Certificate
of Appointment

SCOPE OF AUTHORIZATION

Hometek Technology Inc.
No. 67-9, Shir Men Rd., Tu-Cheng City,
Taipei Hsien 236, Taiwan, R.O.C.

European Standards

EN 50081-1	EN 61000-3-2	ENV 50140
EN 50081-2	EN 61000-3-3	ENV 50141
EN 50082-1	EN 61000-6-1	ENV 50204
EN 50130-4	EN 61000-6-2	
EN 50091-2	EN 61000-6-3	
EN 55011	EN 61000-6-4	
EN 55013	EN 61000-3-11	
EN 55014-1	EN 61000-4-2	
EN 55014-2	EN 61000-4-3	
EN 55022	EN 61000-4-4	
EN 55024	EN 61000-4-5	
EN 60601-1-2	EN 61000-4-6	
EN 60801	EN 61000-4-8	
EN 60945	EN 61000-4-11	
	EN 61204-3	

International Standards

CISPR 11	IEC 61000-4-2	IEC 61000-3-2
CISPR 13	IEC 61000-4-3	IEC 61000-3-3
CISPR 14-1	IEC 61000-4-4	IEC 61000-3-11
CISPR 14-2	IEC 61000-4-5	IEC 61000-6-1
CISPR 22	IEC 61000-4-6	IEC 61000-6-2
CISPR 24	IEC 61000-4-8	IEC 61000-6-3
	IEC 61000-4-11	IEC 61000-6-4
IEC 801.2	IEC 61000-4-12	IEC 60945
IEC 801.3		
IEC 801.4		

Certificate No. : 10012161-2004

Taipei, December 21 , 2004

Dipl.-Ing. Bodo Krätzschar
Product Safety and Quality



TÜV Rheinland Taiwan Ltd.

Certificate

of

Appointment

for the applicant:

Hometek Technology Inc.
No. 67-9, Shir Men Rd., Tu-Cheng City,
Taipei Hsien 236, Taiwan, R.O.C.

has been authorized to carry out EMC tests by order and under supervision of TÜV Rheinland. It has successfully demonstrated capability to conduct measurement and to process test data according to:

**European and International EMC Standards as listed in the
Scope of Authorization on the attachment to this certificate**

An assessment of the facility was conducted by TÜV Rheinland auditors according to the TÜV Rheinland requirements for "Test Site Approval" with reference to

ISO 17 025:1999

Certificate No. : 10012161-2006

Valid until : June 14, 2007

TÜV Rheinland Taiwan Ltd.
Taipei, April 13, 2006

Dipl.-Ing. Andreas Klinker
Certification Body

Dipl.-Ing. Bodo Kretzschmar
Product Safety and Quality



Attachment to
Certificate
of Appointment

SCOPE OF AUTHORIZATION

Hometek Technology Inc.
No. 67-9, Shir Men Rd., Tu-Cheng City,
Taipei Hsien 236, Taiwan, R.O.C.

European Standards

EN 50081-1	EN 61000-3-2	ENV 50140
EN 50081-2	EN 61000-3-3	ENV 50141
EN 50082-1	EN 61000-6-1	ENV 50204
EN 50130-4	EN 61000-6-2	
EN 50091-2	EN 61000-6-3	
EN 55011	EN 61000-6-4	
EN 55013	EN 61000-3-11	
EN 55014-1	EN 61000-4-2	
EN 55014-2	EN 61000-4-3	
EN 55022	EN 61000-4-4	
EN 55024	EN 61000-4-5	
EN 60601-1-2	EN 61000-4-6	
EN 60801	EN 61000-4-8	
EN 60945	EN 61000-4-11	
	EN 61204-3	

International Standards

CISPR 11	IEC 61000-4-2	IEC 61000-3-2
CISPR 13	IEC 61000-4-3	IEC 61000-3-3
CISPR 14-1	IEC 61000-4-4	IEC 61000-3-11
CISPR 14-2	IEC 61000-4-5	IEC 61000-6-1
CISPR 22	IEC 61000-4-6	IEC 61000-6-2
CISPR 24	IEC 61000-4-8	IEC 61000-6-3
	IEC 61000-4-11	IEC 61000-6-4
IEC 801.2	IEC 61000-4-12	IEC 60945
IEC 801.3		
IEC 801.4		

Certificate No. : 10012161-2006

Taipei, April 13, 2006

Dipl.-Ing. Bodo Kretzschmar
Product Safety and Quality



TÜV Rheinland Taiwan Ltd.

Certificate of Appointment

for the applicant:

**Hometek Technology Inc.
No. 67-9, Shir Men Rd., Tu-Cheng City,
Taipei Hsien 236, Taiwan, R.O.C.**

has been authorized to carry out EMC tests by order and under supervision of TÜV Rheinland. It has successfully demonstrated capability to conduct measurement and to process test data according to:

**European and International EMC Standards as listed in the
Scope of Authorization on the attachment to this certificate**

An assessment of the facility was conducted by TÜV Rheinland auditors according to the TÜV Rheinland requirements for "Test Site Approval" with reference to

ISO 17025: 2005

Certificate No. : 10012161-2007

Valid until : Sept. 7, 2008

TÜV Rheinland Taiwan Ltd.
Taipei, June 20, 2007

Dipl.-Ing. Andreas Klinker
Certification Body

Dipl.-Ing. Bodo Kretzschmar
Product Safety and Quality



Attachment to
Certificate

of Appointment

SCOPE OF AUTHORIZATION

Hometek Technology Inc.
No. 67-9, Shir Men Rd., Tu-Cheng City,
Taipei Hsien 236, Taiwan, R.O.C.

European Standards

EN 50081-1	EN 61000-3-3	ENV 50140
EN 50081-2	EN 61000-6-1	ENV 50141
EN 50082-1	EN 61000-6-2	ENV 50204
EN 50130-4	EN 61000-6-3	
EN 50091-2	EN 61000-6-4	
EN 55011	EN 61000-3-11	
EN 55013	EN 61000-4-2	
EN 55014-1	EN 61000-4-3	
EN 55014-2	EN 61000-4-4	
EN 55022	EN 61000-4-5	
EN 55024	EN 61000-4-6	
EN 60601-1-2	EN 61000-4-8	
EN 60801	EN 61000-4-11	
EN 60945	EN 61204-3	
EN 61000-3-2	EN 62040-2	

International Standards

CISPR 11	IEC 61000-4-2	IEC 61000-3-2
CISPR 13	IEC 61000-4-3	IEC 61000-3-3
CISPR 14-1	IEC 61000-4-4	IEC 61000-3-11
CISPR 14-2	IEC 61000-4-5	IEC 61000-6-1
CISPR 22	IEC 61000-4-6	IEC 61000-6-2
CISPR 24	IEC 61000-4-8	IEC 61000-6-3
IEC 801.2	IEC 61000-4-11	IEC 61000-6-4
IEC 801.3	IEC 61000-4-12	IEC 60945
IEC 801.4		IEC 62040-2

Certificate No. : 10012161-2007

Taipei, June 20, 2007

Dipl.-Ing. Bodo Kretzschmar
Product Safety and Quality