



HomeTek Technology Inc.

ADDRESS: No. 67-9, Shir Men Road, Tu Cheng City, Taipei Hsien, Taiwan, R. O. C.

PHONE : 886-2-22608375 FAX : 886-2-22748013

E - mail : hometek@ms15.hinet.net

CERTIFICATE OF COMPLIANCE

EUT : Transmission

MODEL NO. : PCT0XX

Receipt Date : 12/13/2004 Final Test Date: 12/27/2004

REPORT # : EB3L030

APPLICANT : SMART CABLING & TRANSMISSION CORP.

ADDRESS : 7F-1, NO. 168, LIEN CHENG RD.,
CHUNG-HO CITY, TAIPEI HSIEN, TAIWAN, R. O. C.

Measurement procedure used:

EMI: EN 61000-6-3 (2001): CISPR 22 Class B (1997),
EN 61000-3-2 (2000), EN 61000-3-3 (1995) + A1 (2001)

EMS: EN 50130-4 (1996) + A1 (1998):
IEC 61000-4-2 (2001), IEC 61000-4-3 (2002), IEC 61000-4-4 (2004),
IEC 61000-4-5 (2001), ENV 50141 (1993), IEC 61000-4-11 (2004)

We hereby show that:

The measurements shown in this test report were made in accordance with the procedures given in **EUROPEAN COUNCIL DIRECTIVE 89/336/EEC**, and the energy emitted by the equipment was found to be within the limits applicable.

This test result of this report applies to above tested sample only.

This test report shall not be reproduce in part without written approval of HomeTek Technology Inc.

PREPARED BY : Ming Yu Li DATE : 1/26/2005
MING YU LI

CHECK BY : Albert Tsai DATE : 1/26/2005
ALBERT TSAI / Senior Engineer

APPROVED BY : Tommy Rau DATE : 1/26/2005
TOMMY RAU / Manager



TABLE OF CONTENTS.....1

GENERAL INFORMATION.....4

MODIFICATION LIST.....5

CONDUCTED POWER LINE TEST.....6

1 TEST INSTRUMENTS & FACILITIES6

2 TEST PROCEDURE.....6

3 TEST SETUP7

4 CONFIGURATION OF THE EUT.....9

5 EUT OPERATING CONDITION.....12

6 LIMIT OF CONDUCTED POWER LINE EMISSION CLASS B.....12

7 RESULT OF CONDUCTED POWER LINE TEST12

8 CONDUCTED POWER LINE TEST DATA (PAGE 1)13

9 CONDUCTED POWER LINE TEST DATA (PAGE 2)14

10 CONDUCTED POWER LINE TEST DATA (PAGE 3)15

11 CONDUCTED POWER LINE TEST DATA (PAGE 4)16

RADIATED EMISSION TEST 17

1 TEST INSTRUMENTS & FACILITIES17

2 TEST PROCEDURE.....18

3 TEST SETUP18

4 CONFIGURATION OF THE EUT.....19

5 EUT OPERATING CONDITION.....19

6 LIMIT OF RADIATED EMISSION CLASS B.....19

7 RESULT OF RADIATED EMISSION TEST19

8 RADIATED EMISSION TEST DATA (PAGE 1).....20

9 RADIATED EMISSION TEST DATA (PAGE 2).....21

HARMONICS TEST..... 22

1 TEST INSTRUMENTS & FACILITIES22

2 TEST PROCEDURE.....22

3 TEST SETUP22

4 CONFIGURATION OF THE EUT.....22

5 OPERATION CONDITION OF EUT22

6 TEST DATA & LIMIT.....22

7 PHOTOS OF TEST CONFIGURATION PLEASE REFER TO APPENDIX A.22

8 HARMONICS TEST DATA (PAGE 1~2).....23

VOLTAGE FLUCTUATIONS TEST..... 25

1 TEST INSTRUMENTS & FACILITIES25

2 TEST PROCEDURE.....25

3 TEST SETUP25



4	CONFIGURATION OF THE EUT.....	25
5	OPERATION CONDITION OF EUT.....	25
6	TEST DATA & LIMIT.....	25
7	PHOTOS OF TEST CONFIGURATION PLEASE REFER TO APPENDIX A.	25
8	VOLTAGE FLUCTUATIONS TEST DATA (PAGE 1).....	26
ELECTROSTATIC DISCHARGE IMMUNITY TEST (ESD)		27
1	TEST INSTRUMENTS & FACILITIES	27
2	TEST PROCEDURE.....	27
3	TEST SETUP	27
4	CONFIGURATION OF THE EUT.....	28
5	EUT OPERATION CONDITION	28
6	TEST CONDITION.....	28
7	PERFORMANCE CRITERIA	28
8	TEST RESULT.....	29
RADIO FREQUENCY ELECTROMAGNETIC FIELD IMMUNITY TEST (RS).....		30
1	TEST INSTRUMENTS & FACILITIES	30
2	TEST PROCEDURE.....	30
3	TEST SETUP.....	31
4	CONFIGURATION OF THE EUT.....	32
5	OPERATION CONDITION OF EUT.....	32
6	TEST CONDITION.....	32
7	PERFORMANCE CRITERIA	32
8	TEST RESULT.....	33
ELECTRICAL FAST TRANSIENT/BURST IMMUNITY TEST (EFT)		34
1	TEST INSTRUMENTS & FACILITIES	34
2	TEST PROCEDURE.....	34
3	TEST SETUP.....	34
4	CONFIGURATION OF THE EUT.....	35
5	OPERATION CONDITION OF EUT.....	35
6	TEST CONDITION.....	35
7	PERFORMANCE CRITERIA	35
8	TEST RESULT.....	36
SURGE IMMUNITY TEST.....		37
1	TEST INSTRUMENTS & FACILITIES	37
2	TEST PROCEDURE.....	37
3	TEST SETUP.....	37
4	TEST LEVELS.....	38
5	CONFIGURATION OF THE EUT.....	38
6	EUT OPERATION CONDITION	38



7	CONDITIONS DURING TESTING.....	39
8	PERFORMANCE CRITERIA	39
9	TEST RESULT	40
IMMUNITY TEST TO CS CONDUCTED DISTURBANCE.....		41
1	TEST INSTRUMENTS & FACILITIES	41
2	TEST PROCEDURE.....	41
3	TEST SETUP	42
4	TEST LEVELS.....	43
5	CONFIGURATION OF THE EUT.....	43
6	EUT OPERATION CONDITION	43
7	CONDITIONS DURING TESTING.....	43
8	PERFORMANCE CRITERIA	44
9	TEST RESULT	44
VOLTAGE DIPS, SHORT INTERRUPTIONS IMMUNITY TEST AND MAIN SUPPLY VARIATIONS.....		45
1	TEST INSTRUMENTS & FACILITIES	45
2	TEST PROCEDURE.....	45
3	TEST SETUP	45
4	TEST LEVELS FOR DIPS.....	46
5	CONFIGURATION OF THE EUT.....	46
6	EUT OPERATION CONDITION	46
7	CONDITIONS DURING TESTING.....	46
8	PERFORMANCE CRITERIA	47
9	TEST RESULT	47
10	TEST LEVELS FOR MAIN SUPPLY VARIATIONS	48
11	PERFORMANCE CRITERIA	48
12	TEST RESULT	48

APPENDIX A

PHOTOS OF TEST CONFIGURATION

APPENDIX B

PHOTOS OF EUT



GENERAL INFORMATION

- 1 APPLICANT : SMART CABLING & TRANSMISSION CORP.
- 2 ADDRESS : 7F-1, No. 168, Lien Cheng Rd.,
Chung-Ho City, Taipei Hsien, Taiwan, R. O. C.
- 3 MANUFACTURER : SMART CABLING & TRANSMISSION CORP.
- 4 ADDRESS : 7F-1, No. 168, Lien Cheng Rd.,
Chung-Ho City, Taipei Hsien, Taiwan, R. O. C.
- 5 DESCRIPTION OF EUT :
EUT : Transmission
Model : PCT0XX
Serial # : N/A

5.1 The difference between series of models PCT0XX is different operation system. The worst case of EMC test model is PCT017 and the final test data were shown in this test report.

- 6 FEATURES OF EUT :

Please refer to user manual or product specification.



HomeTek Technology Inc.

MODIFICATION LIST

THE FOLLOWING ACCESSORIES WERE ADDED TO THE EUT DURING TESTING :

NO MODIFICATION BY HOMETEK TECHNOLOGY INC.



CONDUCTED POWER LINE TEST

1 TEST INSTRUMENTS & FACILITIES

The following test Instruments was used during the conducted test :

Item	Instruments/ Facilities	Specification	Manufacturer	Model #	Date Of Cal.
1	EMI Receiver	9KHz ~ 30MHz	ROHDE & SCHWARZ	ESHS 30 844827/007	MAR/2004
2	LISN (for EUT)	50 /50uH/100A 150KHz ~ 30MHz	SCHWARZ BECK	NNLK 8121 8121370	OCT/2004
3	LISN (for Support Unit)	50 /50uH/10A 9KHz ~ 30MHz	ROHDE & SCHWARZ	ESH3-Z5 846128/007	FEB/2004
4	Terminator	50	N/A	N/A	NOV/2004
5	Attenuation	50 /10dB	Mini-Circuit	NAT-10 AT-002	JUL/2004
6	Cable	5.4m	SUHNER	RG-223 CON2-002	AUG/2004
7	ESXS-K1 (software)	Version 2.03b 9KHz ~ 30MHz	ROHDE & SCHWARZ	1082.9678.02 840.913/246	N/A

Note : Items 1 ~ 6 were calibrated within period of 1 year.

2 TEST PROCEDURE

- 2.1 The EUT was tested according to **EN 61000-6-3**.
- 2.2 The EUT was placed 0.4 meter from the conducting wall of shielding room and kept at least 0.8 meter from any other grounded conducting surface.
- 2.3 The frequency range form 0.15 MHz to 30 MHz was investigated.
- 2.4 The LISN used was 50 Ohm / 50 uHenry as specified by **CISPR 22 Class B**.
- 2.5 All the support peripherals are connect to the other LISN.
- 2.6 Cables and peripherals were moved to find the maximum emission levels for each frequency.

3 TEST SETUP

3.1 Typical : Setup Of Conducted Test

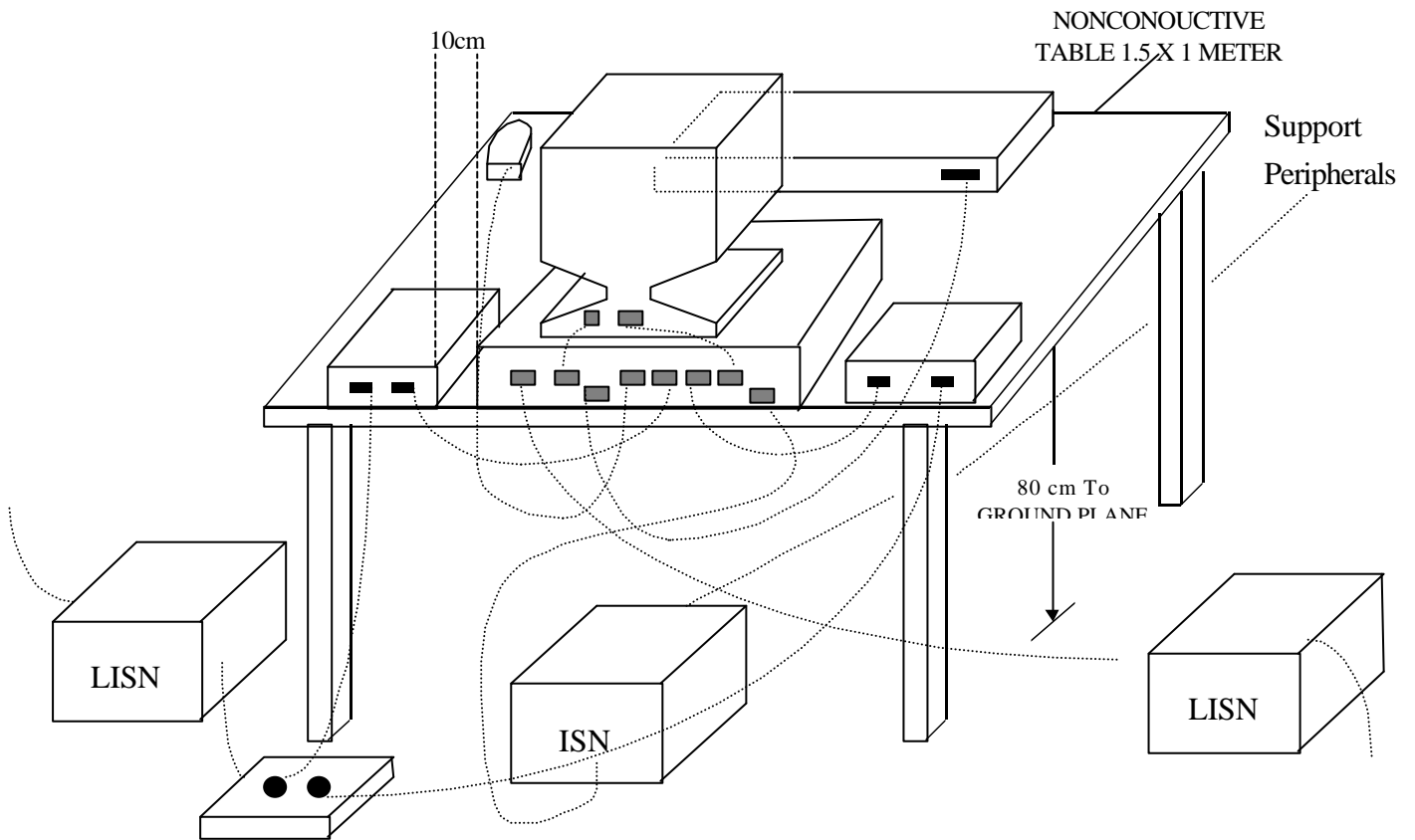

(Details for setup configuration, please refer to appendix A.)

3.2 Block Diagram Of Conducted Test

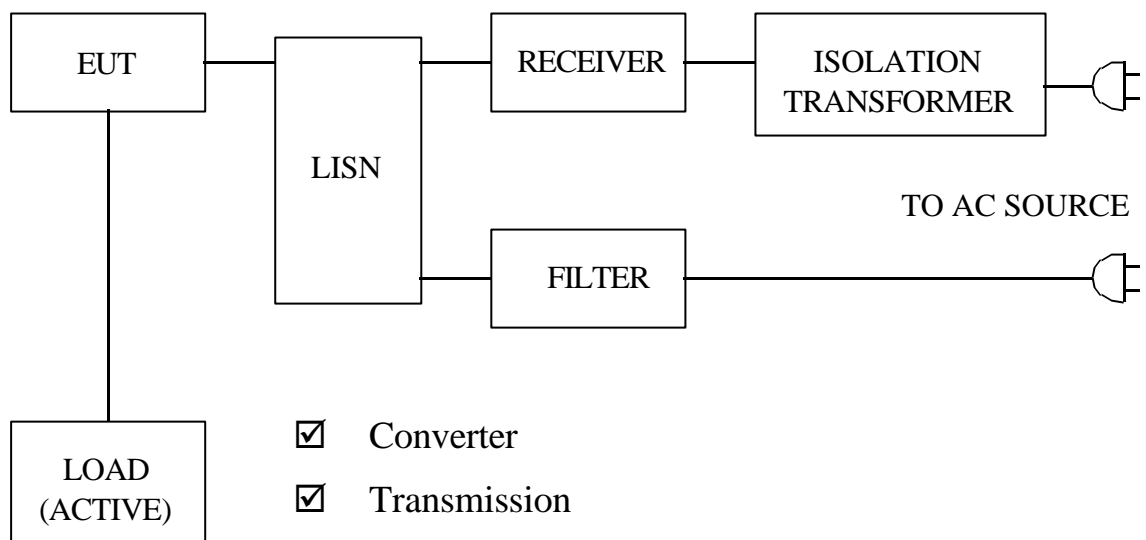

4 CONFIGURATION OF THE EUT

The EUT was configured according to **EN 61000-6-3**. All I/O ports were connected to the appropriate peripherals. All peripherals and cables are listed below (including internal device) :

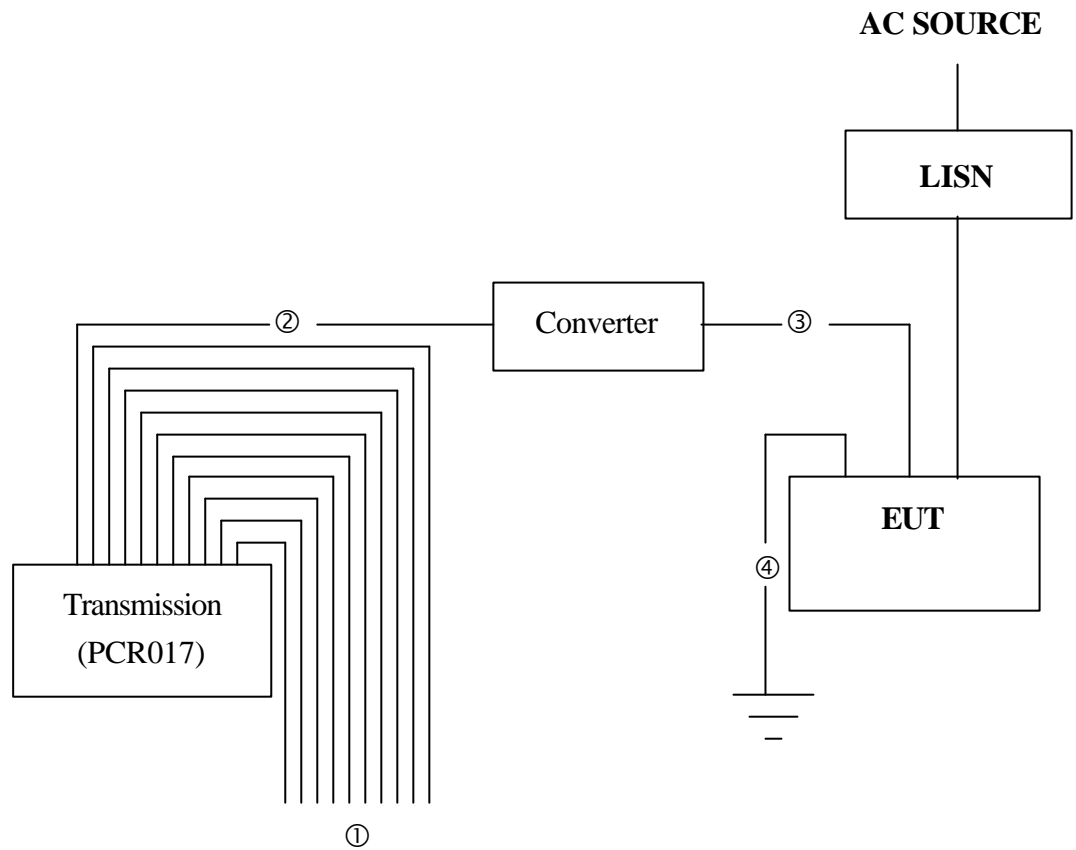

- ① Data cable floating x10
- ② Twisted Pair Cable
- ③ Twisted Pair Cable
- ④ Connect to Ground

Figure 1



4.1 EUT

EUT Type : Proto Type Engineer Type Mass Production
Condition when received : Good Damage : _____
Device : Transmission
Applicant : SMART CABLING & TRANSMISSION CORP.
Manufacturer : SMART CABLING & TRANSMISSION CORP.
Model Number : PCT0XX
Serial Number : N/A
FCC ID : N/A
Serial Port : Metal Type Connector
Ground : Un-Shielded, 2.0 m, Metal Type Connector
Power Cord (AC) : 2 pin
Power Cord (DC) : Un-Shielded, 1.8 m, 2 pin
Power Supply Type : Linear Adapter

4.2 PERIPHERALS

Transmission
Manufacturer : SMART CABLING & TRANSMISSION CORP.
Model Number : PCR017
Serial Number : N/A
FCC ID : N/A
Data Cable 1 : Un-Shielded, 1.0 m
Data Cable 2 : Un-Shielded, 2.5 m
Power Cord : Un-Shielded, 1.8 m



Converter

Manufacturer : SMART CABLING & TRANSMISSION CORP.
Model Number : RS001
Serial Number : N/A
FCC ID : N/A
Data Cable : Un-Shielded, 0.1 m, Connected to the Serial Port
Power Cord : N/A

AC Adapter

Manufacturer : ELEC
Model Number : YAD-1200500E
Serial Number : N/A
FCC ID : N/A
Data Cable : N/A
Power Cord : Un-Shielded, 1.8 m

4.3 REMARK : N/A



5 EUT OPERATING CONDITION

- 5.1 The frequency of the EUT is 4 MHz.
- 5.2 Configure the EUT according to the **EN 61000-6-3**.
- 5.3 Turn on all the power of EUT and peripheral
- 5.4 EUT's serial port connected with the RS232 Port of Support Unit1(Converter RS001) via 0.1m cable
- 5.5 RS485 Port of Support Unit1(Converter RS001) connected with the serial port of Support Unit2(Transmission PCR017) via 2.5m cable
- 5.6 EUT take control of all relay of transmission (PCR017)
- 5.7 Monitor the status of output port of EUT during the test (For EMS Testing)
- 5.8 The photos of conducted test configuration, please refer to appendix A.**

6 LIMIT OF CONDUCTED POWER LINE EMISSION CLASS B

Frequency Range	Quasi Peak	Average
0.15 ~ 0.5 MHz	66 - 56 dBuV	56 - 46 dBuV
0.5 ~ 5 MHz	56 dBuV	46 dBuV
5 ~ 30 MHz	60 dBuV	50 dBuV

7 RESULT OF CONDUCTED POWER LINE TEST

- 7.1 The frequency range from 0.15 MHz to 30 MHz was investigated. All readings are quasi-peak values and average.
- 7.2 IF bandwidth : 9 kHz, Meas Time : 1 sec.
- 7.3 Temperature : 27 , Humidity : 60 % RH.
- 7.4 Deviations from the test standards and rules : None.
- 7.5 The conducted test result were gained by following procedures :
 Level = Reading Level + Insertion Loss of LISN + Cable Loss
 (All calculation were done by ESHS30 EMI test receiver.)
- 7.6 Result : **PASSED**



8 CONDUCTED POWER LINE TEST DATA (PAGE 1)

HomeTek EMC LAB. TEL :886-2-22608375

16 Dec 2004 11:11

CONDUCTED EMISSIONS

EUT: Transmission
Manuf: 3L030
Op Cond: LINE 1
Operator: VIC
Test Spec: FOR CISPR22 CLASS B
Comment: 230V/50Hz
PCT017
Result File: 303011c.dat : New Measurement

Prescan Measurement: Detectors: X PK / + AV
 Meas Time: see scan settings
 Subranges: 16
 Acc Margin: 55 dB

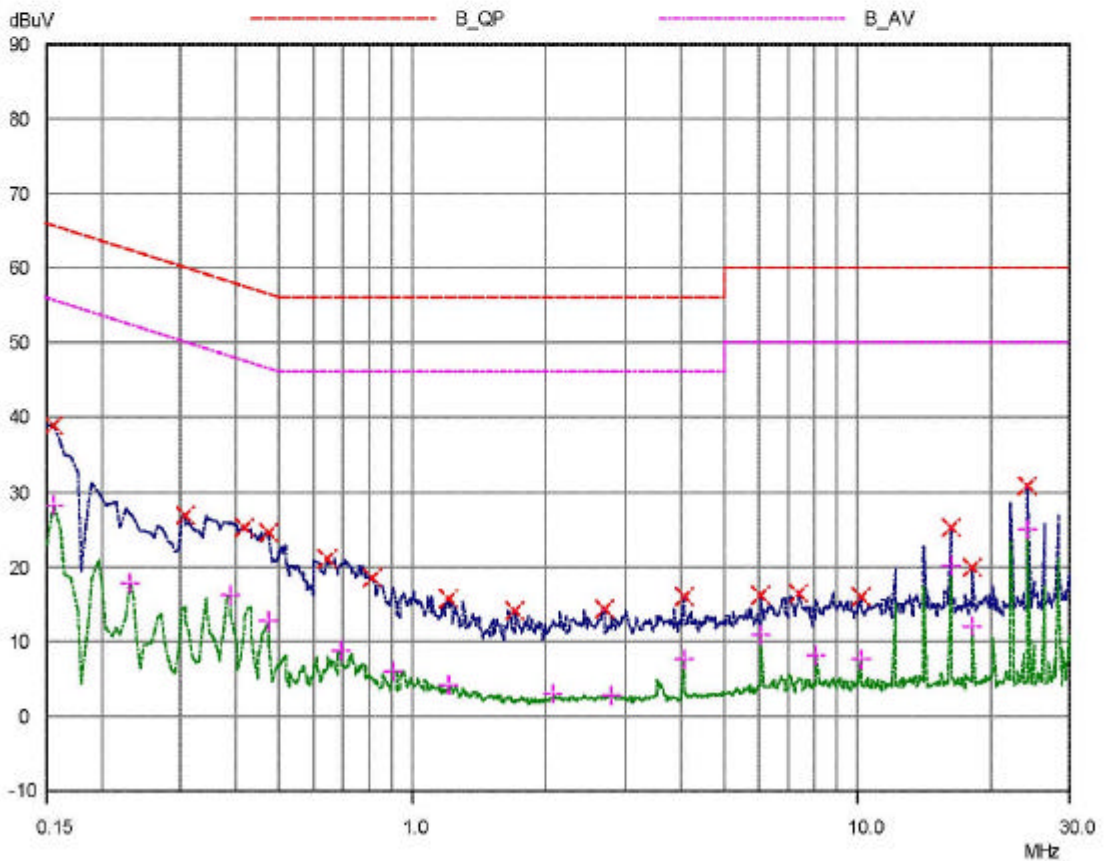



9 CONDUCTED POWER LINE TEST DATA (PAGE 2)

HomeTek EMC LAB. TEL :886-2-22608375

16 Dec 2004 11:11

CONDUCTED EMISSIONS

EUT: Transmission
 Manuf: 3L030
 Op Cond: LINE 1
 Operator: VIC
 Test Spec: FOR CISPR22 CLASS B
 Comment: 230V/50Hz
 PCT017
 Result File: 303011c.dat : New Measurement

Prescan Measurement: Detectors: X PK / + AV
 Meas Time: see scan settings
 Subranges: 16
 Acc Margin: 55 dB

Peak Search Results

Frequency MHz	PK Level dBuV	PK Limit dBuV	PK Delta dB
0.155	38.87	65.73	26.86
0.305	26.86	60.11	33.25
0.42	25.31	57.45	32.14
0.47	24.47	56.51	32.04
0.64	21.15	56.00	34.85
0.81	18.60	56.00	37.40
1.2	15.77	56.00	40.23
1.7	14.02	56.00	41.98
2.69	14.44	56.00	41.56
4.03	16.10	56.00	39.90
6.04	16.20	60.00	43.80
7.37	16.51	60.00	43.49
10.05	16.09	60.00	43.91
16.07998	25.26	60.00	34.74
18.09	19.97	60.00	40.03
24.12	30.71	60.00	29.29

Frequency MHz	AV Level dBuV	AV Limit dBuV	AV Delta dB
0.155	28.28	55.73	27.45
0.23	17.94	52.45	34.51
0.385	16.31	48.17	31.86
0.47	12.63	46.51	33.88
0.685	8.77	46.00	37.23
0.9	6.04	46.00	39.96
1.21	4.08	46.00	41.92
2.06	3.01	46.00	42.99
2.77	2.72	46.00	43.28
4.03	7.76	46.00	38.24
6.04	10.81	50.00	39.19
8.03998	8.07	50.00	41.93
10.05	7.70	50.00	42.30
16.07998	20.17	50.00	29.83
18.09	12.09	50.00	37.91
24.12	25.02	50.00	24.98

* limit exceeded



10 CONDUCTED POWER LINE TEST DATA (PAGE 3)

HomeTek EMC LAB. TEL :886-2-22608375

16 Dec 2004 11:07

CONDUCTED EMISSIONS

EUT: Transmission
Manuf: 3L030
Op Cond: LINE 2
Operator: VIC
Test Spec: FOR CISPR22 CLASS B
Comment: 230V/50Hz
PCT017
Result File: 303021c.dat : New Measurement

Prescan Measurement: Detectors: X PK / + AV
 Meas Time: see scan settings
 Subranges: 16
 Acc Margin: 55 dB

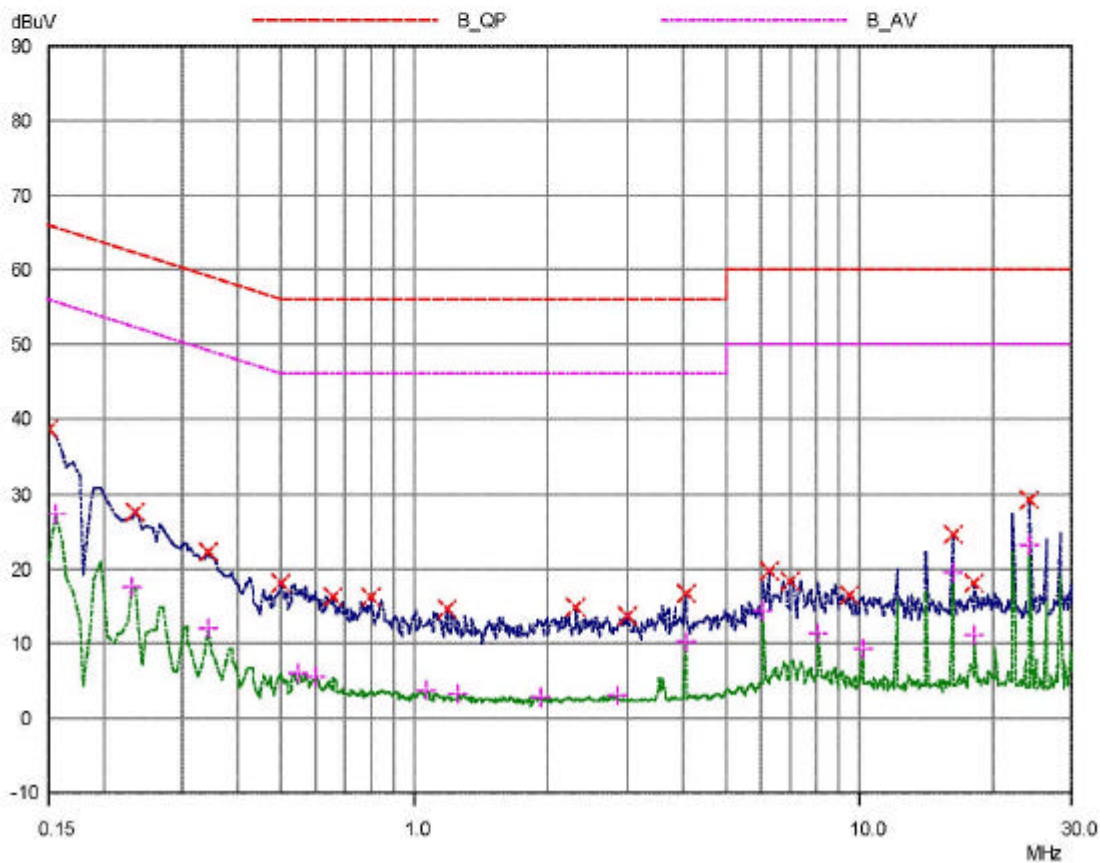



11 CONDUCTED POWER LINE TEST DATA (PAGE 4)

HomeTek EMC LAB. TEL :886-2-22608375

16 Dec 2004 11:07

CONDUCTED EMISSIONS

EUT: Transmission
 Manuf: 3L030
 Op Cond: LINE 2
 Operator: VIC
 Test Spec: FOR CISPR22 CLASS B
 Comment: 230V/50Hz
 PCT017
 Result File: 303021c.dat : New Measurement

Prescan Measurement: Detectors: X PK / + AV
 Meas Time: see scan settings
 Subranges: 16
 Acc Margin: 55 dB

Peak Search Results

Frequency MHz	PK Level dBuV	PK Limit dBuV	PK Delta dB
0.15	38.71	66.00	27.29
0.235	27.49	62.27	34.78
0.34	22.34	59.20	36.86
0.5	18.05	56.00	37.95
0.655	16.25	56.00	39.75
0.8	16.33	56.00	39.67
1.17	14.49	56.00	41.51
2.3	14.80	56.00	41.20
3.0	13.61	56.00	42.39
4.03	16.57	56.00	39.43
6.2	19.59	60.00	40.41
7.02	18.41	60.00	41.59
9.4	16.44	60.00	43.56
16.07998	24.54	60.00	35.46
18.09	18.15	60.00	41.85
24.12	29.09	60.00	30.91

Frequency MHz	AV Level dBuV	AV Limit dBuV	AV Delta dB
0.155	27.42	55.73	28.31
0.23	17.68	52.45	34.77
0.345	11.99	49.08	37.09
0.55	6.02	46.00	39.98
0.6	5.64	46.00	40.36
1.06	3.75	46.00	42.25
1.25	3.28	46.00	42.72
1.91	2.89	46.00	43.11
2.83	2.96	46.00	43.04
4.03	10.19	46.00	35.81
6.04	14.29	50.00	35.71
8.03998	11.29	50.00	38.71
10.05	9.34	50.00	40.66
16.07998	19.37	50.00	30.63
18.09	11.03	50.00	38.97
24.12	23.13	50.00	26.87

* limit exceeded



RADIATED EMISSION TEST

1 TEST INSTRUMENTS & FACILITIES

The following test Instruments was used during the radiated emission test :

Item	Instruments /facilities	Specification	Manufacturer	Model # / S/N#	Date of Cal.
1	OPEN AREA TEST SITE	<input checked="" type="checkbox"/> OATS 3			JUL/2004
2	EMI TEST RECEIVER	20Hz ~ 26.5GHz	ROHDE & SCHWARZ	ESMI 845442/006	JAN/2004
3	PRE-AMPLIFIER	9KHz ~ 3000MHz	ADVANTEST	BB525C 90081001	SEP/2004
4	ANTENNA (BI-LOG)	25MHz ~ 2GHz	SCHAFFNER	CBL6112B S/N : 2614	MAY/2004
5	Attenuation	50 /6dB	JYE BAO	FAT-N (M-F) 001	JUL/2004
6	Cable	10m	SUHNER	RG214/U OS3-003	DEC/2004
7	Cable	14m	BELDEN	9913 OS3-001	DEC/2004
8	EMI 32 (software)	N/A	AUDIX	19991013-0923	N/A

Note : Items 1 ~ 7 were calibrated within period of 1 year.

2 TEST PROCEDURE

- 2.1 The EUT was test according to **CISPR 22 Class B**.
- 2.2 The radiated test was performed at HomeTek Lab's Open Site **III**.
- 2.3 The frequency range from 30 MHz to 1 GHz, the measurement were made at 10 meters, with a BI-log antenna.

3 TEST SETUP

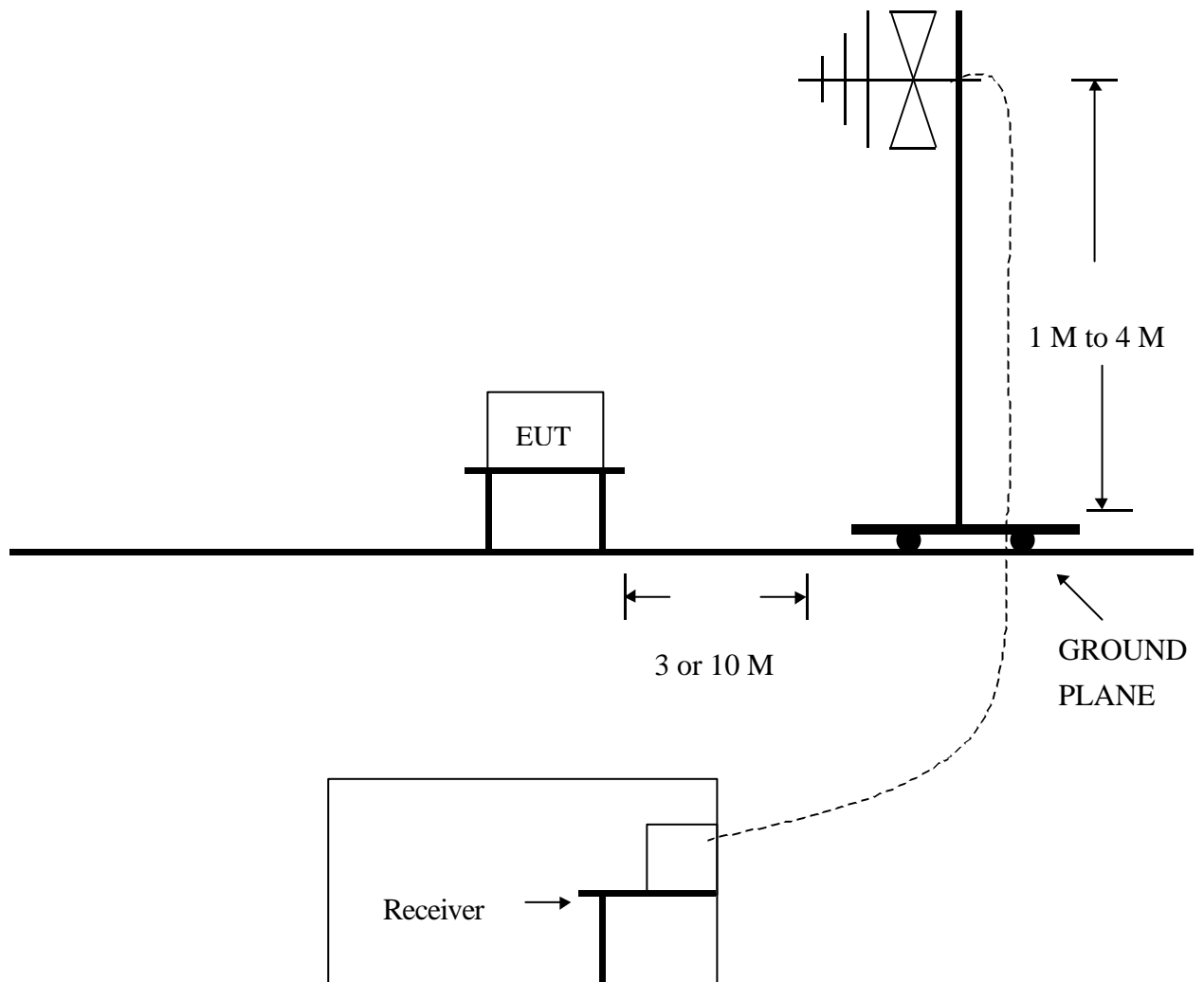

(Details for setup configuration, please refer to appendix A.)



4 CONFIGURATION OF THE EUT

Same as “Conducted Power Line test”, section 4

5 EUT OPERATING CONDITION

5.1 Same as “Conducted Power Line test”, section 5

5.2 The radiated emission in the frequency range from 30 MHz - 1000 MHz was test in a horizontal and vertical polarization at HomeTek Lab’s open site III.

5.3 The photos of radiated test configuration, please refer to appendix A.

6 LIMIT OF RADIATED EMISSION CLASS B

Frequency (MHz)	Measurement Distance	Limit (dBuV/m)
30 - 230	10 (M)	30
230 - 1000	10 (M)	37

7 RESULT OF RADIATED EMISSION TEST

7.1 The frequency range from 30 MHz to 1 GHz was investigated.

7.2 All readings below or equal 1 GHz are quasi-peak or peak values with resolution bandwidth of 120 KHz.

7.3 The measurements were made at 10 meters of HomeTek Lab’s open site III.

7.4 Temperature : 33 , Humidity : 55 % RH.

7.5 Deviation form the test standards and rules : None.

7.6 The radiated emission result were gained by the following method :

Level = Reading Level + Probe Factor (Antenna Factor) + Cable Loss – Preamp Factor

Over Limit = Level – Limit Line

7.7 Result : **PASSED**



HomeTek Technology Inc.

No 67-9, Shi-Men Rd., Tu-Chen City, Taipei County, Taiwan R.O.C. Tel: 02-22608375 Fax: 02-22748013

Data#: 1 File#: 31030.emi

Date: 2004-12-15 Time: 16:58:28

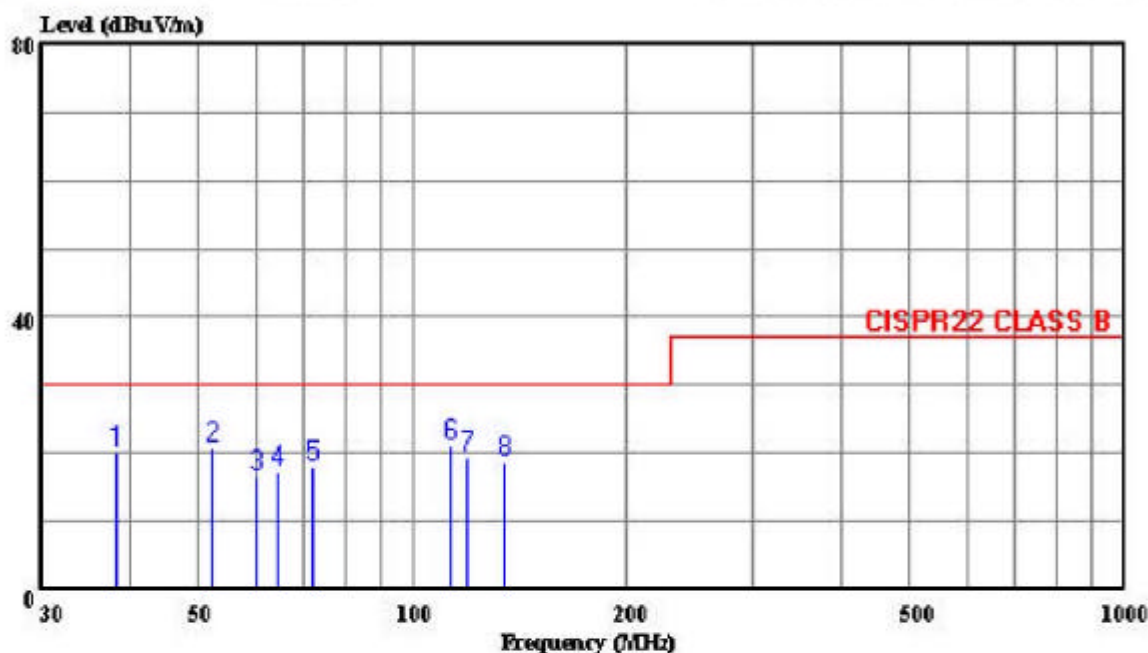

Trace:

Ref Trace:

Condition: CISPR22 CLASS B 10m CHASE 2614 052604 HORIZONTAL
cut : Transmission
power: 230V/50Hz
memo : PCT017

Page: 1

	Freq	Level	Limit	Over	ReadAntenna	Cable	Preamp	Remark
	MHz	dBuV/m	Line	Limit	Level	Loss	Factor	
			dBuV/m	dB	dBuV	dB	dB	
1	38.273	20.04	30.00	-9.96	35.82	13.17	0.94	29.89 Peak
2	52.260	20.69	30.00	-9.31	42.40	7.01	1.12	29.83 Peak
3	60.307	16.74	30.00	-13.26	39.58	5.68	1.17	29.70 Peak
4	64.253	17.17	30.00	-12.83	39.96	5.64	1.20	29.64 Peak
5	72.493	18.08	30.00	-11.92	40.27	6.04	1.27	29.50 Peak
6	112.507	21.14	30.00	-8.86	37.17	11.55	1.53	29.11 Peak
7	118.900	19.41	30.00	-10.59	35.32	11.68	1.56	29.15 Peak
8	134.220	18.78	30.00	-11.22	35.34	11.04	1.64	29.24 Peak



HomeTek Technology Inc.

No 67-9, Shi-Men Rd., Tu-Chen City, Taipei County, Taiwan R.O.C. Tel:02-22608375 Fax:02-22748013

Data#: 2 File#: 31030.emi

Date: 2004-12-15 Time: 17:20:49

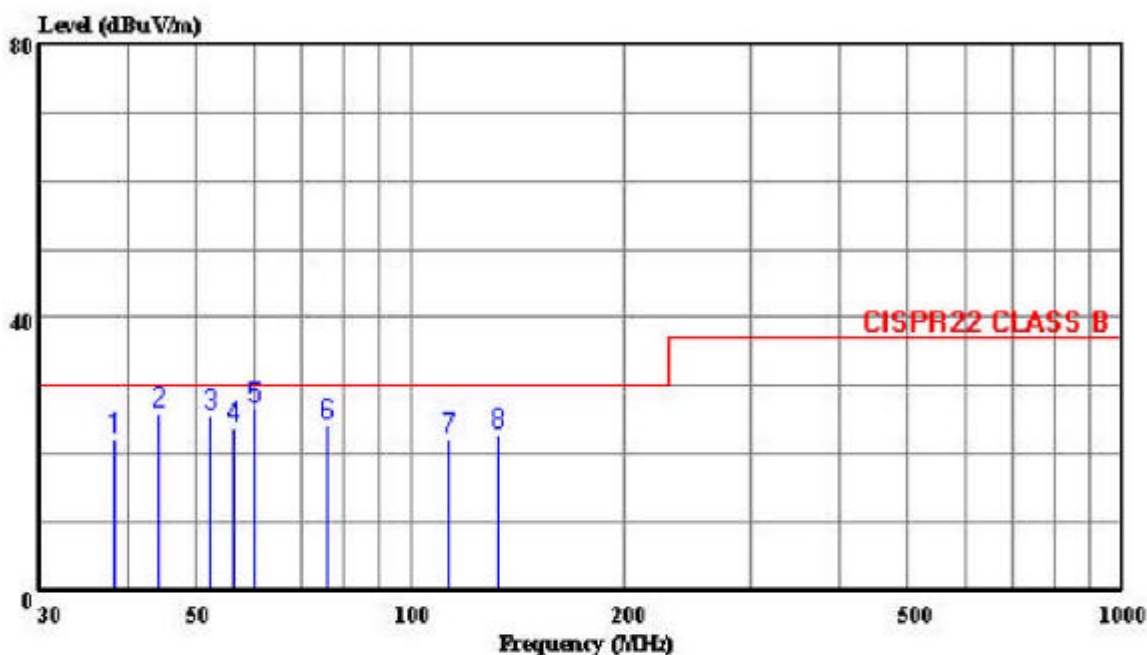

Trace:

Ref Trace:

Condition: CISPR22 CLASS B 10m CHASE 2614 052604 VERTICAL
cut : Transmission
power: 230V/50Hz
memo : PCT017

Page: 1

	Freq	Level	Limit	Over	ReadAntenna	Cable	Preamp	Remark
	MHz	dBuV/m	dBuV/m	dB	Level	Loss	Factor	
					Factor			
					dB/m	dB	dB	
1	38.244	22.33	30.00	-7.67	38.11	13.17	0.94	29.89 Peak
2	44.311	26.08	30.00	-3.92	44.05	10.89	1.03	29.89 Peak
3	52.262	25.72	30.00	-4.28	47.43	7.01	1.12	29.83 Peak
4	56.289	23.77	30.00	-6.23	46.18	6.21	1.14	29.77 Peak
5	60.304	26.51	30.00	-3.49	49.35	5.68	1.17	29.70 Peak
6	76.420	24.37	30.00	-5.63	46.03	6.48	1.29	29.43 Peak
7	112.538	22.20	30.00	-7.80	39.23	11.55	1.53	29.11 Peak
8	132.631	22.95	30.00	-7.05	39.39	11.16	1.63	29.23 Peak

HARMONICS TEST

1 TEST INSTRUMENTS & FACILITIES

Instruments/ facilities	Manufacturer	Model # Serial #	Date of Cal.
HARMONICS/ VOLTAGE FLUCTUATIONS TEST	EMC-PARTNER	HAR1000-1P	OCT/2004
CONTROL PC	KB TECH	KB P586/133	N/A

2 TEST PROCEDURE

According to **EN 61000-3-2 (2000) Class A**

3 TEST SETUP

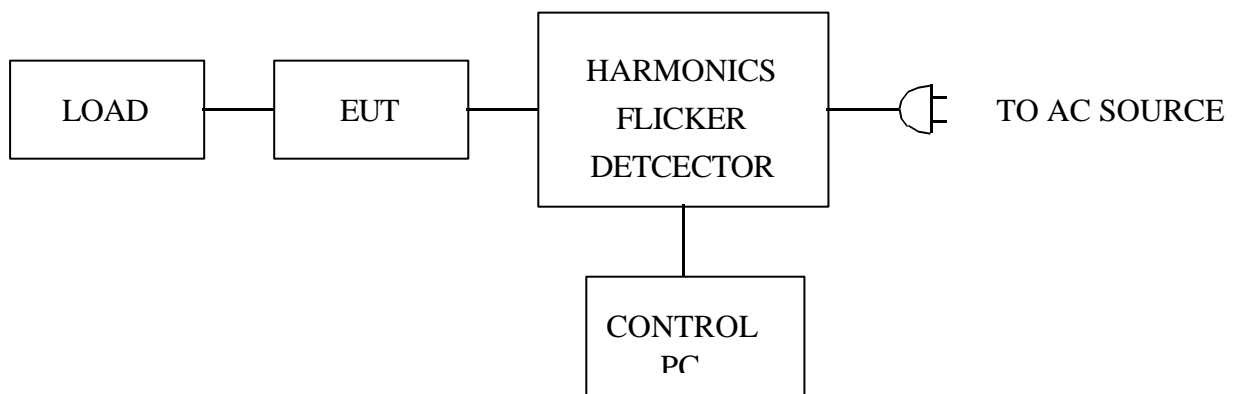

(Details for setup configuration, please refer to appendix A.)

4 CONFIGURATION OF THE EUT

Same as “Conducted Power Line test”, section 4

5 OPERATION CONDITION OF EUT

Same as “Conducted Power Line test”, section 5

6 TEST DATA & LIMIT

6.1 Temperature : 27

6.2 Humidity : 60 % RH

7 Photos of test configuration please refer to appendix A.



EMC PARTNER AG, SWITZERLAND

Date : 2004/12/16 03:57:59 V2.05

File :

Operator : VIC
 Unit : Transmission
 Serialnumber : PCT017
 Remarks : 3L030

Urms = 229.9V Freq = 49.984 Range: 0.25 A
 Irms = 0.035A Ipk = 0.063A cf = 1.810
 P = 4.908W Pap = 7.971VA pf = 0.616
 THDi = 41.3 % THDu = 0.10 % Class A

Test - Time : 15min (100 %)

Test completed, Result: PASSED

Order	Freq. [Hz]	Irms [A]	Imax [%]	Imax [A]	Imax%L [V]	Limit [deg]	Status	Vrms	Phase
1	50	0.0316	0.0316			229.94	0.00		
2	100	0.0003	0.0003	0.0667	1.0800		0.1227	0.00	
3	150	0.0099	0.0099	2.1600	2.3000		0.0000	0.00	
4	200	0.0002	0.0002	0.0333	0.4300		0.0000	0.00	
5	250	0.0102	0.0102	2.2367	1.1400		0.0000	0.00	
6	300	0.0001	0.0001	0.0133	0.3000		0.0000	0.00	
7	350	0.0006	0.0006	0.1400	0.7700		0.0000	0.00	
8	400	0.0000	0.0000	0.0066	0.2300		0.0000	0.00	
9	450	0.0005	0.0005	0.1100	0.4000		0.0000	0.00	
10	500	0.0000	0.0000	0.0000	0.1840		0.0000	0.00	
11	550	0.0010	0.0010	0.2233	0.3300		0.0000	0.00	
12	600	0.0000	0.0000	0.0100	0.1533		0.0000	0.00	
13	650	0.0003	0.0003	0.1526	0.2100		0.0000	0.00	
14	700	0.0000	0.0000	0.0000	0.1314		0.0000	0.00	
15	750	0.0004	0.0004	0.2543	0.1500		0.0000	0.00	
16	800	0.0000	0.0000	0.0000	0.1150		0.0000	0.00	
17	850	0.0003	0.0003	0.2190	0.1324		0.0000	0.00	
18	900	0.0000	0.0000	0.0000	0.1022		0.0000	0.00	
19	950	0.0002	0.0002	0.1288	0.1184		0.0000	0.00	
20	1000	0.0000	0.0000	0.0000	0.0920		0.0000	0.00	
21	1050	0.0002	0.0002	0.1709	0.1071		0.0000	0.00	
22	1100	0.0000	0.0000	0.0000	0.0836		0.0000	0.00	
23	1150	0.0001	0.0001	0.1248	0.0978		0.0000	0.00	
24	1200	0.0000	0.0000	0.0000	0.0767		0.0000	0.00	
25	1250	0.0001	0.0001	0.1187	0.0900		0.0000	0.00	



HomeTek Technology Inc.

26	1300	0.0000	0.0000	0.0000	0.0708	0.0000	0.00
27	1350	0.0001	0.0001	0.1282	0.0833	0.0000	0.00
28	1400	0.0000	0.0000	0.0000	0.0657	0.0000	0.00
29	1450	0.0001	0.0001	0.0787	0.0776	0.0000	0.00
30	1500	0.0000	0.0000	0.0000	0.0613	0.0000	0.00
31	1550	0.0001	0.0001	0.1051	0.0726	0.0000	0.00
32	1600	0.0000	0.0000	0.0000	0.0575	0.0000	0.00
33	1650	0.0001	0.0001	0.0895	0.0682	0.0000	0.00
34	1700	0.0000	0.0000	0.0000	0.0541	0.0000	0.00
35	1750	0.0000	0.0000	0.0712	0.0643	0.0000	0.00
36	1800	0.0000	0.0000	0.0000	0.0511	0.0000	0.00
37	1850	0.0000	0.0000	0.0753	0.0608	0.0000	0.00
38	1900	0.0000	0.0000	0.0000	0.0484	0.0000	0.00
39	1950	0.0000	0.0000	0.0529	0.0577	0.0000	0.00
40	2000	0.0000	0.0000	0.0000	0.0460	0.0000	0.00

VOLTAGE FLUCTUATIONS TEST

1 TEST INSTRUMENTS & FACILITIES

Instruments/ facilities	Manufacturer	Model # Serial #	Date of Cal.
HARMONICS/ VOLTAGE FLUCTUATIONS TEST	EMC-PARTNER	HAR1000-1P	OCT/2004
CONTROL PC	KB TECH	KB P586/133	N/A

2 TEST PROCEDURE

According to **EN 61000-3-3 (1995) + A1 (2001)**

3 TEST SETUP

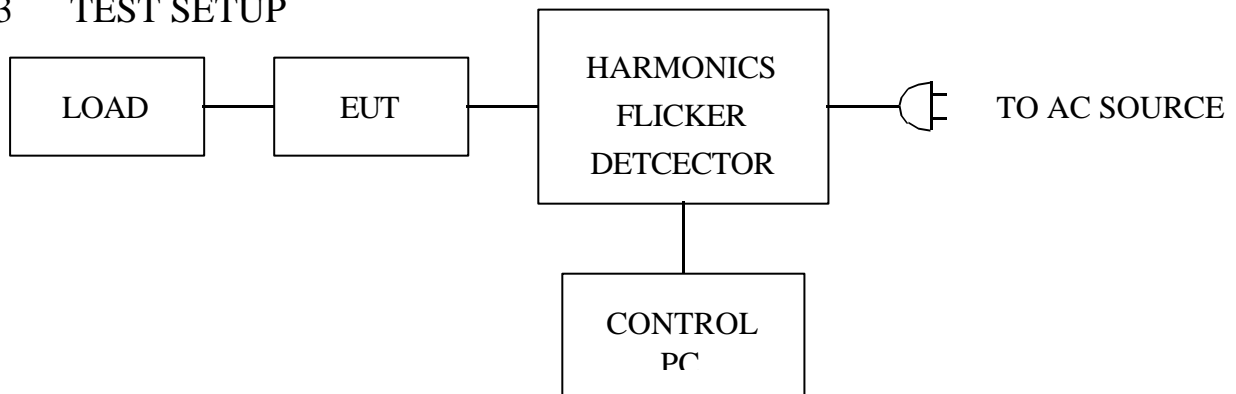

(Details for setup configuration, please refer to appendix A.)

4 CONFIGURATION OF THE EUT

Same as “Conducted Power Line test”, section 4

5 OPERATION CONDITION OF EUT

Same as “Conducted Power Line test”, section 5

6 TEST DATA & LIMIT

6.1 Temperature : 27

6.2 Humidity : 60 % RH

7 Photos of test configuration please refer to appendix A.



EMC PARTNER AG, SWITZERLAND

Date : 2004/12/16 03:39:27 V2.05

File :

Operator : VIC
 Unit : Transmission
 Serialnumber : PCT017
 Remarks : 3L030

Urms = 229.9V Freq = 49.969 Range: 0.25 A
 Irms = 0.035A Ipk = 0.063A cf = 1.804
 P = 4.908W Pap = 7.999VA pf = 0.614

Test - Time : 1 x 15min = 15min (100 %)

LIN (Line Impedance Network) : Soft LIN 0.24 Ohm +j 0.15 Ohm N: 0.16 Ohm +j 0.10 Ohm

Limits : Plt : 0.65 Pst : 1.00
 dmax : 4.00 % dc : 3.00 %
 dtLim: 3.00 % dt>Lim: 200ms

Test completed, Result: PASSED

Plt = 0.072

	Pst	dmax
		[%]
1	0.072	0.000

ELECTROSTATIC DISCHARGE IMMUNITY TEST (ESD)

1 TEST INSTRUMENTS & FACILITIES

Instruments/ Facilities	Manufacturer	Model # Serial #	Data Of Cal.
ESD TESTER	NOISEKEN	ESS-100L (A)	OCT/2004
VCP	HOMETEK	--	--

2 TEST PROCEDURE

According to **IEC 61000-4-2 (2001)**

According to **EN 50130-4 (1996) + A1 (1998)**

3 TEST SETUP

TABLE SIZE

160L X 80W X 80H cm

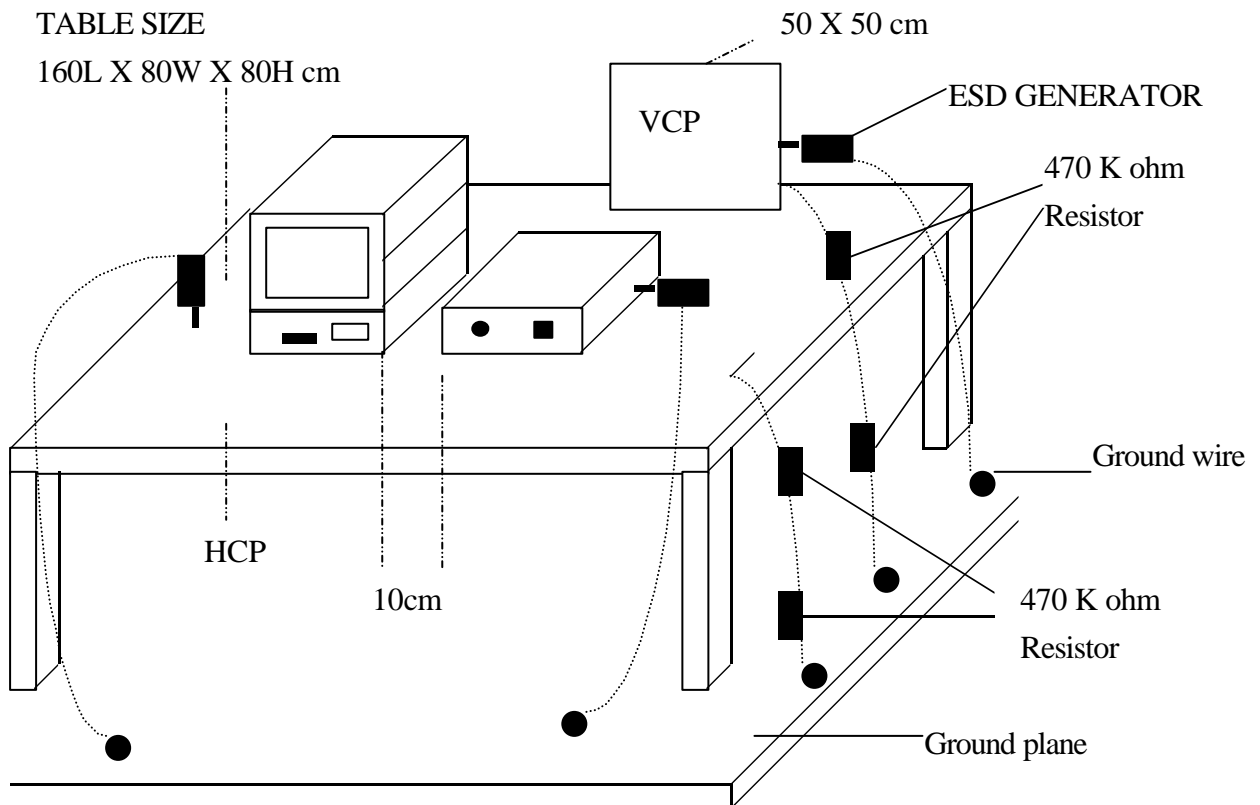

(Details for setup configuration, please refer to appendix A.)



4 CONFIGURATION OF THE EUT

Same as “Conducted Power Line test”, section 4

5 EUT OPERATION CONDITION

Same as “Conducted Power Line test”, section 5

6 TEST CONDITION

6.1 Test Level :

(A) $\pm 2, 4, 8\text{KV}$ for air discharge.

(B) $\pm 2, 4, 6\text{KV}$ for contact discharge.

6.2 Number of test : 10 Discharges / Test point / Polarity / Level

6.3 Time between test : 1 sec.

6.4 Temperature : 26

6.5 Humidity : 54 % RH.

7 PERFORMANCE CRITERIA

There shall be no damage, malfunction or change of status due to the conditioning. Flickering of an indicator during the application of the discharges is permissible, providing that there is no residual change in the EUT or any change in outputs, which could be interpreted by associated equipment as a change.

The EUT shall meet the acceptance criteria for the functional test, after the conditioning.



8 TEST RESULT

Test Point	Air Discharge	Contact Discharge	Result
HCP	---	$\pm 2, 4, 6KV$	PASSED
VCP	---	$\pm 2, 4, 6KV$	PASSED
CASE	$\pm 2, 4, 8KV$	$\pm 2, 4, 6KV$	PASSED
I/O PORTS	$\pm 2, 4, 8KV$	$\pm 2, 4, 6KV$	PASSED
LED	$\pm 2, 4, 8KV$	$\pm 2, 4, 6KV$	PASSED
SCREWS	$\pm 2, 4, 8KV$	$\pm 2, 4, 6KV$	PASSED
DC SOCKET	$\pm 2, 4, 8KV$	$\pm 2, 4, 6KV$	PASSED
BUTTON	$\pm 2, 4, 8KV$	$\pm 2, 4, 6KV$	PASSED

9 Photos of test configuration please refer to appendix A.



RADIO FREQUENCY ELECTROMAGNETIC FIELD IMMUNITY TEST (RS)

1 TEST INSTRUMENTS & FACILITIES

Item	Instruments Facilities	Manufacturer	Model # Serial #	Data Of Cal.
1	SIGNAL GENERATOR	ROHDE & SCHWARZ	SMY02 845181/025	MAR/2004
2	AMPLIFIER	AMPLIFIER RESEARCH	100W1000M1A	N/A
3	FIELD SENSOR	AMPLIFIER RESEARCH	FP2000	AUG/2004
4	FIELD MONITOR	AMPLIFIER RESEARCH	FM2000	AUG/2004
5	RF VOLTMETER	BOONTON	9200C 361701AA	MAR/2004
6	RF PROBE	BOONTON	952001B 37082	MAR/2004
7	DIRECTION COUPLER	AMPLIFIER RESEARCH	DC6180 20521	N/A
8	ANTENNA	EMCO	3142B S/N: 1789	N/A
9	CONTROL PC	KB TECH	KB P586/133	--

Note : Items 3 ~ 4 were calibrated with two years and verified before testing.

2 TEST PROCEDURE

According to **IEC 61000-4-3 (2002)**

According to **EN 50130-4 (1996) + A1 (1998)**

3 TEST SETUP

FERRITE TILE

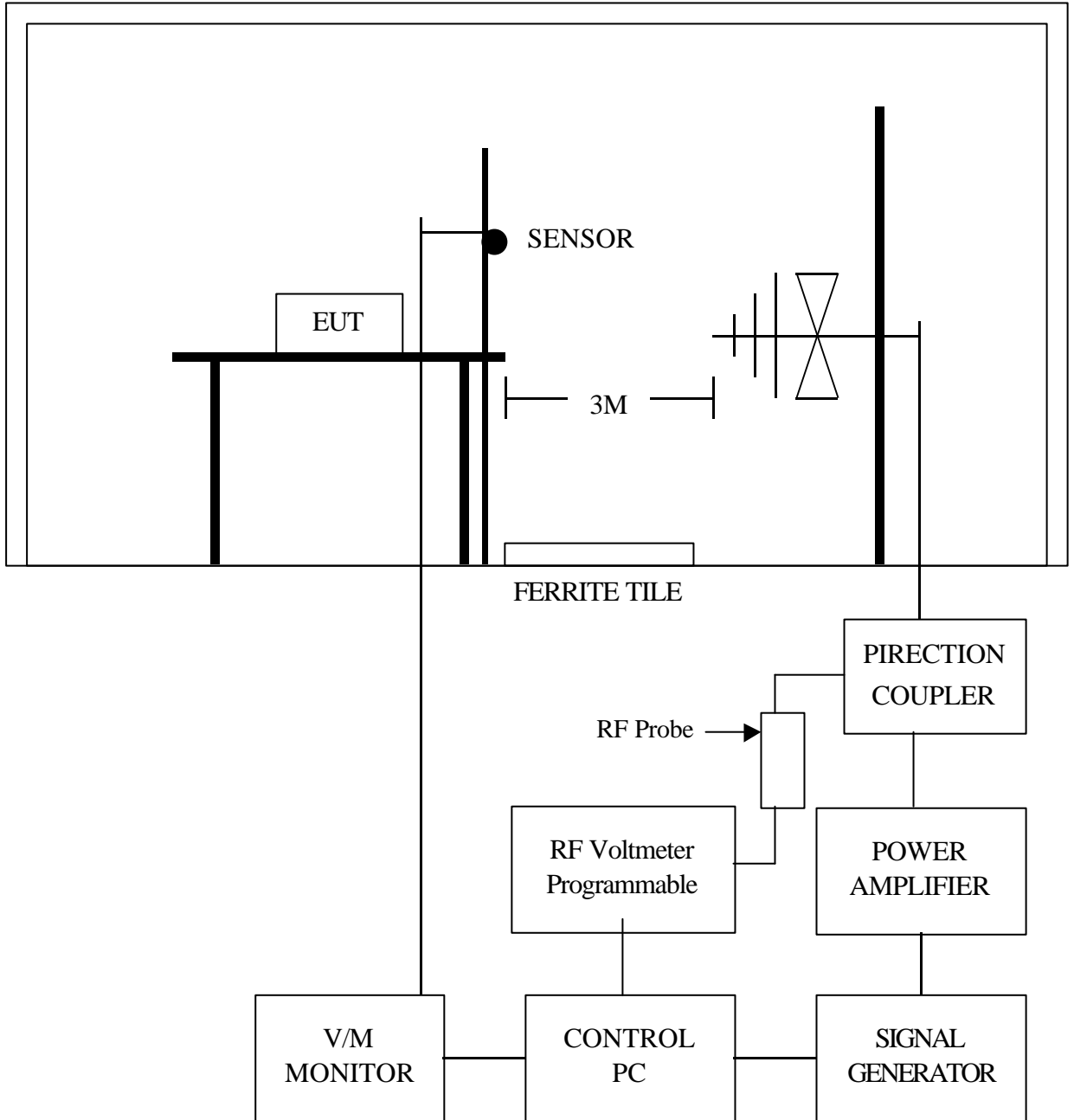

3.1 Chamber Size :

12M x 5M x 5M

(Details for setup configuration, please refer to appendix A.)



4 CONFIGURATION OF THE EUT

Same as “Conducted Power Line test”, section 4

5 OPERATION CONDITION OF EUT

Same as “Conducted Power Line test”, section 5

6 TEST CONDITION

- 6.1 Frequency Range : 80 MHz ~ 1000 MHz
(Frequency Range : 1.4 GHz ~ 2.0 GHz is not applicable for EN50130-4:1996+A1:1998)
- 6.2 Filed Strength : 10 V / M (1KHz 80% Sinusoidal amplitude modulation)
10 V / M (1KHz 0.5s on : 0.5s off pulse modulation)
- 6.3 Frequency Step : 1 %, 3 sec. / each step size
- 6.4 Antenna Polarity : HORIZONTAL & VERTICAL
- 6.5 The four sides of EUT are tested
(FRONT, REAR, RIGHT, LEFT)
- 6.6 Temperature : 27
- 6.7 Humidity : 60 % RH

7 PERFORMANCE CRITERIA

There shall be no damage, malfunction or change of status due to the conditioning. Flickering of an indicator during the conditioning is permissible, providing that there is no residual change in the EUT or any change in outputs, which could be interpreted by associated equipment as a change, and no such flickering of indicators occurs at a field strength of 3 V/m.

For components of CCTV system, where the status is monitored by observing the TV picture, then deterioration of the picture is allowed at 10 V/m, providing :

- a There is no permanent damage or change to the EUT (e.g. no corruption of memory or changes to programmable setting etc.);
- b At 3 V/m, any deterioration of the picture is so minor that the system could still be used;
- c There is no observable deterioration of the picture at 1 V/m.

The EUT shall meet the acceptance criteria for the functional test, after the conditioning.

8 TEST RESULT

ANT SIDE	HORIZONTAL	VERTICAL
FRONT	PASSED	PASSED
REAR	PASSED	PASSED
RIGHT	PASSED	PASSED
LEFT	PASSED	PASSED

9 **Photos of test configuration please refer to appendix A.**

ELECTRICAL FAST TRANSIENT/BURST IMMUNITY TEST (EFT)

1 TEST INSTRUMENTS & FACILITIES

Instruments/ Facilities	Manufacturer	Model # Serial #	Data Of Cal.
BURST-TESTER	HAEFELY	PEFT/JUNIOR	FEB/2004
CONTROL PC	KB TECH	KB P586/133	--

2 TEST PROCEDURE

According to **IEC 61000-4-4 (2004)**

According to **EN 50130-4 (1996) + A1 (1998)**

3 TEST SETUP

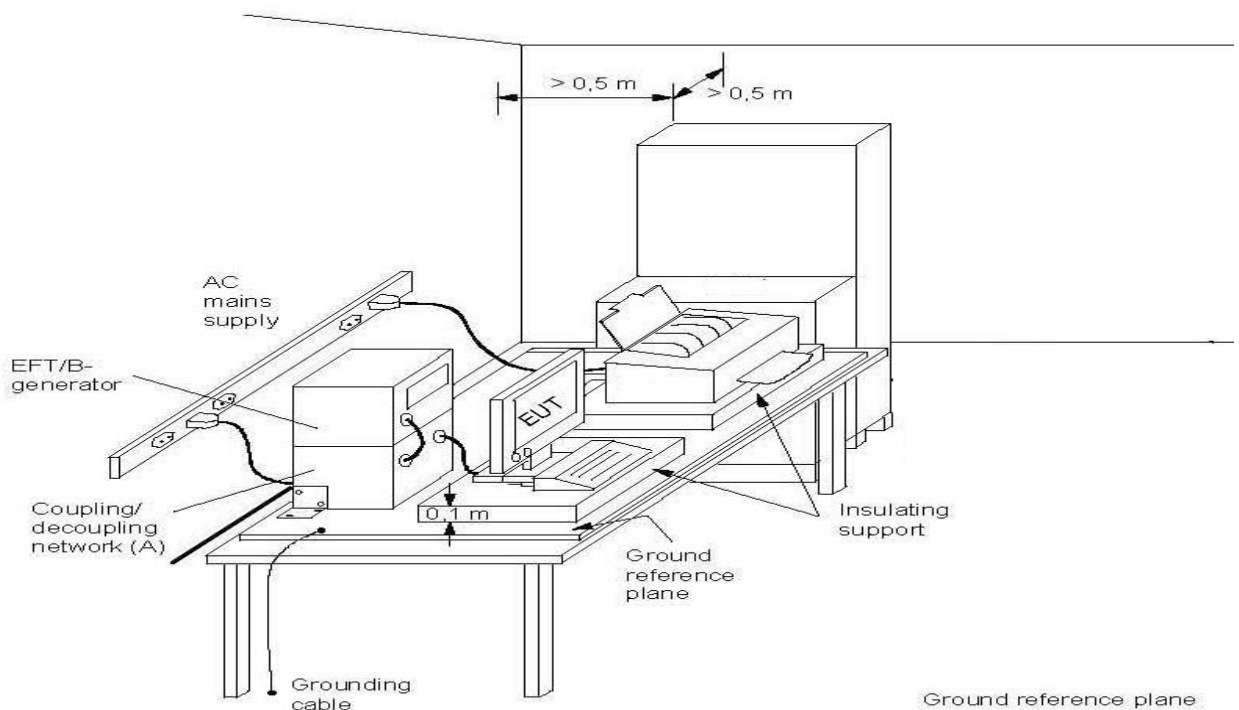

(Details for setup configuration, please refer to appendix A.)

Note: length between clamp and the EUT to be tested (should be $0.5 \text{ m} \pm 0.05 \text{ m}$)

(A) location for supply line coupling

(B) location for signal line coupling



4 CONFIGURATION OF THE EUT

Same as “Conducted Power Line test”, section 4

5 OPERATION CONDITION OF EUT

Same as “Conducted Power Line test”, section 5

6 TEST CONDITION

6.1 Pulse Rise time & Duration : 5 nS / 50 nS

6.2 Pulse Repetition : 5 kHz

6.3 Polarity : POSITIVE / NEGATIVE

6.4 Test Voltage of Power Line : $\pm 0.5KV$, $\pm 1KV$, $\pm 2KV$

6.5 Coupling of power line :
L, N, L+N

6.6 Temperature : 27

6.7 Humidity : 60 % RH

7 PERFORMANCE CRITERIA

There shall be no damage, malfunction or change of status due to the conditioning. Flickering of an indicator during the application of the bursts is permissible, providing that there is no residual change in the EUT or any change in outputs, which could be interpreted by associated equipment as a change.

The EUT shall meet the acceptance criteria for the functional test, after the conditioning.



8 TEST RESULT

Power Line :

TEST VOLTAGE	L	N	L+N
± 0.5KV	✓	✓	✓
± 1KV	✓	✓	✓
± 2KV	✓	✓	✓

8.1 Model : PCT017

8.2 Final Result : PASSED

8.3 Remark :

9 Photos of test configuration please refer to appendix A.

SURGE IMMUNITY TEST

1 TEST INSTRUMENTS & FACILITIES

Instruments/ Facilities	Manufacturer	Model # Serial #	Data Of Cal.
SURGER-TESTER	HAEFELY	PSURGE 4010 583334-38	FEB/2004
ECAT CONTROL CENTER	KeyTek	E-Class Series 100 9502325	OCT/2004
I/O Signal Line Coupler / Decoupler	KeyTek	CM-I / OCD 0103234	--
CONTROL PC	KB TECH	KB P586/133	--

2 TEST PROCEDURE

According To **IEC 61000-4-5 (2001)**

According To **EN 50130-4 (1996) + A1 (1998)**

3 TEST SETUP

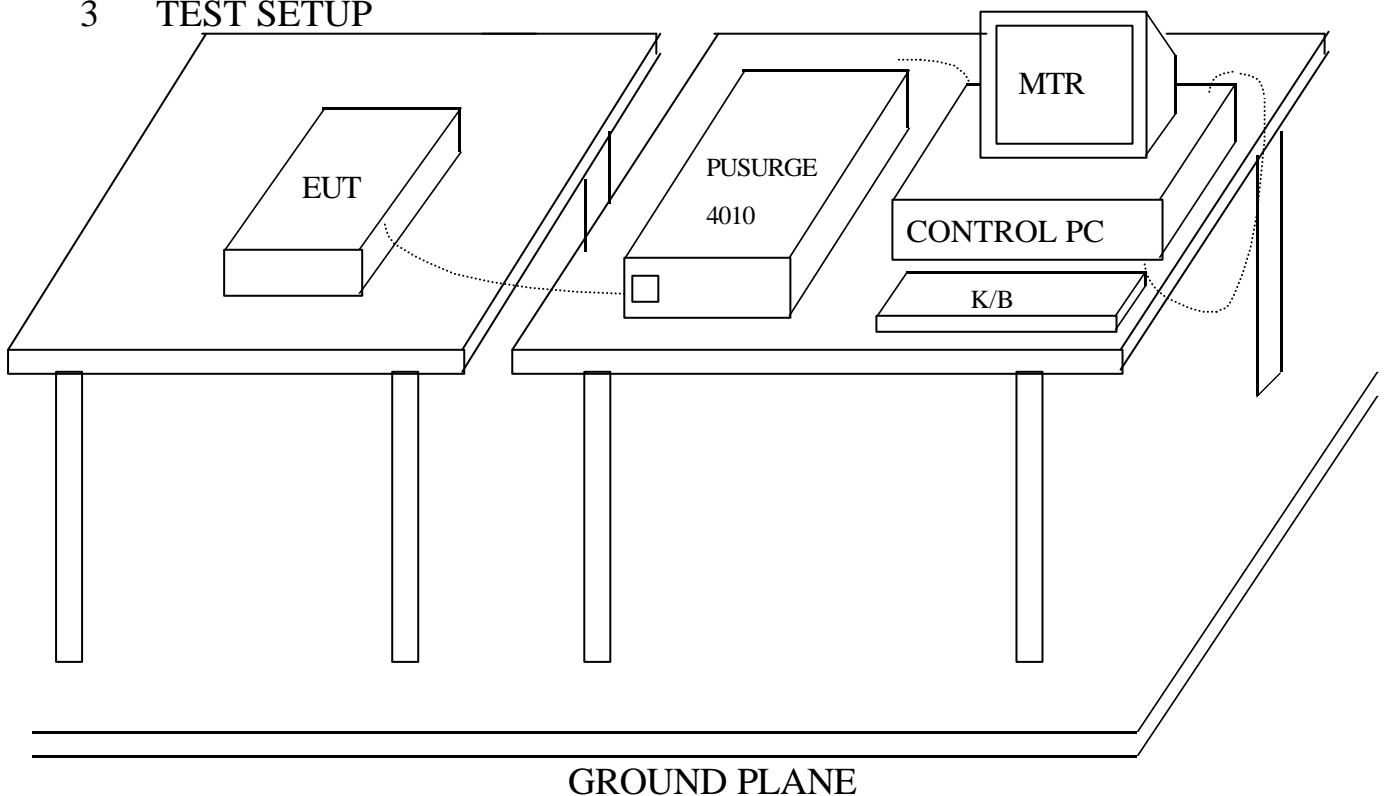

(Details for setup configuration, please refer to appendix A.)

4 TEST LEVELS

- Input and Output AC Power Ports.
- DC Input and DC Output Power Ports.

Environmental Phenomena	Test Specification		Units
	AC	DC	
Test voltage ¹⁾ :			
a.c. mains supply lines:			
Line to Line	± 0.5, 1	N/A	KV (Charge Voltage)
Line to ground ²⁾	± 0.5, 1, 2	N/A	KV (Charge Voltage)
other supply / signal lines: ³⁾			
Line to ground ⁴⁾	N/A	± 0.5, 1	KV (Charge Voltage)
Polarity	+ and -		
Minimum number of surges at each polarity, voltage, coupling mode and line:			
a.c. mains supply lines	20 ⁵⁾		
Other supply / signal lines	5		
<p>1) The test voltages specified are the open-circuit voltages. The test voltages for the lower severity levels are included, because all the lower severity levels must also be satisfied.</p> <p>2) Via a 10 series resistor.</p> <p>3) No test is required where the manufacturer's specification indicates that it is not permitted to connect cables >30m long.</p> <p>4) Via a 40 series resistor.</p> <p>5) Five at each zero-crossing point and at the maximum and minimum points on the mains voltage wave.</p>			

5 CONFIGURATION OF THE EUT

Same as "Conducted Power Line test", section 4

6 EUT OPERATION CONDITION

Same as "Conducted Power Line test", section 5



7 CONDITIONS DURING TESTING

7.1 Coupling of power line :

(A) Line to Line $\pm 0.5KV, \pm 1KV$ (AC)

(B) Line to Ground $\pm 0.5KV, \pm 1KV$ (AC)

7.2 Test Voltage of Signal Control Line : $\pm 0.5KV, \pm 1KV$

7.2 Polarity : POSITIVE / NEGATIVE

7.3 Phase shifting in a range between 0° to 360°

7.4 Repetition rate at least 1 per min

7.5 Test times on ac mains supply lines :

5 at each zero-crossing point and at the maximum and minimum point on the mains voltage wave.

7.6 Test times on signal lines : 5

7.7 Temperature : 27 (15 ~ 35)

Humidity : 60 % RH.(10 % ~ 75%)

8 PERFORMANCE CRITERIA

There shall be no damage, malfunction or change of status due to the conditioning. Flickering of an indicator during the application of the surges is permissible, providing that there is no residual change in the EUT or any change in outputs, which could be interpreted by associated equipment as a change.

The EUT shall meet the acceptance criteria for the functional test, after the conditioning.



9 TEST RESULT

Power Line :

Environmental Phenomena	Test Specification	Units
Line to Line	$\pm 0.5, 1$	KV (Charge Voltage)

Signal Control Line :

Environmental Phenomena	TEST VOLTAGE	Units
Video Output	$\pm 0.5, 1$	KV (Charge Voltage)

9.1 Model : PCT017

9.2 Final Result : PASSED

9.3 Remark :

10 Photos of test configuration please refer to appendix A.



IMMUNITY TEST TO CS CONDUCTED DISTURBANCE

1 TEST INSTRUMENTS & FACILITIES

Instruments/ Facilities	Manufacturer	Model # Serial #	Date Of Cal.
SIGNAL GENERATOR	ROHDE & SCHWARZ	SMY02 845181/025	MAR/2004
SIGNAL GENERATOR	Agilent	8648C 4108A05773	SEP/2004
AMPLIFIER	AMPLIFIER RESEARCH	75A250 25680	N/A
AMPLIFIER (75Watts 10KHz-250MHz)	AMPLIFIER RESEARCH	75A250AM1 306334	N/A
RF VOLTMETER	BOONTON	9200C 361701AA	MAR/2004
RF PROBE	BOONTON	952001B 37082	MAR/2004
DIRECTION COUPLER	AMPLIFIER RESEARCH	DC2600 20508	N/A
COUPLING DECOUPLING NETWORK	FCC	FCC-801-M3-25A 9993	FEB/2004
POWER METER	Boonton	4232A-01-02 98601	SEP/2004
POWER SENSOR	Boonton	51011-EMC 32862	SEP/2004
POWER SENSOR	Boonton	51011-EMC 32864	FEB/2004
EM Injection Clamp	Fischer Custom Communications, Inc.	F-203I-23mm 421	FEB/2004
CONTROL PC	KB TECH	KB P586/133	--

2 TEST PROCEDURE

According To **ENV 50141 (1993)**

According To **EN 50130-4 (1996) + A1 (1998)**



4 TEST LEVELS

- Ports for signal lines and control lines.
- DC input and DC output power ports.
- Input and Output AC Power Ports.
- Functional earth Ports.

Environmental	Test Specification	Units
Radio-frequency	0.15 - 100	MHz
Common mode	10	V
Amplitude Modulation	80	% (1KHz)
Pulse Modulation	1	Hz (0.5s on : 0.5s off)

5 CONFIGURATION OF THE EUT

Same as “Conducted Power Line test”, section 4

6 EUT OPERATION CONDITION

Same as “Conducted Power Line test”, section 5

7 CONDITIONS DURING TESTING

7.1 The EUT tested type :

- Single unit
- Multiple unit

7.2 Dwell time : < 3 Seconds

7.3 Step size : < 1%

7.4 Test times : 3 times (pulse modulation)

7.5 Temperature : 27 (15 ~ 35)

Humidity : 60 % RH.(10 % ~ 75%)



8 PERFORMANCE CRITERIA

There shall be no damage, malfunction or change of status due to the conditioning. Flickering of an indicator during the conditioning is permissible, providing that there is no residual change in the EUT or any change in outputs, which could be interpreted by associated equipment as a change, and no such flickering of the picture is allowed at 10V, providing :

- a There is no permanent damage or change to the EUT (e.g. no corruption of memory or changes to programmable settings etc.);
- b At $U_0 = 3V$, any deterioration of the picture is so minor that the system could still be used;
- c There is no observable deterioration of the picture at $U_0 = 1V$.

The EUT shall meet the acceptance criteria for the functional test, after the conditioning.

9 TEST RESULT

TEST Specification	Unit
0.15 - 100	MHz
10	V
80	% (1KHz)
1	Hz (0.5s on : 0.5s off)

9.1 Model : PCT017

9.2 Final Result : PASSED

9.3 Remark :

10 Photos of test configuration please refer to appendix A.

VOLTAGE DIPS, SHORT INTERRUPTIONS IMMUNITY TEST AND MAIN SUPPLY VARIATIONS

1 TEST INSTRUMENTS & FACILITIES

Instruments/ Facilities	Manufacturer	Model # Serial #	Data Of Cal.
LINE INTERFERENCE -TESTER	HAEFELY	PLINE 1610 080166-10	MAR/2004
CONTROL PC	KB TECH	KB P586/133	--
FREQUENCY CONVERTER	EXTECH	CFC-130	--
DIGITAL MULTIMETER	ESCORT	EDM-88 30802175	JUL/2004

2 TEST PROCEDURE

According To **IEC 61000-4-11 (2004)**

According To **EN 50130-4 (1996) + A1 (1998)**

3 TEST SETUP

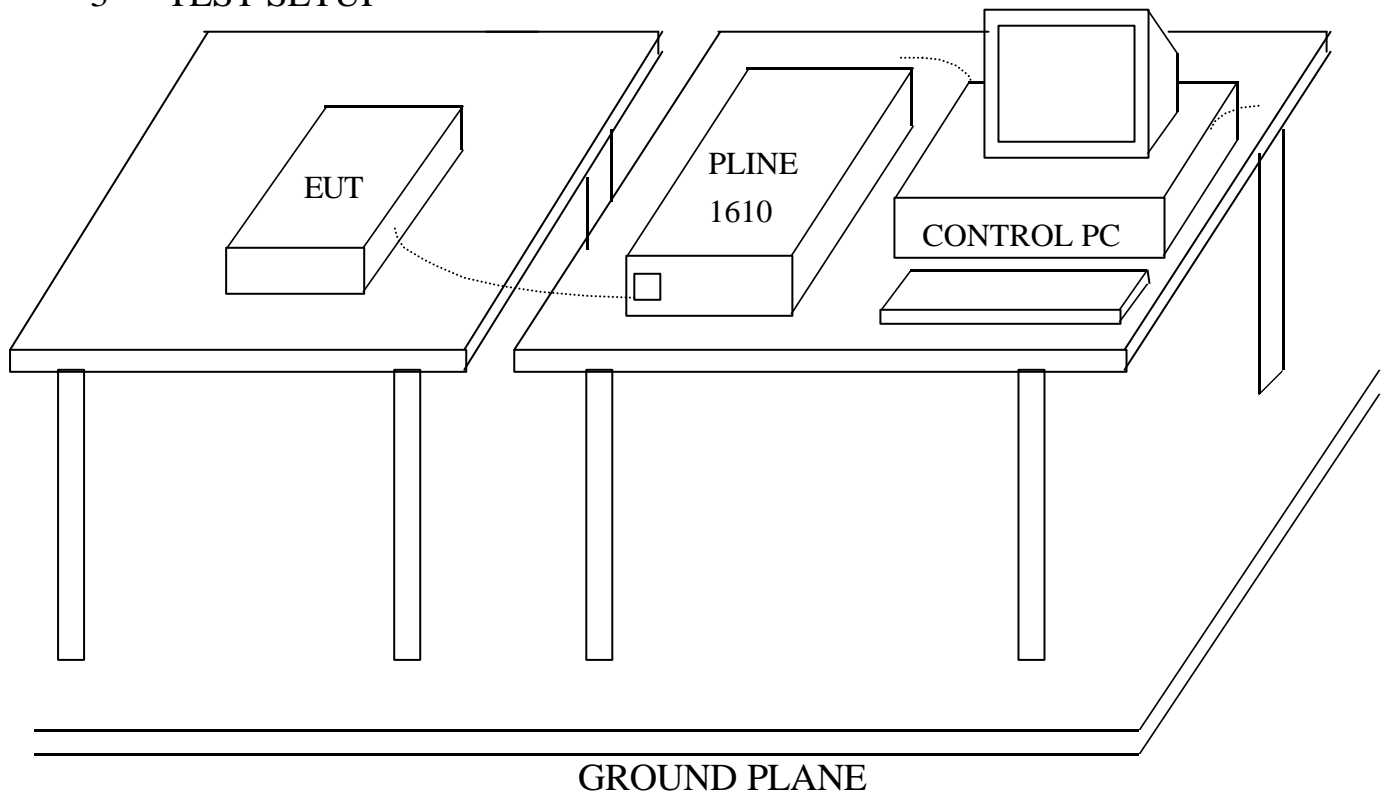



4 TEST LEVELS FOR DIPS

Input and Output AC Power Ports.

- Voltage Dips.
- Voltage Interruptions.

Environmental Phenomena	Test Specification	Units
Voltage Dips	60 0.5, 1, 5, 10	% Reduction periods
	100 0.5, 1, 5	% Reduction periods
Interval between reductions	10	Second
Number of reduction at each duration	3 (Voltage Dip 60) 3 (Voltage Dip 100)	Times

5 CONFIGURATION OF THE EUT

Same as “Conducted Power Line test”, section 4

6 EUT OPERATION CONDITION

Same as “Conducted Power Line test”, section 5

7 CONDITIONS DURING TESTING

7.1 Temperature : 27 (15 ~ 35)

Humidity : 60 % RH.(25 % ~ 75%)



8 PERFORMANCE CRITERIA

There shall be no damage, malfunction or change of status due to the conditioning. Flickering of an indicator during the conditioning is permissible, providing that there is no residual change in the EUT or any change in outputs, which could be interpreted by associated equipment as a change.

The EUT shall meet the acceptance criteria for the functional test, after the conditioning.

9 TEST RESULT

Same as “Voltage Dips, Short Interruptions Immunity Test and Main Supply Variations”, section 4

9.1 Model : PCT017

9.2 Final Results : PASSED

9.3 Remark



10 TEST LEVELS FOR MAIN SUPPLY VARIATIONS

Extreme Voltages		Voltage Applied	Perform Criteria
Supply voltage max (Umax)	Unom + 10%	253.0V	A
Supply voltage min (Umin)	Unom – 15%	195.5V	A

11 PERFORMANCE CRITERIA

- A. The apparatus or system shall continue to operate as intended while performs testing. No degradation of performance or loss of function is allowed below. No degradation or influence for display picture.
- B. The apparatus or system might have influence from electrical interference while testing, however there is normal operation after turn off electrical interference. It is allowance that is following phenomenon that is appeared while turn on the elector interference.
- C. The apparatus or system lost or temporary lost the function while performs the testing, it shall operate normally after turn off the elector interference or reset the apparatus main power.

12 TEST RESULT

Same as “Voltage Dips, Short Interruptions Immunity Test and Main Supply Variations”, section 10

12.1 Model : PCT017

12.2 Final Results : PASSED

12.3 Remark

13 Photos of test configuration please refer to appendix A.



HomeTek Technology Inc.

Appendix A

PHOTOS OF TEST CONFIGURATION



HomeTek Technology Inc.

PHOTO OF CONDUCTED POWER LINE TEST

Model: PCT017



Front View



Rear View

PHOTO OF RADIATED EMISSION TEST

Model: PCT017

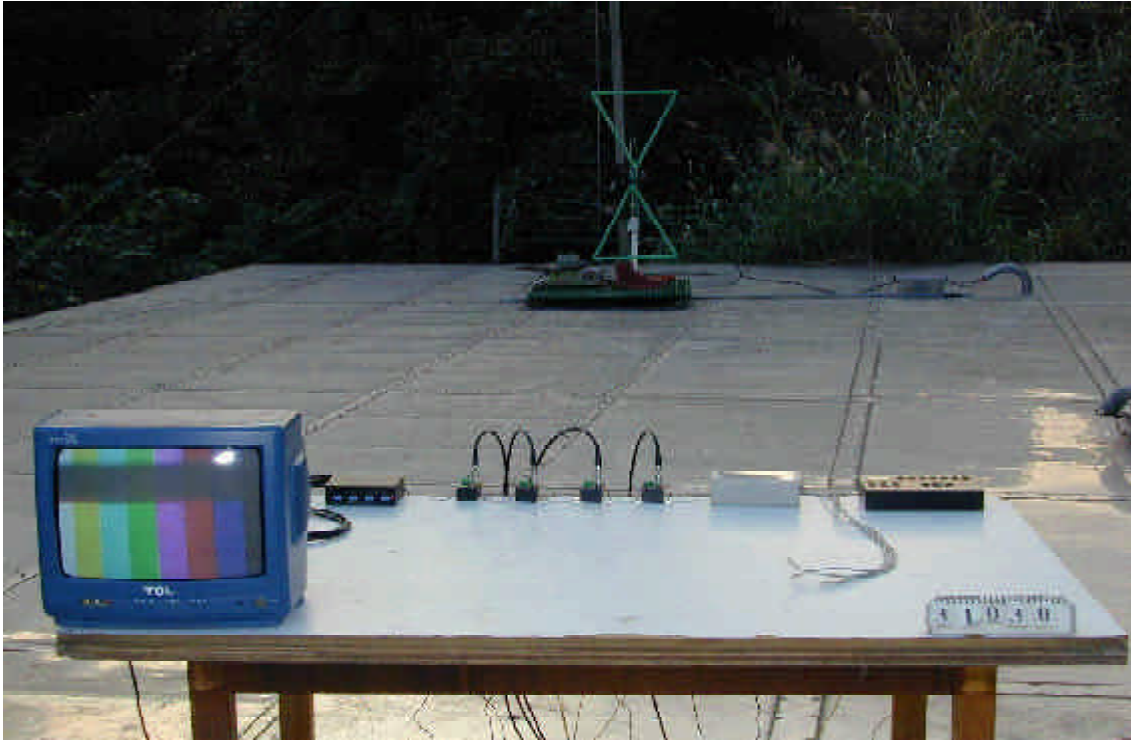

Front View



Rear View



**PHOTO OF HARMONICS & VOLTAGE FLUCTUATIONS TEST
AND SURGE IMMUNITY TEST AND VOLTAGE DIPS, SHORT
INTERRUPTIONS IMMUNITY TEST**

Model : PCT017



**PHOTO OF ELECTRICAL FAST TRANSIENT/BURST IMMUNITY
TEST**



EB3L030



HomeTek Technology Inc.

PHOTO OF ELECTROSTATIC DISCHARGE IMMUNITY TEST (ESD)

Model: PCT017



**PHOTO OF RADIO FREQUENCY ELECTROMAGNETIC FILE
IMMUNITY TEST (RS)**

Model: PCT017

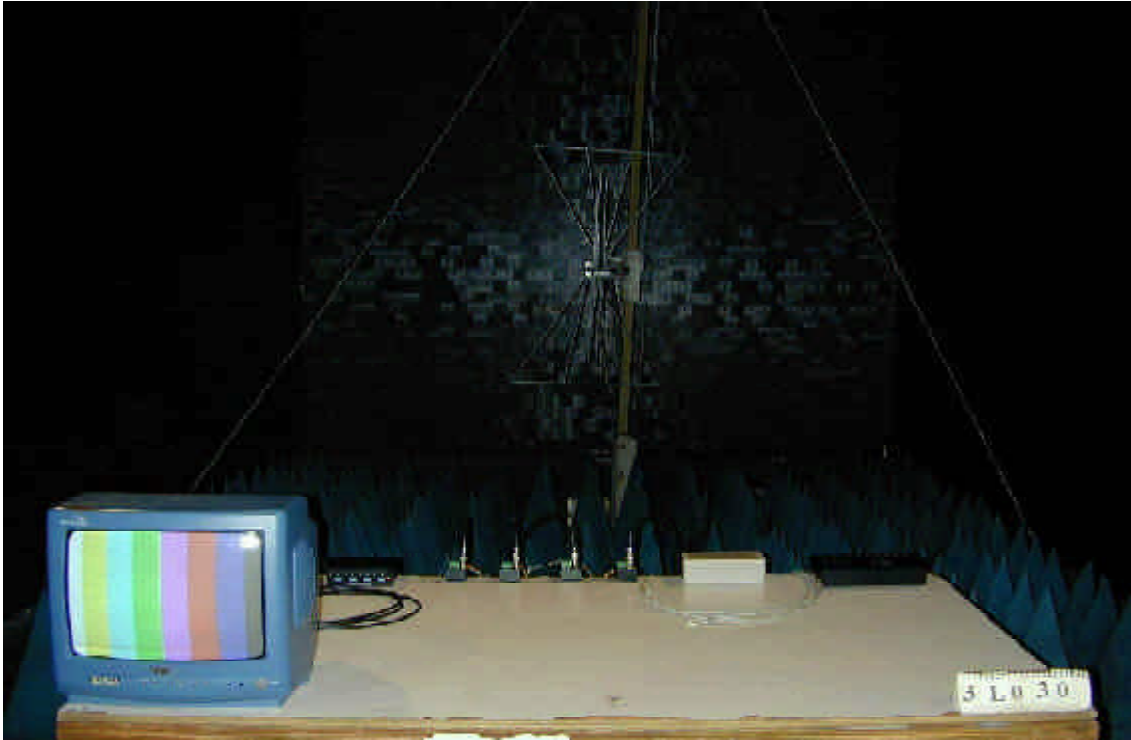
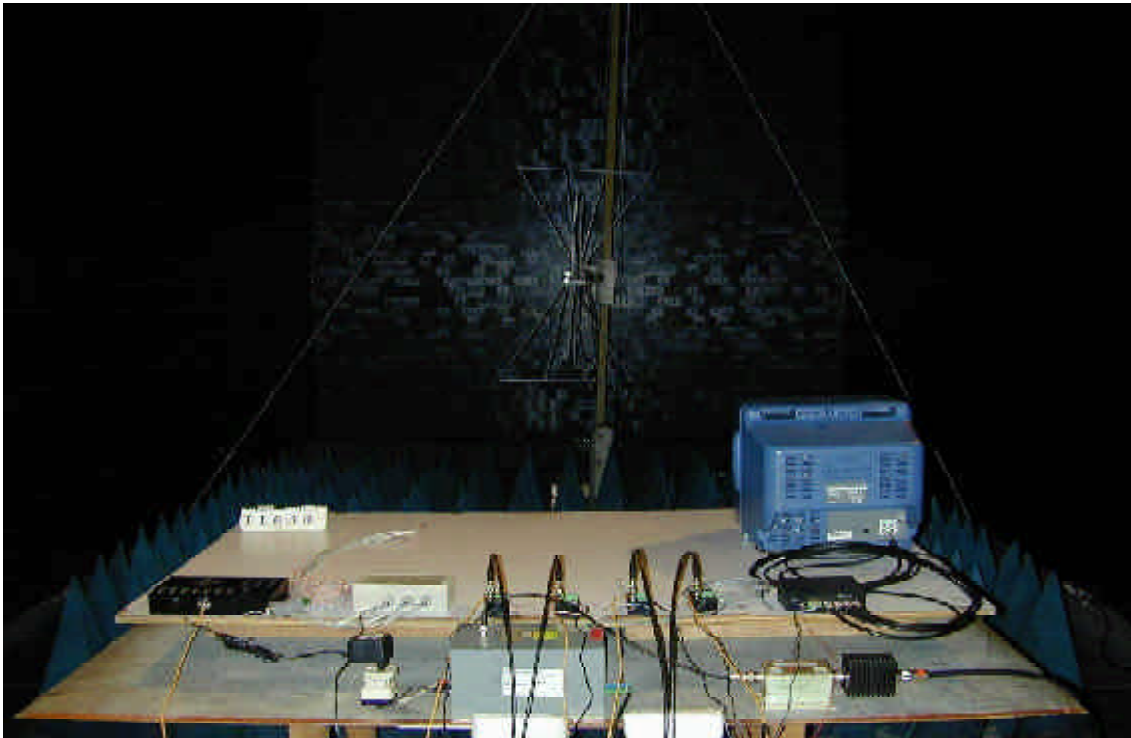

PHOTO OF CS CONDUCTED DISTURBANCE IMMUNITY TEST





HomeTek Technology Inc.

Appendix B

PHOTOS OF EUT

PHOTO OF EUT

Model : PCT017

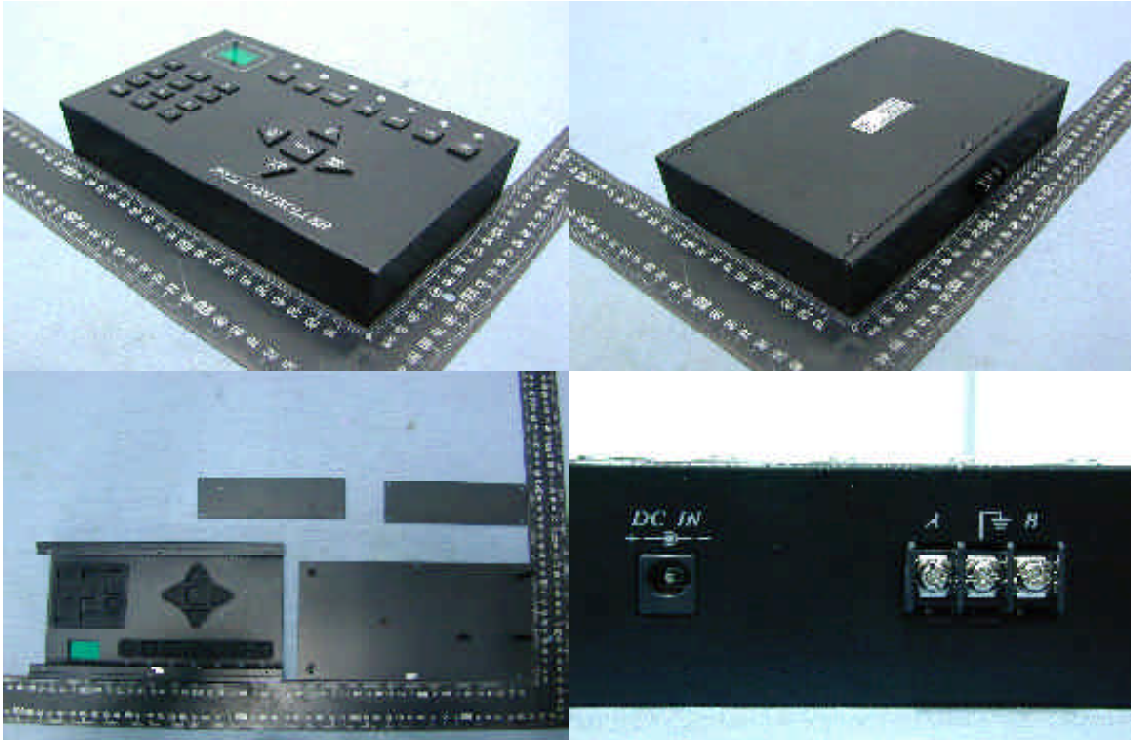

Full View of EUT

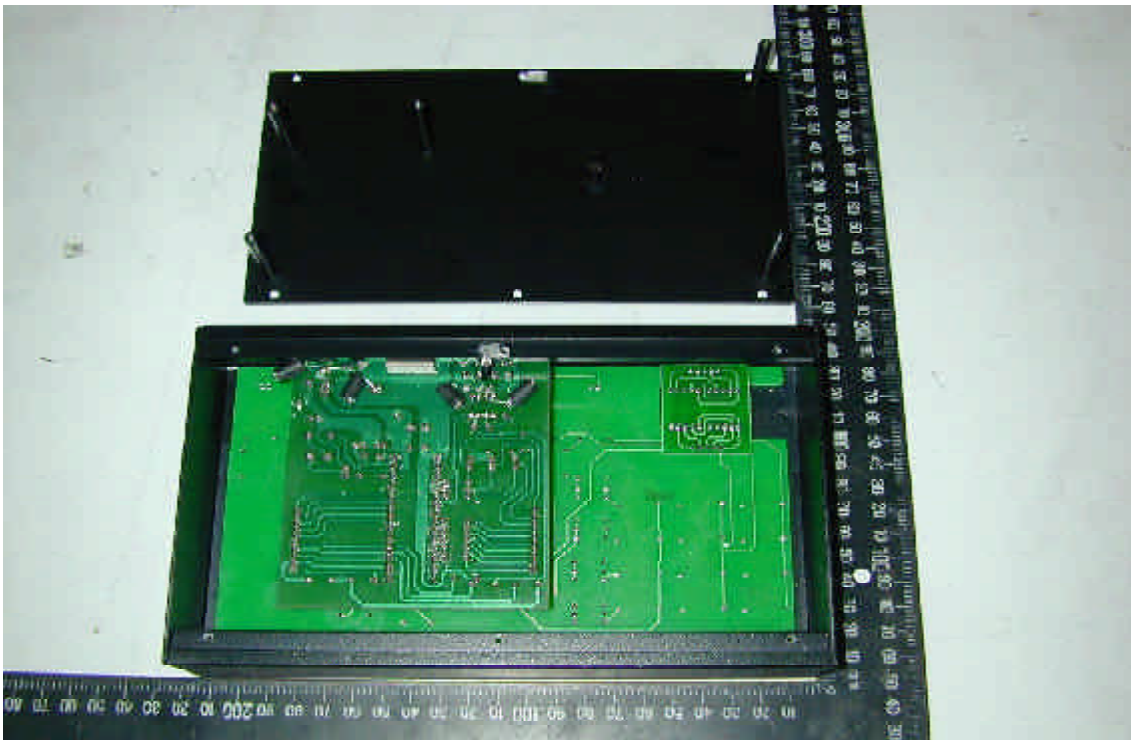

Inside View of EUT

PHOTO OF EUT

Model : PCT017

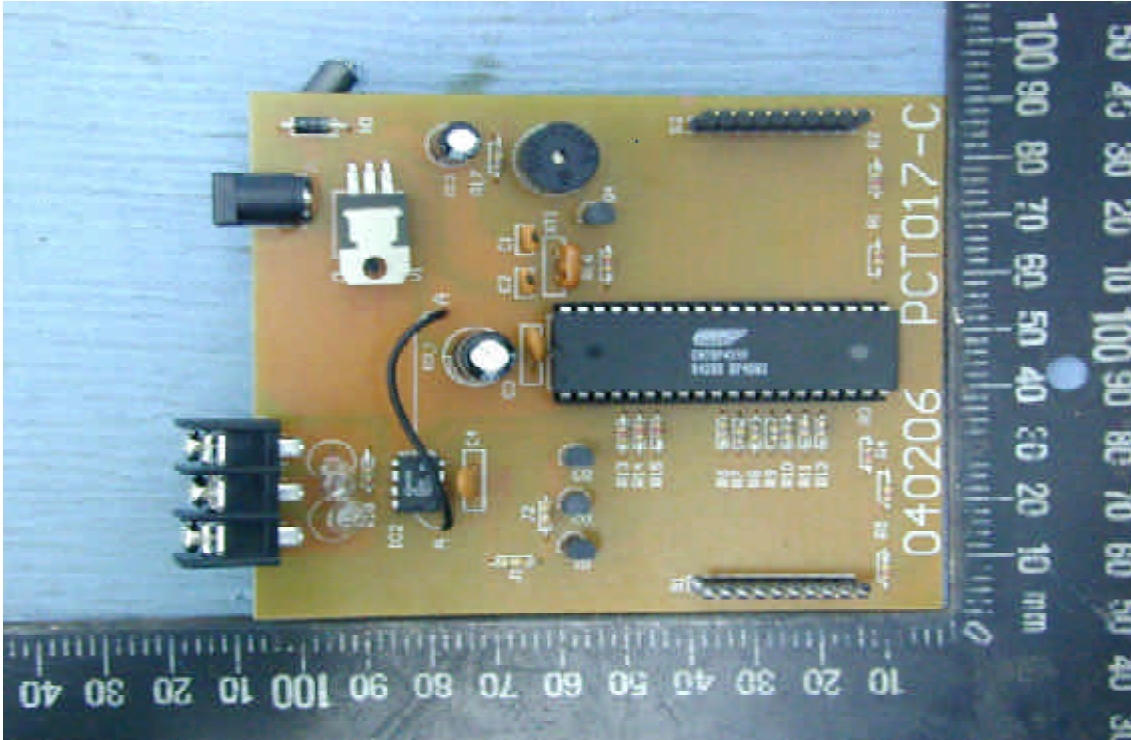

Component Side of Main Board - 1

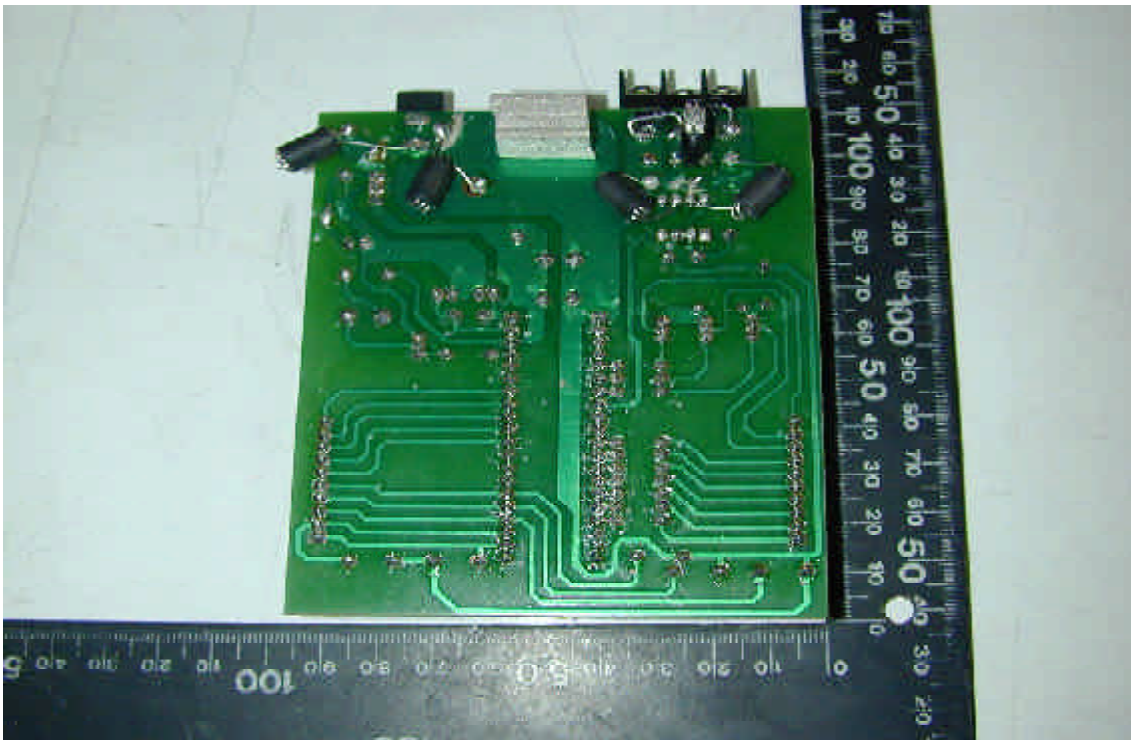

Solder Side of Main Board - 1

PHOTO OF EUT

Model : PCT017

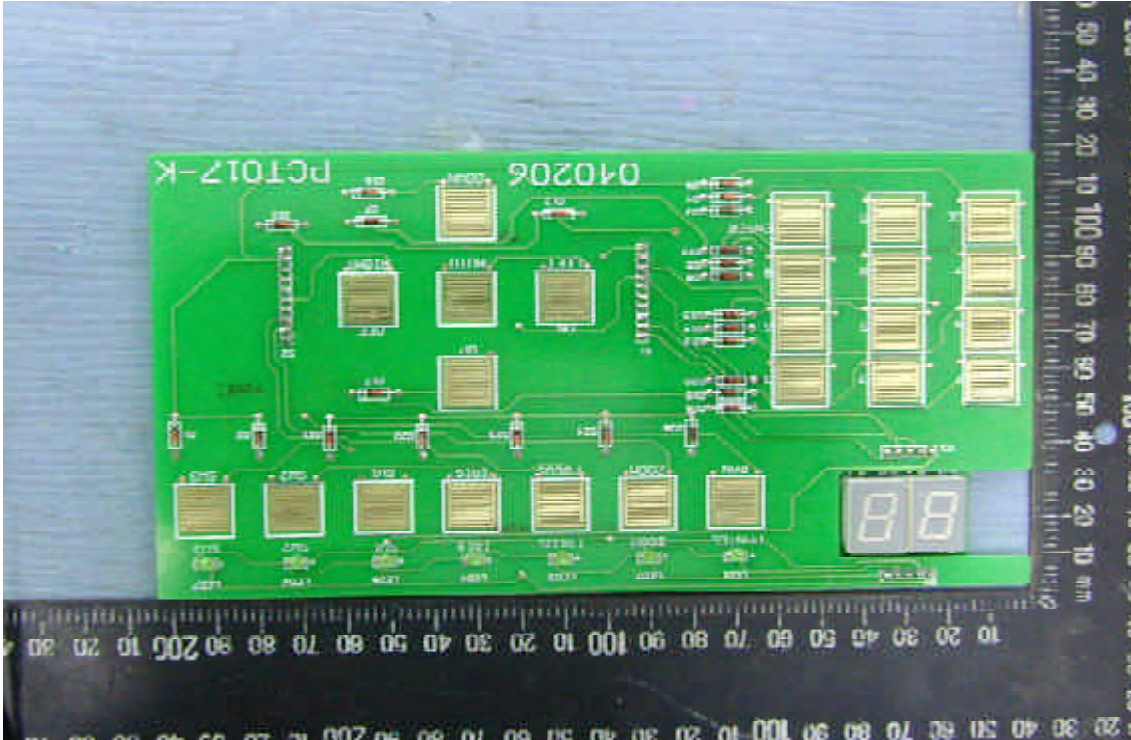

Component Side of Main Board - 2

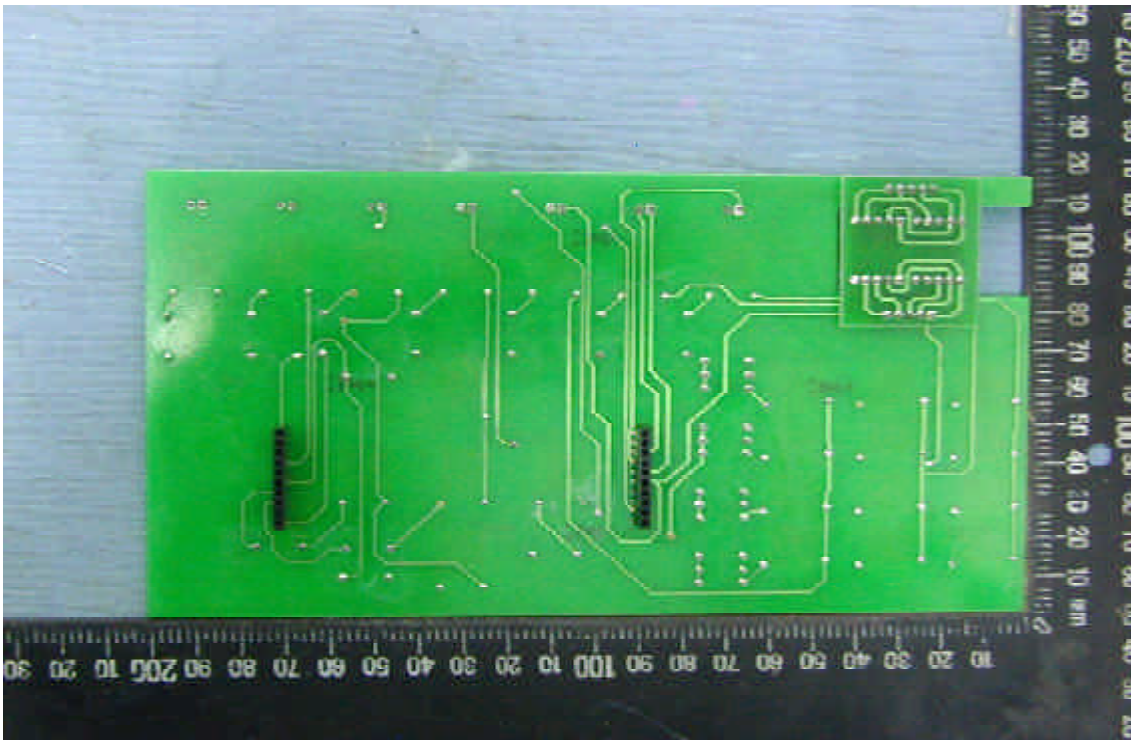

Solder Side of Main Board - 2

PHOTO OF EUT

Model : PCT0XX



Front View of Adaptor



Rear View of Adaptor

Declaration of Conformity

We(Manufacturer/Importer)

(company name)

(address)

declares under our sole responsibility that the product

Product name : Transmission

Model No. : PCT0XX

to which this declaration relates is in conformity with the following standard(s) or other normative document(s)

- | | |
|---|--|
| <input checked="" type="checkbox"/> EN 61000-6-3 (2001) | <input checked="" type="checkbox"/> EN 50130-4 (1996)
+ A1 (1998) |
| <input checked="" type="checkbox"/> CISPR 22 Class B (1997) | <input checked="" type="checkbox"/> IEC 61000-4-2 (2001) |
| <input checked="" type="checkbox"/> EN 61000-3-2 (2000) | <input checked="" type="checkbox"/> IEC 61000-4-3 (2002) |
| <input checked="" type="checkbox"/> EN 61000-3-3 (1995) | <input checked="" type="checkbox"/> IEC 61000-4-4 (2004) |
| + A1 (2001) | <input checked="" type="checkbox"/> IEC 61000-4-5 (2001) |
| | <input checked="" type="checkbox"/> ENV 50141 (1993) |
| | <input checked="" type="checkbox"/> IEC 61000-4-11 (2004) |

following the provisions of 89/336/EEC Directive

Place: _____ Signature: _____

Date : _____ Full name: _____



Title: _____

TÜV Rheinland Taiwan Ltd.



Certificate of Appointment

for the applicant:

Hometek Technology Inc.
No. 67-9, Shir Men Rd., Tu-Cheng City,
Taipei Hsien 236, Taiwan, R.O.C.

has been authorized to carry out EMC tests by order and under supervision of TÜV Rheinland. It has successfully demonstrated capability to conduct measurement and to process test data according to:

**European and International EMC Standards as listed in the
Scope of Authorization on the attachment to this certificate**

An assessment of the facility was conducted by TÜV Rheinland auditors according to the TÜV Rheinland requirements for "Test Site Approval" with reference to

ISO 17 025:1999

Certificate No. : 10012161-2004

Valid until : February 14, 2006

TÜV Rheinland Taiwan Ltd.
Taipei, December 21, 2004

Dipl.-Ing. Andreas Klinker
Certification Body

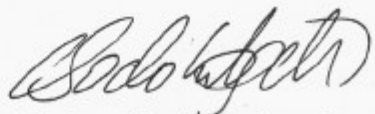
Dipl.-Ing. Bodo Kretzschmar
Product Safety and Quality



Attachment to
Certificate
of Appointment

SCOPE OF AUTHORIZATION

Hometek Technology Inc.
No. 67-9, Shir Men Rd., Tu-Cheng City,
Taipei Hsien 236, Taiwan, R.O.C.

European Standards

EN 50081-1	EN 61000-3-2	ENV 50140
EN 50081-2	EN 61000-3-3	ENV 50141
EN 50082-1	EN 61000-6-1	ENV 50204
EN 50130-4	EN 61000-6-2	
EN 50091-2	EN 61000-6-3	
EN 55011	EN 61000-6-4	
EN 55013	EN 61000-3-11	
EN 55014-1	EN 61000-4-2	
EN 55014-2	EN 61000-4-3	
EN 55022	EN 61000-4-4	
EN 55024	EN 61000-4-5	
EN 60601-1-2	EN 61000-4-6	
EN 60801	EN 61000-4-8	
EN 60945	EN 61000-4-11	
	EN 61204-3	

International Standards

CISPR 11	IEC 61000-4-2	IEC 61000-3-2
CISPR 13	IEC 61000-4-3	IEC 61000-3-3
CISPR 14-1	IEC 61000-4-4	IEC 61000-3-11
CISPR 14-2	IEC 61000-4-5	IEC 61000-6-1
CISPR 22	IEC 61000-4-6	IEC 61000-6-2
CISPR 24	IEC 61000-4-8	IEC 61000-6-3
	IEC 61000-4-11	IEC 61000-6-4
IEC 801.2	IEC 61000-4-12	IEC 60945
IEC 801.3		
IEC 801.4		

Certificate No. : 10012161-2004

Taipei, December 21 , 2004

Dipl.-Ing. Bodo Krätzschar
Product Safety and Quality