



HomeTek Technology Inc.

ADDRESS: No. 67-9, Shir Men Road, Tu Cheng City,  
Taipei Hsien, Taiwan, R. O. C.

PHONE : 886-2-22608375 FAX : 886-2-22748013

E - mail : hometek@ms15.hinet.net

## CERTIFICATE OF COMPLIANCE

EUT : Power Distributor BOX  
MODEL NO. : PD00XXX  
Receipt Date : 01/12/2005 Final Test Date: 01/26/2005  
REPORT # : EB4A026  
APPLICANT : SMART CABLING & TRANSMISSION CORP.  
ADDRESS : 7F-1, No. 168, Lien Cheng Rd.,  
Chung-Ho City, Taipei Hsien, Taiwan, R. O. C.

Measurement procedure used:

**EMI: EN 61000-6-3 (2001): CISPR 22 Class B (1997),**

**EN 61000-3-2 (2000), EN 61000-3-3 (1995) + A1 (2001)**

**EMS: EN 61000-6-1 (2001):**

**IEC 61000-4-2 (2001), IEC 61000-4-3 (2002), IEC 61000-4-4 (2004), IEC 61000-4-5 (2001),  
IEC 61000-4-6 (2003) + A1 (2004), IEC 61000-4-8 (2001), IEC 61000-4-11 (2004)**

We hereby show that:

The measurements shown in this test report were made in accordance with the procedures given in **EUROPEAN COUNCIL DIRECTIVE 89/336/EEC**, and the energy emitted by the equipment was found to be within the limits applicable.

This test result of this report applies to above tested sample only.

This test report shall not be reproduce in part without written approval of HomeTek Technology Inc.

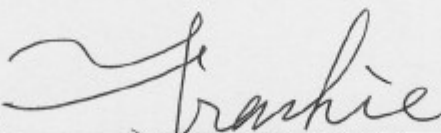
PREPARED BY :  DATE : 1/31/2005  
FRANKIE WANG

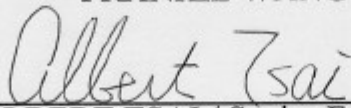
CHECK BY :  DATE : 2/1/2005  
ALBERT TSAI / Senior Engineer

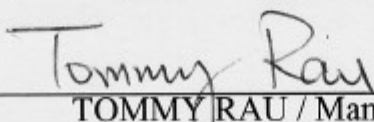
APPROVED BY :  DATE : 2/2/2005  
TOMMY RAU / Manager

EB4A026



**TABLE OF CONTENTS**

**GENERAL INFORMATION.....4**

**MODIFICATION LIST.....6**

**CONDUCTED POWER LINE TEST.....7**

1 TEST PROCEDURE.....7

2 RESULT OF CONDUCTED EMISSION TEST.....7

**RADIATED EMISSION TEST.....8**

1 TEST INSTRUMENTS & FACILITIES .....8

2 TEST PROCEDURE.....9

3 TEST SETUP .....9

4 CONFIGURATION OF THE EUT.....10

5 EUT OPERATING CONDITION.....13

6 LIMIT OF RADIATED EMISSION CLASS B.....13

7 RESULT OF RADIATED EMISSION TEST.....13

8 RADIATED EMISSION TEST DATA (PAGE 1).....14

9 RADIATED EMISSION TEST DATA (PAGE 2).....15

**HARMONICS TEST.....16**

1 TEST PROCEDURE.....16

2 RESULT OF HARMONICS TEST.....16

**VOLTAGE FLUCTUATIONS TEST.....17**

1 TEST PROCEDURE.....17

2 RESULT OF VOLTAGE FLUCTUATIONS TEST .....17

**ELECTROSTATIC DISCHARGE IMMUNITY TEST (ESD).....18**

1 TEST INSTRUMENTS & FACILITIES .....18

2 TEST PROCEDURE.....18

3 TEST SETUP .....18

4 CONFIGURATION OF THE EUT.....19

5 EUT OPERATION CONDITION.....19

6 TEST CONDITION .....19

7 PERFORMANCE CRITERIA .....19

8 TEST RESULT.....20

**RADIO FREQUENCY ELECTROMAGNETIC FIELD IMMUNITY TEST (RF).....21**

1 TEST INSTRUMENTS & FACILITIES .....21

2 TEST PROCEDURE.....21

3 TEST SETUP .....22

4 CONFIGURATION OF THE EUT.....23

5 OPERATION CONDITION OF EUT .....23

6 TEST CONDITION .....23



7 PERFORMANCE CRITERIA .....23

8 TEST RESULT.....24

**ELECTRICAL FAST TRANSIENT/BURST IMMUNITY TEST (EFT) .....25**

1 TEST INSTRUMENTS & FACILITIES .....25

2 TEST PROCEDURE.....25

3 TEST SETUP .....25

4 CONFIGURATION OF THE EUT.....26

5 OPERATION CONDITION OF EUT .....26

6 TEST CONDITION .....26

7 PERFORMANCE CRITERIA .....26

8 TEST RESULT.....27

**SURGE IMMUNITY TEST.....28**

1 TEST INSTRUMENTS & FACILITIES .....28

2 TEST PROCEDURE.....28

3 TEST SETUP .....28

4 TEST LEVELS.....29

5 CONFIGURATION OF THE EUT.....29

6 EUT OPERATION CONDITION.....29

7 CONDITIONS DURING TESTING.....29

8 PERFORMANCE CRITERIA .....30

9 TEST RESULT.....30

**IMMUNITY TEST TO RF CONDUCTED DISTURBANCE.....31**

1 TEST INSTRUMENTS & FACILITIES .....31

2 TEST PROCEDURE.....31

3 TEST SETUP .....32

4 TEST LEVELS.....33

5 CONFIGURATION OF THE EUT.....33

6 EUT OPERATION CONDITION.....33

7 CONDITIONS DURING TESTING.....33

8 PERFORMANCE CRITERIA .....34

9 TEST RESULT.....34

**POWER FREQUENCY MAGNETIC FIELD IMMUNITY TEST .....35**

1 TEST INSTRUMENTS & FACILITIES .....35

2 TEST STANDARD.....35

3 TEST SETUP .....35

4 TEST LEVELS.....36

5 CONFIGURATION OF THE EUT.....36

6 OPERATION CONDITION OF EUT .....36

7 CONDITIONS DURING TESTING.....36



# HomeTek Technology Inc.

8	PERFORMANCE CRITERIA .....	36
9	TEST RESULTS .....	37
<b>VOLTAGE DIPS, SHORT INTERRUPTIONS IMMUNITY TEST .....</b>		<b>38</b>
1	TEST PROCEDURE.....	38
2	RESULT OF VOLTAGE DIPS, SHORT INTERRUPTIONS IMMUNITY TEST.....	38
<b>APPENDIX A</b>		
PHOTOS OF TEST CONFIGURATION		
<b>APPENDIX B</b>		
PHOTOS OF EUT		

## GENERAL INFORMATION

- 1 APPLICANT : SMART CABLING & TRANSMISSION CORP.
- 2 ADDRESS : 7F-1, No. 168, Lien Cheng Rd.,  
Chung-Ho City, Taipei Hsien, Taiwan, R. O. C.
- 3 MANUFACTURER : SMART CABLING & TRANSMISSION CORP.
- 4 ADDRESS : 7F-1, No. 168, Lien Cheng Rd.,  
Chung-Ho City, Taipei Hsien, Taiwan, R. O. C.
- 5 DESCRIPTION OF EUT :
- EUT : Power Distributor BOX
- Model : PD00XXX
- Serial # : N/A
- Data Cable : N/A

5.1 The difference between series of models PD00XXX is shown as below:

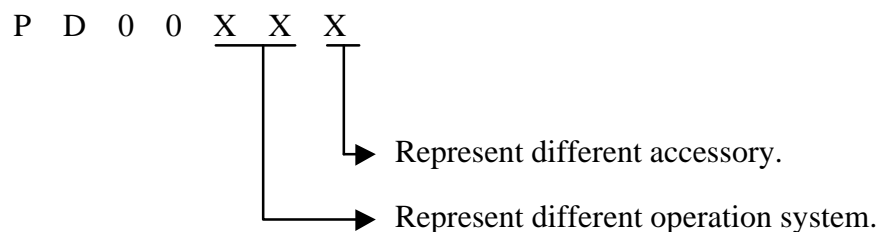

The worst case of EMC test model is PD009 and the final test data were shown in this test report.

6 FEATURES OF EUT :

**Please refer to user manual or product specification.**

7 TEST MODE :

The EUT were investigated with two power source modes shown as below:

(1) DC 12V output mode;

(2) DC 24V output mode

The worst case of EMC test mode is (2) DC 24V output mode and the final test data were shown in this test report.



HomeTek Technology Inc.

## **MODIFICATION LIST**

THE FOLLOWING ACCESSORIES WERE ADDED TO THE EUT DURING TESTING :

NO MODIFICATION BY HOMETEK TECHNOLOGY INC.



## **CONDUCTED POWER LINE TEST**

### **1 TEST PROCEDURE**

According to **EN 61000-6-3**.

### **2 RESULT OF CONDUCTED EMISSION TEST**

N/A (Conducted Power Line Test is not applicable to this EUT ( Model : PD009)).

## RADIATED EMISSION TEST

### 1 TEST INSTRUMENTS & FACILITIES

The following test Instruments was used during the radiated emission test :

Item	Instruments /facilities	Specification	Manufacturer	Model # / S/N#	Date of Cal.
1	OPEN AREA TEST SITE	☑ OATS 3			JUL/2004
2	EMI TEST RECEIVER	30MHz ~ 1GHz	ROHDE & SCHWARZ	ESVS10 845165/017	SEP/2004
3	RF SPECTRUM ANALYZER	N/A	HEWLETT PACKARD	8591E 3710A06158	MAY/2004
4	PRE-AMPLIFIER	9KHz ~ 3000MHz	ADVANTEST	BB525C 90081001	SEP/2004
5	ANTENNA (BI-LOG)	25MHz ~ 2GHz	SCHAFFNER	CBL6112B S/N : 2614	MAY/2004
6	Attenuation	50 /6dB	JYE BAO	FAT-N (M-F) 001	JUL/2004
7	Cable	10m	SUHNER	RG214/U OS3-003	DEC/2004
8	Cable	14m	BELDEN	9913 OS3-001	DEC/2004
9	EMI 32 (software)	N/A	AUDIX	19991013-0923	N/A

Note : Items 1 ~ 8 were calibrated within period of 1 year.

## 2 TEST PROCEDURE

- 2.1 The EUT was test according to **CISPR 22 Class B**.
- 2.2 The radiated test was performed at HomeTek Lab’s Open Site III.
- 2.3 The frequency range from 30 MHz to 1 GHz, the measurement were made at 10 meters, with a BI-log antenna.

## 3 TEST SETUP

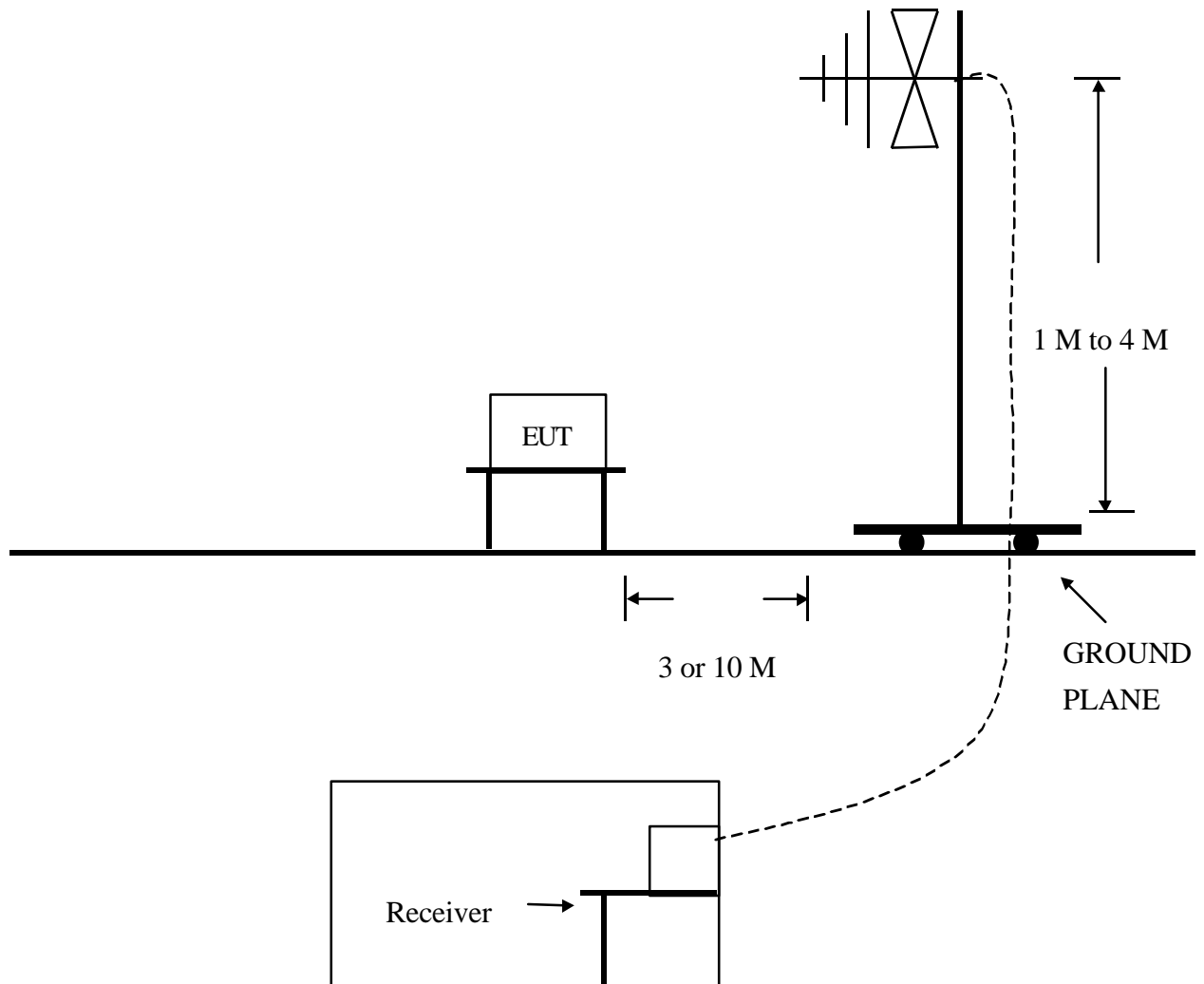

(Details for setup configuration, please refer to appendix A.)

#### 4 CONFIGURATION OF THE EUT

The EUT was configured according to **EN 61000-6-3**. All I/O ports were connected to the appropriate peripherals. All peripherals and cables are listed below (including internal device) :

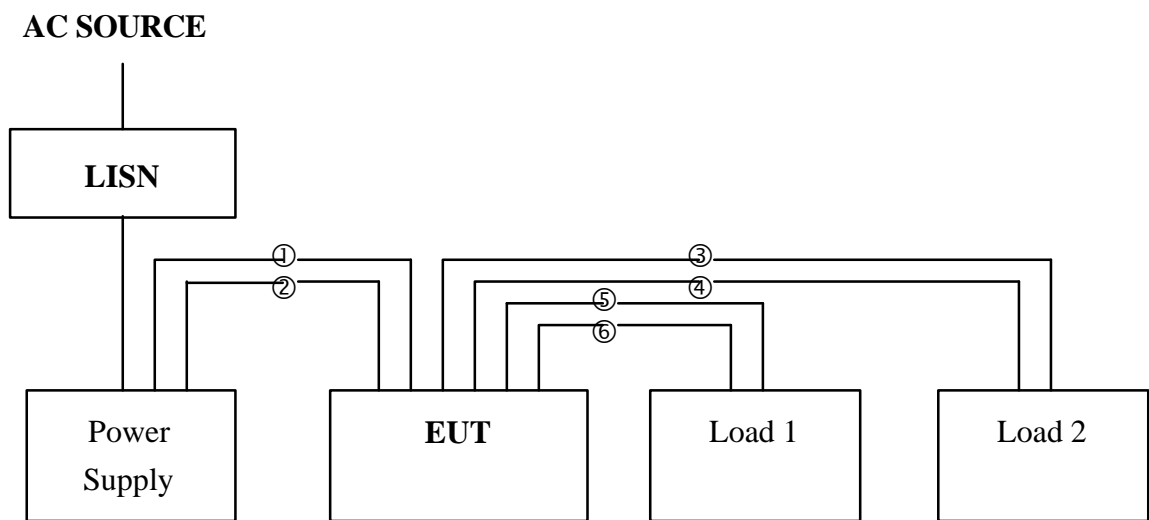

- ① DC+ Power Cable x 16
- ② DC- Power Cable x 16
- ③ DC+ Power Cable x 5
- ④ DC- Power Cable x 5
- ⑤ DC+ Power Cable x 4
- ⑥ DC- Power Cable x 4

Figure 1



4.1 EUT

EUT Type : Proto Type Engineer Type Mass Production  
Condition when received : Good Damage : \_\_\_\_\_  
Device : Power Distributor BOX  
Applicant : SMART CABLING & TRANSMISSION CORP.  
Manufacturer : SMART CABLING & TRANSMISSION CORP.  
Model Number : PD00XXX  
Serial Number : N/A  
FCC ID : N/A  
Data Cable : N/A  
Power Cord (DC-IN) : Un-Shielded, 1.0 m, 2 pin  
Power Cord (DC-OUT) : Un-Shielded, 1.0 m, 2 pin  
Power Supply Type : Linear power supply

4.2 PERIPHERALS

Power Supply

Manufacturer : SMART CABLING & TRANSMISSION CORP.  
Model Number : PW816  
Serial Number : N/A  
FCC ID : N/A  
Data Cable : N/A  
Power Cord (AC) : Un-Shielded, 1.8 m  
Power Cord (DC) : Un-Shielded, 1.0 m



Load 1 x 2

Manufacturer : HomeTek  
Specification : DC 24V / 6R / 120W  
Power Cord : Un-Shielded, 1.0 m

Load 2

Manufacturer : HomeTek  
Specification : DC 12V / 1.5R / 120W  
Power Cord : Un-Shielded, 1.0 m

4.3 REMARK : N/A

## 5 EUT OPERATING CONDITION

- 5.1 The frequency of the EUT is none.
- 5.2 Configure the EUT according to the **EN 61000-6-3**.
- 5.3 Connect AC source 230V to input port of Support Unit (Power Supply)
- 5.4 DC 24V output mode:
  - DC 24V output port of Support Unit (Power Supply) connect to input port of EUT.
  - EUT' s DC 24V output port connect to dummy load (6R/120W Resistor x 2).
  - Monitor the status of output port of EUT during the test (For EMS Testing).
- 5.5 DC 12V output mode:
  - DC 12V output port of Support Unit (Power Supply) connect to input port of EUT.
  - EUT' s DC 12V output port connect to dummy load (1.5R/120W Resistor).
  - Monitor the status of output port of EUT during the test (For EMS Testing)
- 5.6 **The photos of conducted test configuration, please refer to appendix A.**

## 6 LIMIT OF RADIATED EMISSION CLASS B

Frequency (MHz)	Measurement Distance	Limit (dBuV/m)
30 - 230	10 (M)	30
230 - 1000	10 (M)	37

## 7 RESULT OF RADIATED EMISSION TEST

- 7.1 The frequency range from 30 MHz to 1 GHz was investigated.
- 7.2 All readings below or equal 1 GHz are quasi-peak or peak values with resolution bandwidth of 120 KHz.
- 7.3 The measurements were made at 10 meters of HomeTek Lab' s open site III.
- 7.4 Temperature : 33 , Humidity : 55 % RH.
- 7.5 Deviation form the test standards and rules : None.
- 7.6 The radiated emission result were gained by the following method :  
 Level = Reading Level + Probe Factor (Antenna Factor) + Cable Loss – Preamp Factor  
 Over Limit = Level – Limit Line
- 7.7 Result : **PASSED**



HomeTek Technology Inc.

No. 67-9, Shi-Men Rd., Tu-Chen City, Taipei County, Taiwan R.O.C.  
Tel: 02-22608375  
Fax: 02-22748013

Data#: 3 File#: 4a026.emi

Date: 2005-01-18 Time: 10:58:13

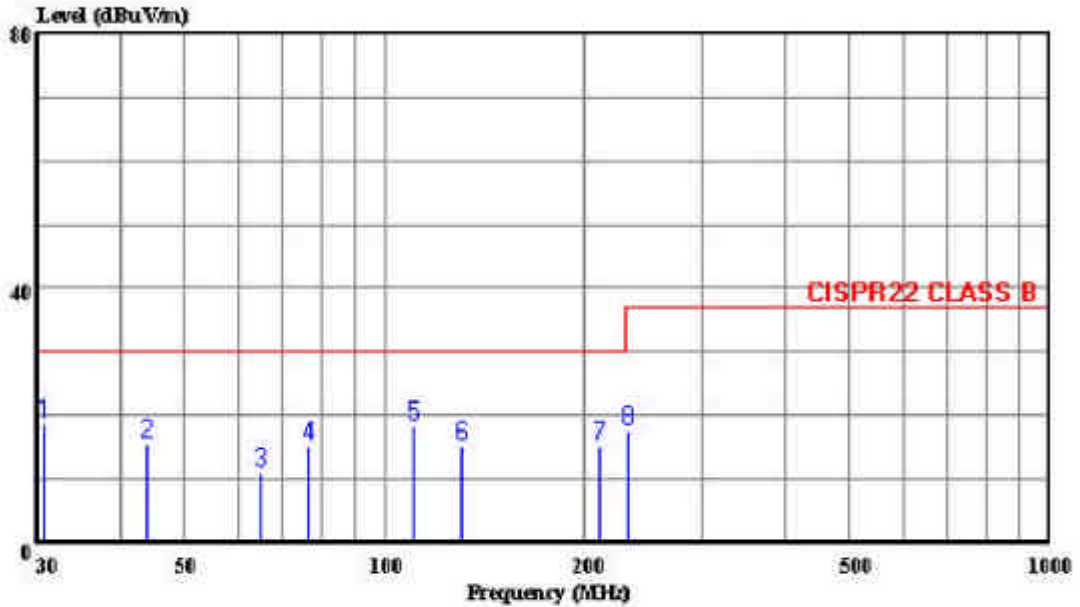

Trace:

Ref Trace:

Condition: CISPR22 CLASS B 10m CHASE 2614 052604 HORIZONTAL  
 sut : Power Distributor Box (PD009)  
 power: FROM Power Supply (230V/50Hz)  
 memo : 24V MODE

Page: 1

	Freq	Level	Limit	Over	ReadAntenna	Cable	Preamp	
	MHz	dBUV/m	dBUV/m	dB	Level	Loss	Loss	Remark
					Factor	Factor	Factor	
					dB/m	dB	dB	
1	30.652	18.60	30.00	-11.40	30.52	17.20	0.77	29.89 Peak
2	43.851	15.68	30.00	-14.32	33.63	11.04	0.89	29.89 Peak
3	65.147	11.24	30.00	-18.76	34.17	5.64	1.06	29.62 Peak
4	76.634	15.32	30.00	-14.68	37.13	6.48	1.14	29.43 Peak
5	110.361	18.45	30.00	-11.55	34.67	11.51	1.38	29.10 Peak
6	130.524	15.27	30.00	-14.73	31.64	11.36	1.49	29.22 Peak
7	210.502	15.27	30.00	-14.73	34.42	8.50	1.96	29.61 Peak
8	232.124	17.77	37.00	-19.23	36.11	9.16	2.10	29.59 Peak



HomeTek Technology Inc.

No. 67-9, Shi-Men Rd., Tu-Chen City,  
 Taipei County, Taiwan R.O.C.  
 Tel: 02-22608375  
 Fax: 02-22748013

Data#: 4 File#: 4a026.eml

Date: 2008-01-18 Time: 12:36:51

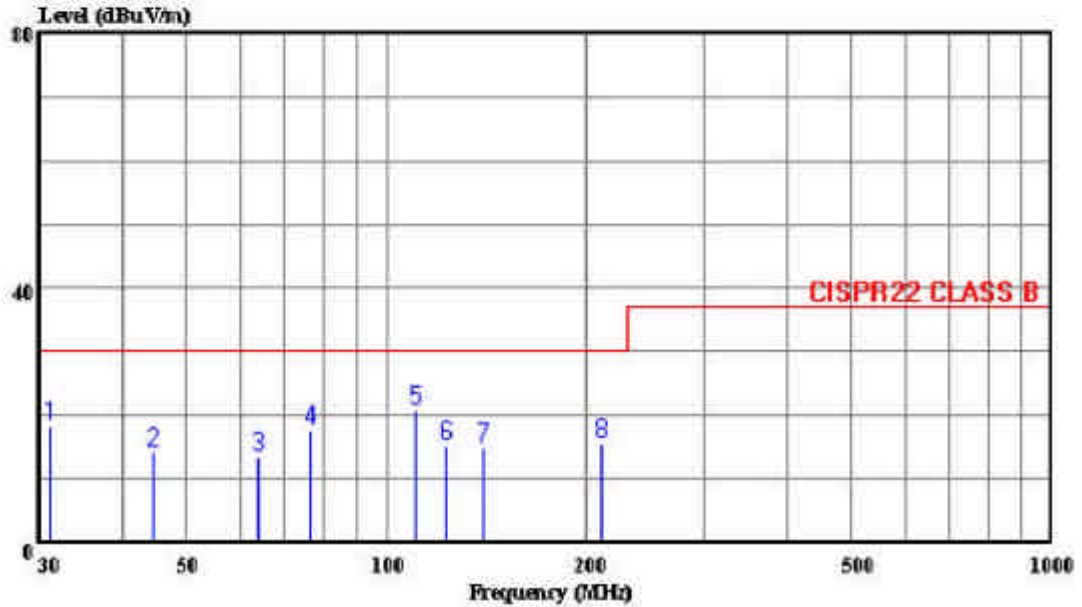

Trace:

Ref Trace:

Condition: CISPR22 CLASS B 10m CHASE 2614 052604 VERTICAL  
 aut : Power Distributor Box (PD009)  
 power: BROM Power Supply (230V/50Hz)  
 memo : 24V MODE

Page: 1

	Freq	Level	Limit	Over	ReadAntenna	Cable	Precamp	Remark
	MHz	dBuV/m	dBuV/m	dB	dBW	dB/m	dB	dB
1	31.224	18.50	30.00	-11.50	30.64	16.97	0.70	29.89 Peak
2	44.637	14.09	30.00	-15.91	32.28	10.80	0.90	29.89 Peak
3	64.115	13.63	30.00	-16.37	36.57	5.64	1.05	29.64 Peak
4	76.783	17.75	30.00	-12.25	39.52	6.51	1.15	29.43 Peak
5	110.634	20.95	30.00	-9.05	37.16	11.51	1.38	29.10 Peak
6	122.472	15.32	30.00	-14.68	31.42	11.63	1.45	29.17 Peak
7	140.034	14.87	30.00	-15.13	32.05	10.55	1.55	29.27 Peak
8	210.362	15.52	30.00	-14.48	34.68	8.50	1.95	29.61 Peak



## **HARMONICS TEST**

### **1 TEST PROCEDURE**

According to **EN 61000-3-2 (2000)**.

### **2 RESULT OF HARMONICS TEST**

N/A (This standard is not applicable to this EUT ( Model : PD009)).

## **VOLTAGE FLUCTUATIONS TEST**

### **1 TEST PROCEDURE**

According to **EN 61000-3-3 (1995) + A1 (2001)**.

### **2 RESULT OF VOLTAGE FLUCTUATIONS TEST**

N/A (This standard is not applicable to this EUT ( Model : PD009)).

## ELECTROSTATIC DISCHARGE IMMUNITY TEST (ESD)

### 1 TEST INSTRUMENTS & FACILITIES

Instruments/ Facilities	Manufacturer	Model # Serial #	Data Of Cal.
ESD TESTER	NOISEKEN	ESS-100L (A)	OCT/2004
VCP	HOMETEK	--	--

### 2 TEST PROCEDURE

According to **IEC 61000-4-2 (2001)**

According to **EN 61000-6-1 (2001)**

### 3 TEST SETUP

TABLE SIZE

160L X 80W X 80H cm

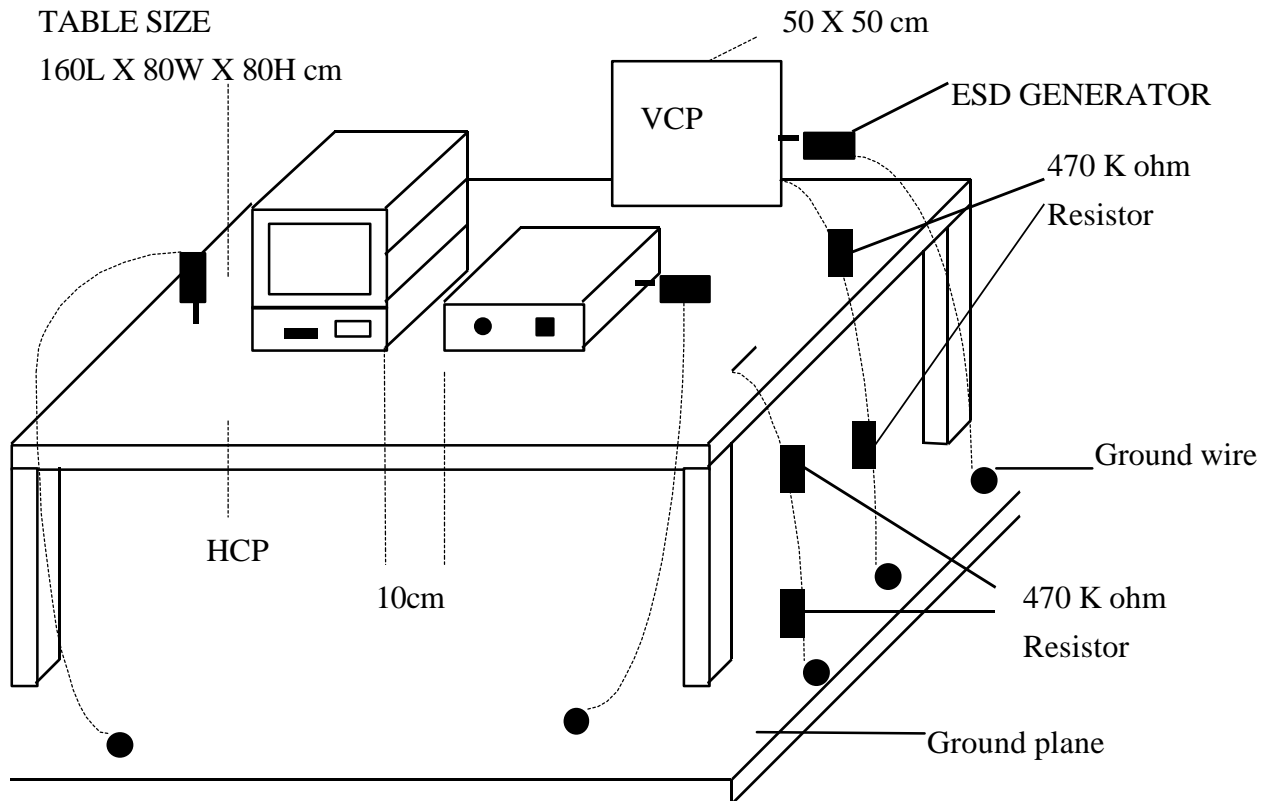

(Details for setup configuration, please refer to appendix A.)

#### 4 CONFIGURATION OF THE EUT

Same as “Radiated Emission Test”, section 4

#### 5 EUT OPERATION CONDITION

Same as “Radiated Emission Test”, section 5

#### 6 TEST CONDITION

6.1 Test Level :

(A)  $\pm 2, 4, 8$ KV for air discharge.

(B)  $\pm 2, 4$ KV for contact discharge.

6.2 Number of test : 10 Discharges / Level

6.3 Time between test : 1 sec.

6.4 Temperature : 22

6.5 Humidity : 56 % RH.

#### 7 PERFORMANCE CRITERIA

A. Normal performance within the specification.

B. Temporary degradation or loss function or performance which is self-recoverable.

C. Temporary degradation or loss function or performance which requires operator intervention system reset.

D. Degradation or loss function which is not recoverable due to damage of EUT or software, or loss of data.

8 TEST RESULT

Test Point	Air Discharge	Contact Discharge	Performance Criteria	Result
HCP	---	± 2, 4KV	A	<b>PASSED</b>
VCP	---	± 2, 4KV	A	<b>PASSED</b>
CASE	± 2, 4, 8KV	± 2, 4KV	A	<b>PASSED</b>
I/O PORTS	± 2, 4, 8KV	± 2, 4KV	A	<b>PASSED</b>
LED	± 2, 4, 8KV	± 2, 4KV	A	<b>PASSED</b>
SCREWS	± 2, 4, 8KV	± 2, 4KV	A	<b>PASSED</b>
DC SOCKET	± 2, 4, 8KV	± 2, 4KV	A	<b>PASSED</b>

9 Photos of test configuration please refer to appendix A.

## RADIO FREQUENCY ELECTROMAGNETIC FIELD IMMUNITY TEST (RS)

### 1 TEST INSTRUMENTS & FACILITIES

Item	Instruments Facilities	Manufacturer	Model # Serial #	Data Of Cal.
1	SIGNAL GENERATOR	ROHDE & SCHWARZ	SMY02 845181/025	MAR/2004
2	AMPLIFIER	AMPLIFIER RESEARCH	100W1000M1A	N/A
3	FIELD SENSOR	AMPLIFIER RESEARCH	FP2000	AUG/2004
4	FIELD MONITOR	AMPLIFIER RESEARCH	FM2000	AUG/2004
5	RF VOLTMETER	BOONTON	9200C 361701AA	MAR/2004
6	RF PROBE	BOONTON	952001B 37082	MAR/2004
7	DIRECTION COUPLER	AMPLIFIER RESEARCH	DC6180 20521	N/A
8	ANTENNA	EMCO	3142B S/N: 1789	N/A
9	CONTROL PC	KB TECH	KB P586/133	--

Note : Items 3 ~ 4 were calibrated with two years and verified before testing.

### 2 TEST PROCEDURE

According to **IEC 61000-4-3 (2002)**

According to **EN 61000-6-1 (2001)**

### 3 TEST SETUP

#### FERRITE TILE

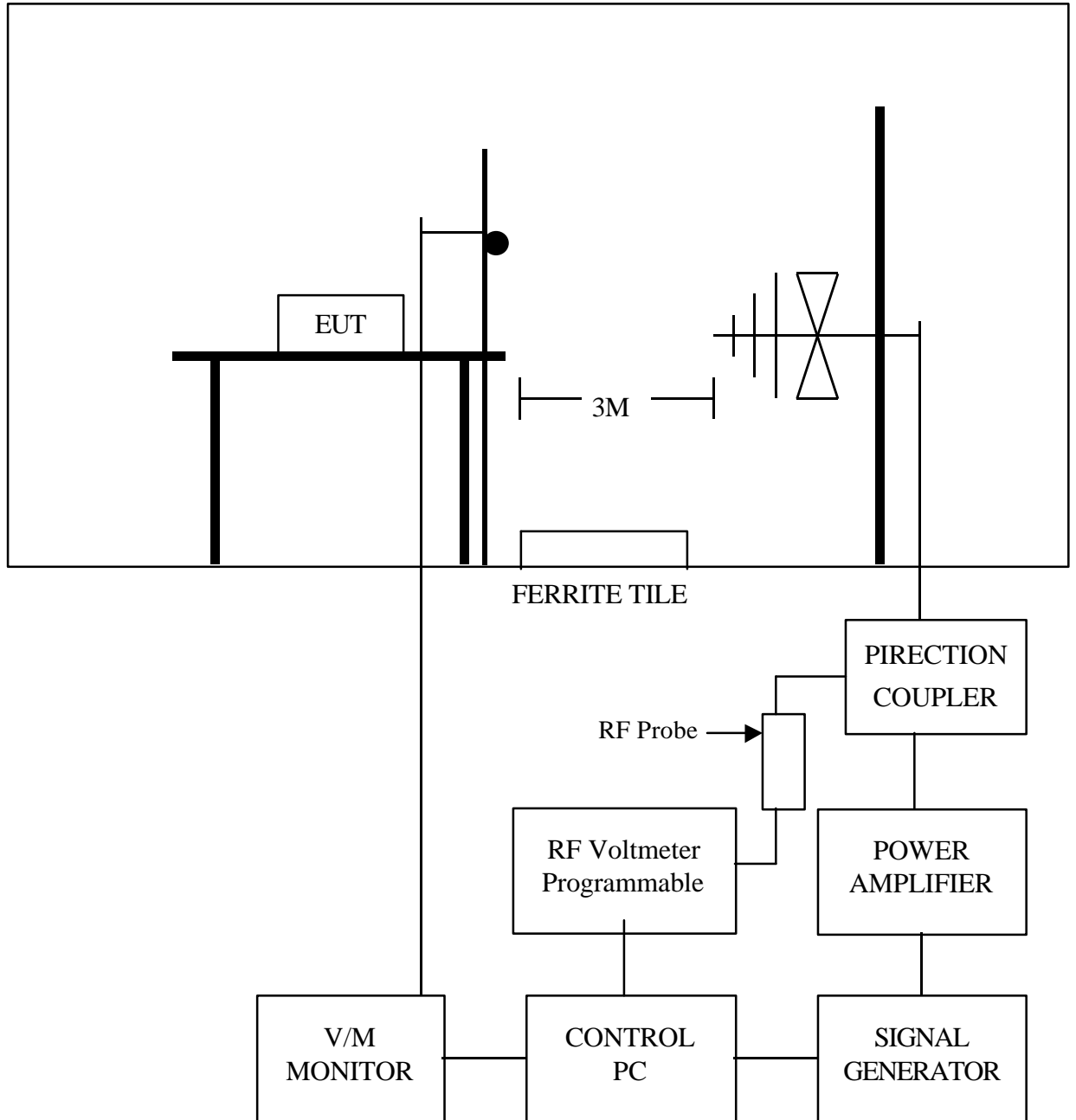

#### 3.1 Chamber Size :

12M x 5M x 5M

(Details for setup configuration, please refer to appendix A.)

#### 4 CONFIGURATION OF THE EUT

Same as “Radiated Emission Test”, section 4

#### 5 OPERATION CONDITION OF EUT

Same as “Radiated Emission Test”, section 5

#### 6 TEST CONDITION

6.1 Frequency Range : 80 MHz ~ 1000 MHz

(Frequency Range : 1.4 GHz ~ 2.0 GHz is not applicable for EN61000-6-1:2001)

6.2 Filed Strength : 3 V / M (1KHz 80% Modulation)

6.3 Frequency Step : 1 %, 3 sec. / each step size

6.4 Antenna Polarity : HORIZONTAL & VERTICAL

6.5 The four sides of EUT are tested  
(FRONT, REAR, RIGHT, LEFT)

6.6 Temperature : 20

6.7 Humidity : 72 % RH

#### 7 PERFORMANCE CRITERIA

- A. Normal performance within the specification.
- B. Temporary degradation or loss function or performance which is self-recoverable.
- C. Temporary degradation or loss function or performance which requires operator intervention system reset.
- D. Degradation or loss function which is not recoverable due to damage of EUT or software, or loss of data.

8 TEST RESULT

ANT SIDE	HORIZONTAL	VERTICAL	RESULT
FRONT	A	A	<b>PASSED</b>
REAR	A	A	<b>PASSED</b>
RIGHT	A	A	<b>PASSED</b>
LEFT	A	A	<b>PASSED</b>

9 Photos of test configuration please refer to appendix A.

## ELECTRICAL FAST TRANSIENT/BURST IMMUNITY TEST (EFT)

### 1 TEST INSTRUMENTS & FACILITIES

Instruments/ Facilities	Manufacturer	Model # Serial #	Data Of Cal.
BURST-TESTER	HAEFELY	PEFT/JUNIOR	FEB/2004
CONTROL PC	KB TECH	KB P586/133	--

### 2 TEST PROCEDURE

According to **IEC 61000-4-4 (2004)**

According to **EN 61000-6-1 (2001)**

### 3 TEST SETUP

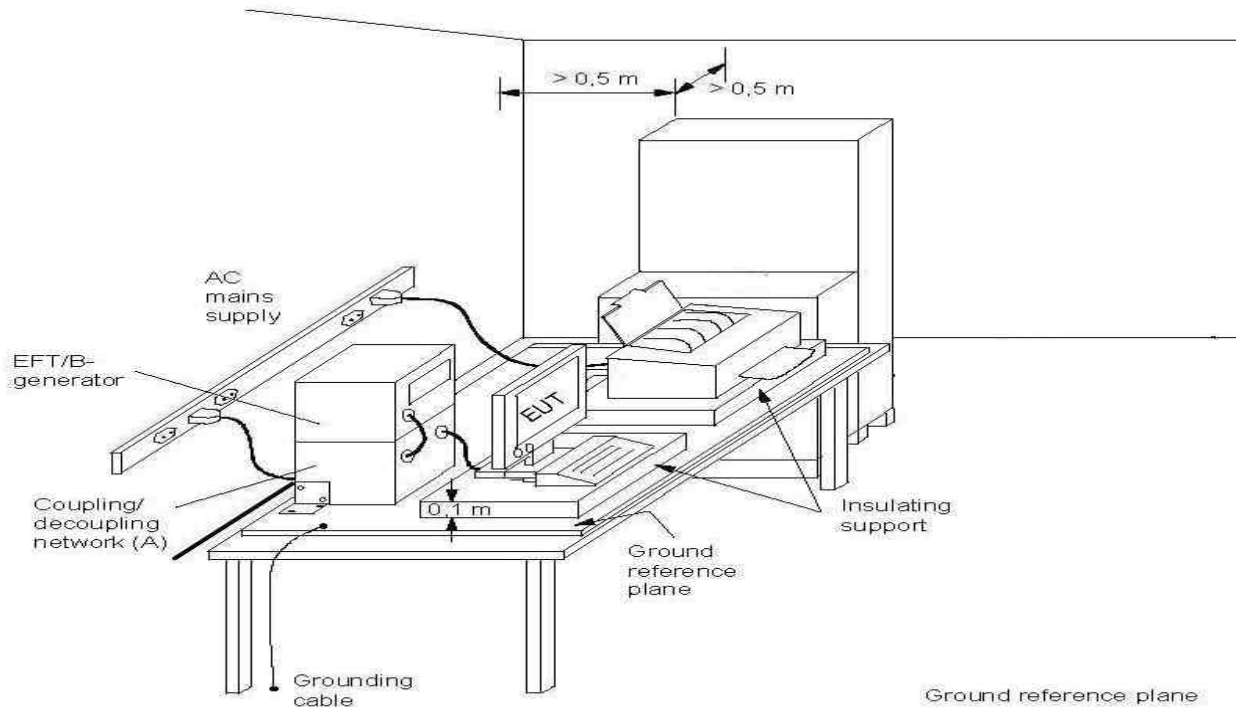

(Details for setup configuration, please refer to appendix A.)

Note: length between clamp and the EUT to be tested (should be  $0.5\text{ m} \pm 0.05\text{ m}$ )

(A) location for supply line coupling

(B) location for signal line coupling

#### 4 CONFIGURATION OF THE EUT

Same as “Radiated Emission Test”, section 4

#### 5 OPERATION CONDITION OF EUT

Same as “Radiated Emission Test”, section 5

#### 6 TEST CONDITION

6.1 Pulse Rise time & Duration : 5 nS / 50 nS

6.2 Pulse Repetition : 5 kHz

6.3 Polarity : POSITIVE / NEGATIVE

6.4 Test Voltage :  $\pm 0.5KV$ ,  $\pm 1KV$

6.5 Coupling of power line :  
L, N, L+N

6.6 Temperature : 20

6.7 Humidity : 72 % RH

#### 7 PERFORMANCE CRITERIA

- A. Normal performance within the specification.
- B. Temporary degradation or loss function or performance which is self-recoverable.
- C. Temporary degradation or loss function or performance which requires operator intervention system reset.
- D. Degradation or loss function which is not recoverable due to damage of EUT or software, or loss of data.

## 8 TEST RESULT

TEST VOLTAGE	L	N	L+N
$\pm 0.5KV$	A	A	A
$\pm 1KV$	A	A	A

8.1 Model : PD009

8.2 Test Mode : DC 24V output mode

8.3 Final Result : PASSED

8.4 Remark :

## 9 Photos of test configuration please refer to appendix A.

## SURGE IMMUNITY TEST

### 1 TEST INSTRUMENTS & FACILITIES

Instruments/ Facilities	Manufacturer	Model # Serial #	Data Of Cal.
SURGER-TESTER	HAEFELY	PSURGE 4010 583334- 38	FEB/2004
CONTROL PC	KB TECH	KB P586/133	--

### 2 TEST PROCEDURE

According to **IEC 61000-4-5 (2001)**

According to **EN 61000-6-1 (2001)**

### 3 TEST SETUP

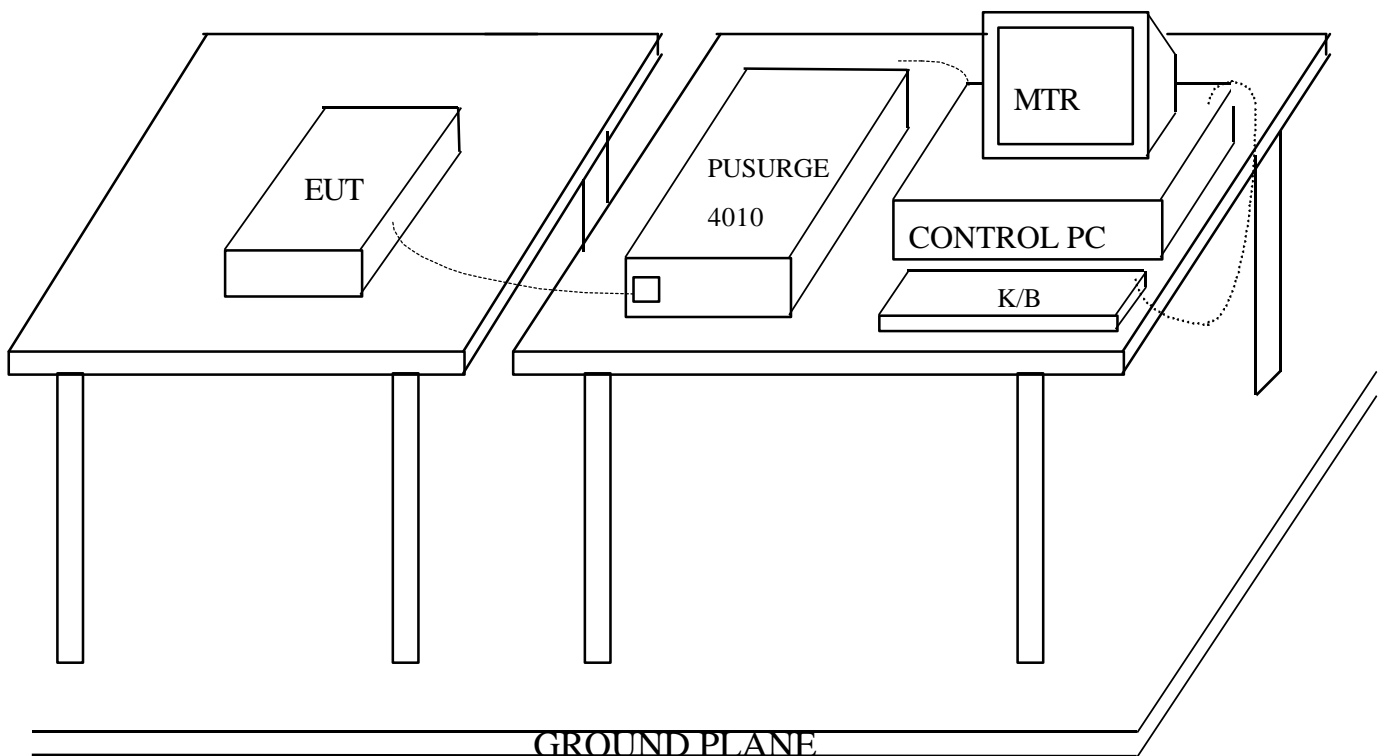

(Details for setup configuration, please refer to appendix A.)

#### 4 TEST LEVELS

- Input and Output AC Power Ports.
- DC Input and DC Output Power Ports.

Environmental Phenomena	Test Specification		Units	Performance Criteria
	AC	DC		
Surges	1.2 / 50 (8/20)		Tr /Th us	
Line to Line	± 1	± 0.5	KV (Charge Voltage)	B

#### 5 CONFIGURATION OF THE EUT

Same as “Radiated Emission Test”, section 4

#### 6 EUT OPERATION CONDITION

Same as “Radiated Emission Test”, section 5

#### 7 CONDITIONS DURING TESTING

7.1 Coupling of power line :

(A) Line to Line ± 1KV (AC) or ± 0.5KV (DC)

7.2 Polarity : POSITIVE / NEGATIVE

7.3 Phase shifting in a range between 0 ° to 360 °

7.4 Repetion rate at least 1 per min

7.5 Temperature : 22 (15 ~ 35 )

Humidity : 70 % RH.(10 % ~ 75%)

## 8 PERFORMANCE CRITERIA

- A. Normal performance within the specification limits.
- B. Temporary degradation or loss of function or performance which is self-recoverable.
- C. Temporary degradation or loss of function or performance which requires operator intervention or system reset.
- D. Degradation or loss of function which is not recoverable due to damage of equipment (components).

## 9 TEST RESULT

Environmental Phenomena	Test Specification	Units	Performance
Line to Line	$\pm 1$	KV (Charge Voltage)	A

9.1 Model : PD009

9.2 Test Mode : DC 24V output mode

9.3 Final Result : PASSED

9.4 Remark :

## IMMUNITY TEST TO RF CONDUCTED DISTURBANCE

### 1 TEST INSTRUMENTS & FACILITIES

Instruments/ Facilities	Manufacturer	Model # Serial #	Date Of Cal.
SIGNAL GENERATOR	ROHDE & SCHWARZ	SMY02 845181/025	MAR/2004
AMPLIFIER	AMPLIFIER RESEARCH	75A250 25680	N/A
RF VOLTMETER	BOONTON	9200C 361701AA	MAR/2004
RF PROBE	BOONTON	952001B 37082	MAR/2004
DIRECTION COUPLER	AMPLIFIER RESEARCH	DC2600 20508	N/A
COUPLING DECOUPLING NETWORK	FCC	FCC-801-M3-25A 9993	FEB/2004
CONTROL PC	KB TECH	KB P586/133	--

### 2 TEST PROCEDURE

According to **IEC 61000-4-6 (2003) + A1 (2004)**

According to **EN 61000-6-1 (2001)**

### 3 TEST SETUP

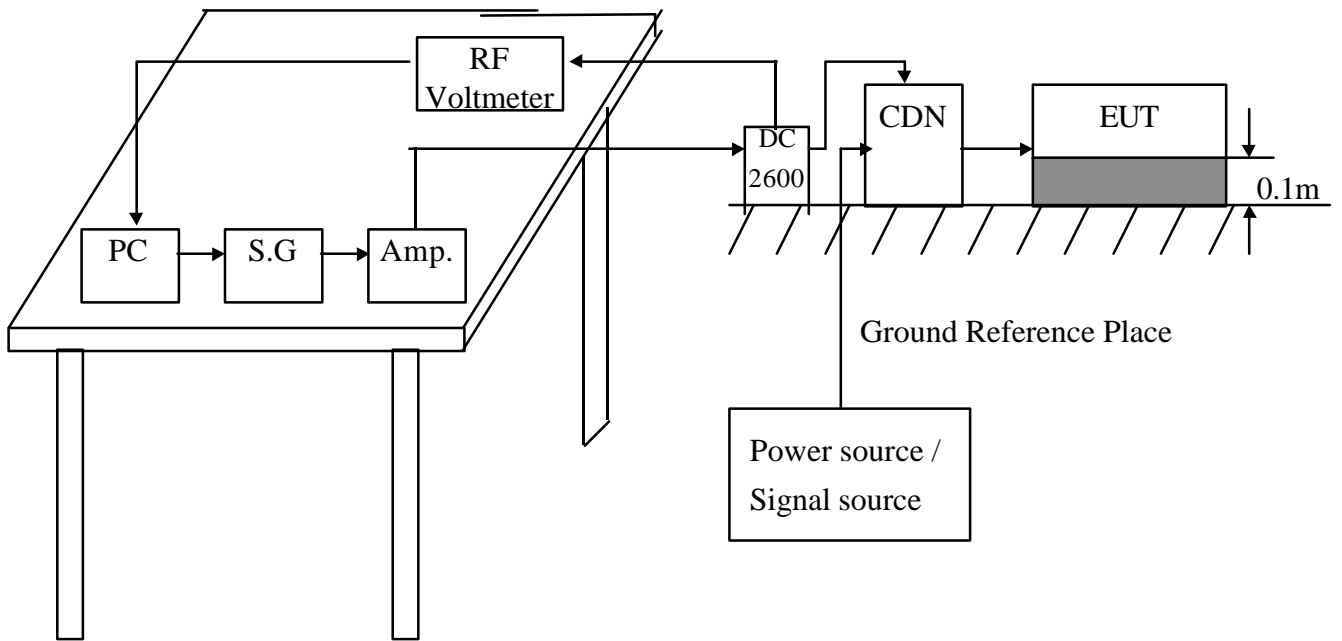

(Details for setup configuration, please refer to appendix A.)

#### 4 TEST LEVELS

- Ports for signal lines and control lines.
- DC input and DC output power ports.
- Input and Output AC Power Ports.
- Functional earth Ports.

Environmental	Test Specification	Units	Performance
Radio-frequency	0.15 - 80	MHz	
Common mode	3	V	A
	80	% AM (1KHz)	

#### 5 CONFIGURATION OF THE EUT

Same as “Radiated Emission Test”, section 4

#### 6 EUT OPERATION CONDITION

Same as “Radiated Emission Test”, section 5

#### 7 CONDITIONS DURING TESTING

7.1 The EUT tested type :

- Single unit
- Multiple unit

7.2 Dwell time : < 1%

7.3 Temperature : 24 (15 ~ 35 )

Humidity : 72 % RH.(10 % ~ 75%)

8 PERFORMANCE CRITERIA

- A. Normal performance within the specification limits.
- B. Temporary degradation or loss of function or performance which is self-recoverable.
- C. Temporary degradation or loss of function or performance which requires operator intervention or system reset.
- D. Degradation or loss of function which is not recoverable due to damage of equipment (components).

9 TEST RESULT

TEST Specification	Unit	Performance Criteria
0.15 - 80	MHz	A
3	V	
80	% AM (1KHz)	

9.1 Model : PD009

9.2 Test Mode : DC 24V output mode

9.3 Final Result : PASSED

9.4 Remark :

## POWER FREQUENCY MAGNETIC FIELD IMMUNITY TEST

### 1 TEST INSTRUMENTS & FACILITIES

Instruments/ Facilities	Manufacturer	Model # Serial #	Data Of Cal.
LINE INTERFERENCE TESTER	HAEFELY	PLINE 1610 080166-10	MAR/2004
MAGNETIC FIELD TESTER	HAEFELY	MAG 100.1 080206-01	N/A
TRIAXIAL ELF MAGNETIC FIELD METER	F.W.BELL	4080 9645	JUN/2004
CONTROL PC	KB TECH	KB P586/133	--

### 2 TEST STANDARD

According to **IEC 61000-4-8 (2001)**

According to **EN 61000-6-1 (2001)**

### 3 TEST SETUP

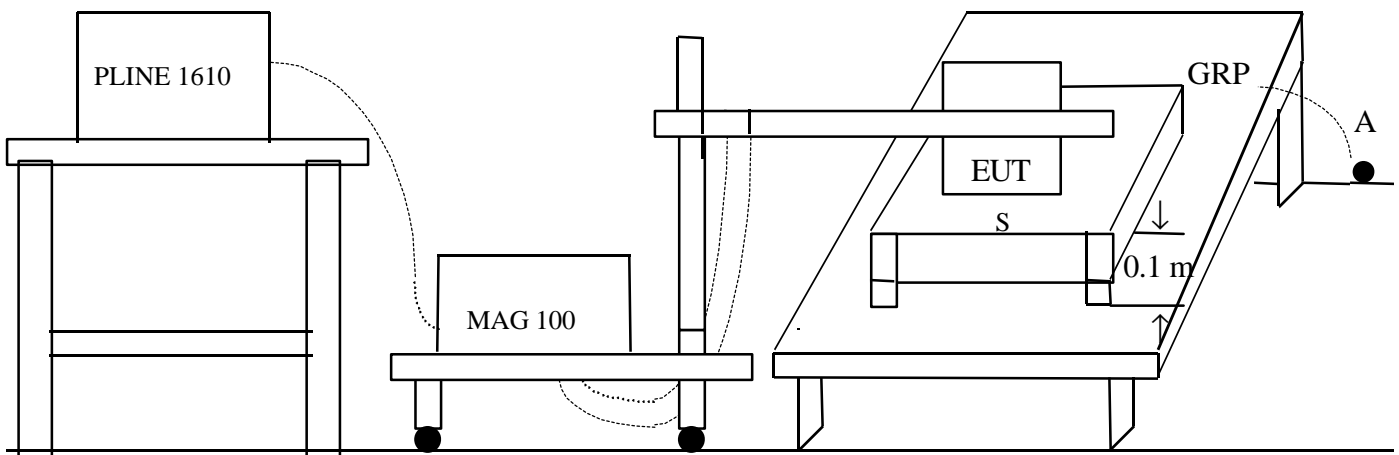

S: Insulating support

A: Safety earth

GRP: Ground plane

(Details for setup configuration, please refer to appendix A.)

#### 4 TEST LEVELS

Environmental Phenomena	Test Specification	Units	Performance Criteria
Power Frequency	50	HZ	
Magnetic Field	3	A/m	A

#### 5 CONFIGURATION OF THE EUT

Same as “Radiated Emission Test”, section 4

#### 6 OPERATION CONDITION OF EUT

Same as “Radiated Emission Test”, section 5

#### 7 CONDITIONS DURING TESTING

7.1 Temperature : 21 (15 ~ 35 )

Humidity : 72 % RH.(25 % ~ 75%)

7.2 The induction coil shall be rotated by 90 °

#### 8 PERFORMANCE CRITERIA

- A. Normal performance within the specification limits.
- B. Temporary degradation or loss of function or performance which is self-recoverable.
- C. Temporary degradation or loss of function or performance which requires operator intervention or system reset.
- D. Degradation or loss of function which is not recoverable due to damage of equipment (components).

## 9 TEST RESULTS

Environmental Phenomena	Test Specification	Units	Performance Criteria
Magnetic Field	3	A/m	A

9.1 Model : PD009

9.2 Test Mode : DC 24V output mode

9.3 Final Results : PASSED

9.4 Remark :

## **VOLTAGE DIPS, SHORT INTERRUPTIONS IMMUNITY TEST**

### **1 TEST PROCEDURE**

According to **IEC 61000-4-11 (2004)**

According to **EN 61000-6-1 (2001)**

### **2 RESULT OF VOLTAGE DIPS, SHORT INTERRUPTIONS IMMUNITY TEST**

N/A (This standard is not applicable to this EUT ( Model : PD009)).



HomeTek Technology Inc.

**Appendix A**  
**PHOTOS OF TEST CONFIGURATION**

## PHOTO OF RADIATED EMISSION TEST

Test Mode : DC 24V MOE , Model: PD009

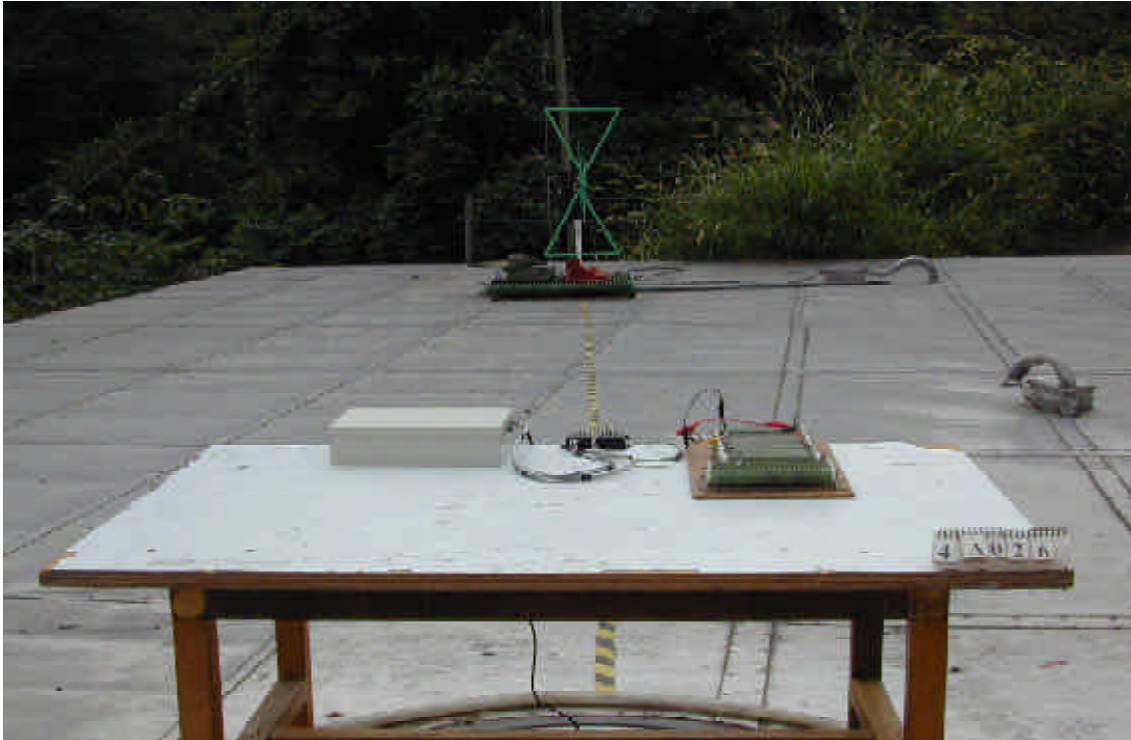

Front View

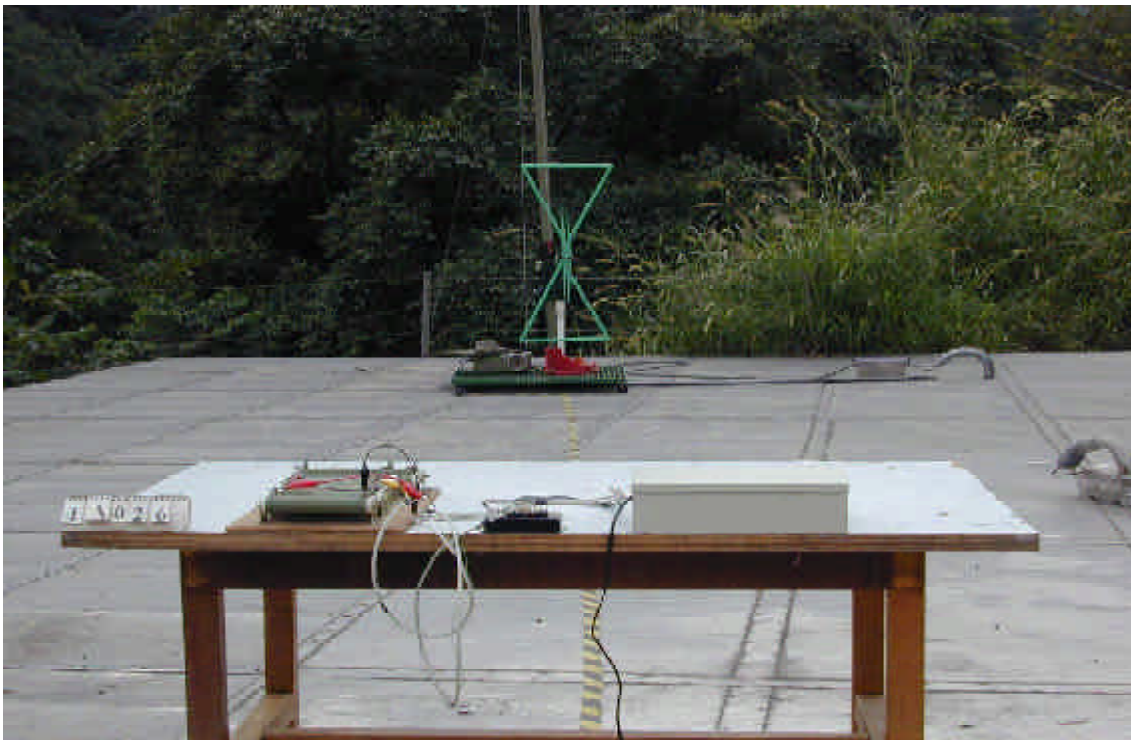

Rear View



**PHOTO OF SURGE IMMUNITY TEST**

Test Mode : DC 24V MOE , Model: PD009



**PHOTO OF ELECTRICAL FAST TRANSIENT/BURST IMMUNITY TEST**





**PHOTO OF ELECTROSTATIC DISCHARGE IMMUNITY TEST  
(ESD)**

Test Mode : DC 24V MOE , Model : PD009

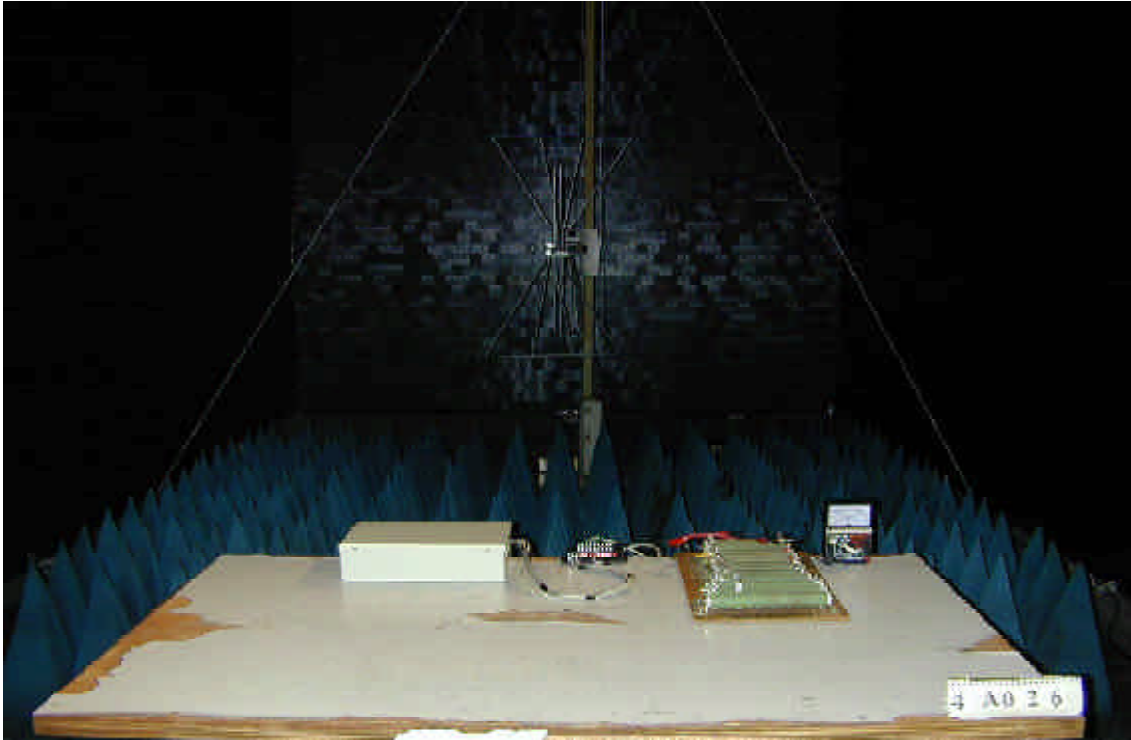

**PHOTO OF POWER FREQUENCY MAGNETIC FIELD  
IMMUNITY TEST**

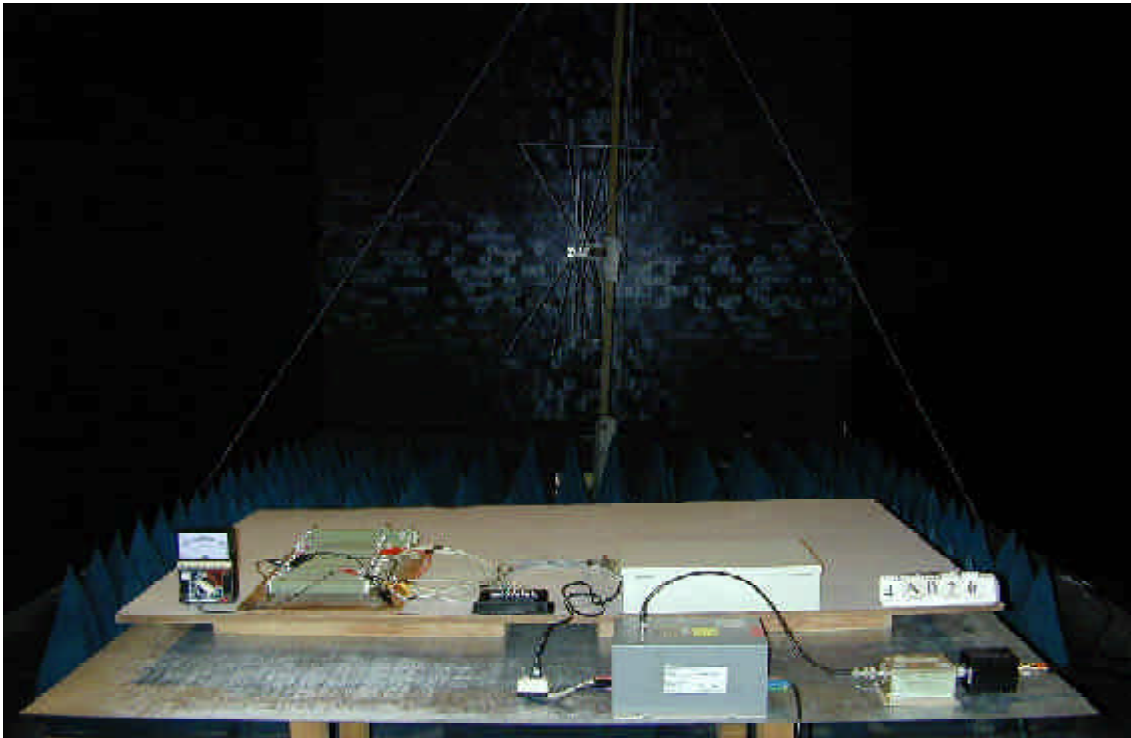

**PHOTO OF RADIO FREQUENCY ELECTROMAGNETIC FIELD IMMUNITY TEST (RS)**

Test Mode : DC 24V MOE , Model : PD009



**PHOTO OF CS CONDUCTED DISTURBANCE IMMUNITY TEST**





HomeTek Technology Inc.

## **Appendix B**

# **PHOTOS OF EUT**

### PHOTO OF EUT

Model : PD009

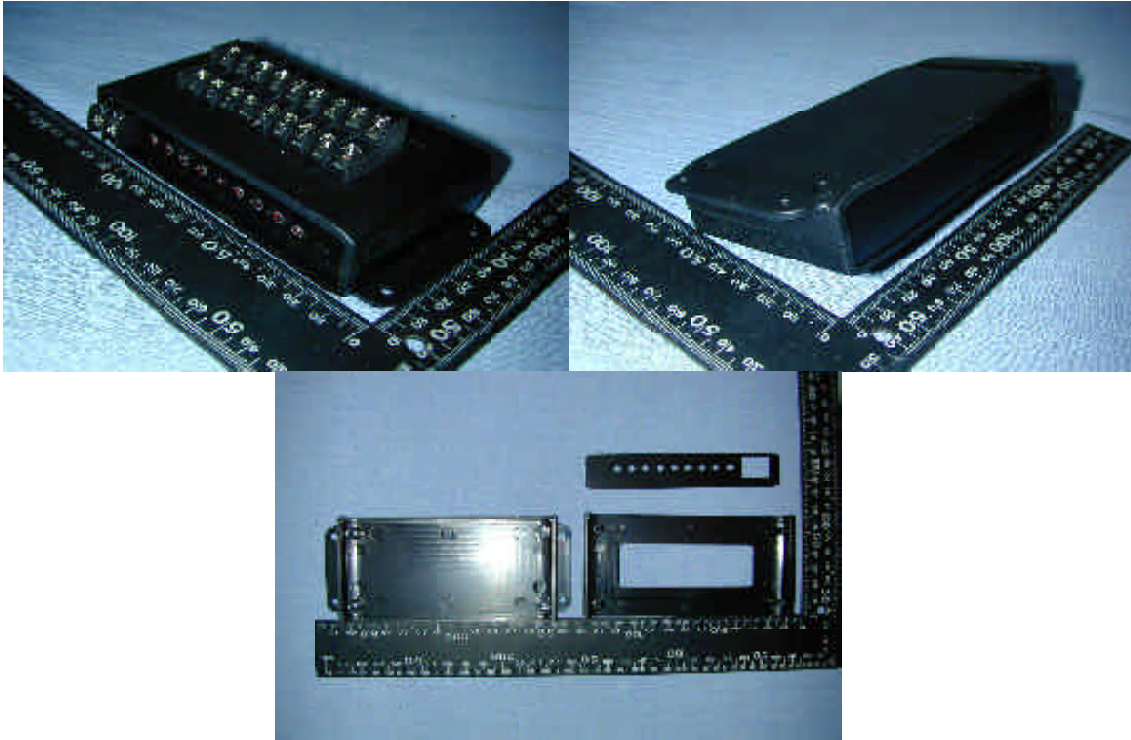

Full View of EUT

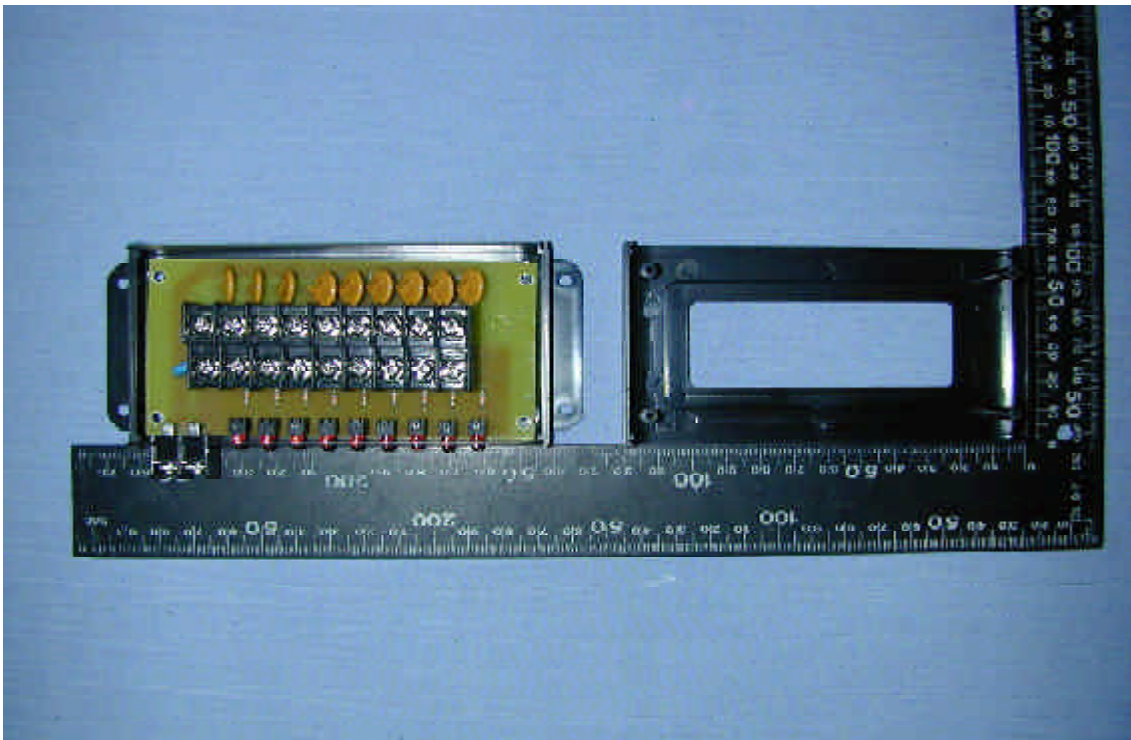

Inside View of EUT

### PHOTO OF EUT

Model : PD009

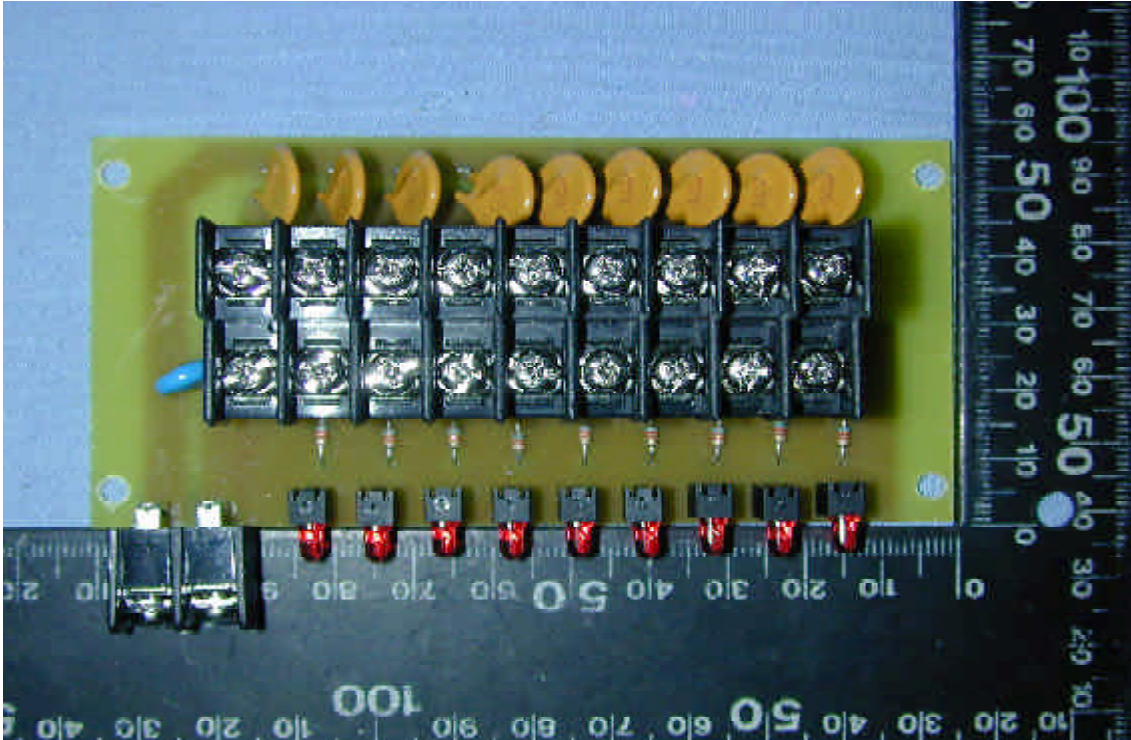

Component Side of Main Board

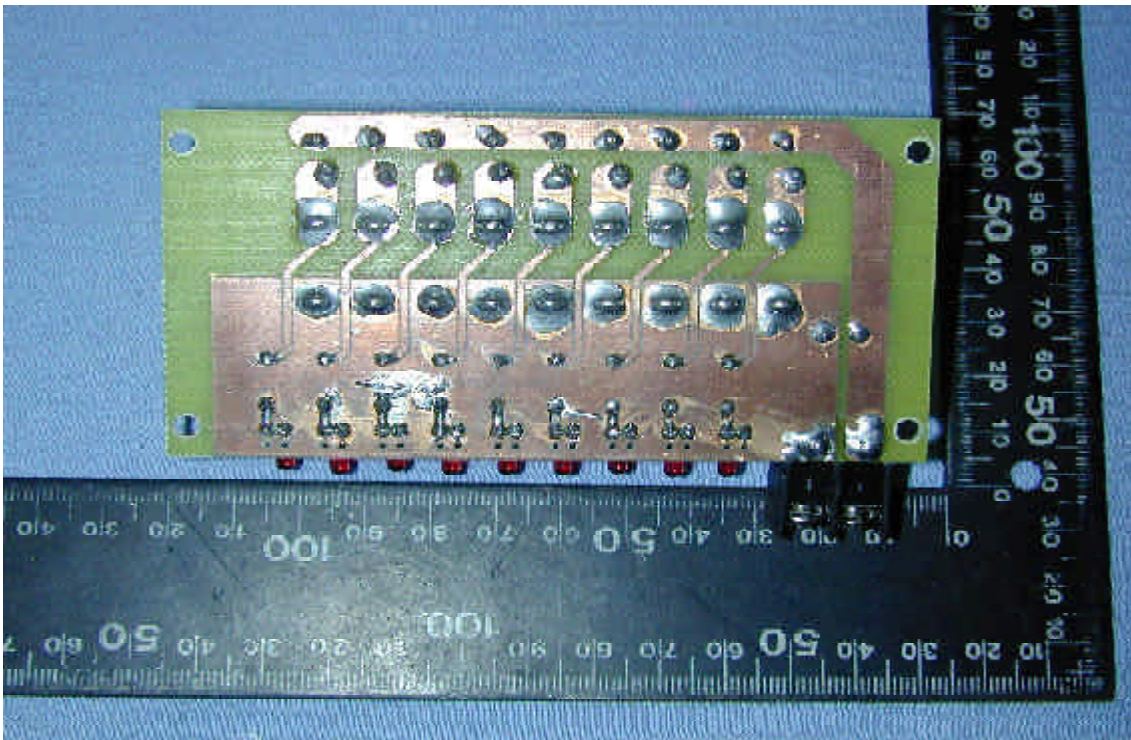

Solder Side of Main Board

# Declaration of Conformity

We(Manufacturer/Importer)

---

(company name)

---

(address)

declares under our sole responsibility that the product

Product name : Power Distributor BOX

Model No. : PD00XXX

to which this declaration relates is in conformity with the following standard(s) or other normative document(s)

- |   |   |
|---|---|
| <input checked="" type="checkbox"/> EN 61000-6-3 (2001)     | <input checked="" type="checkbox"/> EN 61000-6-1 (2001)   |
| <input checked="" type="checkbox"/> CISPR 22 Class B (1997) | <input checked="" type="checkbox"/> IEC 61000-4-2 (2001)  |
| <input checked="" type="checkbox"/> EN 61000-3-2 (2000)     | <input checked="" type="checkbox"/> IEC 61000-4-3 (2002)  |
| <input checked="" type="checkbox"/> EN 61000-3-3 (1995)     | <input checked="" type="checkbox"/> IEC 61000-4-4 (2004)  |
| <input checked="" type="checkbox"/> + A1 (2001)             | <input checked="" type="checkbox"/> IEC 61000-4-5 (2001)  |
|   | <input checked="" type="checkbox"/> IEC 61000-4-6 (2003)  |
|   | <input checked="" type="checkbox"/> + A1 (2004)           |
|   | <input checked="" type="checkbox"/> IEC 61000-4-8 (2001)  |
|   | <input checked="" type="checkbox"/> IEC 61000-4-11 (2004) |

following the provisions of 89/336/EEC Directive

Place: \_\_\_\_\_ Signature: \_\_\_\_\_

Date : \_\_\_\_\_ Full name: \_\_\_\_\_



Title: \_\_\_\_\_

TÜV Rheinland Taiwan Ltd.



# Certificate of Appointment

for the applicant:

**Hometek Technology Inc.**  
No. 67-9, Shir Men Rd., Tu-Cheng City,  
Taipei Hsien 236, Taiwan, R.O.C.

has been authorized to carry out EMC tests by order and under supervision of TÜV Rheinland. It has successfully demonstrated capability to conduct measurement and to process test data according to:

**European and International EMC Standards as listed in the  
Scope of Authorization on the attachment to this certificate**

An assessment of the facility was conducted by TÜV Rheinland auditors according to the TÜV Rheinland requirements for "Test Site Approval" with reference to  
**ISO 17 025:1999**

Certificate No. : 10012161-2004

Valid until : February 14, 2006

TÜV Rheinland Taiwan Ltd.  
Taipei, December 21, 2004

  
Dipl.-Ing. Andreas Klinker  
Certification Body

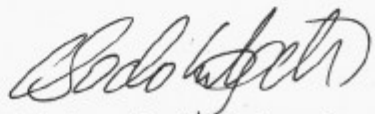
  
Dipl.-Ing. Bodo Kretzschmar  
Product Safety and Quality



Attachment to  
**Certificate**  
of Appointment

SCOPE OF AUTHORIZATION

**Hometek Technology Inc.**  
No. 67-9, Shir Men Rd., Tu-Cheng City,  
Taipei Hsien 236, Taiwan, R.O.C.

**European Standards**

EN 50081-1	EN 61000-3-2	ENV 50140
EN 50081-2	EN 61000-3-3	ENV 50141
EN 50082-1	EN 61000-6-1	ENV 50204
EN 50130-4	EN 61000-6-2	
EN 50091-2	EN 61000-6-3	
EN 55011	EN 61000-6-4	
EN 55013	EN 61000-3-11	
EN 55014-1	EN 61000-4-2	
EN 55014-2	EN 61000-4-3	
EN 55022	EN 61000-4-4	
EN 55024	EN 61000-4-5	
EN 60601-1-2	EN 61000-4-6	
EN 60801	EN 61000-4-8	
EN 60945	EN 61000-4-11	
	EN 61204-3	

**International Standards**

CISPR 11	IEC 61000-4-2	IEC 61000-3-2
CISPR 13	IEC 61000-4-3	IEC 61000-3-3
CISPR 14-1	IEC 61000-4-4	IEC 61000-3-11
CISPR 14-2	IEC 61000-4-5	IEC 61000-6-1
CISPR 22	IEC 61000-4-6	IEC 61000-6-2
CISPR 24	IEC 61000-4-8	IEC 61000-6-3
	IEC 61000-4-11	IEC 61000-6-4
IEC 801.2	IEC 61000-4-12	IEC 60945
IEC 801.3		
IEC 801.4		

Certificate No. : 10012161-2004

Taipei, December 21 , 2004

Dipl.-Ing. Bodo Krätzschar  
Product Safety and Quality