

HomeTek Technology Inc.

ADDRESS: No. 67-9, Shir Men Road, Tu Cheng City,  
Taipei Hsien

PHONE : 886-2-22608375 FAX : 886-2-22748013

E - mail : hometek@ms15.hinet.net

# CERTIFICATE OF COMPLIANCE

EUT : Power Center

MODEL NO. : PR8XXX

Receipt Date : 06/15/2006 Final Test Date: 07/04/2006

REPORT # : EB5F021

APPLICANT : SMART CABLING & TRANSMISSION CORP.

ADDRESS : 10F, No. 493, Chung-Cheng Rd.,  
Hsin Tien City, Taipei 231, Taiwan, R. O. C.

Measurement procedure used:

**EMI: EN 55022 Class B (1998) + A1 (2000) + A2 (2003),**

**EN 61000-3-2 (2000), EN 61000-3-3 (1995) + A1 (2001)**

**EMS: EN 55024 (1998) + A1 (2001) + A2 (2003):**

**IEC 61000-4-2 (2001), IEC 61000-4-3 (2002), IEC 61000-4-4 (2004), IEC 61000-4-5 (2001),**

**IEC 61000-4-6 (2003) + A1 (2004), IEC 61000-4-8 (2001), IEC 61000-4-11 (2004)**

We hereby show that:

The measurements shown in this test report were made in accordance with the procedures given in **EUROPEAN COUNCIL DIRECTIVE 89/336/EEC**, and the energy emitted by the equipment was found to be within the limits applicable.

This test result of this report applies to above tested sample only.

This test report shall not be reproduce in part without written approval of HomeTek Technology Inc.

APPROVED BY :  7/17/2006

ALAIN LIN / Supervisor



**TABLE OF CONTENTS..... 1**

**GENERAL INFORMATION..... 4**

**MODIFICATION LIST..... 6**

**CONDUCTED POWER LINE TEST ..... 7**

1 TEST INSTRUMENTS & FACILITIES..... 7

2 TEST PROCEDURE..... 7

3 TEST SETUP ..... 8

4 CONFIGURATION OF THE EUT ..... 10

5 EUT OPERATING CONDITION..... 12

6 LIMIT OF CONDUCTED POWER LINE EMISSION CLASS B..... 12

7 RESULT OF CONDUCTED POWER LINE TEST..... 12

8 CONDUCTED POWER LINE TEST DATA (PAGE 1)..... 13

9 CONDUCTED POWER LINE TEST DATA (PAGE 2)..... 14

10 CONDUCTED POWER LINE TEST DATA (PAGE 3)..... 15

11 CONDUCTED POWER LINE TEST DATA (PAGE 4)..... 16

**RADIATED EMISSION TEST..... 17**

1 TEST INSTRUMENTS & FACILITIES..... 17

2 TEST PROCEDURE..... 18

3 TEST SETUP ..... 18

4 CONFIGURATION OF THE EUT ..... 20

5 EUT OPERATING CONDITION..... 20

6 LIMIT OF RADIATED EMISSION CLASS B ..... 20

7 RESULT OF RADIATED EMISSION TEST..... 20

8 RADIATED EMISSION TEST DATA (PAGE 1)..... 21

9 RADIATED EMISSION TEST DATA (PAGE 2)..... 22

**HARMONICS TEST..... 23**

1 TEST INSTRUMENTS & FACILITIES..... 23

2 TEST PROCEDURE..... 23

3 TEST SETUP ..... 23

4 CONFIGURATION OF THE EUT ..... 23

5 OPERATION CONDITION OF EUT..... 23

6 TEST DATA & LIMIT..... 23

7 PHOTOS OF TEST CONFIGURATION PLEASE REFER TO APPENDIX A..... 23

8 HARMONICS TEST DATA (PAGE 1~2)..... 24

**VOLTAGE FLUCTUATIONS TEST ..... 26**

1 TEST INSTRUMENTS & FACILITIES..... 26

2 TEST PROCEDURE..... 26

3 TEST SETUP ..... 26



4 CONFIGURATION OF THE EUT ..... 26

5 OPERATION CONDITION OF EUT ..... 26

6 TEST DATA & LIMIT ..... 26

7 PHOTOS OF TEST CONFIGURATION PLEASE REFER TO APPENDIX A ..... 26

8 VOLTAGE FLUCTUATIONS TEST DATA (PAGE 1) ..... 27

**ELECTROSTATIC DISCHARGE IMMUNITY TEST (ESD) ..... 28**

1 TEST INSTRUMENTS & FACILITIES ..... 28

2 TEST PROCEDURE ..... 28

3 TEST SETUP ..... 28

4 CONFIGURATION OF THE EUT ..... 29

5 EUT OPERATION CONDITION ..... 29

6 TEST CONDITION ..... 29

7 PERFORMANCE CRITERIA ..... 29

8 TEST RESULT ..... 30

**RADIO FREQUENCY ELECTROMAGNETIC FIELD IMMUNITY TEST (RF) ..... 31**

1 TEST INSTRUMENTS & FACILITIES ..... 31

2 TEST PROCEDURE ..... 31

3 TEST SETUP ..... 32

4 CONFIGURATION OF THE EUT ..... 33

5 OPERATION CONDITION OF EUT ..... 33

6 TEST CONDITION ..... 33

7 PERFORMANCE CRITERIA ..... 33

8 TEST RESULT ..... 34

**ELECTRICAL FAST TRANSIENT/BURST IMMUNITY TEST (EFT) ..... 35**

1 TEST INSTRUMENTS & FACILITIES ..... 35

2 TEST PROCEDURE ..... 35

3 TEST SETUP ..... 35

4 CONFIGURATION OF THE EUT ..... 36

5 OPERATION CONDITION OF EUT ..... 36

6 TEST CONDITION ..... 36

7 PERFORMANCE CRITERIA ..... 36

8 TEST RESULT ..... 37

**SURGE IMMUNITY TEST ..... 38**

1 TEST INSTRUMENTS & FACILITIES ..... 38

2 TEST PROCEDURE ..... 38

3 TEST SETUP ..... 38

4 TEST LEVELS ..... 39

5 CONFIGURATION OF THE EUT ..... 39

6 EUT OPERATION CONDITION ..... 39



7 CONDITIONS DURING TESTING..... 39

8 PERFORMANCE CRITERIA ..... 40

9 TEST RESULT ..... 40

**IMMUNITY TEST TO CS CONDUCTED DISTURBANCE ..... 41**

1 TEST INSTRUMENTS & FACILITIES..... 41

2 TEST PROCEDURE..... 41

3 TEST SETUP ..... 42

4 TEST LEVELS..... 43

5 CONFIGURATION OF THE EUT ..... 43

6 EUT OPERATION CONDITION..... 43

7 CONDITIONS DURING TESTING..... 43

8 PERFORMANCE CRITERIA ..... 44

9 TEST RESULT ..... 44

**POWER FREQUENCY MAGNETIC FIELD IMMUNITY TEST ..... 45**

1 TEST INSTRUMENTS & FACILITIES..... 45

2 TEST STANDARD..... 45

3 TEST SETUP ..... 45

4 TEST LEVELS..... 46

5 CONFIGURATION OF THE EUT ..... 46

6 OPERATION CONDITION OF EUT..... 46

7 CONDITIONS DURING TESTING..... 46

8 PERFORMANCE CRITERIA ..... 46

9 TEST RESULTS ..... 47

**VOLTAGE DIPS, SHORT INTERRUPTIONS IMMUNITY TEST..... 48**

1 TEST INSTRUMENTS & FACILITIES..... 48

2 TEST PROCEDURE..... 48

3 TEST SETUP ..... 48

4 TEST LEVELS..... 49

5 CONFIGURATION OF THE EUT ..... 49

6 EUT OPERATION CONDITION..... 49

7 CONDITIONS DURING TESTING..... 49

8 PERFORMANCE CRITERIA ..... 50

9 TEST RESULT ..... 50

**APPENDIX A**

PHOTOS OF TEST CONFIGURATION

**APPENDIX B**

PHOTOS OF EUT

**GENERAL INFORMATION**

- 1 APPLICANT : SMART CABLING & TRANSMISSION CORP.
- 2 ADDRESS : 10F, No. 493, Chung-Cheng Rd.,  
Hsin Tien City, Taipei 231, Taiwan, R. O. C.
- 3 MANUFACTURER : SMART CABLING & TRANSMISSION CORP.
- 4 ADDRESS : 10F, No. 493, Chung-Cheng Rd.,  
Hsin Tien City, Taipei 231, Taiwan, R. O. C.
- 5 DESCRIPTION OF EUT :
- EUT : Power Center
- Model : PR8XXX
- Serial # : N/A

5.1 The difference between series of models PR8XXX are as shown below:

**P R 8 X X X**

- (1) The first and second “X” represent different system input.
- (2) The last “X” represent different accessory.

The PCB layout is similar. The worst case of model is PR816, and the final test data were shown in this test report.

## 6 FEATURES OF EUT :

**Please refer to user manual or product specification.**

## 7 TEST MODE :

The EUT were investigated with two operation modes shown as below :

- (1) Full Load Mode;
- (2) Half Load Mode

The test mode of (1) Full Load Mode is worst case, and the final test data were shown in this test report.

## **MODIFICATION LIST**

**THE FOLLOWING ACCESSORIES WERE ADDED TO THE EUT DURING TESTING :**

**NO MODIFICATION BY HOMETEK TECHNOLOGY INC.**

## CONDUCTED POWER LINE TEST

### 1 TEST INSTRUMENTS & FACILITIES

The following test Instruments was used during the conducted test :

Item	Instruments/ Facilities	Specification	Manufacturer	Model #	Date Of Cal.
1	EMI Receiver	9KHz ~ 30MHz	ROHDE & SCHWARZ	ESHS 30 844827/007	FEB/2006
2	LISN (for EUT)	50Ω/50uH/100A 150KHz ~ 30MHz	SCHWARZ BECK	NNLK 8121 8121370	OCT/2005
3	LISN (for Support Unit)	50Ω/50uH/10A 9KHz ~ 30MHz	ROHDE & SCHWARZ	ESH3-Z5 846128/007	MAR/2006
4	Terminator	50Ω	N/A	N/A	NOV/2005
5	Attenuation	50Ω/10dB	Mini-Circuit	NAT-10 AT-002	JUL/2005
6	Cable	5.4m	SUHNER	RG-223 CON2-002	AUG/2005
7	ESXS-K1 (software)	Version 2.03b 9KHz ~ 30MHz	ROHDE & SCHWARZ	1082.9678.02 840.913/246	N/A

Note : Items 1 ~ 6 were calibrated within period of 1 year.

### 2 TEST PROCEDURE

- 2.1 The EUT was tested according to **EN55022 Class B**.
- 2.2 The EUT was placed 0.4 meter from the conducting wall of shielding room and kept at least 0.8 meter from any other grounded conducting surface.
- 2.3 The frequency range form 0.15 MHz to 30 MHz was investigated.
- 2.4 The LISN used was 50 Ohm / 50 uHenry as specified by **EN55022**.
- 2.5 All the support peripherals are connect to the other LISN.
- 2.6 Cables and peripherals were moved to find the maximum emission levels for each frequency.

### 3 TEST SETUP

#### 3.1 Typical : Setup Of Conducted Test

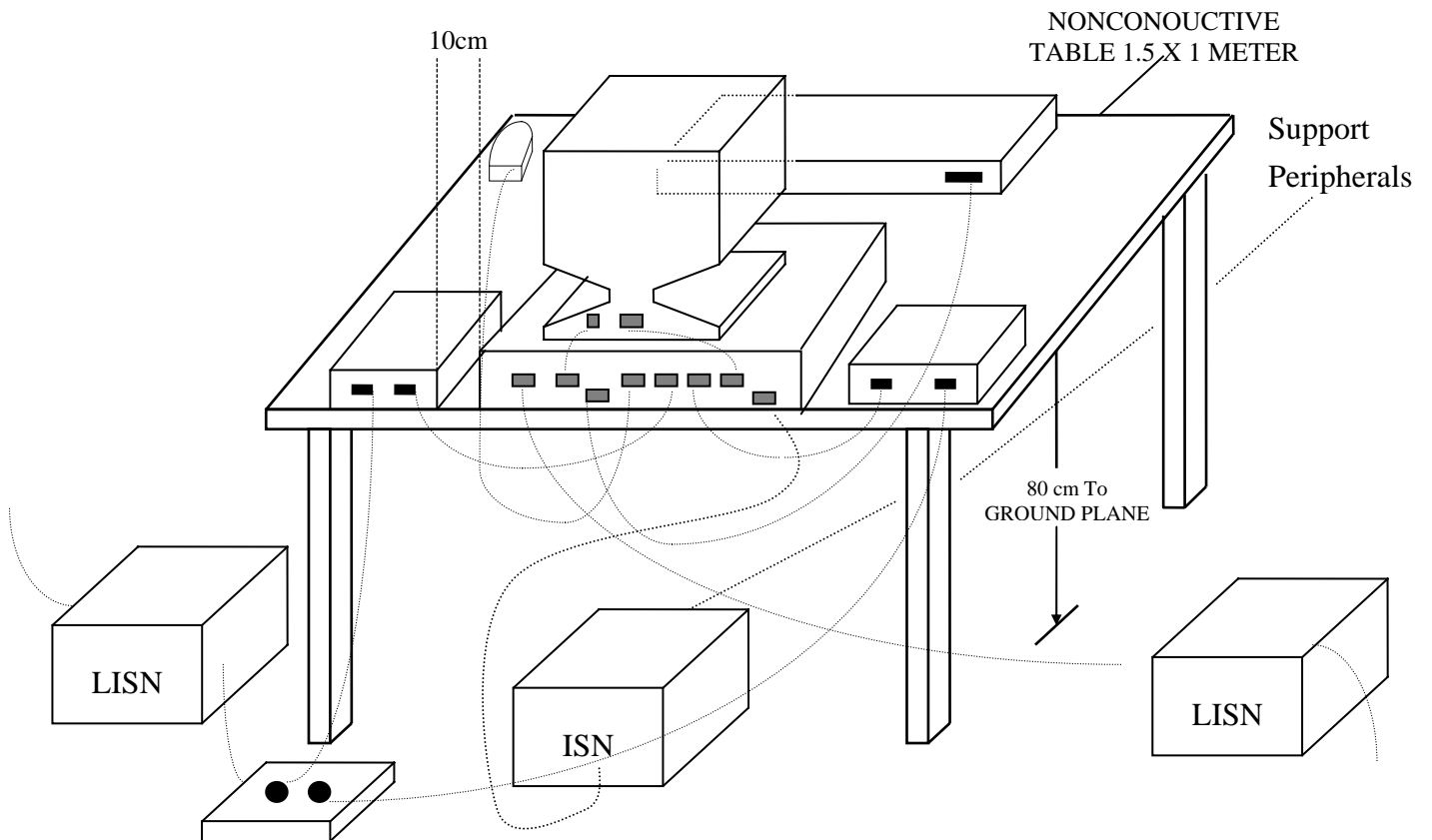

(Details for setup configuration, please refer to appendix A.)

### 3.2 Block Diagram Of Conducted Test

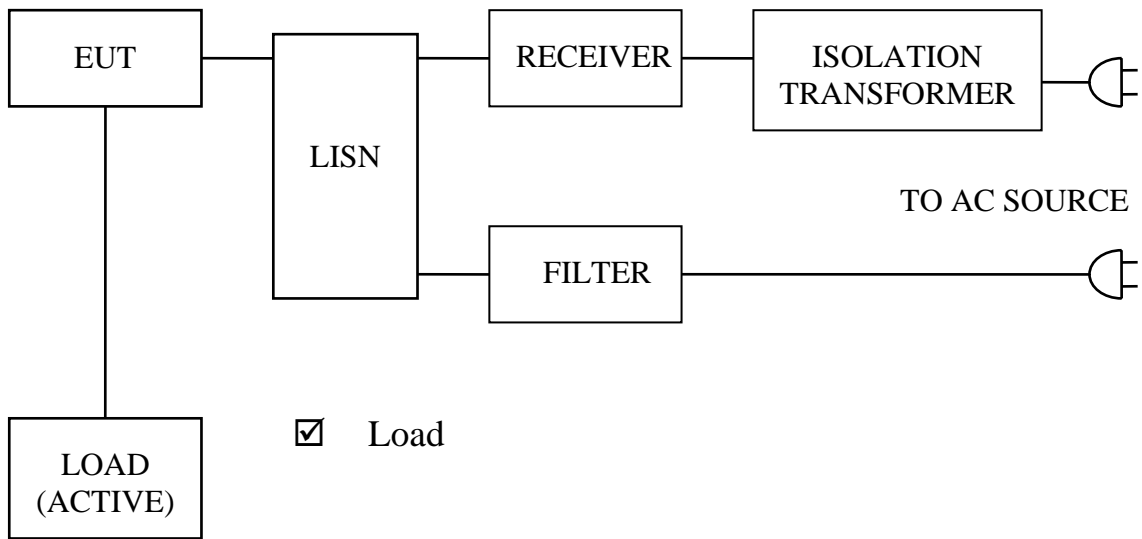



#### 4 CONFIGURATION OF THE EUT

The EUT was configured according to **EN55022**. All I/O ports were connected to the appropriate peripherals. All peripherals and cables are listed below (including internal device) :

##### 4.1 EUT

EUT Type : Proto Type Engineer Type Mass Production  
Condition when received : Good Damage : \_\_\_\_\_  
Device : Power Center  
Applicant : SMART CABLING & TRANSMISSION CORP.  
Manufacturer : SMART CABLING & TRANSMISSION CORP.  
Model Number : PR8XXX  
Serial Number : N/A  
FCC ID : N/A  
Data Cable : N/A  
Power Cord (AC) Input : Un-Shielded, 1.8 m, 3 pin  
Power Cord (AC) Output : Un-Shielded, 1.0 m, 2 pin  
Power Supply Type : Linear

##### 4.2 PERIPHERALS

Full Load  
Manufacturer : HomeTek  
Specification : 3Ω/24V  
Power Cord : Un-Shielded, 1.0 m



HomeTek Technology Inc.

Half Load

Manufacturer : HomeTek

Specification :  $6\Omega/24V$

Power Cord : Un-Shielded, 1.0 m

4.3 REMARK : N/A

## 5 EUT OPERATING CONDITION

- 5.1 The frequency of the EUT is none.
- 5.2 Configure the EUT according to the **EN 55022 Class B**.
- 5.3 Install the appropriate Load.
- 5.4 Performance the EMI testing procedures, and measure the maximum emission noise.
- 5.5 **The photos of conducted test configuration, please refer to appendix A.**

## 6 LIMIT OF CONDUCTED POWER LINE EMISSION CLASS B

Frequency Range	Quasi Peak	Average
0.15 ~ 0.5 MHz	66 - 56 dBuV	56 - 46 dBuV
0.5 ~ 5 MHz	56 dBuV	46 dBuV
5 ~ 30 MHz	60 dBuV	50 dBuV

## 7 RESULT OF CONDUCTED POWER LINE TEST

- 7.1 The frequency range from 0.15 MHz to 30 MHz was investigated. All readings are quasi-peak values and average.
- 7.2 IF bandwidth : 9 kHz, Meas Time : 1 sec.
- 7.3 Temperature : 28 °C, Humidity : 55 % RH.
- 7.4 Deviations from the test standards and rules : None.
- 7.5 The conducted test result were gained by following procedures :  
 Level = Reading Level + Insertion Loss of LISN + Cable Loss  
 (All calculation were done by ESHS30 EMI test receiver.)
- 7.6 Result : **PASSED**

## 8 CONDUCTED POWER LINE TEST DATA (PAGE 1)

HomeTek EMC LAB. TEL :886-2-22608375

04 Jul 2006 14:10

### CONDUCTED EMISSIONS

EUT: Power Center  
 Manuf: 5F021  
 Op Cond: LINE 1  
 Operator: Makoto  
 Test Spec: FOR EN55022 CLASS B  
 Comment: 230V/50Hz  
 PR816 (Full Load)  
 Result File: 5f02112c.dat : FULL LOAD

Prescan Measurement: Detectors: X PK / + AV  
 Meas Time: see scan settings  
 Subranges: 16  
 Acc Margin: 55 dB

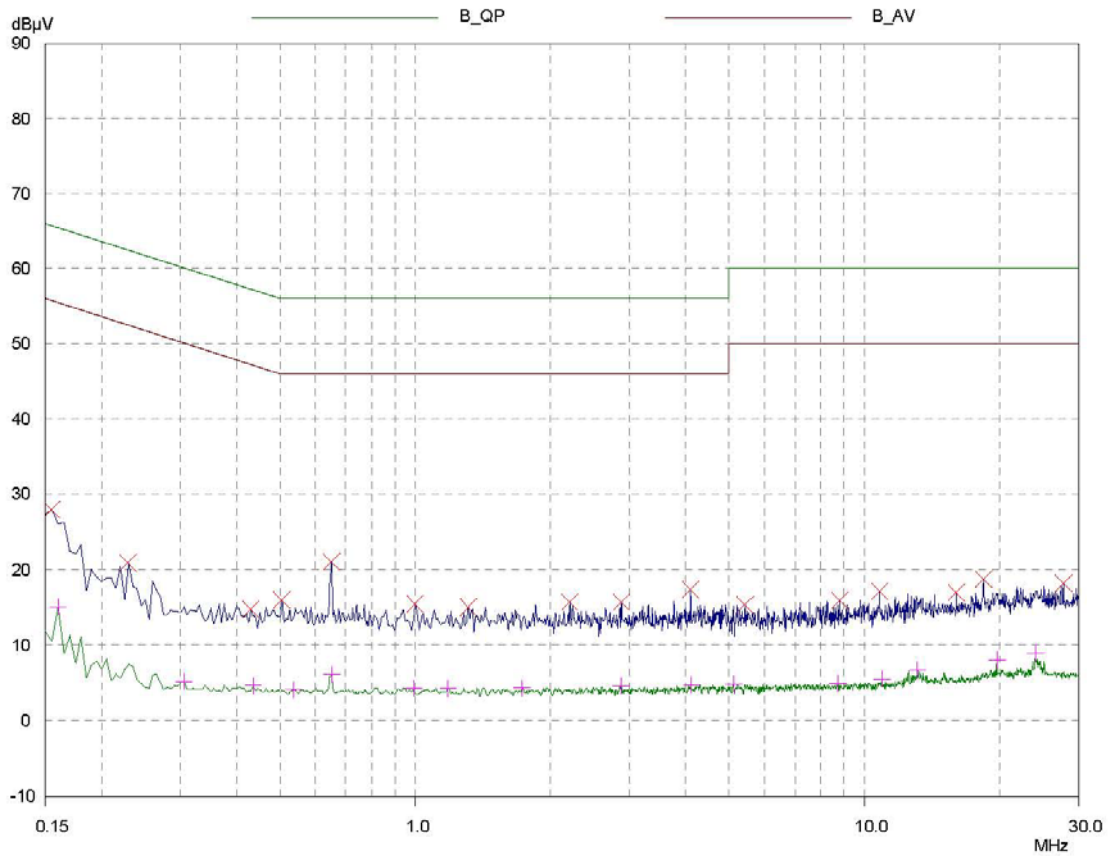



### 9 CONDUCTED POWER LINE TEST DATA (PAGE 2)

HomeTek EMC LAB. TEL :886-2-22608375

04 Jul 2006 14:10

#### CONDUCTED EMISSIONS

EUT: Power Center  
 Manuf: 5F021  
 Op Cond: LINE 1  
 Operator: Makoto  
 Test Spec: FOR EN55022 CLASS B  
 Comment: 230V/50Hz  
 PR816 (Full Load)  
 Result File: 5f02112c.dat : FULL LOAD

Prescan Measurement: Detectors: X PK / + AV  
 Meas Time: see scan settings  
 Subranges: 16  
 Acc Margin: 55 dB

#### Peak Search Results

Frequency MHz	PK Level dBµV	PK Limit dBµV	PK Delta dB
0.155	27.88	65.73	37.85
0.23	20.90	62.45	41.55
0.43	14.72	57.25	42.53
0.505	15.97	56.00	40.03
0.65	21.05	56.00	34.95
1.0	15.45	56.00	40.55
1.31	15.01	56.00	40.99
2.21	15.71	56.00	40.29
2.88	15.69	56.00	40.31
4.09999	17.36	56.00	38.64
5.42	15.32	60.00	44.68
8.8	15.95	60.00	44.05
10.79	17.10	60.00	42.90
16.0	16.98	60.00	43.02
18.41	18.73	60.00	41.27
27.77	18.19	60.00	41.81

Frequency MHz	AV Level dBµV	AV Limit dBµV	AV Delta dB
0.16	15.03	55.46	40.43
0.305	5.22	50.11	44.89
0.435	4.67	47.16	42.49
0.535	4.13	46.00	41.87
0.65	6.13	46.00	39.87
0.99	4.35	46.00	41.65
1.18	4.31	46.00	41.69
1.73	4.38	46.00	41.62
2.87	4.63	46.00	41.37
4.11	4.78	46.00	41.22
5.1	4.87	50.00	45.13
8.73	4.98	50.00	45.02
10.93	5.50	50.00	44.50
13.1	6.73	50.00	43.27
19.71	8.08	50.00	41.92
24.0	8.89	50.00	41.11

\* limit exceeded



### 10 CONDUCTED POWER LINE TEST DATA (PAGE 3)

HomeTek EMC LAB. TEL :886-2-22608375

04 Jul 2006 14:06

#### CONDUCTED EMISSIONS

EUT: Power Center  
Manuf: 5F021  
Op Cond: LINE 2  
Operator: Makoto  
Test Spec: FOR EN55022 CLASS B  
Comment: 230V/50Hz  
PR816 (Full Load)  
Result File: 5f02122c.dat : FULL LOAD

Prescan Measurement:      Detectors:      X PK / + AV  
                                 Meas Time:      see scan settings  
                                 Subranges:      16  
                                 Acc Margin:      55 dB

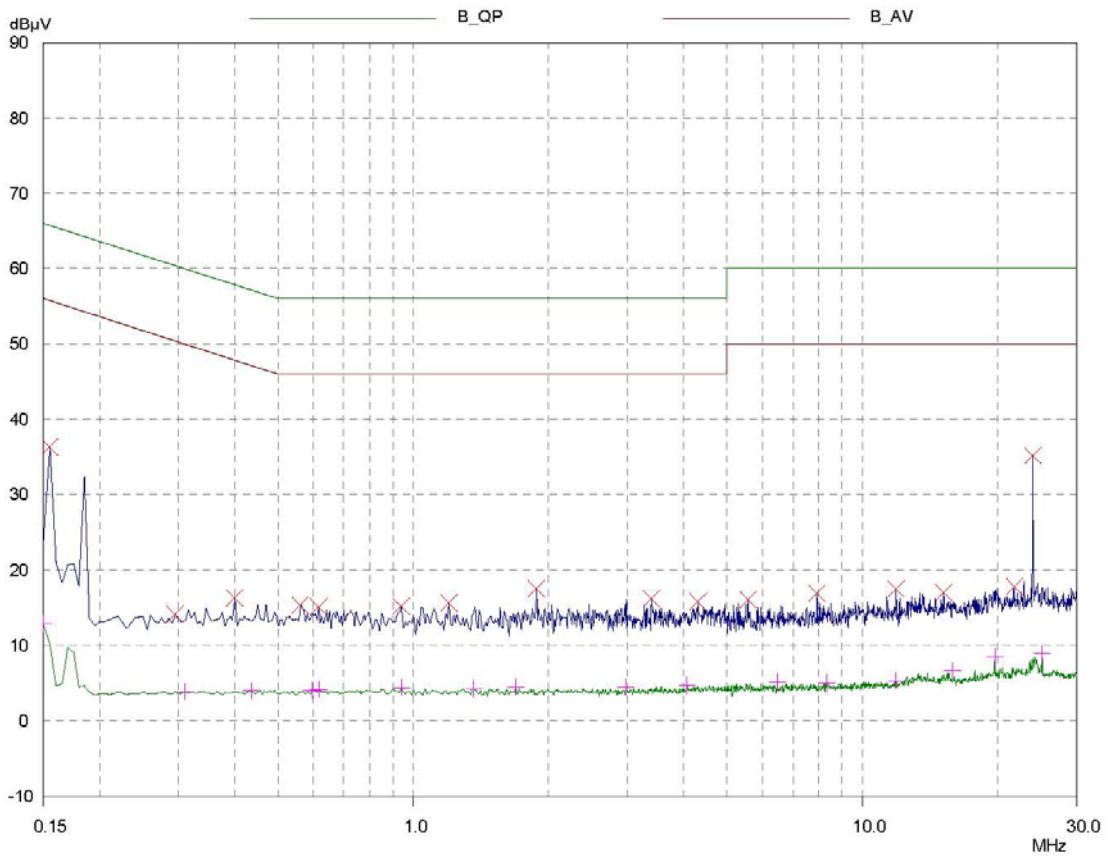



# 11 CONDUCTED POWER LINE TEST DATA (PAGE 4)

HomeTek EMC LAB. TEL :886-2-22608375

04 Jul 2006 14:06

## CONDUCTED EMISSIONS

EUT: Power Center  
 Manuf: 5F021  
 Op Cond: LINE 2  
 Operator: Makoto  
 Test Spec: FOR EN55022 CLASS B  
 Comment: 230V/50Hz  
 PR816 (Full Load)  
 Result File: 5f02122c.dat : FULL LOAD

Prescan Measurement: Detectors: X PK / + AV  
 Meas Time: see scan settings  
 Subranges: 16  
 Acc Margin: 55 dB

### Peak Search Results

Frequency MHz	PK Level dBµV	PK Limit dBµV	PK Delta dB
0.155	36.32	65.73	29.41
0.295	14.16	60.38	46.22
0.4	16.29	57.85	41.56
0.56	15.37	56.00	40.63
0.615	15.15	56.00	40.85
0.94	15.18	56.00	40.82
1.2	15.61	56.00	40.39
1.88	17.55	56.00	38.45
3.39	16.23	56.00	39.77
4.3	15.75	56.00	40.25
5.56	16.06	60.00	43.94
7.91	16.89	60.00	43.11
11.87	17.45	60.00	42.55
15.14	17.03	60.00	42.97
21.75	17.80	60.00	42.20
23.94	35.20	60.00	24.80

Frequency MHz	AV Level dBµV	AV Limit dBµV	AV Delta dB
0.15	12.92	56.00	43.08
0.31	3.91	49.97	46.06
0.435	4.01	47.16	43.15
0.595	4.07	46.00	41.93
0.615	4.17	46.00	41.83
0.94	4.41	46.00	41.59
1.36	4.30	46.00	41.70
1.69	4.48	46.00	41.52
2.87	4.53	46.00	41.47
4.05999	4.72	46.00	41.28
6.47	5.13	50.00	44.87
8.31	5.05	50.00	44.95
11.87	5.31	50.00	44.69
15.88	6.65	50.00	43.35
19.71	8.51	50.00	41.49
25.11	8.85	50.00	41.15

\* limit exceeded

## RADIATED EMISSION TEST

### 1 TEST INSTRUMENTS & FACILITIES

The following test Instruments was used during the radiated emission test :

Item	Instruments /facilities	Specification	Manufacturer	Model # / S/N#	Date of Cal.
1	OPEN AREA TEST SITE	<input checked="" type="checkbox"/> OATS 3			JUL/2005
2	EMI TEST RECEIVER	20Hz ~ 26.5GHz	ROHDE & SCHWARZ	ESMI 845442/006	FEB/2006
3	PRE-AMPLIFIER	9KHz ~ 3000MHz	ADVANTEST	BB525C 90081001	OCT/2005
4	ANTENNA (BI-LOG)	25MHz ~ 2GHz	SCHAFFNER	CBL6112B S/N : 2614	JUN/2006
5	Attenuation	50Ω/6dB	JYE BAO	FAT-N (M-F) 001	JUL/2005
6	Ferrite Clamp	30 ~ 1000MHz	ADT	FC18 910030	DEC/2005
7	Ferrite Clamp	30 ~ 1000MHz	HomeTek	HFC 001	DEC/2005
8	Cable	10m	SUHNER	RG214/U OS3-003	DEC/2005
9	Cable	14m	BELDEN	9913 OS3-001	DEC/2005
10	EMI 32 (software)	N/A	AUDIX	19991013-0923	N/A

Note : Items 1 ~ 9 were calibrated within period of 1 year.

## 2 TEST PROCEDURE

- 2.1 The EUT was test according to **EN55022**.
- 2.2 The radiated test was performed at HomeTek Lab's Open Site III.
- 2.3 The frequency range from 30 MHz to 1 GHz, the measurement were made at 10 meters, with a BI-log antenna.

## 3 TEST SETUP

### 3.1 TEST SETUP OF OPEN SITE.

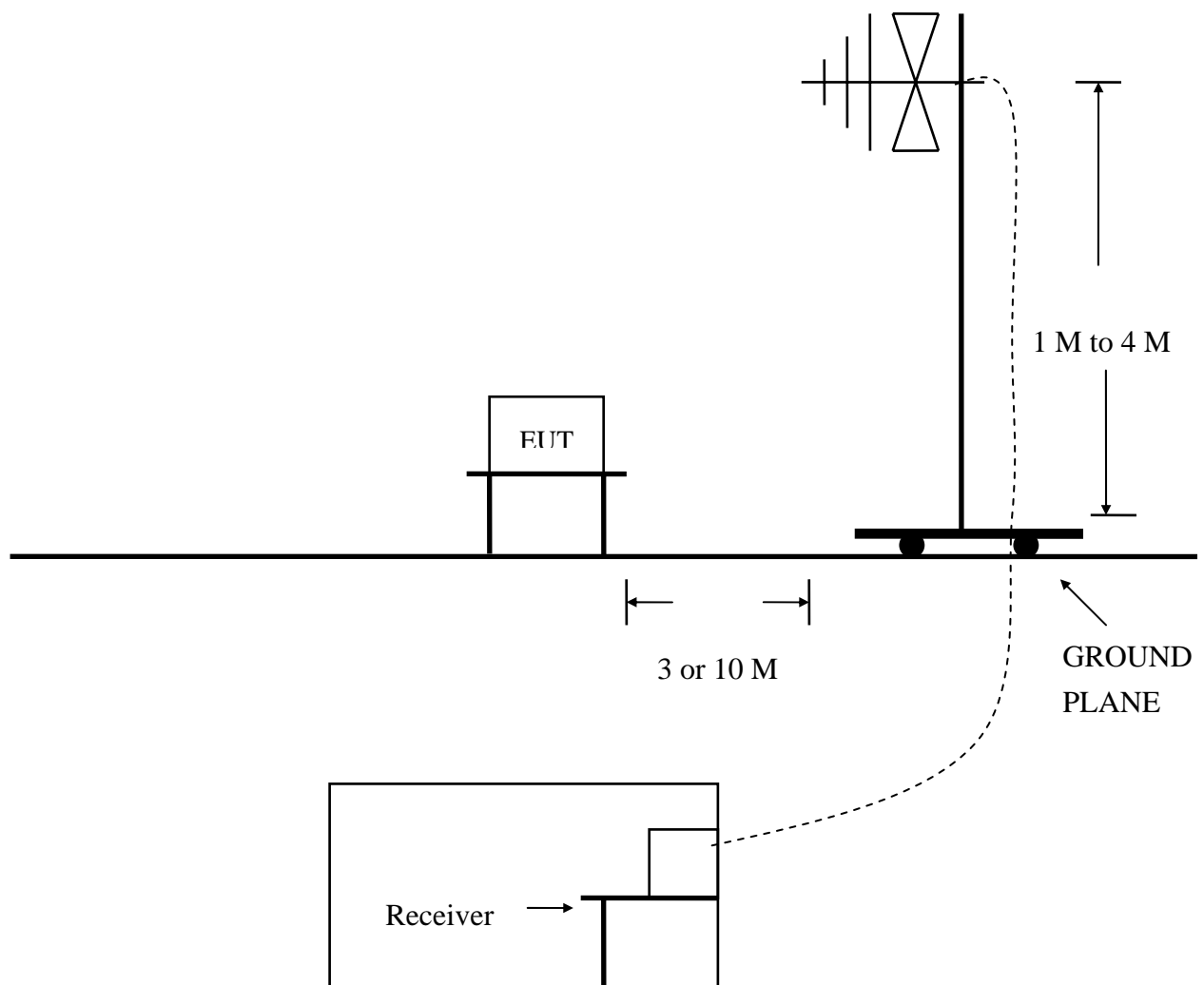

(Details for setup configuration, please refer to appendix A.)

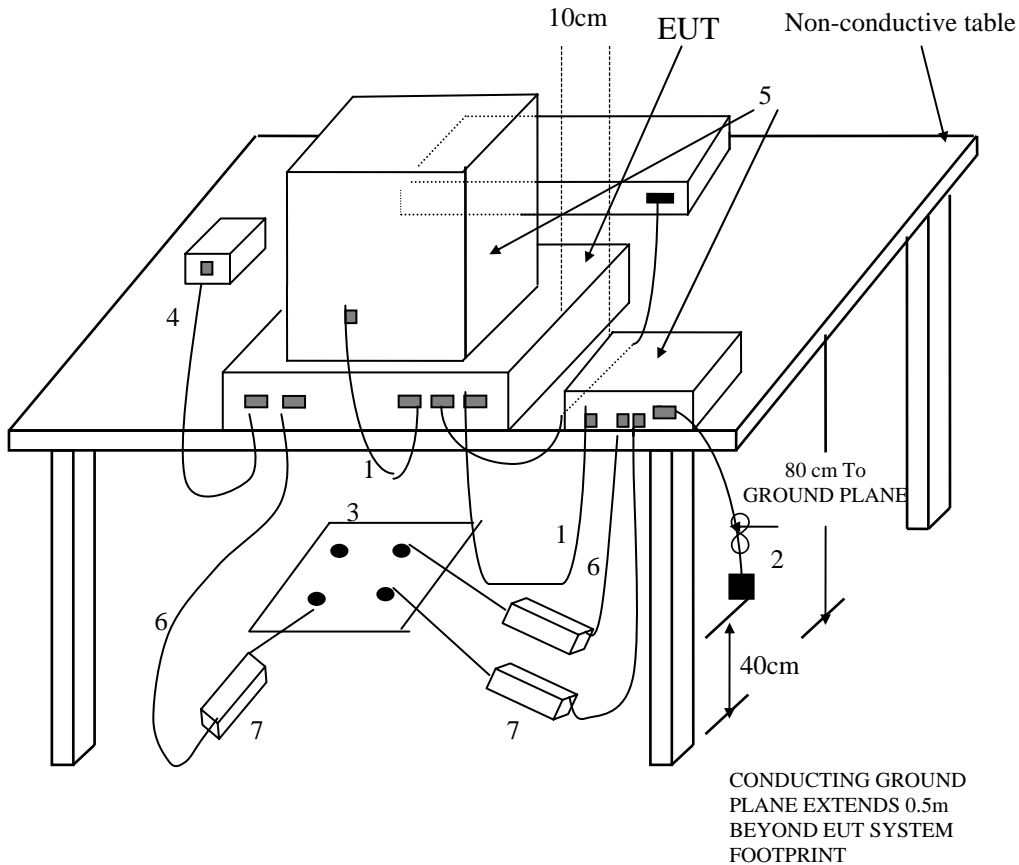

(Details for setup configuration, please refer to appendix A.)

**LEGEND:**

- 1.If cables, which hang closer than 40 cm to the horizontal metal ground plane cannot be shortened to the appropriate length, the excess shall be folded back and forth forming a bundle 30 m to 40 cm long.
- 2.The end of I/O signal cables which are not connected to a peripheral may be terminated, if required for proper operation using correct terminating impedance.
- 3.Mains junction box(es) shall be flush with, and bonded directly to , the metal ground plane.  
NOTE if used, the AMN shall be installed under the horizontal metal ground plane.
- 4.Cables of hand-operated devices such as keyboards, mice, etc. shall be placed as for normal usage.
- 5.Peripherals shall be placed at a distance of 10 cm from each other and from the controller, except for the monitor which, if for an acceptable installation practice, shall be placed directly on top of the controller.
- 6.Mains cables, telephone lines or other connections to auxiliary equipment located outside the test area shall drape to the floor, be fitted with ferrite clamps or ferrite tubes placed on the floor at the point where the cable reaches the floor and then routed to the place where they leave the turntable. No extension cords shall be used to mains receptacle.
- 7.Ferrite clamps or ferrite tubes with similar characteristics (as defined in 10.4). No more than one cable per clamp.

**Test Configuration**  
**Tabletop Equipment Radiated Measurement**

4 CONFIGURATION OF THE EUT

Same as “Conducted Power Line test”, section 4

5 EUT OPERATING CONDITION

5.1 Same as “Conducted Power Line test”, section 5

5.2 The radiated emission in the frequency range from 30 MHz - 1000 MHz was test in a horizontal and vertical polarization at HomeTek Lab’s open site III.

**5.3 The photos of radiated test configuration, please refer to appendix A.**

6 LIMIT OF RADIATED EMISSION CLASS B

Frequency (MHz)	Measurement Distance	Limit (dBuV/m)
30 - 230	10 (M)	30
230 - 1000	10 (M)	37

7 RESULT OF RADIATED EMISSION TEST

7.1 The frequency range from 30 MHz to 1 GHz was investigated.

7.2 All readings below or equal 1 GHz are quasi-peak or peak values with resolution bandwidth of 120 KHz.

7.3 The measurements were made at 10 meters of HomeTek Lab’s open site III.

7.4 Temperature : 30 °C, Humidity : 60 % RH.

7.5 Deviation form the test standards and rules : None.

7.6 The radiated emission result were gained by the following method :

Level = Reading Level + Probe Factor (Antenna Factor) + Cable Loss – Preamp Factor

Over Limit = Level – Limit Line

7.7 Result : **PASSED**



# 8 RADIATED EMISSION TEST DATA (PAGE 1)



HomeTek Technology Inc.

No 67-9, Shi-Men Rd., Tu-Chen City,  
Taipei County, Taiwan R.O.C.  
Tel: 02-22608375  
Fax: 02-22748013

Data#: 6 File#: 5f021.EMI

Date: 2006-07-04 Time: 15:58:47

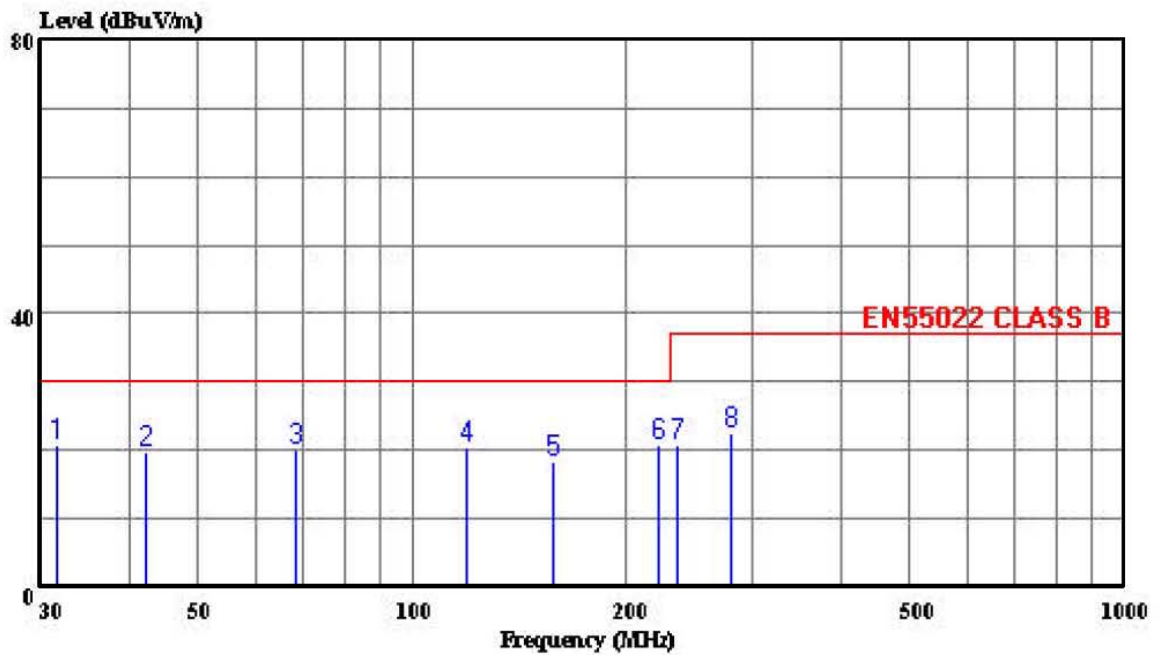

Trace:

Ref Trace:

Condition: EN55022 CLASS B 10m CHASE 2614 060506 HORIZONTAL  
cut : Power Center  
power: 230V/50Hz  
memo : PR816 (Full Load)

Page: 1

	Limit	Over	ReadAntenna	Cable	Preamp			
Freq	Level	Line	Limit	Level	Factor	Loss	Factor	Remark
MHz	dBuV/m	dBuV/m	dB	dBuV	dB/m	dB	dB	
1	31.560	20.88	30.00	-9.12	28.13	17.96	0.76	25.98 Peak
2	42.180	19.75	30.00	-10.25	31.53	13.30	0.87	25.95 Peak
3	68.740	20.11	30.00	-9.89	38.67	6.20	1.11	25.87 Peak
4	119.000	20.55	30.00	-9.45	32.44	12.38	1.49	25.75 Peak
5	157.413	18.27	30.00	-11.73	32.19	10.04	1.72	25.68 Peak
6	221.990	20.88	30.00	-9.12	34.91	9.50	2.07	25.60 Peak
7	235.710	20.94	37.00	-16.06	33.47	10.94	2.12	25.58 Peak
8	280.880	22.55	37.00	-14.45	32.90	12.90	2.29	25.54 Peak

9 RADIATED EMISSION TEST DATA (PAGE 2)



HomeTek Technology Inc.

No 67-9, Shi-Men Rd., Tu-Chen City,  
 Taipei County, Taiwan R.O.C.  
 Tel: 02-22608375  
 Fax: 02-22748013

Data#: 5 File#: 5f021.EMI

Date: 2006-07-04 Time: 15:31:17

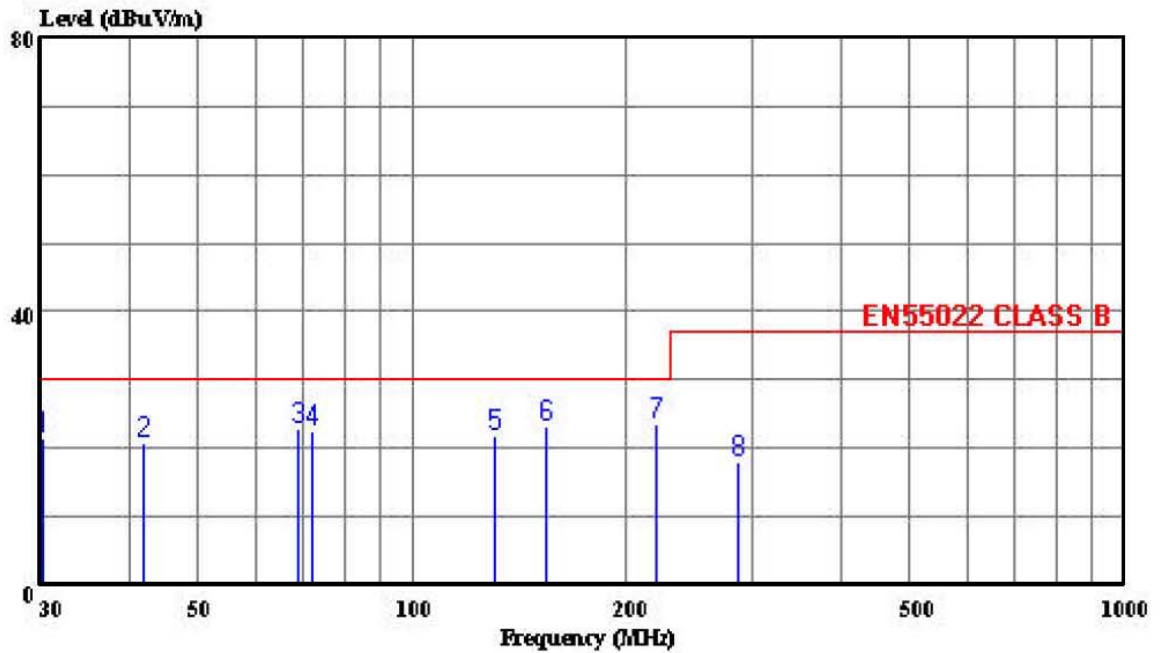

Trace:

Ref Trace:

Condition: EN55022 CLASS B 10m CHASE 2614 060506 VERTICAL  
 eut : Power Center  
 power: 230V/50Hz  
 memo : PR816 (Full Load)

Page: 1

	Freq	Level	Limit	Over	ReadAntenna	Cable	Preamp	Remark
	MHz	dBuV/m	dBuV/m	dB	Level	Loss	Factor	
					Factor			
					dB/m	dB	dB	
1	30.180	21.56	30.00	-8.44	28.22	18.58	0.74	25.98 Peak
2	41.970	20.85	30.00	-9.15	32.58	13.35	0.87	25.95 Peak
3	68.800	23.00	30.00	-7.00	41.54	6.22	1.11	25.87 Peak
4	72.110	22.44	30.00	-7.56	40.72	6.45	1.13	25.86 Peak
5	130.150	21.88	30.00	-8.12	34.56	11.50	1.55	25.73 Peak
6	153.600	23.22	30.00	-6.78	37.10	10.11	1.70	25.69 Peak
7	220.156	23.44	30.00	-6.56	37.75	9.23	2.06	25.60 Peak
8	286.770	17.91	37.00	-19.09	28.23	12.90	2.31	25.53 Peak

## HARMONICS TEST

### 1 TEST INSTRUMENTS & FACILITIES

Instruments/ facilities	Manufacturer	Model # Serial #	Date of Cal.
HARMONICS/ VOLTAGE FLUCTUATIONS TEST	EMC-PARTNER	HAR1000-1P	OCT/2004
CONTROL PC	KB TECH	KB P586/133	N/A

Note : Item 1 were calibrated with two years and verified before testing.

### 2 TEST PROCEDURE

According to EN 61000-3-2 (2000) Class A

### 3 TEST SETUP

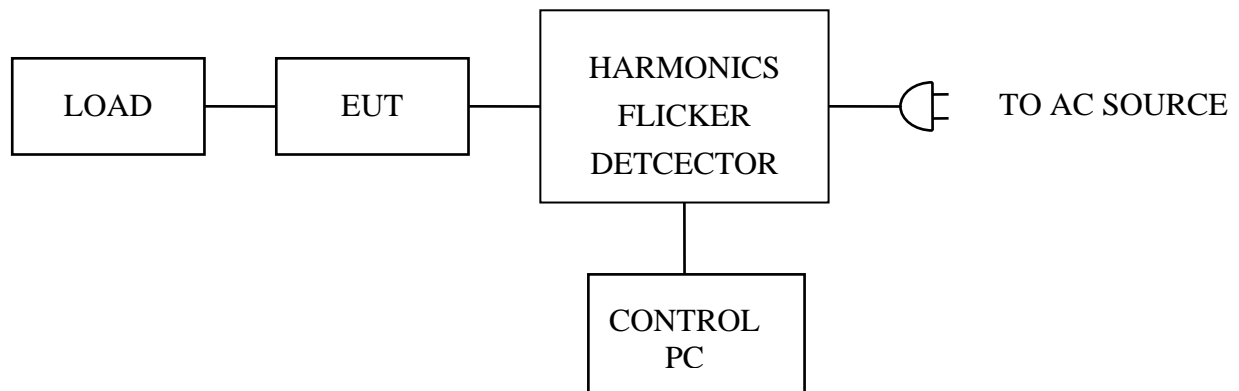

(Details for setup configuration, please refer to appendix A.)

### 4 CONFIGURATION OF THE EUT

Same as “Conducted Power Line test”, section 4

### 5 OPERATION CONDITION OF EUT

Same as “Conducted Power Line test”, section 5

### 6 TEST DATA & LIMIT

6.1 Temperature : 25 °C

6.2 Humidity : 60 % RH

### 7 Photos of test configuration please refer to appendix A.



8 HARMONICS TEST DATA (PAGE 1~2)

EMC PARTNER AG, SWITZERLAND

Date : 2006/7/4 PM 04:30:17 V4.14

Operator : Albert
Unit : Power Center
Serialnumber : PR816
Remarks : 5F021

Urms = 229.9V Freq = 49.987 Range: 5 A
Irms = 0.623A Ipk = 0.886A cf = 1.424
P = 142.2W S = 143.1VA pf = 0.994
THDi = 9.40 % THDu = 0.10 % Class A

Test - Time : 15min ( 100 %)

Test completed, Result: PASSED

Table with 5 columns: Order, Freq. [Hz], Imax [A], Imax%L [%], Limit [A]. Rows 1-25 showing harmonic test results.



## HomeTek Technology Inc.

26	13000.0000	0.0000	0.0708
27	13500.0000	0.0000	0.0833
28	14000.0000	0.0000	0.0657
29	14500.0000	0.0000	0.0776
30	15000.0000	0.0000	0.0613
31	15500.0000	0.0000	0.0726
32	16000.0000	0.0000	0.0575
33	16500.0000	0.0000	0.0682
34	17000.0000	0.0000	0.0541
35	17500.0000	0.0000	0.0643
36	18000.0000	0.0000	0.0511
37	18500.0000	0.0000	0.0608
38	19000.0000	0.0000	0.0484
39	19500.0000	0.0000	0.0577
40	20000.0000	0.0000	0.0460

## VOLTAGE FLUCTUATIONS TEST

### 1 TEST INSTRUMENTS & FACILITIES

Instruments/ facilities	Manufacturer	Model # Serial #	Date of Cal.
HARMONICS/ VOLTAGE FLUCTUATIONS TEST	EMC-PARTNER	HAR1000-1P	OCT/2004
CONTROL PC	KB TECH	KB P586/133	N/A

Note : Item 1 were calibrated with two years and verified before testing.

### 2 TEST PROCEDURE

According to **EN 61000-3-3 (1995) + A1 (2001)**

### 3 TEST SETUP

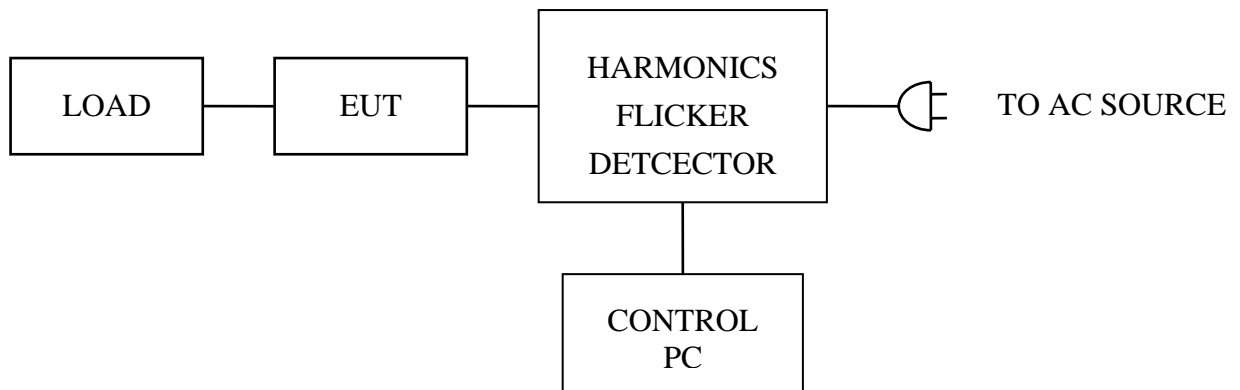

(Details for setup configuration, please refer to appendix A.)

### 4 CONFIGURATION OF THE EUT

Same as “Conducted Power Line test”, section 4

### 5 OPERATION CONDITION OF EUT

Same as “Conducted Power Line test”, section 5

### 6 TEST DATA & LIMIT

6.1 Temperature :  25  °C

6.2 Humidity :  60  % RH

### 7 Photos of test configuration please refer to appendix A.



8 VOLTAGE FLUCTUATIONS TEST DATA (PAGE 1)

EMC PARTNER AG, SWITZERLAND

Date : 2006/7/4 PM 04:48:44 V4.14

Operator : Albert  
 Unit : Power Center  
 Serialnumber : PR816  
 Remarks : 5F021

Urms = 229.7V Freq = 49.987 Range: 5 A  
 Irms = 0.623A Ipk = 0.894A cf = 1.435  
 P = 142.2W S = 143.0VA pf = 0.994

Test - Time : 1 x 15min = 15min ( 100 %)

LIN (Line Impedance Network) : L: 0.24ohm +j0.15ohm N: 0.16ohm +j0.10ohm

Limits :Plt : 0.65Pst : 1.00  
 dmax : 4.00 % dc : 3.30 %  
 dtLim: 3.30 % dt>Lim: 500ms

Test completed, Result: PASSED

Plt = 0.072

	Pst	dmax
		[%]
1	0.072	0.000



#### 4 CONFIGURATION OF THE EUT

Same as “Conducted Power Line test”, section 4

#### 5 EUT OPERATION CONDITION

Same as “Conducted Power Line test”, section 5

#### 6 TEST CONDITION

##### 6.1 Test Level :

(A)  $\pm 2, 4, 8$  KV for air discharge.

(B)  $\pm 2, 4$  KV for contact discharge.

##### 6.2 Number of test : 10 Discharges / Test point / Polarity / Level

Particular requirements : at least 200 discharges, 100 each at negative and positive polarity, at a minimum of four test points.

##### 6.3 Time between test : 1 sec.

##### 6.4 Temperature : 25 °C

##### 6.5 Humidity : 60 % RH.

#### 7 PERFORMANCE CRITERIA

- A. The apparatus shall continue to operate as intended during and after the test. No degradation of performance or loss of function is allowed below a performance level specified by the manufacturer, when the apparatus is used as intended.
- B. The apparatus shall continue to operate as intended after the test. No degradation of performance or loss of function is allowed below a performance level specified by the manufacturer, when the apparatus is used as intended. The performance level may be replaced by a permissible loss of performance. During the test, degradation of performance is however allowed.
- C. Temporary loss of function is allowed, provided the function is self-recoverable or can be restored by the operation of the controls.

## 8 TEST RESULT

Test Point	Air Discharge	Contact Discharge	Performance Criteria	Result
HCP	---	±2, 4KV	A	<b>PASSED</b>
VCP	---	±2, 4KV	A	<b>PASSED</b>
CASE	±2, 4, 8KV	±2, 4KV	A	<b>PASSED</b>
I/O PORTS	±2, 4, 8KV	±2, 4KV	A	<b>PASSED</b>
LED	±2, 4, 8KV	±2, 4KV	A	<b>PASSED</b>
SCREWS	±2, 4, 8KV	±2, 4KV	A	<b>PASSED</b>
AC SOCKET	±2, 4, 8KV	±2, 4KV	A	<b>PASSED</b>

## 9 Photos of test configuration please refer to appendix A.

## RADIO FREQUENCY ELECTROMAGNETIC FIELD IMMUNITY TEST (RS)

### 1 TEST INSTRUMENTS & FACILITIES

Item	Instruments Facilities	Manufacturer	Model # Serial #	Data Of Cal.
1	SIGNAL GENERATOR	ROHDE & SCHWARZ	SMY02 845181/025	MAR/2006
2	AMPLIFIER	AMPLIFIER RESEARCH	100W1000M1A	N/A
3	FIELD SENSOR	AMPLIFIER RESEARCH	FP2000	AUG/2004
4	FIELD MONITOR	AMPLIFIER RESEARCH	FM2000	AUG/2004
5	RF VOLTMETER	BOONTON	9200C 361701AA	MAR/2006
6	RF PROBE	BOONTON	952001B 37082	MAR/2006
7	DIRECTION COUPLER	AMPLIFIER RESEARCH	DC6180 20521	N/A
8	ANTENNA	EMCO	3142B S/N: 1789	N/A
9	CONTROL PC	KB TECH	KB P586/133	--

Note : Items 3 ~ 4 were calibrated with two years and verified before testing.

### 2 TEST PROCEDURE

According to **IEC 61000-4-3 (2002)**

According to **EN 55024 (1998) + A1 (2001) + A2 (2003)**

### 3 TEST SETUP

#### FERRITE TILE

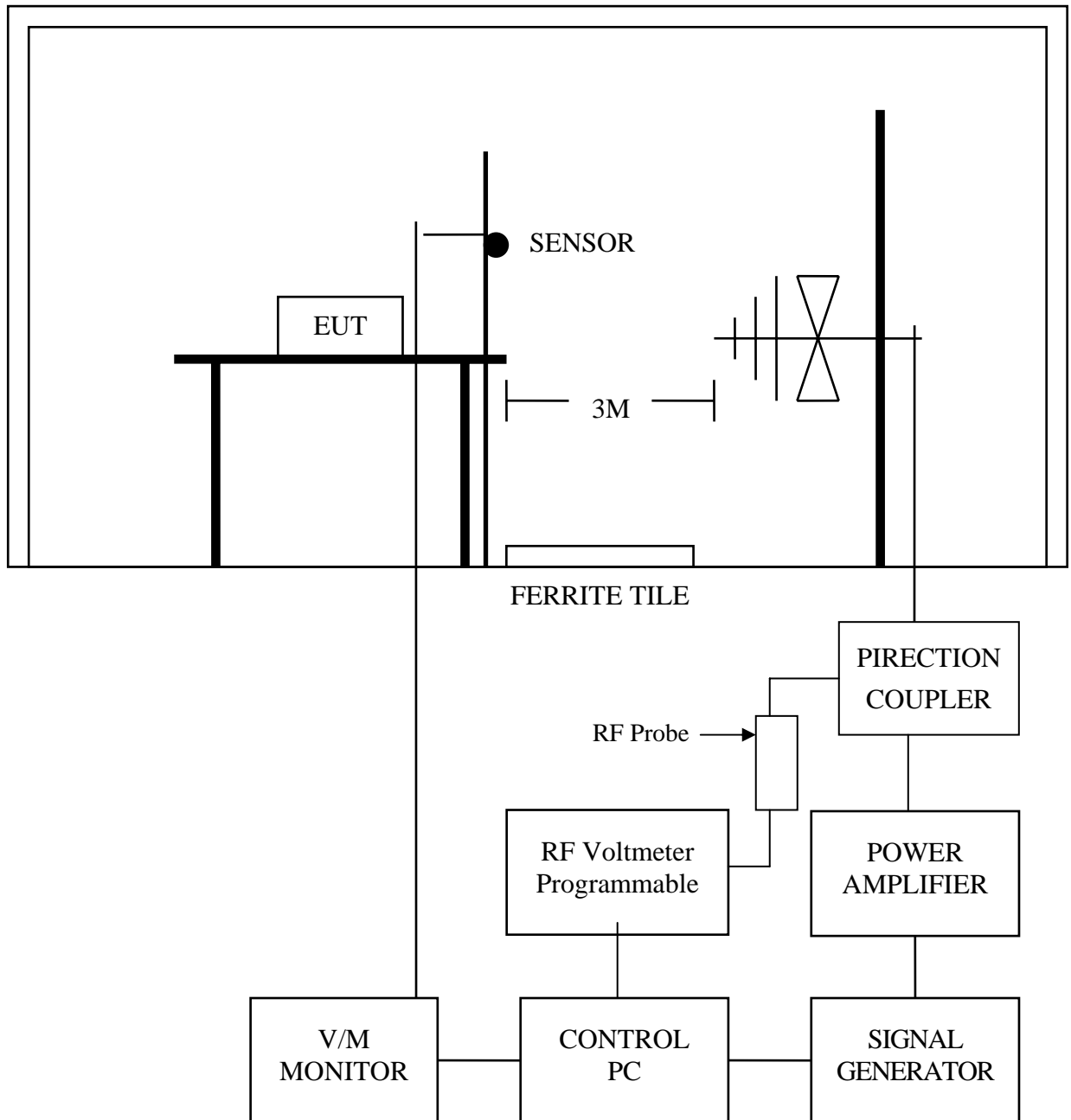

#### 3.1 Chamber Size :

12M x 5M x 5M

(Details for setup configuration, please refer to appendix A.)

#### 4 CONFIGURATION OF THE EUT

Same as “Conducted Power Line test”, section 4

#### 5 OPERATION CONDITION OF EUT

Same as “Conducted Power Line test”, section 5

#### 6 TEST CONDITION

6.1 Frequency Range : 80 MHz ~ 1000 MHz

(Frequency Range : 1.4 GHz ~ 2.0 GHz is not applicable for EN55024:1998+A1:2001+A2:2003)

6.2 Filed Strength : 3 V / M (1KHz 80% Modulation)

6.3 Frequency Step : 1 %, 3 sec. / each step size

6.4 Antenna Polarity : HORIZONTAL & VERTICAL

6.5 The four sides of EUT are tested  
(FRONT, REAR, RIGHT, LEFT)

6.6 Temperature : 25 °C

6.7 Humidity : 60 % RH

#### 7 PERFORMANCE CRITERIA

- A. The apparatus shall continue to operate as intended during and after the test. No degradation of performance or loss of function is allowed below a performance level specified by the manufacturer, when the apparatus is used as intended.
- B. The apparatus shall continue to operate as intended after the test. No degradation of performance or loss of function is allowed below a performance level specified by the manufacturer, when the apparatus is used as intended. The performance level may be replaced by a permissible loss of performance. During the test, degradation of performance is however allowed.
- C. Temporary loss of function is allowed, provided the function is self-recoverable or can be restored by the operation of the controls.

8 TEST RESULT

ANT SIDE	HORIZONTAL	VERTICAL	RESULT
FRONT	A	A	PASSED
REAR	A	A	PASSED
RIGHT	A	A	PASSED
LEFT	A	A	PASSED

9 Photos of test configuration please refer to appendix A.

## ELECTRICAL FAST TRANSIENT/BURST IMMUNITY TEST (EFT)

### 1 TEST INSTRUMENTS & FACILITIES

Instruments/ Facilities	Manufacturer	Model # Serial #	Data Of Cal.
BURST-TESTER	HAEFELY	PEFT/JUNIOR	FEB/2006
CONTROL PC	KB TECH	KB P586/133	--

### 2 TEST PROCEDURE

According to **IEC 61000-4-4 (2004)**

According to **EN 55024 (1998) + A1 (2001) + A2 (2003)**

### 3 TEST SETUP

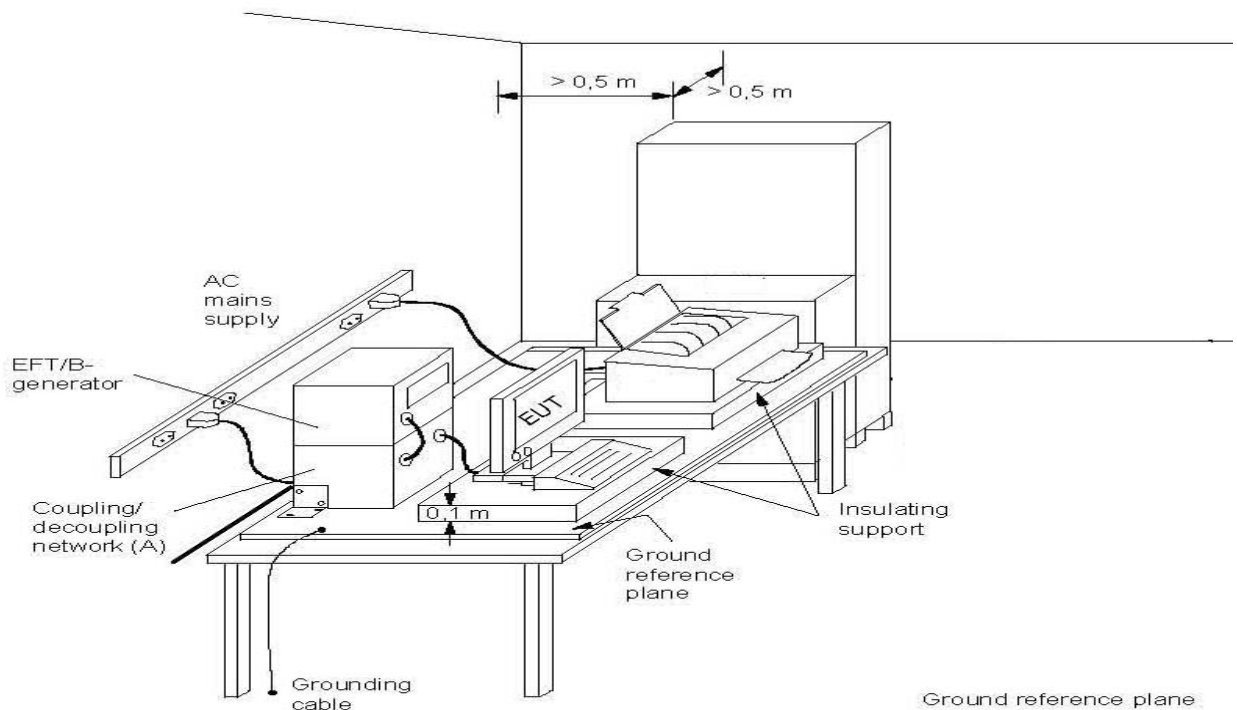

(Details for setup configuration, please refer to appendix A.)

Note: length between clamp and the EUT to be tested (should be  $0.5 \text{ m} \pm 0.05 \text{ m}$ )

(A) location for supply line coupling

(B) location for signal line coupling

#### 4 CONFIGURATION OF THE EUT

Same as “Conducted Power Line test”, section 4

#### 5 OPERATION CONDITION OF EUT

Same as “Conducted Power Line test”, section 5

#### 6 TEST CONDITION

6.1 Pulse Rise time & Duration : 5 nS / 50 nS

6.2 Pulse Repetition : 5 kHz

6.3 Polarity : POSITIVE / NEGATIVE

6.4 Test Voltage :  $\pm 0.5\text{KV}$ ,  $\pm 1\text{KV}$

6.5 Coupling of power line :  
L, N, PE, L+N, L+PE, N+PE, L+N+PE

6.6 Temperature : 25 °C

6.7 Humidity : 60 % RH

#### 7 PERFORMANCE CRITERIA

- A. The apparatus shall continue to operate as intended during and after the test. No degradation of performance or loss of function is allowed below a performance level specified by the manufacturer, when the apparatus is used as intended.
- B. The apparatus shall continue to operate as intended after the test. No degradation of performance or loss of function is allowed below a performance level specified by the manufacturer, when the apparatus is used as intended. The performance level may be replaced by a permissible loss of performance. During the test, degradation of performance is however allowed.
- C. Temporary loss of function is allowed, provided the function is self-recoverable or can be restored by the operation of the controls.

## 8 TEST RESULT

TEST VOLTAGE	L	N	PE	L+N	L+PE	N+PE	L+N+PE
±0.5KV	A	A	A	A	A	A	A
±1KV	A	A	A	A	A	A	A

8.1 Model : PR816

8.2 Test Mode : Full Load Mode

8.3 Final Result : PASSED

8.4 Remark :

## 9 Photos of test configuration please refer to appendix A.

## SURGE IMMUNITY TEST

### 1 TEST INSTRUMENTS & FACILITIES

Instruments/ Facilities	Manufacturer	Model # Serial #	Data Of Cal.
SURGER-TESTER	HAEFELY	PSURGE 4010 583334-38	FEB/2006
CONTROL PC	KB TECH	KB P586/133	--

### 2 TEST PROCEDURE

According To **IEC 61000-4-5 (2001)**

According To **EN 55024 (1998) + A1 (2001) + A2 (2003)**

### 3 TEST SETUP

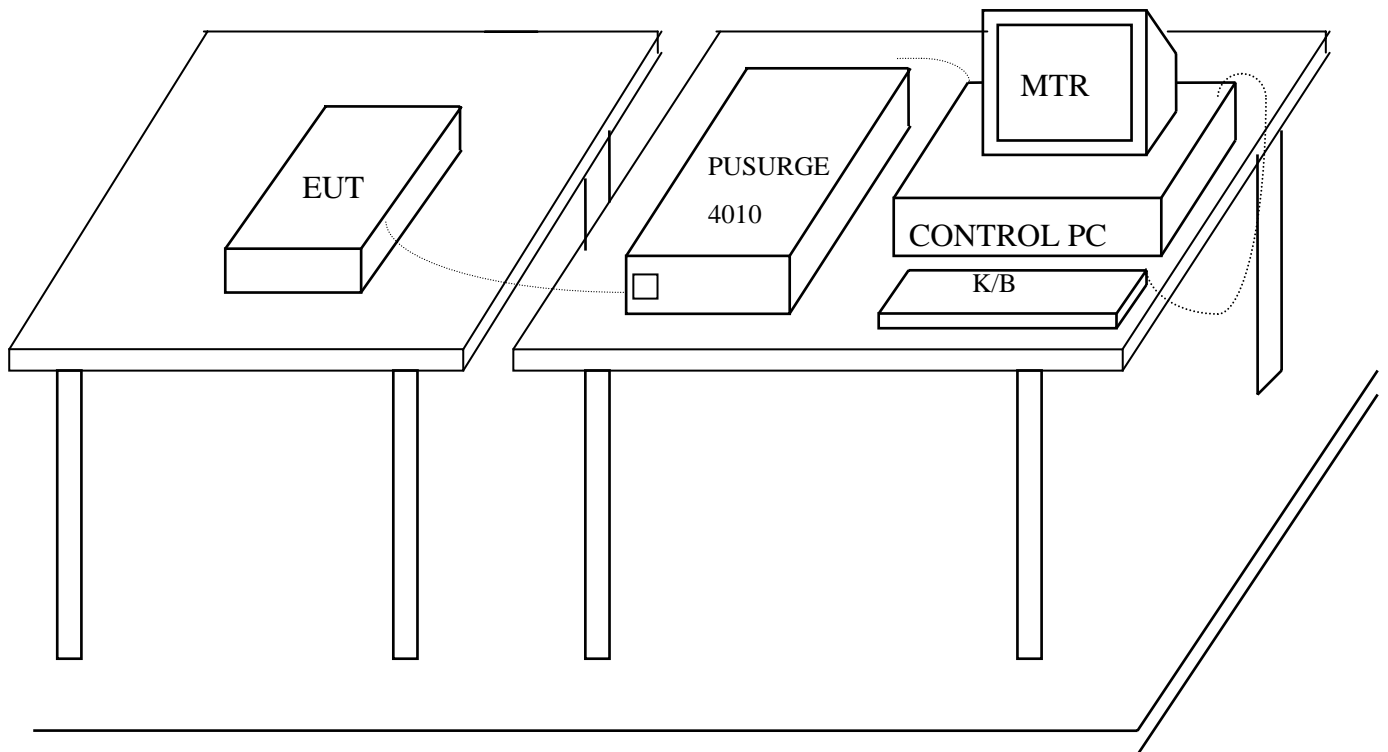

**GROUND PLANE**  
(Details for setup configuration, please refer to appendix A.)

#### 4 TEST LEVELS

- Input and Output AC Power Ports.
- DC Input and DC Output Power Ports.

Environmental Phenomena	Test Specification		Units	Performance Criteria
	AC	DC		
Surges	1.2 / 50 (8/20)		Tr /Th us	
Line to Line	±1	±0.5	KV (Charge Voltage)	B
Line to Earth	±2		KV (Charge Voltage)	B

#### 5 CONFIGURATION OF THE EUT

Same as “Conducted Power Line test”, section 4

#### 6 EUT OPERATION CONDITION

Same as “Conducted Power Line test”, section 5

#### 7 CONDITIONS DURING TESTING

7.1 Coupling of power line :

(A) Line to Line            ±1KV (AC) or ±0.5KV (DC)

(B) Line to Earth            ±2KV (AC)

7.2 Polarity : POSITIVE / NEGATIVE

7.3 Phase shifting in a range between 0° to 360°

7.4 Repletion rate at least 1 per min

7.5 Temperature :   25   °C (15°C ~ 35°C)

Humidity :   60   % RH.(10 % ~ 75%)

## 8 PERFORMANCE CRITERIA

- A. The apparatus shall continue to operate as intended during and after the test. No degradation of performance or loss of function is allowed below a performance level specified by the manufacturer, when the apparatus is used as intended.
- B. The apparatus shall continue to operate as intended after the test. No degradation of performance or loss of function is allowed below a performance level specified by the manufacturer, when the apparatus is used as intended. The performance level may be replaced by a permissible loss of performance. During the test, degradation of performance is however allowed.
- C. Temporary loss of function is allowed, provided the function is self-recoverable or can be restored by the operation of the controls.

## 9 TEST RESULT

Environmental Phenomena	Test Specification	Units	Performance
Line to Line	$\pm 1$	KV (Charge Voltage)	A
Line to Earth	$\pm 2$	KV (Charge Voltage)	A

9.1 Model : PR816

9.2 Test Mode : Full Load Mode

9.3 Final Result : PASSED

9.4 Remark :

## 10 Photos of test configuration please refer to appendix A.

## IMMUNITY TEST TO CS CONDUCTED DISTURBANCE

### 1 TEST INSTRUMENTS & FACILITIES

Instruments/ Facilities	Manufacturer	Model # Serial #	Date Of Cal.
SIGNAL GENERATOR	ROHDE & SCHWARZ	SMY02 845181/025	MAR/2006
AMPLIFIER	AMPLIFIER RESEARCH	75A250 25680	N/A
RF VOLTMETER	BOONTON	9200C 361701AA	MAR/2006
RF PROBE	BOONTON	952001B 37082	MAR/2006
DIRECTION COUPLER	AMPLIFIER RESEARCH	DC2600 20508	N/A
COUPLING DECOUPLING NETWORK	FCC	FCC-801-M3-25A 9993	MAR/2006
CONTROL PC	KB TECH	KB P586/133	--

### 2 TEST PROCEDURE

According To **IEC 61000-4-6 (2003) + A1 (2004)**

According To **EN 55024 (1998) + A1 (2001) + A2 (2003)**

### 3 TEST SETUP

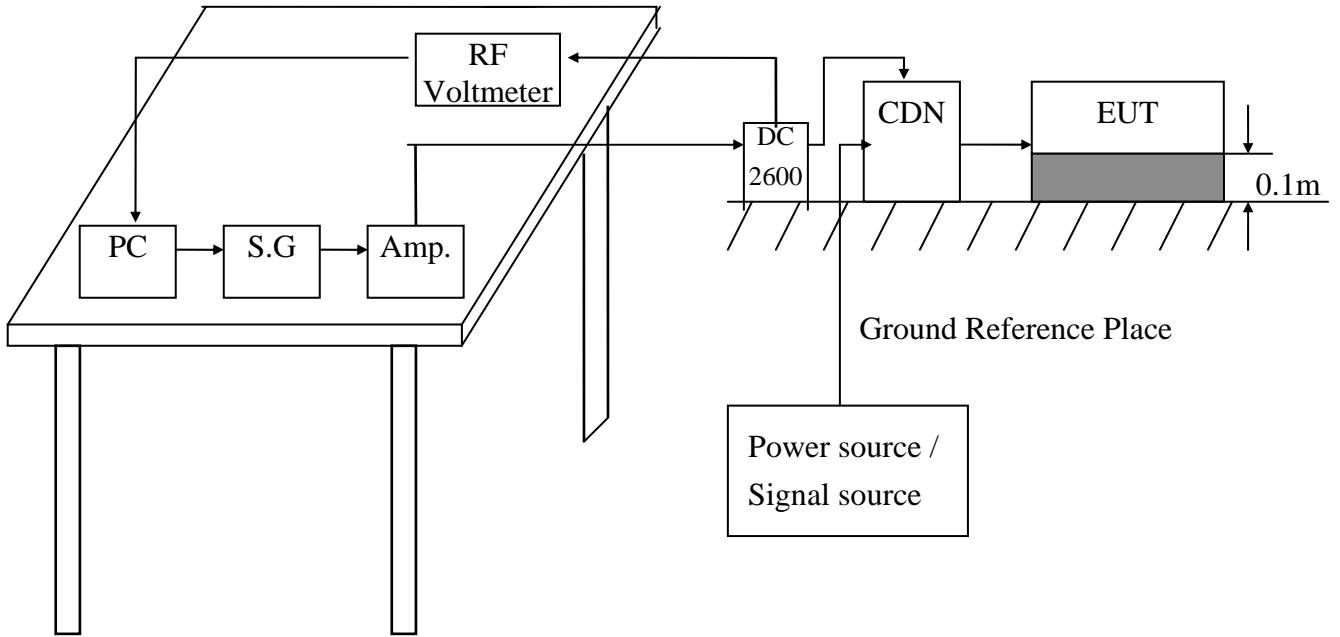

(Details for setup configuration, please refer to appendix A.)

#### 4 TEST LEVELS

- Ports for signal lines and control lines.
- DC input and DC output power ports.
- Input and Output AC Power Ports.
- Functional earth Ports.

Environmental	Test Specification	Units	Performance
Radio-frequency	0.15 - 80	MHz	
Common mode	3	V	A
	80	% AM (1KHz)	

#### 5 CONFIGURATION OF THE EUT

Same as “Conducted Power Line test”, section 4

#### 6 EUT OPERATION CONDITION

Same as “Conducted Power Line test”, section 5

#### 7 CONDITIONS DURING TESTING

7.1 The EUT tested type :

- Single unit
- Multiple unit

7.2 Dwell time : < 1%

7.3 Temperature : 25 °C (15°C ~ 35°C)

Humidity : 60 % RH.(10 % ~ 75%)

**8 PERFORMANCE CRITERIA**

- A. The apparatus shall continue to operate as intended during and after the test. No degradation of performance or loss of function is allowed below a performance level specified by the manufacturer, when the apparatus is used as intended.
- B. The apparatus shall continue to operate as intended after the test. No degradation of performance or loss of function is allowed below a performance level specified by the manufacturer, when the apparatus is used as intended. The performance level may be replaced by a permissible loss of performance. During the test, degradation of performance is however allowed.
- C. Temporary loss of function is allowed, provided the function is self-recoverable or can be restored by the operation of the controls.

**9 TEST RESULT**

TEST Specification	Unit	Performance Criteria
0.15 - 80	MHz	A
3	V	
80	% AM (1KHz)	

9.1 Model : PR816

9.2 Test Mode : Full Load Mode

9.3 Final Result : PASSED

9.4 Remark :

**10 Photos of test configuration please refer to appendix A.**

## POWER FREQUENCY MAGNETIC FIELD IMMUNITY TEST

### 1 TEST INSTRUMENTS & FACILITIES

Instruments/ Facilities	Manufacturer	Model # Serial #	Data Of Cal.
LINE INTERFERENCE TESTER	HAEFELY	PLINE 1610 080166-10	MAR/2006
MAGNETIC FIELD TESTER	HAEFELY	MAG 100.1 080206-01	N/A
TRIAXIAL ELF MAGNETIC FIELD METER	F.W.BELL	4080 9645	JUL/2005
CONTROL PC	KB TECH	KB P586/133	--

### 2 TEST STANDARD

According To **IEC 61000-4-8 (2001)**

According To **EN 55024 (1998) + A1 (2001) + A2 (2003)**

### 3 TEST SETUP

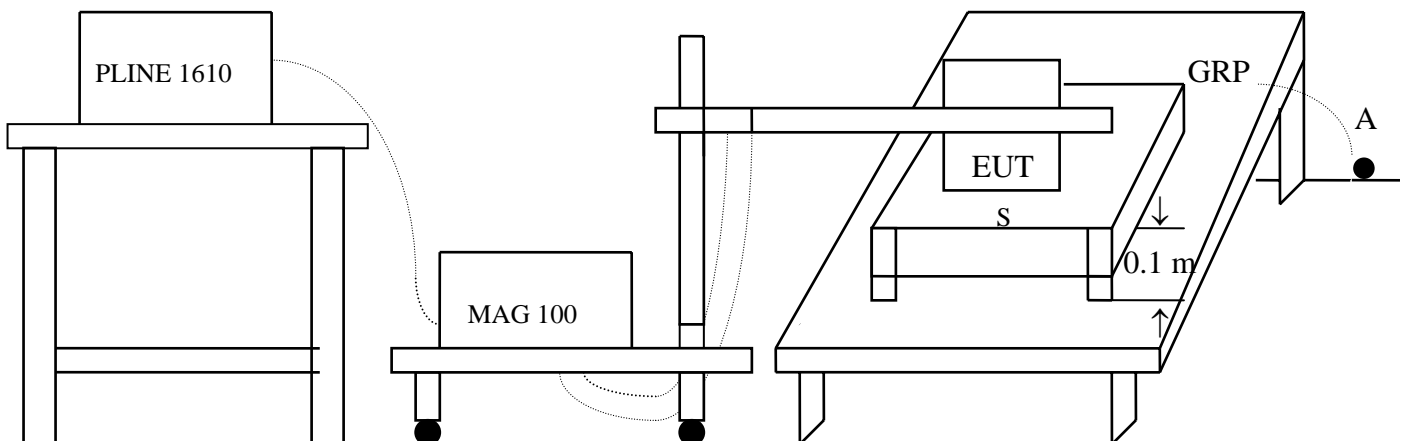

S: Insulating support

A: Safety earth

GRP: Ground plane

(Details for setup configuration, please refer to appendix A.)

#### 4 TEST LEVELS

Environmental Phenomena	Test Specification	Units	Performance Criteria
Power Frequency	50	HZ	
Magnetic Field	1	A/m	B

#### 5 CONFIGURATION OF THE EUT

Same as “Conducted Power Line test”, section 4

#### 6 OPERATION CONDITION OF EUT

Same as “Conducted Power Line test”, section 5

#### 7 CONDITIONS DURING TESTING

7.1 Temperature : 25 °C (15°C ~ 35°C)

Humidity : 60 % RH.(25 % ~ 75%)

7.2 The induction coil shall be rotated by 90°

#### 8 PERFORMANCE CRITERIA

- A. The apparatus shall continue to operate as intended during and after the test. No degradation of performance or loss of function is allowed below a performance level specified by the manufacturer, when the apparatus is used as intended.
- B. The apparatus shall continue to operate as intended after the test. No degradation of performance or loss of function is allowed below a performance level specified by the manufacturer, when the apparatus is used as intended. The performance level may be replaced by a permissible loss of performance. During the test, degradation of performance is however allowed.
- C. Temporary loss of function is allowed, provided the function is self-recoverable or can be restored by the operation of the controls.

## 9 TEST RESULTS

Environmental Phenomena	Test Specification	Units	Performance Criteria
Magnetic Field	1	A/m	A

9.1 Model : PR816

9.2 Test Mode : Full Load Mode

9.3 Final Results : PASSED

9.4 Remark :

**10 Photos of test configuration please refer to appendix A.**

## VOLTAGE DIPS, SHORT INTERRUPTIONS IMMUNITY TEST

### 1 TEST INSTRUMENTS & FACILITIES

Instruments/ Facilities	Manufacturer	Model # Serial #	Data Of Cal.
LINE INTERFERENCE -TESTER	HAEFELY	PLINE 1610 080166-10	MAR/2006
CONTROL PC	KB TECH	KB P586/133	--

### 2 TEST PROCEDURE

According To **IEC 61000-4-11 (2004)**

According To **EN 55024 (1998) + A1 (2001) + A2 (2003)**

### 3 TEST SETUP

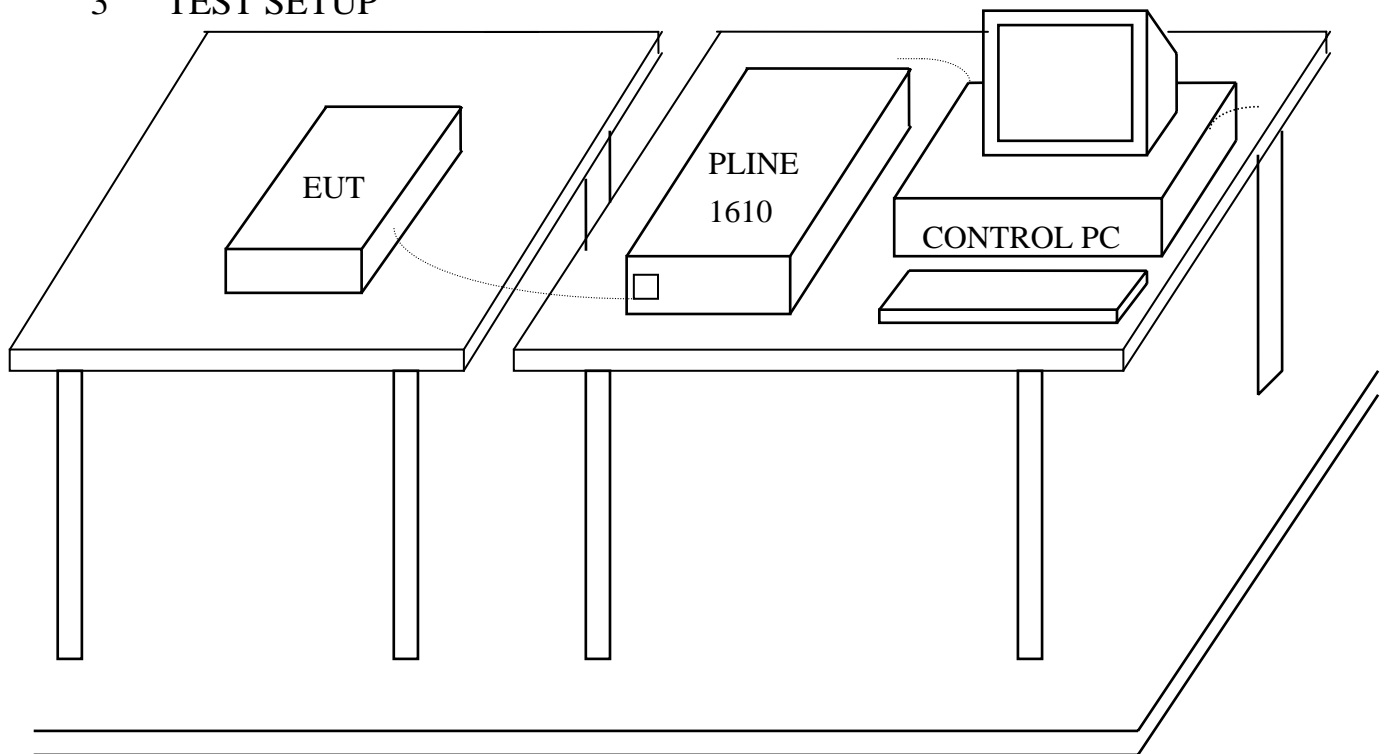

**GROUND PLANE**

(Details for setup configuration, please refer to appendix A.)

#### 4 TEST LEVELS

Input and Output AC Power Ports.

- Voltage Dips.
- Voltage Interruptions.

Class <sup>a</sup>	Test level and durations for voltage dips				
Class 1	Case-by-case according to the equipment requirements				
Class 2	0 % during 1/2 cycle	0 % during 1 cycle	70 % during 25/30 <sup>c</sup> cycles		
Class 3	0 % during 1/2 cycle	0 % during 1 cycle	40 % during 10/12 <sup>c</sup> cycles	70 % during 25/30 <sup>c</sup> cycles	80 % during 250/300 <sup>c</sup> cycles
a: Classes as per IEC 61000-2-4. b: To be defined by product committee. For equipment connected directly or indirectly to the public network, the levels must not be less severe than Class 2. c: “25/30 cycles” means “25 cycles for 50 Hz test” and “30 cycles for 60 Hz tet”.					

Class <sup>a</sup>	Test level and durations for short interruptions (t <sub>s</sub> ) (50Hz / 60Hz)
Class 1	Case-by-case according to the equipment requirements
Class 2	0 % during 250/300 <sup>c</sup> cycles
Class 3	0 % during 250/300 <sup>c</sup> cycles
Class X <sup>b</sup>	X
a: Classes as per IEC 61000-2-4. b: To be defined by product committee. For equipment connected directly or indirectly to the public network, the levels must not be less severe than Class 2. c: “250/300 cycles” means “250 cycles for 50 Hz test” and “300 cycles for 60 Hz test”.	

✘ **According to the specification of EUT, Class 2 is applied.**

#### 5 CONFIGURATION OF THE EUT

Same as “Conducted Power Line test”, section 4

#### 6 EUT OPERATION CONDITION

Same as “Conducted Power Line test”, section 5

#### 7 CONDITIONS DURING TESTING

7.1 Temperature : 25 °C (15°C ~ 35°C)

Humidity : 60 % RH.(25 % ~ 75%)

## 8 PERFORMANCE CRITERIA

- A. The apparatus shall continue to operate as intended during and after the test. No degradation of performance or loss of function is allowed below a performance level specified by the manufacturer, when the apparatus is used as intended.
- B. The apparatus shall continue to operate as intended after the test. No degradation of performance or loss of function is allowed below a performance level specified by the manufacturer, when the apparatus is used as intended. The performance level may be replaced by a permissible loss of performance. During the test, degradation of performance is however allowed.
- C. Temporary loss of function is allowed, provided the function is self-recoverable or can be restored by the operation of the controls.

## 9 TEST RESULT

Environmental Phenomena	Test Specification	Units	Perform Criteria
Voltage Dips	0 1/2	% during Cycle	A
	0 1	% during Cycle	C
	70 25	% during Cycles	C
Voltage Short Interruptions	0 250	% during Cycles	C

9.1 Model : PR816

9.2 Test Mode : Full Load Mode

9.3 Final Results : PASSED

9.4 Remark :

## 10 Photos of test configuration please refer to appendix A.



HomeTek Technology Inc.

## **Appendix A**

# **PHOTOS OF TEST CONFIGURATION**

## PHOTO OF CONDUCTED POWER LINE TEST

Test Mode : Full Load , Model : PR816



Front View



Rear View

## PHOTO OF RADIATED EMISSION TEST

Test Mode : Full Load , Model : PR816

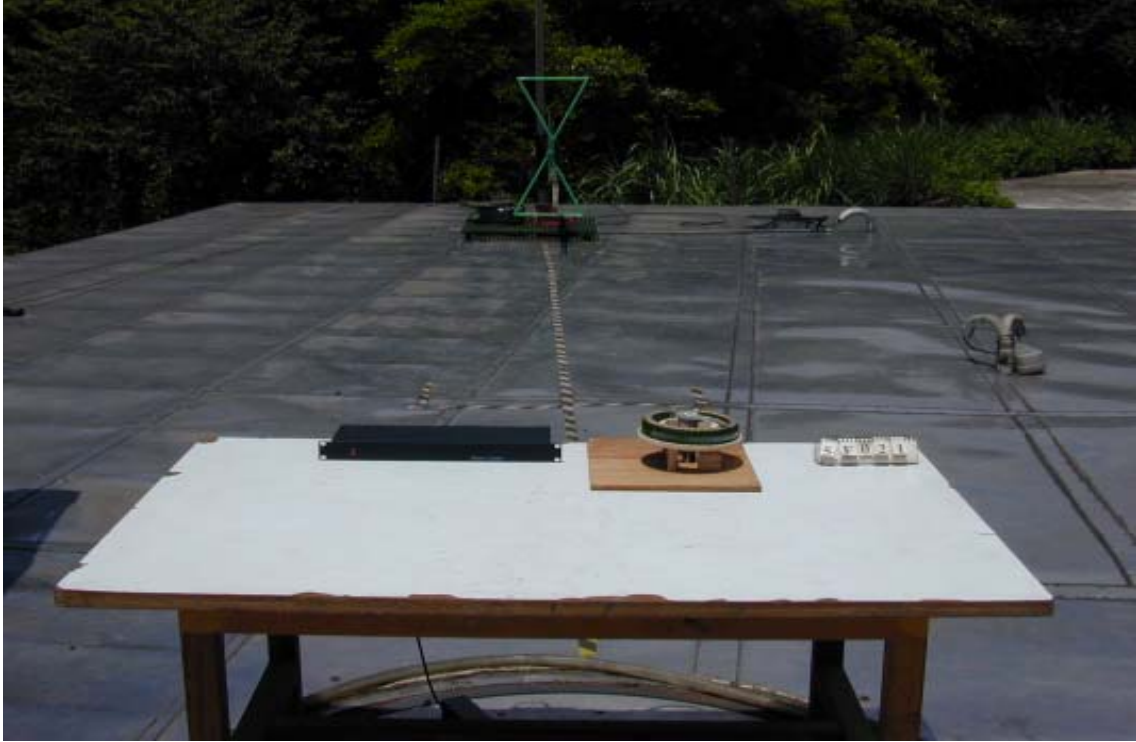

Front View



Rear View

### **PHOTO OF HARMONICS & VOLTAGE FLUCTUATIONS TEST AND SURGE IMMUNITY TEST AND VOLTAGE DIPS, SHORT INTERRUPTIONS IMMUNITY TEST**

Test Mode : Full Load , Model : PR816



### **PHOTO OF ELECTRICAL FAST TRANSIENT/BURST IMMUNITY TEST**



## PHOTO OF ELECTROSTATIC DISCHARGE IMMUNITY TEST (ESD)

Test Mode : Full Load , Model : PR816



## PHOTO OF POWER FREQUENCY MAGNETIC FIELD IMMUNITY TEST



## PHOTO OF RADIO FREQUENCY ELECTROMAGNETIC FIELD IMMUNITY TEST (RS)

Test Mode : Full Load , Model : PR816



## PHOTO OF CS CONDUCTED DISTURBANCE IMMUNITY TEST





HomeTek Technology Inc.

## **Appendix B**

### **PHOTOS OF EUT**

### PHOTO OF EUT

Model : PR816



Full View of EUT

# Declaration of Conformity

We(Manufacturer/Importer)

---

(company name)

---

(address)

declares under our sole responsibility that the product

Product name : Power Center

Model No. : PR8XXX

to which this declaration relates is in conformity with the following standard(s) or other normative document(s)

- |   |   |
|---|---|
| <input checked="" type="checkbox"/> EN 55022 Class B (1998) | <input checked="" type="checkbox"/> EN 55024 (1998)       |
| + A1 (2000)   | + A1 (2001)   |
| + A2 (2003)   | + A2 (2003)   |
| <input checked="" type="checkbox"/> EN 61000-3-2 (2000)     | <input checked="" type="checkbox"/> IEC 61000-4-2 (2001)  |
| <input checked="" type="checkbox"/> EN 61000-3-3 (1995)     | <input checked="" type="checkbox"/> IEC 61000-4-3 (2002)  |
| + A1 (2001)   | <input checked="" type="checkbox"/> IEC 61000-4-4 (2004)  |
|   | <input checked="" type="checkbox"/> IEC 61000-4-5 (2001)  |
|   | <input checked="" type="checkbox"/> IEC 61000-4-6 (2003)  |
|   | + A1 (2004)   |
|   | <input checked="" type="checkbox"/> IEC 61000-4-8 (2001)  |
|   | <input checked="" type="checkbox"/> IEC 61000-4-11 (2004) |

following the provisions of 89/336/EEC Directive

Place: \_\_\_\_\_ Signature: \_\_\_\_\_

Date : \_\_\_\_\_ Full name: \_\_\_\_\_



Title: \_\_\_\_\_



TÜV Rheinland Taiwan Ltd.

# Certificate

of

# Appointment

for the applicant:

**Hometek Technology Inc.**  
**No. 67-9, Shir Men Rd., Tu-Cheng City,**  
**Taipei Hsien 236, Taiwan, R.O.C.**

has been authorized to carry out EMC tests by order and under supervision of TÜV Rheinland. It has successfully demonstrated capability to conduct measurement and to process test data according to:

**European and International EMC Standards as listed in the  
Scope of Authorization on the attachment to this certificate**

An assessment of the facility was conducted by TÜV Rheinland auditors according to the TÜV Rheinland requirements for "Test Site Approval" with reference to

**ISO 17 025:1999**

**Certificate No. : 10012161-2006**

**Valid until : June 14, 2007**

TÜV Rheinland Taiwan Ltd.  
**Taipei, April 13, 2006**

  
Dipl.-Ing. Andreas Klinker  
Certification Body

  
Dipl.-Ing. Bodo Kretzschmar  
Product Safety and Quality



Attachment to  
**Certificate**  
of Appointment

SCOPE OF AUTHORIZATION

Hometek Technology Inc.  
No. 67-9, Shir Men Rd., Tu-Cheng City,  
Taipei Hsien 236, Taiwan, R.O.C.

**European Standards**

EN 50081-1	EN 61000-3-2	ENV 50140
EN 50081-2	EN 61000-3-3	ENV 50141
EN 50082-1	EN 61000-6-1	ENV 50204
EN 50130-4	EN 61000-6-2	
EN 50091-2	EN 61000-6-3	
EN 55011	EN 61000-6-4	
EN 55013	EN 61000-3-11	
EN 55014-1	EN 61000-4-2	
EN 55014-2	EN 61000-4-3	
EN 55022	EN 61000-4-4	
EN 55024	EN 61000-4-5	
EN 60601-1-2	EN 61000-4-6	
EN 60801	EN 61000-4-8	
EN 60945	EN 61000-4-11	
	EN 61204-3	

**International Standards**

CISPR 11	IEC 61000-4-2	IEC 61000-3-2
CISPR 13	IEC 61000-4-3	IEC 61000-3-3
CISPR 14-1	IEC 61000-4-4	IEC 61000-3-11
CISPR 14-2	IEC 61000-4-5	IEC 61000-6-1
CISPR 22	IEC 61000-4-6	IEC 61000-6-2
CISPR 24	IEC 61000-4-8	IEC 61000-6-3
	IEC 61000-4-11	IEC 61000-6-4
IEC 801.2	IEC 61000-4-12	IEC 60945
IEC 801.3		
IEC 801.4		

Certificate No. : 10012161-2006

Taipei, April 13, 2006

  
Dipl.-Ing. Bodo Kretzschmar  
Product Safety and Quality