



HomeTek Technology Inc.

ADDRESS: No. 67-9, Shir Men Road, Tu Cheng City,  
Taipei Hsien, Taiwan, R. O. C.

PHONE : 886-2-22608375 FAX : 886-2-22748013

E - mail : hometek@ms15.hinet.net

# CERTIFICATE OF COMPLIANCE

EUT : Power Supply

MODEL NO. : PW408X-XXX

Receipt Date : 01/12/2005 Final Test Date: 01/26/2005

REPORT # : EB4A024

APPLICANT : SMART CABLING & TRANSMISSION CORP.

ADDRESS : 7F-1, No. 168, Lien Cheng Rd.,  
Chung-Ho City, Taipei Hsien, Taiwan, R. O. C.

Measurement procedure used:

**EN 61204-3 (2000) Class B,**

**CISPR 22 Class B, EN 61000-3-2 (2000), EN 61000-3-3 (1995) + A1 (2001),**

**IEC 61000-4-2 (2001), IEC 61000-4-3 (2002), IEC 61000-4-4 (2004), IEC 61000-4-5 (2001),**

**IEC 61000-4-6 (2003) + A1 (2004), IEC 61000-4-11 (2004)**

We hereby show that:

The measurements shown in this test report were made in accordance with the procedures given in **EUROPEAN COUNCIL DIRECTIVE 89/336/EEC**, and the energy emitted by the equipment was found to be within the limits applicable.

This test result of this report applies to above tested sample only.

This test report shall not be reproduce in part without written approval of HomeTek Technology Inc.

PREPARED BY : Ming Yu Li DATE : 2/1/2005  
MING YU LI

CHECK BY : Albert Tsai DATE : 2/1/2005  
ALBERT TSAI / Senior Engineer

APPROVED BY : Tommy Rau DATE : 2/2/2005  
TOMMY RAU / Manager



**TABLE OF CONTENTS.....1**

**GENERAL INFORMATION.....4**

**MODIFICATION LIST.....6**

**CONDUCTED POWER LINE TEST.....7**

1 TEST INSTRUMENTS & FACILITIES .....7

2 TEST PROCEDURE.....7

3 TEST SETUP .....8

4 CONFIGURATION OF THE EUT..... 10

5 EUT OPERATING CONDITION..... 14

6 LIMIT OF CONDUCTED POWER LINE EMISSION CLASS B..... 14

7 RESULT OF CONDUCTED POWER LINE TEST ..... 14

8 CONDUCTED POWER LINE TEST DATA (PAGE 1) ..... 15

9 CONDUCTED POWER LINE TEST DATA (PAGE 2) ..... 16

10 CONDUCTED POWER LINE TEST DATA (PAGE 3) ..... 17

11 CONDUCTED POWER LINE TEST DATA (PAGE 4) ..... 18

**RADIATED EMISSION TEST ..... 19**

1 TEST INSTRUMENTS & FACILITIES ..... 19

2 TEST PROCEDURE..... 20

3 TEST SETUP ..... 20

4 CONFIGURATION OF THE EUT..... 21

5 EUT OPERATING CONDITION..... 21

6 LIMIT OF RADIATED EMISSION CLASS B..... 21

7 RESULT OF RADIATED EMISSION TEST ..... 21

8 RADIATED EMISSION TEST DATA (PAGE 1)..... 22

9 RADIATED EMISSION TEST DATA (PAGE 2)..... 23

**HARMONICS TEST..... 24**

1 TEST INSTRUMENTS & FACILITIES ..... 24

2 TEST PROCEDURE..... 24

3 TEST SETUP ..... 24

4 CONFIGURATION OF THE EUT..... 24

5 OPERATION CONDITION OF EUT ..... 24

6 TEST DATA & LIMIT..... 24

7 PHOTOS OF TEST CONFIGURATION PLEASE REFER TO APPENDIX A. .... 24

8 HARMONICS TEST DATA (PAGE 1~2)..... 25

**VOLTAGE FLUCTUATIONS TEST..... 27**

1 TEST INSTRUMENTS & FACILITIES ..... 27

2 TEST PROCEDURE..... 27

3 TEST SETUP ..... 27



4	CONFIGURATION OF THE EUT.....	27
5	OPERATION CONDITION OF EUT.....	27
6	TEST DATA & LIMIT.....	27
7	PHOTOS OF TEST CONFIGURATION PLEASE REFER TO APPENDIX A. ....	27
8	VOLTAGE FLUCTUATIONS TEST DATA (PAGE 1).....	28
<b>ELECTROSTATIC DISCHARGE IMMUNITY TEST (ESD) .....</b>		<b>29</b>
1	TEST INSTRUMENTS & FACILITIES .....	29
2	TEST PROCEDURE.....	29
3	TEST SETUP .....	29
4	CONFIGURATION OF THE EUT.....	30
5	EUT OPERATION CONDITION .....	30
6	TEST CONDITION.....	30
7	PERFORMANCE CRITERIA .....	30
8	TEST RESULT.....	31
<b>RADIO FREQUENCY ELECTROMAGNETIC FIELD IMMUNITY TEST (RF).....</b>		<b>32</b>
1	TEST INSTRUMENTS & FACILITIES .....	32
2	TEST PROCEDURE.....	32
3	TEST SETUP .....	33
4	TEST LEVELS.....	34
5	CONFIGURATION OF THE EUT.....	34
6	OPERATION CONDITION OF EUT.....	34
7	TEST CONDITION.....	34
8	PERFORMANCE CRITERIA .....	35
9	TEST RESULT.....	35
<b>ELECTRICAL FAST TRANSIENT/BURST IMMUNITY TEST (EFT) .....</b>		<b>36</b>
1	TEST INSTRUMENTS & FACILITIES .....	36
2	TEST PROCEDURE.....	36
3	TEST SETUP .....	36
4	CONFIGURATION OF THE EUT.....	37
5	OPERATION CONDITION OF EUT.....	37
6	TEST CONDITION.....	37
7	PERFORMANCE CRITERIA .....	37
8	TEST RESULT.....	38
<b>SURGE IMMUNITY TEST.....</b>		<b>39</b>
1	TEST INSTRUMENTS & FACILITIES .....	39
2	TEST PROCEDURE.....	39
3	TEST SETUP .....	39
4	TEST LEVELS.....	40
5	CONFIGURATION OF THE EUT.....	40



6	EUT OPERATION CONDITION .....	40
7	CONDITIONS DURING TESTING.....	40
8	PERFORMANCE CRITERIA .....	41
9	TEST RESULT .....	41
<b>IMMUNITY TEST TO CS CONDUCTED DISTURBANCE.....</b>		<b>42</b>
1	TEST INSTRUMENTS & FACILITIES .....	42
2	TEST PROCEDURE.....	42
3	TEST SETUP .....	43
4	TEST LEVELS.....	44
5	CONFIGURATION OF THE EUT.....	44
6	EUT OPERATION CONDITION .....	44
7	CONDITIONS DURING TESTING.....	44
8	PERFORMANCE CRITERIA .....	45
9	TEST RESULT .....	45
<b>VOLTAGE DIPS, SHORT INTERRUPTIONS IMMUNITY TEST.....</b>		<b>46</b>
1	TEST INSTRUMENTS & FACILITIES .....	46
2	TEST PROCEDURE.....	46
3	TEST SETUP .....	46
4	TEST LEVELS.....	47
5	CONFIGURATION OF THE EUT.....	47
6	EUT OPERATION CONDITION .....	47
7	CONDITIONS DURING TESTING.....	47
8	PERFORMANCE CRITERIA .....	48
9	TEST RESULT .....	48

**APPENDIX A**

PHOTOS OF TEST CONFIGURATION

**APPENDIX B**

PHOTOS OF EUT



### GENERAL INFORMATION

- 1 APPLICANT : SMART CABLING & TRANSMISSION CORP.
- 2 ADDRESS : 7F-1, No. 168, Lien Cheng Rd.,  
Chung-Ho City, Taipei Hsien, Taiwan, R. O. C.
- 3 MANUFACTURER : SMART CABLING & TRANSMISSION CORP.
- 4 ADDRESS : 7F-1, No. 168, Lien Cheng Rd.,  
Chung-Ho City, Taipei Hsien, Taiwan, R. O. C.
- 5 DESCRIPTION OF EUT :
  - EUT : Power Supply
  - Model : PW408X-XXX
  - Serial # : N/A

5.1 The difference between series of models PW408X-XXX is shown as below:

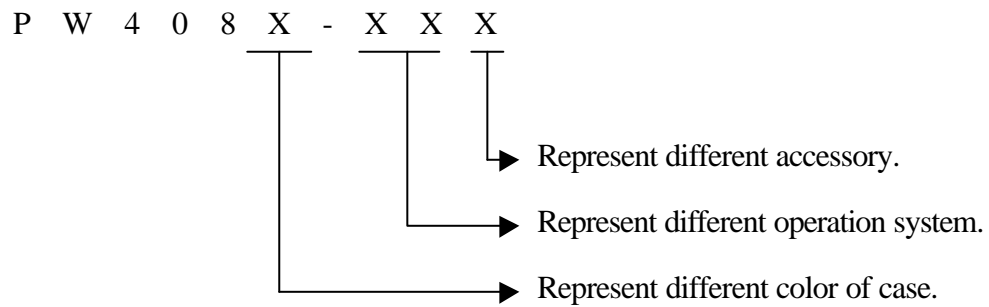

The worst case of EMC test model is PW408 and the final test data were shown in this test report.



## 6 FEATURES OF EUT :

**Please refer to user manual or product specification.**

## 7 TEST MODE :

The EUT were investigated with two DC voltage output modes shown as below:

- (1) Power output of DC 12V mode;
- (2) Power output of DC 24V mode

The worst case of EMC test mode is (2) Power output of DC 24V mode and the final test data were shown in this test report.



HomeTek Technology Inc.

## **MODIFICATION LIST**

THE FOLLOWING ACCESSORIES WERE ADDED TO THE EUT DURING TESTING :

NO MODIFICATION BY HOMETEK TECHNOLOGY INC.



## CONDUCTED POWER LINE TEST

### 1 TEST INSTRUMENTS & FACILITIES

The following test Instruments was used during the conducted test :

Item	Instruments/ Facilities	Specification	Manufacturer	Model #	Date Of Cal.
1	EMI Receiver	9KHz ~ 30MHz	ROHDE & SCHWARZ	ESHS 30 844827/007	MAR/2004
2	LISN (for EUT)	50 /50uH/100A 150KHz ~ 30MHz	SCHWARZ BECK	NNLK 8121 8121370	OCT/2004
3	LISN (for Support Unit)	50 /50uH/10A 9KHz ~ 30MHz	ROHDE & SCHWARZ	ESH3-Z5 846128/007	FEB/2004
4	Terminator	50	N/A	N/A	NOV/2004
5	Attenuation	50 /10dB	Mini-Circuit	NAT-10 AT-002	JUL/2004
6	Cable	5.4m	SUHNER	RG-223 CON2-002	AUG/2004
7	ESXS-K1 (software)	Version 2.03b 9KHz ~ 30MHz	ROHDE & SCHWARZ	1082.9678.02 840.913/246	N/A

Note : Items 1 ~ 6 were calibrated within period of 1 year.

### 2 TEST PROCEDURE

- 2.1 The EUT was tested according to **EN 61204-3**.
- 2.2 The EUT was placed 0.4 meter from the conducting wall of shielding room and kept at least 0.8 meter from any other grounded conducting surface.
- 2.3 The frequency range form 0.15 MHz to 30 MHz was investigated.
- 2.4 The LISN used was 50 Ohm / 50 uHenry as specified by **CISPR 22 Class B**.
- 2.5 All the support peripherals are connect to the other LISN.
- 2.6 Cables and peripherals were moved to find the maximum emission levels for each frequency.

### 3 TEST SETUP

#### 3.1 Typical : Setup Of Conducted Test

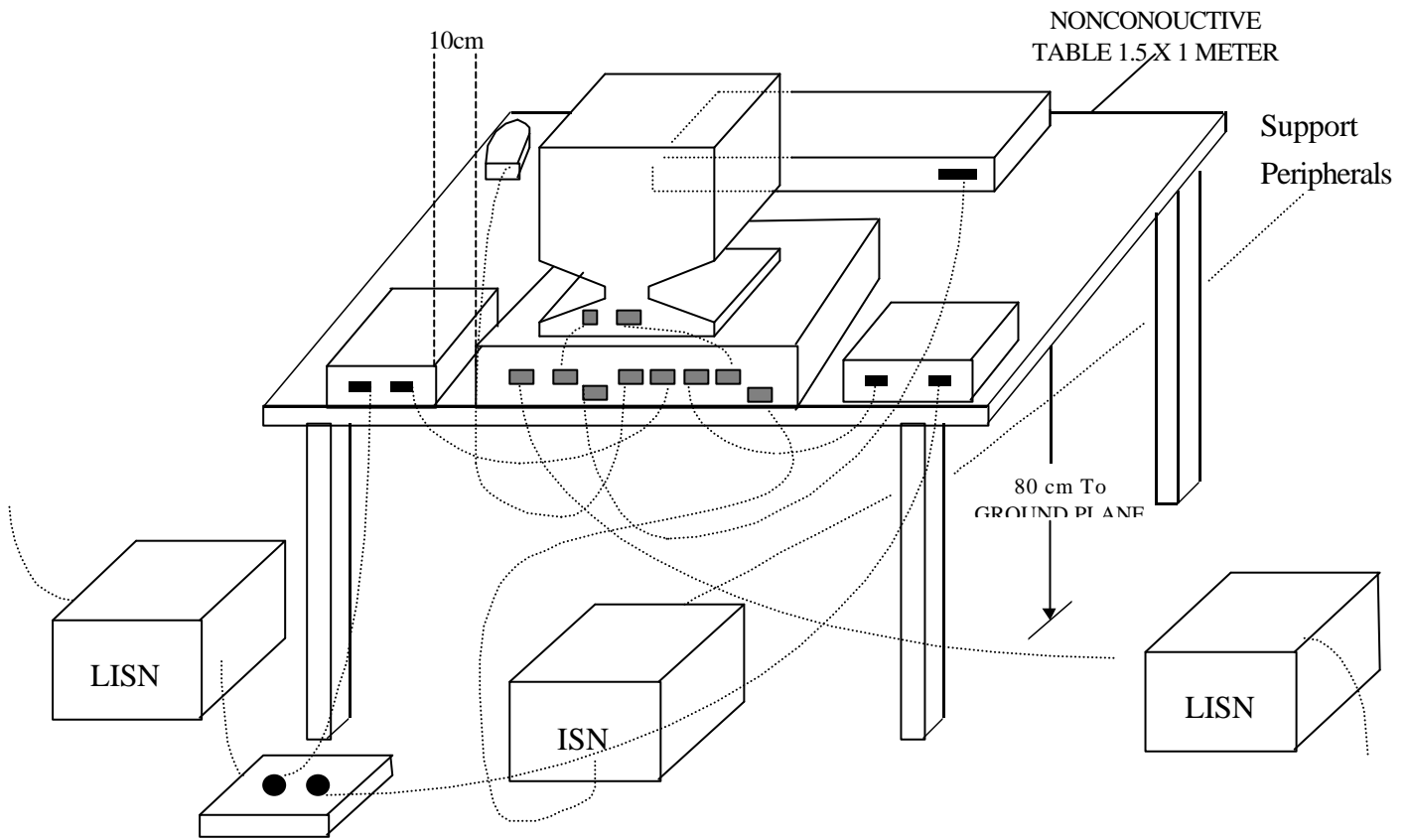

(Details for setup configuration, please refer to appendix A.)

### 3.2 Block Diagram Of Conducted Test

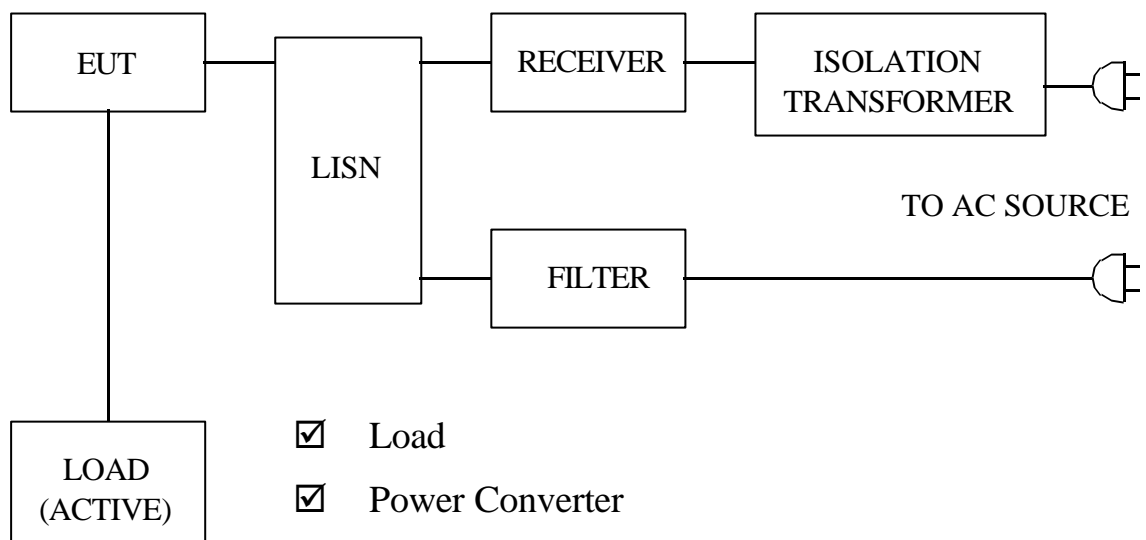

#### 4 CONFIGURATION OF THE EUT

The EUT was configured according to **EN 61204-3**. All I/O ports were connected to the appropriate peripherals. All peripherals and cables are listed below (including internal device) :

#### DC 24V Mode

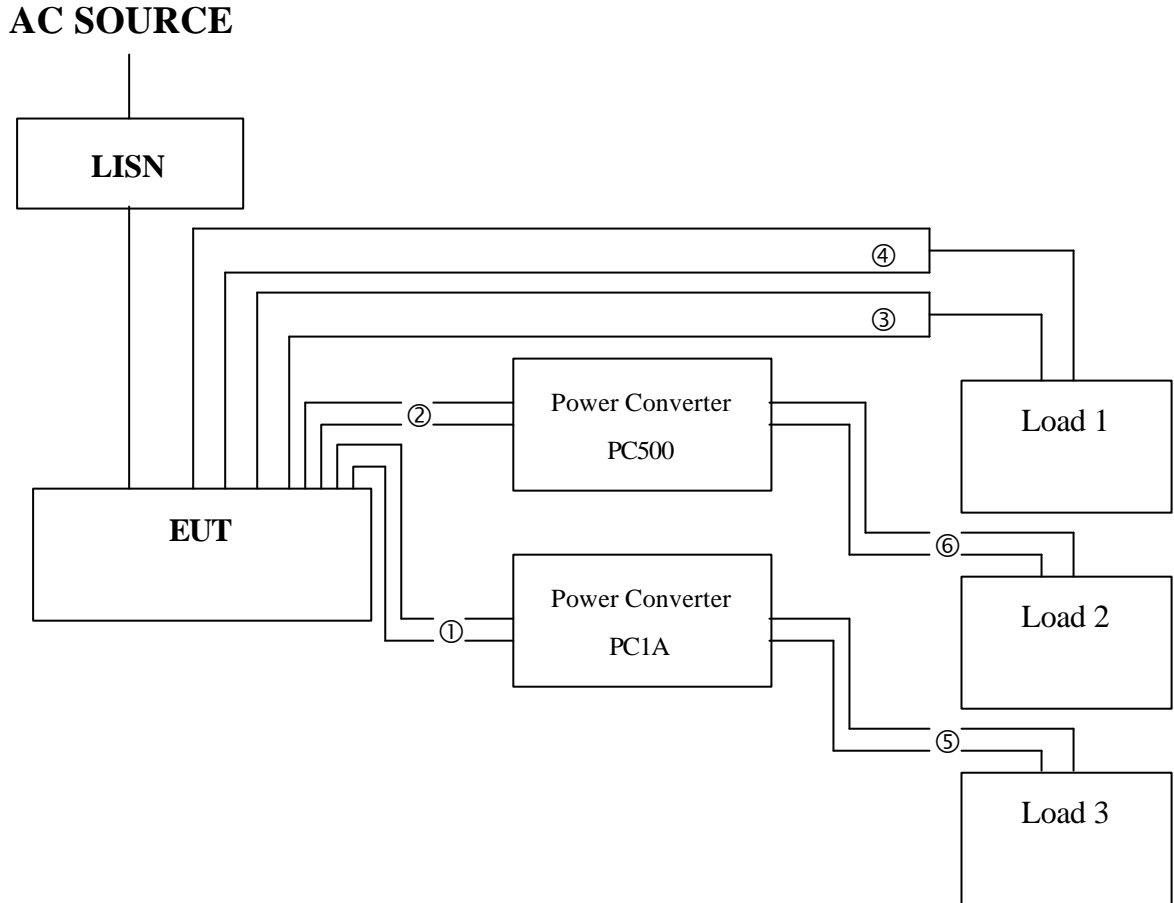

- ① DC,+ , - Power Cable Output (DC 24V)
- ② DC,+ , - Power Cable Output (DC 24V)
- ③ DC,+ Power Cable Output (DC 24V) x 6
- ④ DC,- Power Cable Output (DC 24V) x 6
- ⑤ DC,+ , - Power Cable Output (DC 12V, To Load)
- ⑥ DC,+ , - Power Cable Output (DC 12V, To Load)

Figure 1



#### 4.1 EUT

EUT Type : Proto Type Engineer Type Mass Production  
Condition when received : Good Damage : \_\_\_\_\_  
Device : Power Supply  
Applicant : SMART CABLING & TRANSMISSION CORP.  
Manufacturer : SMART CABLING & TRANSMISSION CORP.  
Model Number : PW408X-XXX  
Serial Number : N/A  
FCC ID : N/A  
Data Cable : N/A  
Power Cord (AC) : Un-Shielded, 1.8 m, 2 pin  
Power Cord (DC) : Un-Shielded, 1 m, 2 pin  
Power Supply Type : Linear

#### 4.2 PERIPHERALS

Power Converter  
Manufacturer : SMART CABLING & TRANSMISSION CORP.  
Model Number : PC1A  
Serial Number : N/A  
FCC ID : N/A  
Data Cable : N/A  
Power Cord : Un-Shielded, 1 m



Power Converter

Manufacturer : SMART CABLING & TRANSMISSION CORP.  
Model Number : PC500  
Serial Number : N/A  
FCC ID : N/A  
Data Cable : N/A  
Power Cord : Un-Shielded, 1 m

Load 1 (DC 24V Mode)

Manufacturer : HomeTek  
Specification : DC 24V / 9.6R / 60W  
Power Cord : Un-Shielded, 1 m

Load 2 from PC500 (DC 24V Mode)

Manufacturer : HomeTek  
Specification : DC 24V / 24R / 60W  
Power Cord : Un-Shielded, 1 m

Load 3 from PC1A (DC 24V Mode)

Manufacturer : HomeTek  
Specification : DC 24V / 12R / 60W  
Power Cord : Un-Shielded, 1 m



HomeTek Technology Inc.

Load 4 (DC 12V Mode)

Manufacturer : HomeTek

Specification : DC 12V / 3R / 120W

Power Cord : Un-Shielded, 1 m

4.3 REMARK : N/A



### 5 EUT OPERATING CONDITION

- 5.1 The frequency of the EUT is none.
- 5.2 Configure the EUT according to the **EN 61204-3**.
- 5.3 Connect AC 230V power to input port of EUT.
- 5.4 Power output of DC 12V mode:
  - EUT' s DC24V output port Connect to input port of Support Unit1(Power Converter PC1A) and input port of Support Unit2(Power Converter PC500) and dummy load(9.6R/60W Resistor)
  - DC12V output port of Support Unit1(Power Converter PC1A) connect to dummy load(12R/60W Resistor)
  - DC12V output port of Support Unit2(Power Converter PC500) connect to dummy load(24R/60W Resistor)
  - Monitor the status of output port of EUT during the test (For EMS Testing)
- 5.5 Power output of DC 24V mode:
  - EUT' s DC12V output port Connect to dummy load(3R/120W Resistor)
  - Monitor the status of output port of EUT during the test (For EMS Testing)
- 5.6 The photos of conducted test configuration, please refer to appendix A.**

### 6 LIMIT OF CONDUCTED POWER LINE EMISSION CLASS B

Frequency Range	Quasi Peak	Average
0.15 ~ 0.5 MHz	66 - 56 dBuV	56 - 46 dBuV
0.5 ~ 5 MHz	56 dBuV	46 dBuV
5 ~ 30 MHz	60 dBuV	50 dBuV

### 7 RESULT OF CONDUCTED POWER LINE TEST

- 7.1 The frequency range from 0.15 MHz to 30 MHz was investigated. All readings are quasi-peak values and average.
- 7.2 IF bandwidth : 9 kHz, Meas Time : 1 sec.
- 7.3 Temperature : 27 , Humidity : 60 % RH.
- 7.4 Deviations from the test standards and rules : None.
- 7.5 The conducted test result were gained by following procedures :  
 Level = Reading Level + Insertion Loss of LISN + Cable Loss  
 (All calculation were done by ESHS30 EMI test receiver.)
- 7.6 Result : **PASSED**



### 8 CONDUCTED POWER LINE TEST DATA (PAGE 1)

HomeTek EMC LAB. TEL :886-2-22608375

25 Jan 2005 13:43

#### CONDUCTED EMISSIONS

EUT: Power Supply (PW408)  
Manuf: 4A024  
Op Cond: LINE 1  
Operator: GENSIN  
Test Spec: FOR CISPR22 CLASS B  
Comment: 230V/50Hz  
DC 24V MODE  
Result File: 4a02411c.dat : 24V MODE

Prescan Measurement:      Detectors:      X PK / + AV  
                                 Meas Time:      see scan settings  
                                 Subranges:      16  
                                 Acc Margin:      55 dB

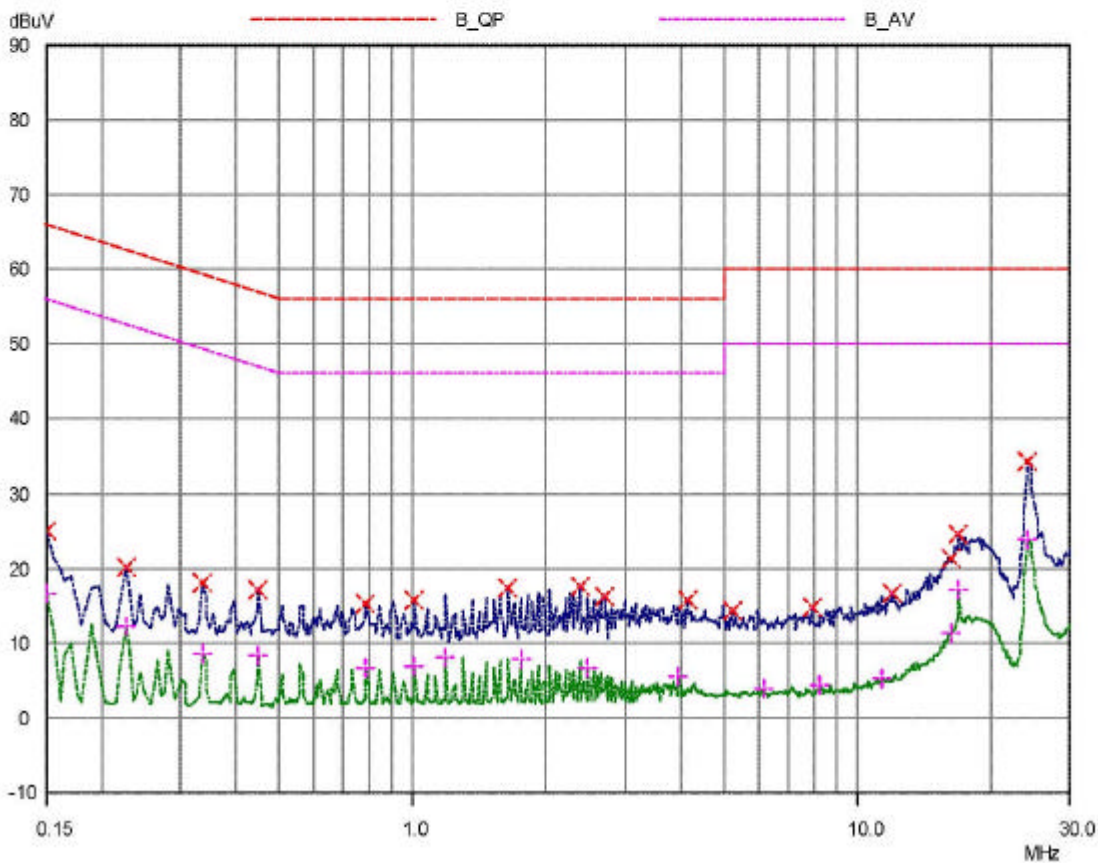



9 CONDUCTED POWER LINE TEST DATA (PAGE 2)

HomeTek EMC LAB. TEL :886-2-22608375

25 Jan 2005 13:43

CONDUCTED EMISSIONS

EUT: Power Supply (PW408)  
 Manuf: 4A024  
 Op Cond: LINE 1  
 Operator: GENSIN  
 Test Spec: FOR CISPR22 CLASS B  
 Comment: 230V/50Hz  
 DC 24V MODE  
 Result File: 4a02411c.dat : 24V MODE

Prescan Measurement: Detectors: X PK / + AV  
 Meas Time: see scan settings  
 Subranges: 16  
 Acc Margin: 55 dB

Peak Search Results

Frequency MHz	PK Level dBuV	PK Limit dBuV	PK Delta dB
0.15	25.10	66.00	40.90
0.225	20.12	62.63	42.51
0.335	18.02	59.33	41.31
0.45	17.03	56.88	39.85
0.785	15.21	56.00	40.79
1.01	15.75	56.00	40.25
1.63	17.29	56.00	38.71
2.36	17.52	56.00	38.48
2.7	16.33	56.00	39.67
4.09999	15.78	56.00	40.22
5.22	14.33	60.00	45.67
7.87	14.82	60.00	45.18
11.97	16.70	60.00	43.30
16.14998	21.30	60.00	38.70
16.76	24.50	60.00	35.50
24.07	34.27	60.00	25.73

Frequency MHz	AV Level dBuV	AV Limit dBuV	AV Delta dB
0.15	16.63	56.00	39.37
0.225	12.36	52.63	40.27
0.335	8.58	49.33	40.75
0.45	8.38	46.88	38.50
0.785	6.66	46.00	39.34
1.01	6.92	46.00	39.08
1.18	8.04	46.00	37.96
1.74	7.81	46.00	38.19
2.47	6.81	46.00	39.19
3.93	5.48	46.00	40.52
6.09	3.89	50.00	46.11
8.25	4.31	50.00	45.69
11.39	5.36	50.00	44.64
16.27	11.29	50.00	38.71
16.76	17.20	50.00	32.80
24.17	23.83	50.00	26.17

\*limit exceeded



### 10 CONDUCTED POWER LINE TEST DATA (PAGE 3)

HomeTek EMC LAB. TEL :886-2-22608375

25 Jan 2005 13:39

#### CONDUCTED EMISSIONS

EUT: Power Supply (PW408)  
Manuf: 4A024  
Op Cond: LINE 2  
Operator: GENSIN  
Test Spec: FOR CISPR22 CLASS B  
Comment: 230V/50Hz  
DC 24V MODE  
Result File: 4a02421c.dat : 24V MODE

Prescan Measurement:      Detectors:      X PK / + AV  
                                 Meas Time:      see scan settings  
                                 Subranges:      16  
                                 Acc Margin:      55 dB

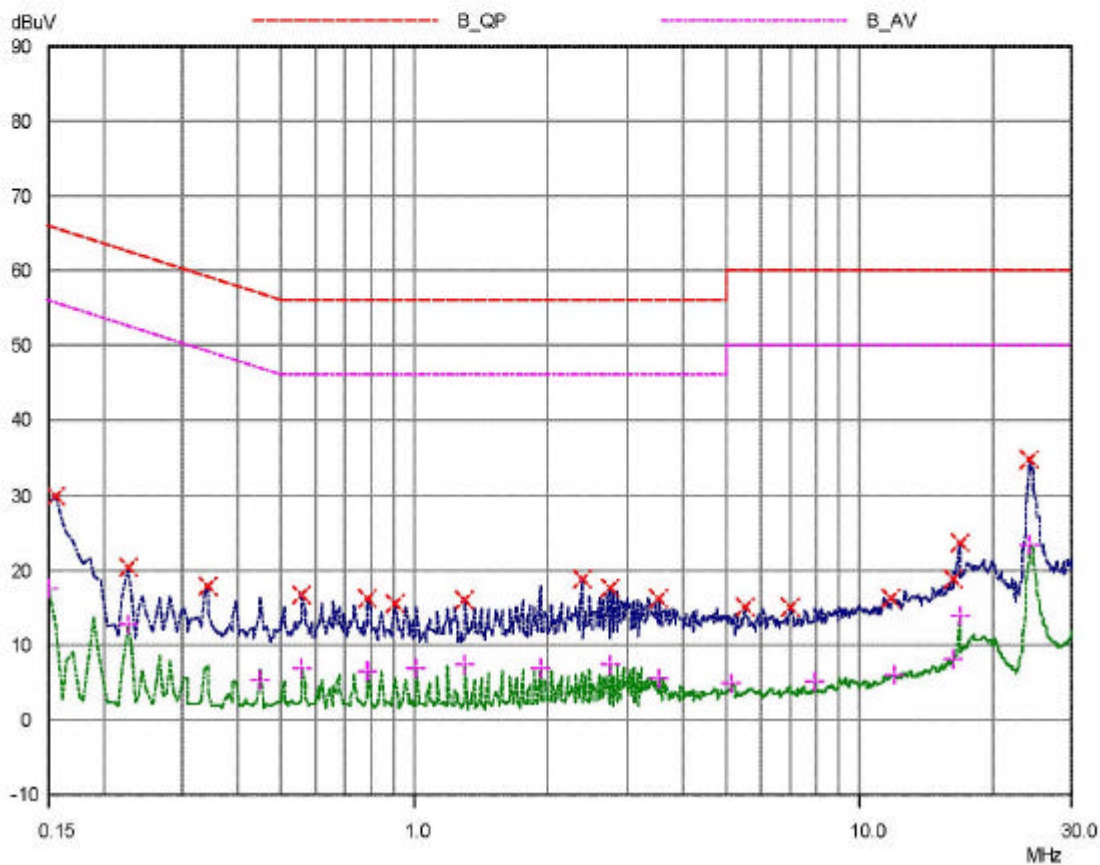



### 11 CONDUCTED POWER LINE TEST DATA (PAGE 4)

HomeTek EMC LAB. TEL :886-2-22608375

25 Jan 2005 13:39

#### CONDUCTED EMISSIONS

EUT: Power Supply (PW408)  
 Manuf: 4A024  
 Op Cond: LINE 2  
 Operator: GENSIN  
 Test Spec: FOR CISPR22 CLASS B  
 Comment: 230V/50Hz  
 DC 24V MODE  
 Result File: 4a02421c.dat : 24V MODE

Prescan Measurement:      Detectors:      X PK / + AV  
 Meas Time:                see scan settings  
 Subranges:                16  
 Acc Margin:                55 dB

#### Peak Search Results

Frequency MHz	PK Level dBuV	PK Limit dBuV	PK Delta dB
0.155	29.79	65.73	35.94
0.225	20.46	62.63	42.17
0.34	17.90	59.20	41.30
0.56	16.57	56.00	39.43
0.785	16.12	56.00	39.88
0.9	15.55	56.00	40.45
1.29	15.95	56.00	40.05
2.36	18.79	56.00	37.21
2.75	17.67	56.00	38.43
3.54	16.17	56.00	39.83
5.51	15.09	60.00	44.91
6.93	15.04	60.00	44.96
11.8	16.14	60.00	43.86
16.27	18.87	60.00	41.13
16.7	23.72	60.00	36.28
24.17	34.67	60.00	25.33

Frequency MHz	AV Level dBuV	AV Limit dBuV	AV Delta dB
0.15	17.57	56.00	38.43
0.225	12.78	52.63	39.85
0.445	5.35	46.97	41.62
0.56	6.88	46.00	39.12
0.785	6.44	46.00	39.56
1.01	6.91	46.00	39.09
1.29	7.44	46.00	38.56
1.91	6.88	46.00	39.12
2.75	7.42	46.00	38.58
3.54	5.53	46.00	40.47
5.16	4.78	50.00	45.22
7.91	5.10	50.00	44.90
11.89	5.97	50.00	44.03
16.19	8.12	50.00	41.88
16.7	13.90	50.00	36.10
24.16	23.35	50.00	26.65

\* limit exceeded



## RADIATED EMISSION TEST

### 1 TEST INSTRUMENTS & FACILITIES

The following test Instruments was used during the radiated emission test :

Item	Instruments /facilities	Specification	Manufacturer	Model # / S/N#	Date of Cal.
1	OPEN AREA TEST SITE	<input checked="" type="checkbox"/> OATS 3			JUL/2004
2	EMI TEST RECEIVER	30MHz ~ 1GHz	ROHDE & SCHWARZ	ESVS10 845165/017	SEP/2004
3	RF SPECTRUM ANALYZER	N/A	HEWLETT PACKARD	8591E 3710A06158	MAY/2004
4	PRE-AMPLIFIER	9KHz ~ 3000MHz	ADVANTEST	BB525C 90081001	SEP/2004
5	ANTENNA (BI-LOG)	25MHz ~ 2GHz	SCHAFFNER	CBL6112B S/N : 2614	MAY/2004
6	Attenuation	50 /6dB	JYE BAO	FAT-N (M-F) 001	JUL/2004
7	Cable	10m	SUHNER	RG214/U OS3-003	DEC/2004
8	Cable	14m	BELDEN	9913 OS3-001	DEC/2004
9	EMI 32 (software)	N/A	AUDIX	19991013-0923	N/A

Note : Items 1 ~ 8 were calibrated within period of 1 year.

## 2 TEST PROCEDURE

- 2.1 The EUT was test according to **CISPR 22 Class B**.
- 2.2 The radiated test was performed at HomeTek Lab' s Open Site III.
- 2.3 The frequency range from 30 MHz to 1 GHz, the measurement were made at 10 meters, with a BI-log antenna.

## 3 TEST SETUP

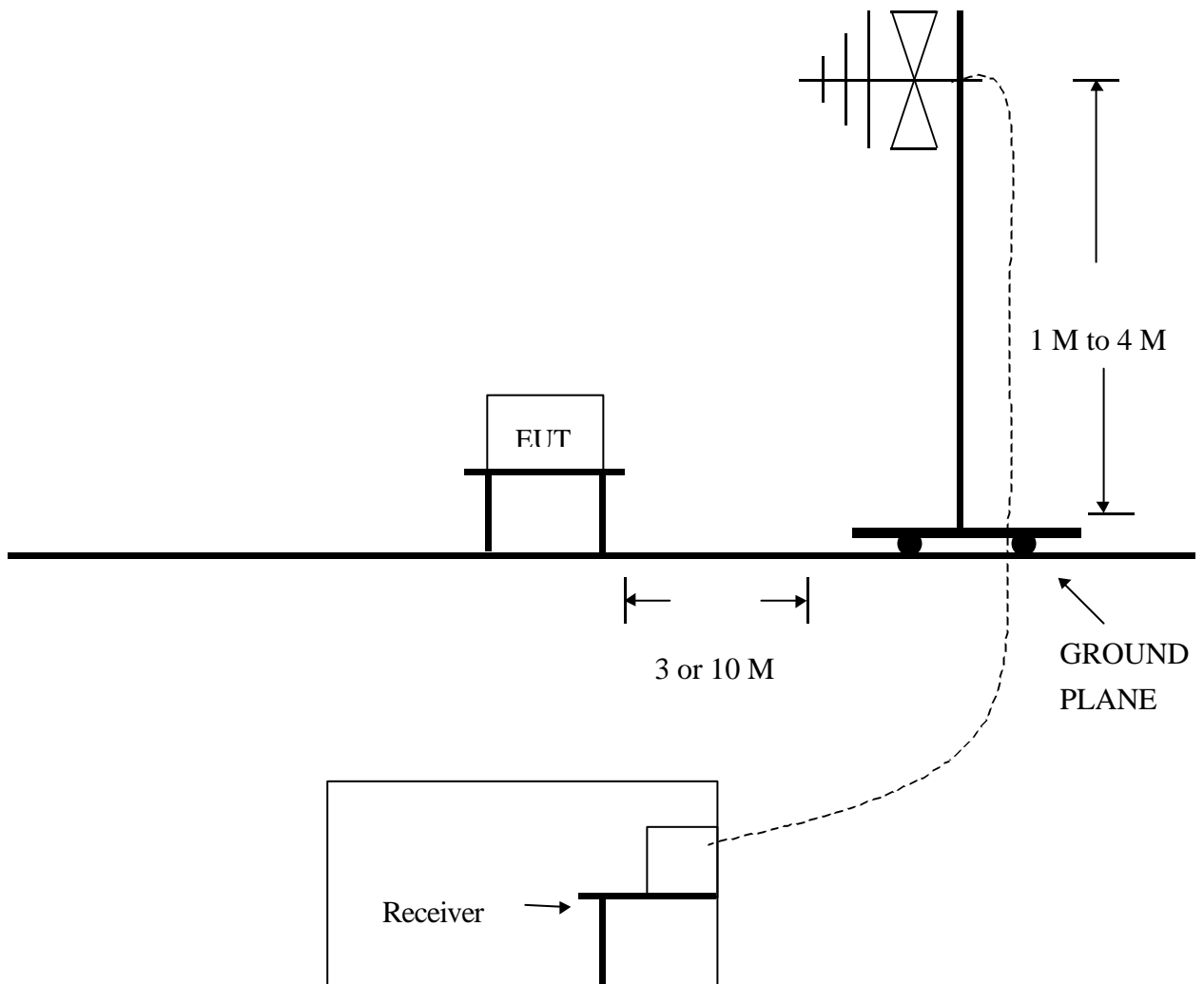

(Details for setup configuration, please refer to appendix A.)



4 CONFIGURATION OF THE EUT

Same as “Conducted Power Line test”, section 4

5 EUT OPERATING CONDITION

5.1 Same as “Conducted Power Line test”, section 5

5.2 The radiated emission in the frequency range from 30 MHz - 1000 MHz was test in a horizontal and vertical polarization at HomeTek Lab’ s open site III.

**5.3 The photos of radiated test configuration, please refer to appendix A.**

6 LIMIT OF RADIATED EMISSION CLASS B

Frequency (MHz)	Measurement Distance	Limit (dBuV/m)
30 - 230	10 (M)	30
230 - 1000	10 (M)	37

7 RESULT OF RADIATED EMISSION TEST

7.1 The frequency range from 30 MHz to 1 GHz was investigated.

7.2 All readings below or equal 1 GHz are quasi-peak or peak values with resolution bandwidth of 120 KHz.

7.3 The measurements were made at 10 meters of HomeTek Lab’ s open site III.

7.4 Temperature : 33 , Humidity : 55 % RH.

7.5 Deviation form the test standards and rules : None.

7.6 The radiated emission result were gained by the following method :

Level = Reading Level + Probe Factor (Antenna Factor) + Cable Loss – Preamp Factor

Over Limit = Level – Limit Line

7.7 Result : **PASSED**



HomeTek Technology Inc.

No 67-9, Shi-Men Rd., Tu-Chen City, Taipei County, Taiwan R.O.C. Tel:02-22608375 Fax:02-22748013

Data#: 3 File#: 4A024.emi

Date: 2005-01-18 Time: 16:23:23

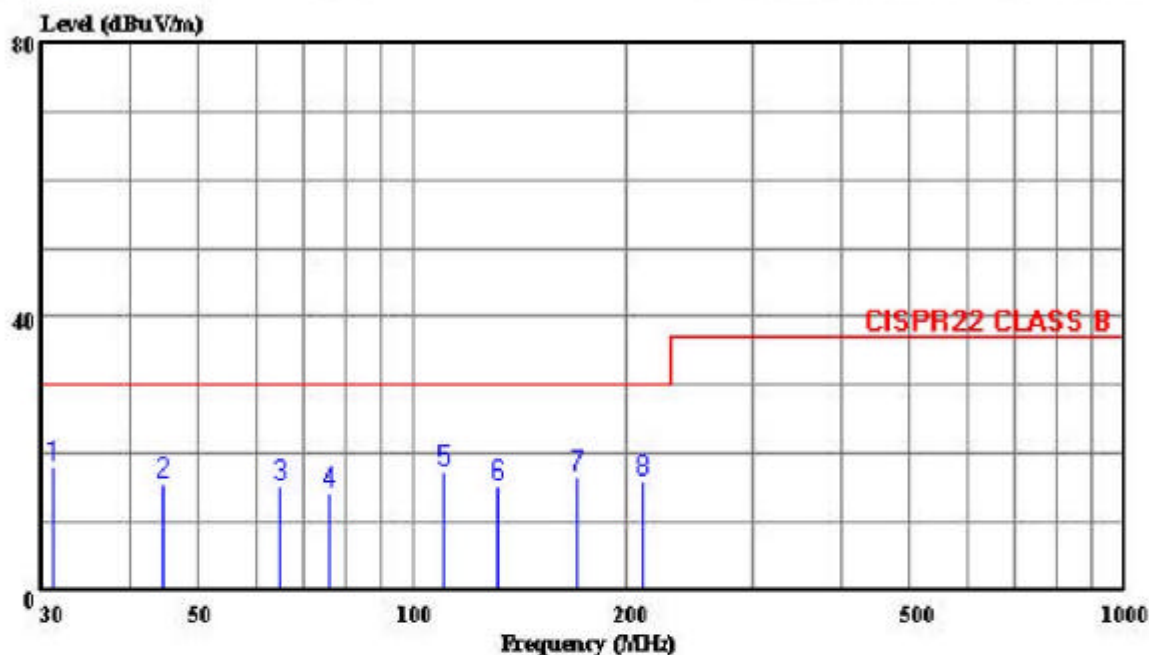

Trace:

Ref Trace:

Condition: CISPR22 CLASS B 10m CHASE 2614 052604 HORIZONTAL  
cut : Power Supply (PW409)  
power: 230V/50Hz  
memo : 24V MODE

Page: 1

	Freq	Level	Limit	Over	ReadAntenna	Cable	Preamp	Remark
	MHz	dBuV/m	Line	Limit	Level	Loss	Factor	
			dBuV/m	dB	dBuV	dB/m	dB	dB
1	31.247	18.06	30.00	-11.92	30.25	16.94	0.78	29.89 Peak
2	44.521	15.42	30.00	-14.58	33.61	10.80	0.90	29.89 Peak
3	65.135	15.18	30.00	-14.82	38.11	5.64	1.06	29.62 Peak
4	76.405	14.35	30.00	-15.65	36.16	6.48	1.14	29.43 Peak
5	110.517	17.43	30.00	-12.57	33.64	11.51	1.39	29.10 Peak
6	131.051	15.30	30.00	-14.70	31.71	11.32	1.49	29.22 Peak
7	170.034	16.58	30.00	-13.42	35.71	8.60	1.72	29.45 Peak
8	210.574	15.99	30.00	-14.01	35.15	8.50	1.96	29.61 Peak



HomeTek Technology Inc.

No 67-9, Shi-Men Rd., Tu-Chen City,  
 Taipei County, Taiwan R.O.C.  
 Tel: 02-22608375  
 Fax: 02-22748013

Data#: 4 File#: 4A024.emi

Date: 2005-01-19 Time: 16:47:15

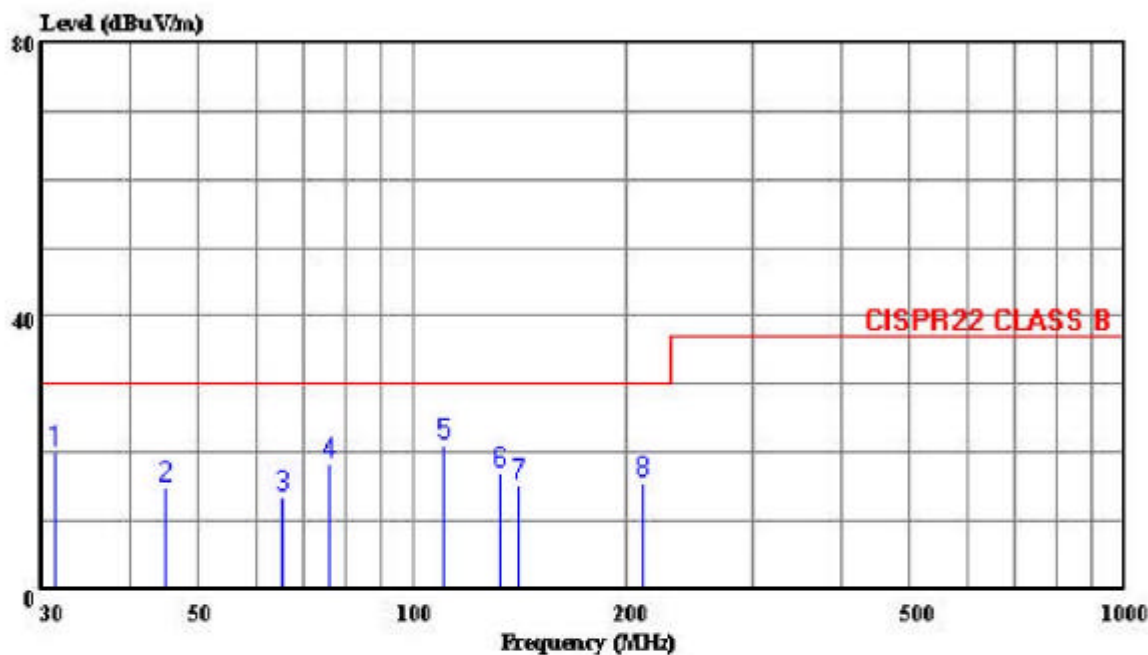

Trace:

Ref Trace:

Condition: CISPR22 CLASS B 10m CHASE 2614 052604 VERTICAL  
 out : Power Supply (PW408)  
 power: 230V/50Hz  
 memo : 24V MODE

Page: 1

	Freq	Level	Limit	Over	ReadAntenna	Cable	Preamp	Remark
	MHz	dBuV/m	dBuV/m	dB	Level	Loss	Factor	
					dB	dB	dB	
1	31.432	19.94	30.00	-10.06	32.14	16.91	0.78	29.89 Peak
2	44.715	14.93	30.00	-15.07	33.17	10.75	0.90	29.89 Peak
3	65.247	13.39	30.00	-16.61	36.31	5.63	1.06	29.62 Peak
4	76.030	18.27	30.00	-11.73	40.14	6.43	1.14	29.44 Peak
5	110.527	21.27	30.00	-8.73	37.49	11.51	1.39	29.10 Peak
6	132.448	17.10	30.00	-12.90	33.62	11.20	1.50	29.23 Peak
7	140.121	15.15	30.00	-14.85	32.37	10.50	1.55	29.28 Peak
8	210.440	15.67	30.00	-14.33	34.82	8.50	1.96	29.61 Peak

## HARMONICS TEST

### 1 TEST INSTRUMENTS & FACILITIES

Instruments/ facilities	Manufacturer	Model # Serial #	Date of Cal.
HARMONICS/ VOLTAGE FLUCTUATIONS TEST	EMC-PARTNER	HAR1000-1P	OCT/2004
CONTROL PC	KB TECH	KB P586/133	N/A

### 2 TEST PROCEDURE

According to **EN 61000-3-2 (2000) Class A**

### 3 TEST SETUP

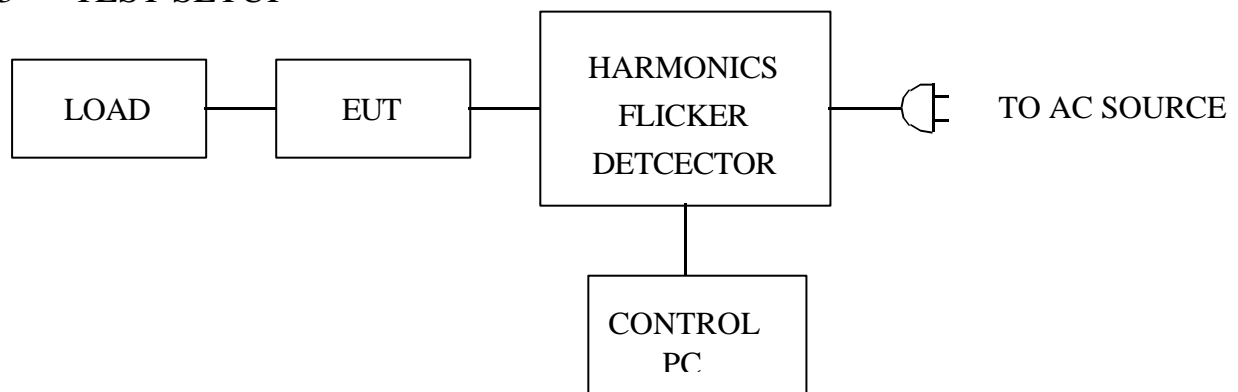

(Details for setup configuration, please refer to appendix A.)

### 4 CONFIGURATION OF THE EUT

Same as “Conducted Power Line test”, section 4

### 5 OPERATION CONDITION OF EUT

Same as “Conducted Power Line test”, section 5

### 6 TEST DATA & LIMIT

6.1 Temperature : 27

6.2 Humidity : 60 % RH

### 7 Photos of test configuration please refer to appendix A.



EMC PARTNER AG, SWITZERLAND

Date : 2005/1/17 02:36:07 P V2.05

File :

Operator : GENSIN  
 Unit : Power Supply  
 Serialnumber : PW408  
 Remarks : 4A024

Urms = 229.9V Freq = 49.984 Range: 2 A  
 Irms = 0.778A Ipk = 1.622A cf = 2.084  
 P = 146.1W Pap = 178.9VA pf = 0.816  
 THDi = 57.6 % THDu = 0.10 % Class A

Test - Time : 15min ( 100 %)

Test completed, Result: PASSED

Order	Freq. [Hz]	I <sub>max</sub> [A]	I <sub>max</sub> %L [%]	Limit [A]	Status
1	50	0.2572			
2	100	0.0088	0.8138	1.0800	
3	150	0.4260	11.633	2.3000	
4	200	0.0096	2.2424	0.4300	
5	250	0.1437	12.603	1.1400	
6	300	0.0087	2.8885	0.3000	
7	350	0.0363	4.7083	0.7700	
8	400	0.0056	2.4416	0.2300	
9	450	0.0537	13.427	0.4000	
10	500	0.0035	1.9244	0.1840	
11	550	0.0059	1.7758	0.3300	
12	600	0.0027	1.7516	0.1533	
13	650	0.0204	9.7093	0.2100	
14	700	0.0018	1.3928	0.1314	
15	750	0.0089	5.9398	0.1500	
16	800	0.0009	0.7431	0.1150	
17	850	0.0112	8.4871	0.1324	
18	900	0.0001	0.1195	0.1022	
19	950	0.0068	5.7732	0.1184	
20	1000	0.0001	0.1326	0.0920	
21	1050	0.0050	4.6697	0.1071	
22	1100	0.0001	0.1460	0.0836	
23	1150	0.0056	5.7428	0.0978	
24	1200	0.0001	0.1592	0.0767	
25	1250	0.0021	2.3066	0.0900	



HomeTek Technology Inc.

26	1300	0.0000	0.0000	0.0708
27	1350	0.0042	4.9780	0.0833
28	1400	0.0001	0.1859	0.0657
29	1450	0.0005	0.6289	0.0776
30	1500	0.0001	0.1992	0.0613
31	1550	0.0031	4.2017	0.0726
32	1600	0.0001	0.2123	0.0575
33	1650	0.0009	1.2522	0.0682
34	1700	0.0000	0.0000	0.0541
35	1750	0.0022	3.4156	0.0643
36	1800	0.0000	0.0000	0.0511
37	1850	0.0011	1.8072	0.0608
38	1900	0.0000	0.0000	0.0484
39	1950	0.0015	2.5370	0.0577
40	2000	0.0000	0.0000	0.0460

## VOLTAGE FLUCTUATIONS TEST

### 1 TEST INSTRUMENTS & FACILITIES

Instruments/ facilities	Manufacturer	Model # Serial #	Date of Cal.
HARMONICS/ VOLTAGE FLUCTUATIONS TEST	EMC-PARTNER	HAR1000-1P	OCT/2004
CONTROL PC	KB TECH	KB P586/133	N/A

### 2 TEST PROCEDURE

According to **EN 61000-3-3 (1995) + A1 (2001)**

### 3 TEST SETUP

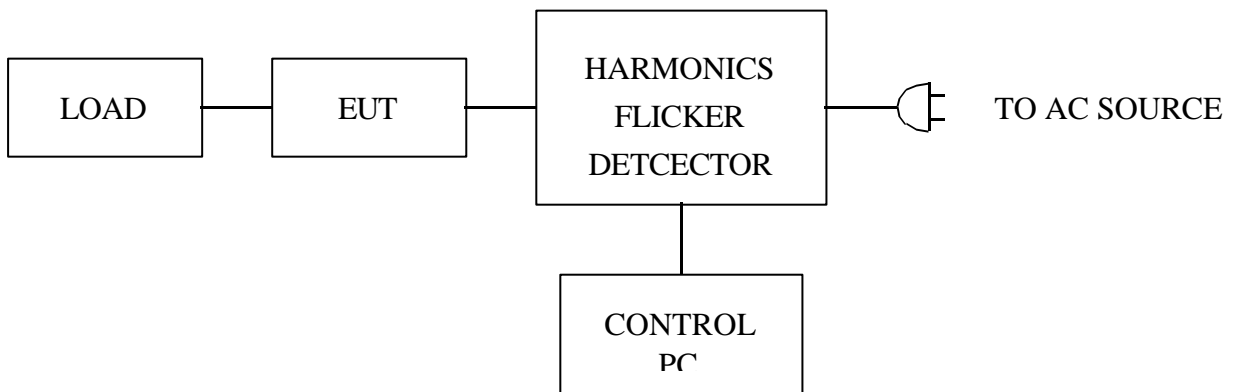

(Details for setup configuration, please refer to appendix A.)

### 4 CONFIGURATION OF THE EUT

Same as “Conducted Power Line test”, section 4

### 5 OPERATION CONDITION OF EUT

Same as “Conducted Power Line test”, section 5

### 6 TEST DATA & LIMIT

6.1 Temperature : 27

6.2 Humidity : 60 % RH

### 7 Photos of test configuration please refer to appendix A.



EMC PARTNER AG, SWITZERLAND

Date : 2005/1/17 02:13:45 P V2.05

File :

Operator : GENSIN  
 Unit : Power Supply  
 Serialnumber : PW408  
 Remarks : 4A024

Urms = 229.9V Freq = 49.984 Range: 5 A  
 Irms = 0.317A Ipk = 0.675A cf = 2.126  
 P = 59.20W Pap = 72.97VA pf = 0.811

Test - Time : 1 x 15min = 15min ( 100 %)

LIN (Line Impedance Network) : Soft LIN 0.24 Ohm +j 0.15 Ohm N: 0.16 Ohm +j 0.10 Ohm

Limits : Plt : 0.65 Pst : 1.00  
 dmax : 4.00 % dc : 3.00 %  
 dtLim: 3.00 % dt>Lim: 200ms

Test completed, Result: PASSED

Plt = 0.404

Pst dmax  
 [%]  
 1 0.404 0.250





#### 4 CONFIGURATION OF THE EUT

Same as “Conducted Power Line test”, section 4

#### 5 EUT OPERATION CONDITION

Same as “Conducted Power Line test”, section 5

#### 6 TEST CONDITION

6.1 Test Level :

(A)  $\pm 2, 4, 8$ KV for air discharge.

(B)  $\pm 2, 4$ KV for contact discharge.

6.2 Number of test : 10 Discharges / Test point / Polarity / Level

6.3 Time between test : 1 sec.

6.4 Temperature : 22

6.5 Humidity : 56 % RH.

#### 7 PERFORMANCE CRITERIA

A. Normal performance within the specification.

B. Temporary degradation or loss function or performance which is self-recoverable.

C. Temporary degradation or loss function or performance which requires operator intervention system reset.

D. Degradation or loss function which is not recoverable due to damage of EUT or software, or loss of data.

## 8 TEST RESULT

Test Point	Air Discharge	Contact Discharge	Performance Criteria	Result
HCP	---	$\pm 2, 4KV$	A	PASSED
VCP	---	$\pm 2, 4KV$	A	PASSED
CASE	$\pm 2, 4, 8KV$	$\pm 2, 4KV$	A	PASSED
I/O PORTS	$\pm 2, 4, 8KV$	$\pm 2, 4KV$	A	PASSED
SCREWS	$\pm 2, 4, 8KV$	$\pm 2, 4KV$	A	PASSED

## 9 Photos of test configuration please refer to appendix A.



## RADIO FREQUENCY ELECTROMAGNETIC FIELD IMMUNITY TEST (RS)

### 1 TEST INSTRUMENTS & FACILITIES

Item	Instruments Facilities	Manufacturer	Model # Serial #	Data Of Cal.
1	SIGNAL GENERATOR	ROHDE & SCHWARZ	SMY02 845181/025	MAR/2004
2	AMPLIFIER	AMPLIFIER RESEARCH	100W1000M1A	N/A
3	FIELD SENSOR	AMPLIFIER RESEARCH	FP2000	AUG/2004
4	FIELD MONITOR	AMPLIFIER RESEARCH	FM2000	AUG/2004
5	RF VOLTMETER	BOONTON	9200C 361701AA	MAR/2004
6	RF PROBE	BOONTON	952001B 37082	MAR/2004
7	DIRECTION COUPLER	AMPLIFIER RESEARCH	DC6180 20521	N/A
8	ANTENNA	EMCO	3142B S/N: 1789	N/A
9	CONTROL PC	KB TECH	KB P586/133	--

Note : Items 3 ~ 4 were calibrated with two years and verified before testing.

### 2 TEST PROCEDURE

According to **IEC 61000-4-3 (2002)**

According to **EN 61204-3 (2000)**

### 3 TEST SETUP

#### FERRITE TILE

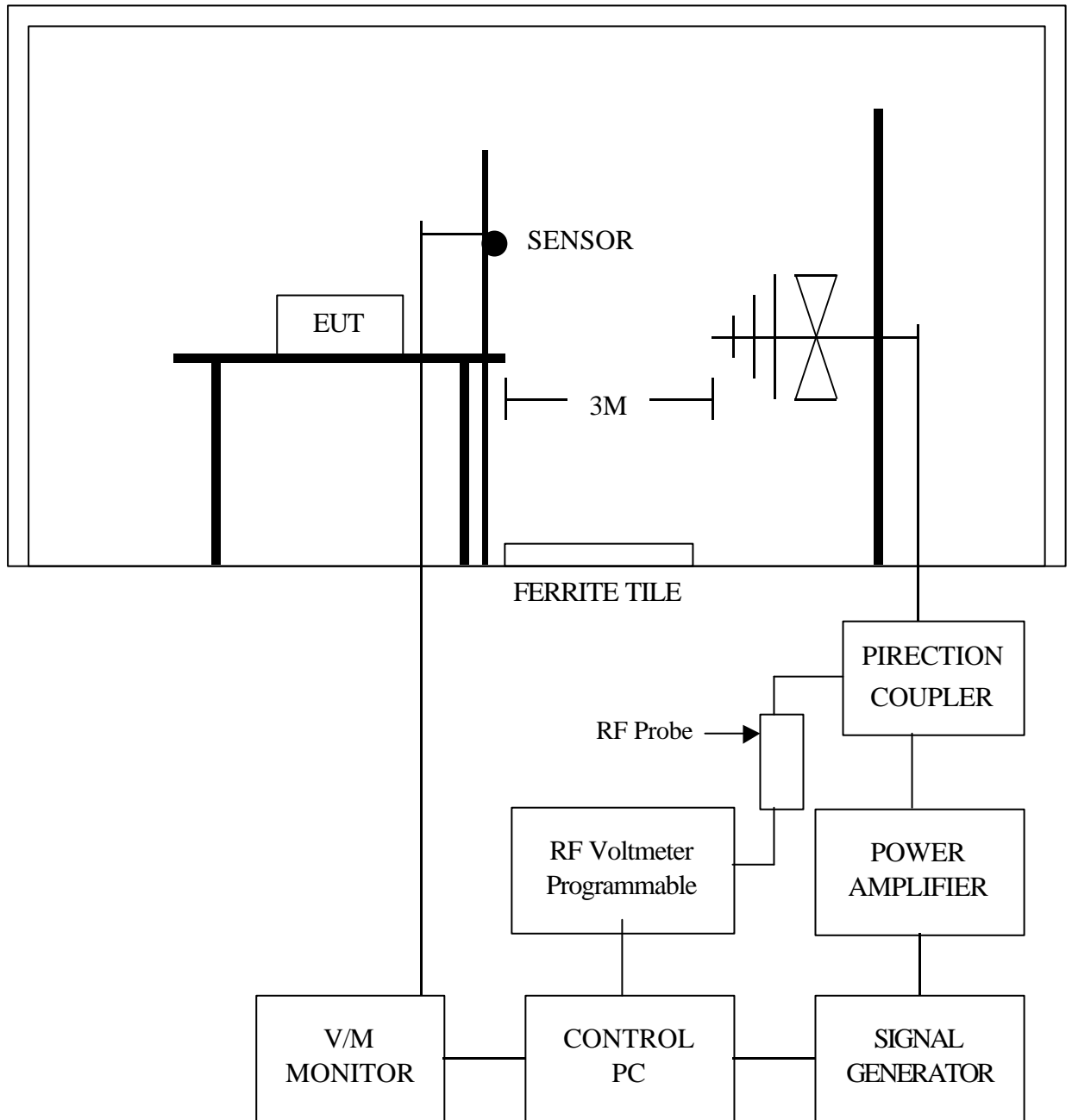

#### 3.1 Chamber Size :

12M x 5M x 5M

(Details for setup configuration, please refer to appendix A.)



#### 4 TEST LEVELS

Environmental Phenomenon	Test Item	Test Specification
Radio-frequency Electromagnetic Field Amplitude Modulated	Frequency Range	80MHz ~ 1000MHz (Frequency Range : <u>1.4</u> GHz ~ <u>2.0</u> GHz is not applicable for EN61204:2000)
	Field Strength	3V/m
	AM 1kHz	80%
Radio-frequency Electromagnetic Field Keyed Carrier	Frequency Rang	900 ± 5MHz
	Field Strength	3V/m
	Duty Cycle	50%
	Repetition Frequency	200Hz

#### 5 CONFIGURATION OF THE EUT

Same as “Conducted Power Line test”, section 4

#### 6 OPERATION CONDITION OF EUT

Same as “Conducted Power Line test”, section 5

#### 7 TEST CONDITION

7.1 Frequency Step : 1 %, 3 sec. / each step size

7.2 Antenna Polarity : HORIZONTAL & VERTICAL

7.3 The four sides of EUT are tested  
(FRONT, REAR, RIGHT, LEFT)

7.4 Temperature : 27

7.5 Humidity : 60 % RH



## 8 PERFORMANCE CRITERIA

- A. Normal performance within the specification.
- B. Temporary degradation or loss function or performance which is self-recoverable.
- C. Temporary degradation or loss function or performance which requires operator intervention system reset.
- D. Degradation or loss function which is not recoverable due to damage of EUT or software, or loss of data.

## 9 TEST RESULT

ANT SIDE	HORIZONTAL	VERTICAL	RESULT
FRONT	A	A	PASSED
REAR	A	A	PASSED
RIGHT	A	A	PASSED
LEFT	A	A	PASSED

**9 Photos of test configuration please refer to appendix A.**

## ELECTRICAL FAST TRANSIENT/BURST IMMUNITY TEST (EFT)

### 1 TEST INSTRUMENTS & FACILITIES

Instruments/ Facilities	Manufacturer	Model # Serial #	Data Of Cal.
BURST-TESTER	HAEFELY	PEFT/JUNIOR	FEB/2004
CONTROL PC	KB TECH	KB P586/133	--

### 2 TEST PROCEDURE

According to **IEC 61000-4-4 (2004)**

According to **EN 61204-3 (2000)**

### 3 TEST SETUP

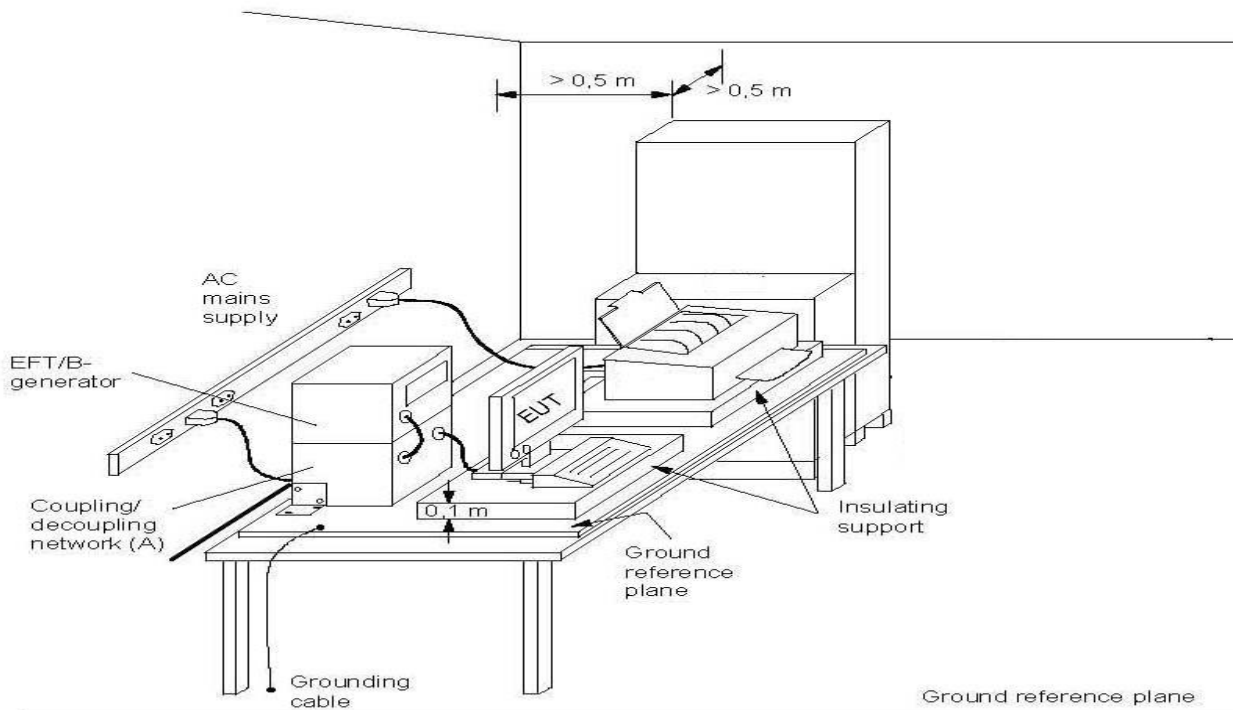

(Details for setup configuration, please refer to appendix A.)

Note: length between clamp and the EUT to be tested (should be  $0.5\text{ m} \pm 0.05\text{ m}$ )

(A) location for supply line coupling

(B) location for signal line coupling



#### 4 CONFIGURATION OF THE EUT

Same as “Conducted Power Line test”, section 4

#### 5 OPERATION CONDITION OF EUT

Same as “Conducted Power Line test”, section 5

#### 6 TEST CONDITION

6.1 Pulse Rise time & Duration : 5 nS / 50 nS

6.2 Pulse Repetition : 5 kHz

6.3 Polarity : POSITIVE / NEGATIVE

6.4 Test Voltage :  $\pm 0.5KV$ ,  $\pm 1KV$

6.5 Coupling of power line :  
L, N, L+N

6.6 Temperature : 27

6.7 Humidity : 60 % RH

#### 7 PERFORMANCE CRITERIA

- A. Normal performance within the specification.
- B. Temporary degradation or loss function or performance which is self-recoverable.
- C. Temporary degradation or loss function or performance which requires operator intervention system reset.
- D. Degradation or loss function which is not recoverable due to damage of EUT or software, or loss of data.



## 8 TEST RESULT

TEST VOLTAGE	L	N	L+N
$\pm 0.5KV$	A	A	A
$\pm 1KV$	A	A	A

8.1 Model : PW408

8.2 Test Mode : Power output of DC 24V mode

8.3 Final Result : PASSED

8.4 Remark :

## 9 Photos of test configuration please refer to appendix A.

## SURGE IMMUNITY TEST

### 1 TEST INSTRUMENTS & FACILITIES

Instruments/ Facilities	Manufacturer	Model # Serial #	Data Of Cal.
SURGER-TESTER	HAEFELY	PSURGE 4010 583334-38	FEB/2004
CONTROL PC	KB TECH	KB P586/133	--

### 2 TEST PROCEDURE

According To **IEC 61000-4-5 (2001)**

According To **EN 61204-3 (2000)**

### 3 TEST SETUP

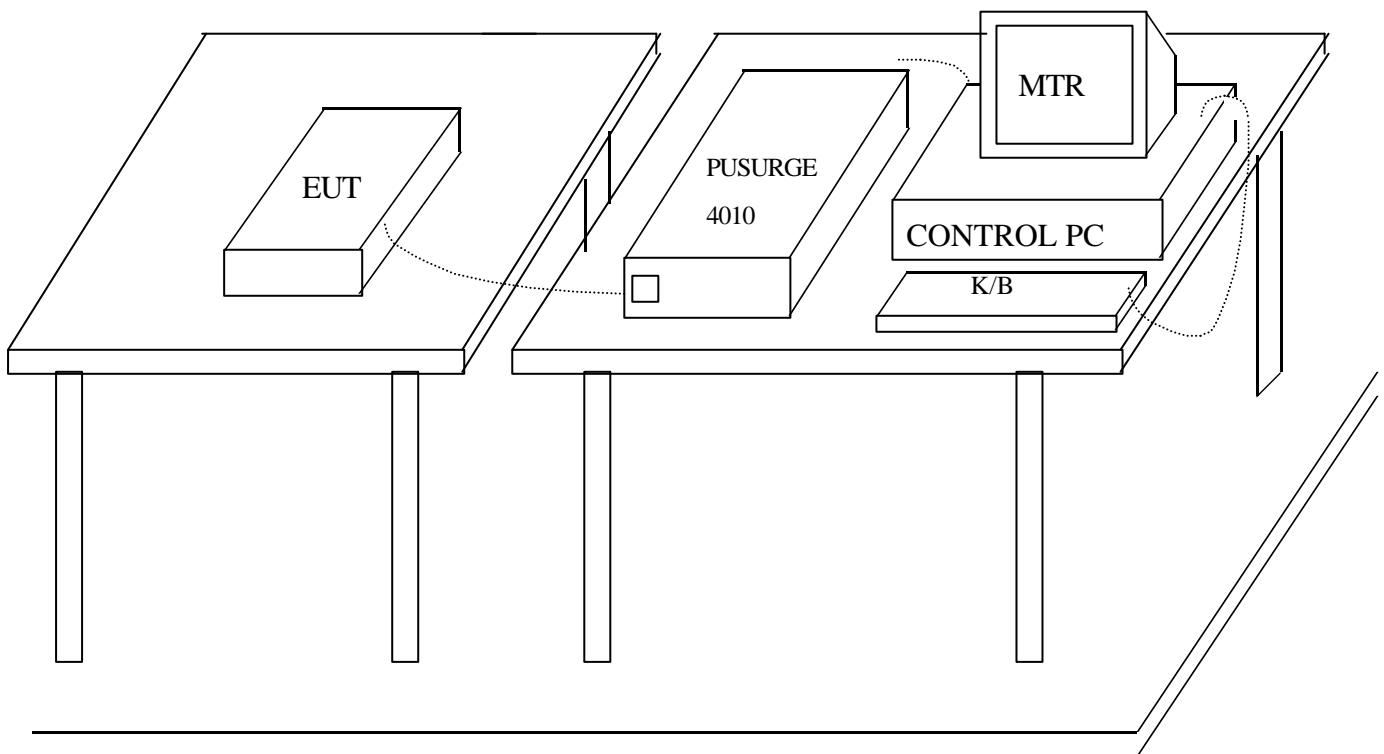

**GROUND PLANE**  
(Details for setup configuration, please refer to appendix A.)



#### 4 TEST LEVELS

- Input and Output AC Power Ports.
- DC Input and DC Output Power Ports.

Environmental Phenomena	Test Specification		Units	Performance Criteria
	AC	DC		
Surges	1.2 / 50 (8/20)		Tr /Th us	
Line to Line	± 1	± 0.5	KV (Charge Voltage)	B

#### 5 CONFIGURATION OF THE EUT

Same as “Conducted Power Line test”, section 4

#### 6 EUT OPERATION CONDITION

Same as “Conducted Power Line test”, section 5

#### 7 CONDITIONS DURING TESTING

7.1 Coupling of power line :

(A) Line to Line ± 1KV (AC) or ± 0.5KV (DC)

7.2 Polarity : POSITIVE / NEGATIVE

7.3 Phase shifting in a range between 0 ° to 360 °

7.4 Repetion rate at least 1 per min

7.5 Temperature : 27 (15 ~ 35 )

Humidity : 60 % RH.(10 % ~ 75%)



8 PERFORMANCE CRITERIA

- A. Normal performance within the specification limits.
- B. Temporary degradation or loss of function or performance which is self-recoverable.
- C. Temporary degradation or loss of function or performance which requires operator intervention or system reset.
- D. Degradation or loss of function which is not recoverable due to damage of equipment (components).

9 TEST RESULT

Environmental Phenomena	Test Specification	Units	Performance
Line to Line	$\pm 1$	KV (Charge Voltage)	A

9.1 Model : PW408

9.2 Test Mode : Power output of DC 24V mode

9.3 Final Result : PASSED

9.4 Remark :

**10 Photos of test configuration please refer to appendix A.**



## IMMUNITY TEST TO CS CONDUCTED DISTURBANCE

### 1 TEST INSTRUMENTS & FACILITIES

Instruments/ Facilities	Manufacturer	Model # Serial #	Date Of Cal.
SIGNAL GENERATOR	ROHDE & SCHWARZ	SMY02 845181/025	MAR/2004
AMPLIFIER	AMPLIFIER RESEARCH	75A250 25680	N/A
RF VOLTMETER	BOONTON	9200C 361701AA	MAR/2004
RF PROBE	BOONTON	952001B 37082	MAR/2004
DIRECTION COUPLER	AMPLIFIER RESEARCH	DC2600 20508	N/A
COUPLING DECOUPLING NETWORK	FCC	FCC-801-M3-25A 9993	FEB/2004
CONTROL PC	KB TECH	KB P586/133	--

### 2 TEST PROCEDURE

According To **IEC 61000-4-6 (2003) + A1 (2004)**

According To **EN 61204-3 (2000)**

### 3 TEST SETUP

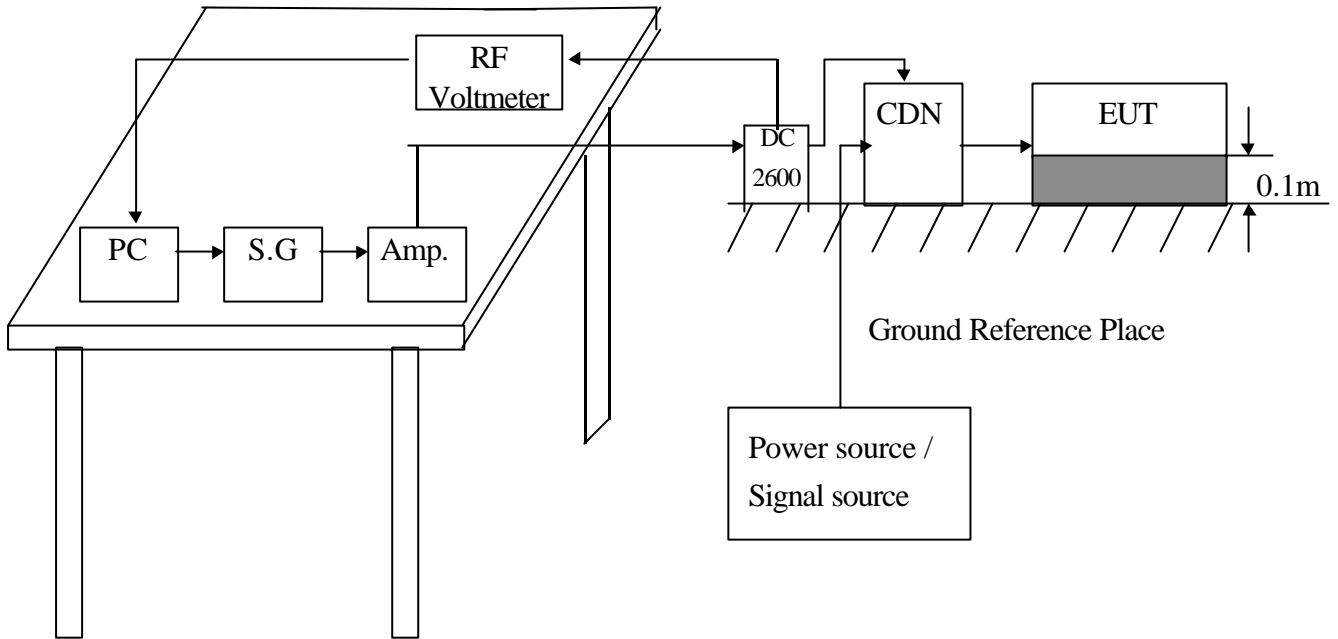

(Details for setup configuration, please refer to appendix A.)



#### 4 TEST LEVELS

- Ports for signal lines and control lines.
- DC input and DC output power ports.
- Input and Output AC Power Ports.
- Functional earth Ports.

Environmental	Test Specification	Units	Performance
Radio-frequency	0.15 - 80	MHz	A
Common mode	3	V	
	80	% AM (1KHz)	

#### 5 CONFIGURATION OF THE EUT

Same as “Conducted Power Line test”, section 4

#### 6 EUT OPERATION CONDITION

Same as “Conducted Power Line test”, section 5

#### 7 CONDITIONS DURING TESTING

7.1 The EUT tested type :

- Single unit
- Multiple unit

7.2 Dwell time : < 1%

7.3 Temperature : 27 (15 ~ 35 )  
 Humidity : 60 % RH.(10 % ~ 75%)



### 8 PERFORMANCE CRITERIA

- A. Normal performance within the specification limits.
- B. Temporary degradation or loss of function or performance which is self-recoverable.
- C. Temporary degradation or loss of function or performance which requires operator intervention or system reset.
- D. Degradation or loss of function which is not recoverable due to damage of equipment (components).

### 9 TEST RESULT

TEST Specification	Unit	Performance Criteria
0.15 - 80	MHz	A
3	V	
80	% AM (1KHz)	

9.1 Model :     PW408    

9.2 Test Mode :     Power output of DC 24V mode    

9.3 Final Result :     PASSED    

9.4 Remark :

### 10 Photos of test configuration please refer to appendix A.

## VOLTAGE DIPS, SHORT INTERRUPTIONS IMMUNITY TEST

### 1 TEST INSTRUMENTS & FACILITIES

Instruments/ Facilities	Manufacturer	Model # Serial #	Data Of Cal.
LINE INTERFERENCE -TESTER	HAEFELY	PLINE 1610 080166-10	MAR/2004
CONTROL PC	KB TECH	KB P586/133	--

### 2 TEST PROCEDURE

According To **IEC 61000-4-11 (2004)**

According To **EN 61204-3 (2000)**

### 3 TEST SETUP

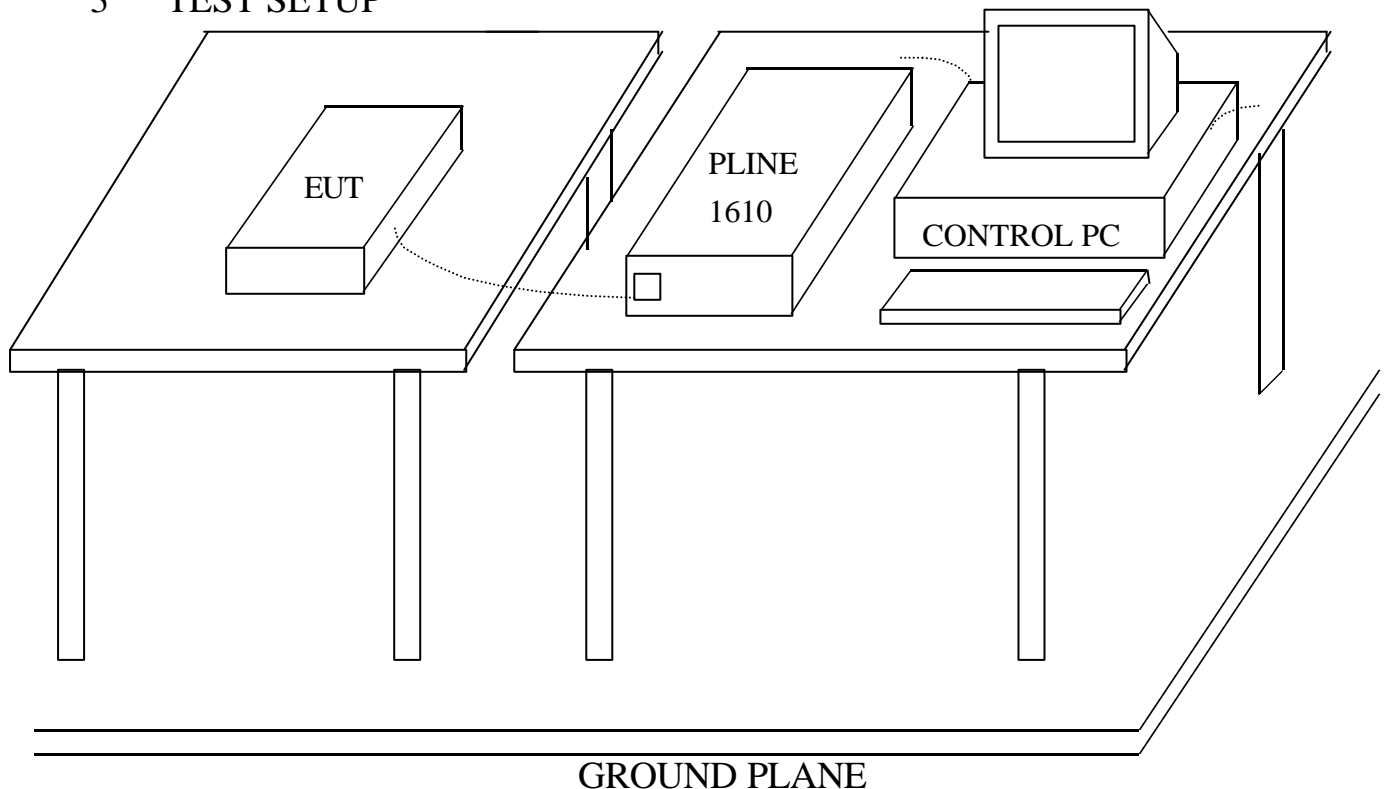

(Details for setup configuration, please refer to appendix A.)

#### 4 TEST LEVELS

##### Input and Output AC Power Ports.

- Voltage Dips.
- Voltage Interruptions.

Class <sup>a</sup>	Test level and durations for voltage dips				
Class 1	Case-by-case according to the equipment requirements				
Class 2	0 % during 1/2 cycle	0 % during 1 cycle	70 % during 25/30 <sup>c</sup> cycles		
Class 3	0 % during 1/2 cycle	0 % during 1 cycle	40 % during 10/12 <sup>c</sup> cycles	70 % during 25/30 <sup>c</sup> cycles	80 % during 250/300 <sup>c</sup> cycles
a: Classes as per IEC 61000-2-4. b: To be defined by product committee. For equipment connected directly or indirectly to the public network, the levels must not be less severe than Class 2. c: “25/30 cycles” means “25 cycles for 50 Hz test” and “30 cycles for 60 Hz tet”.					

Class <sup>a</sup>	Test level and durations for short interruptions (t <sub>s</sub> ) (50Hz / 60Hz)
Class 1	Case-by-case according to the equipment requirements
Class 2	0 % during 250/300 <sup>c</sup> cycles
Class 3	0 % during 250/300 <sup>c</sup> cycles
Class X <sup>b</sup>	X
a: Classes as per IEC 61000-2-4. b: To be defined by product committee. For equipment connected directly or indirectly to the public network, the levels must not be less severe than Class 2. c: “250/300 cycles” means “250 cycles for 50 Hz test” and “300 cycles for 60 Hz test”.	

**According to the specification of EUT, Class 2 is applied.**

#### 5 CONFIGURATION OF THE EUT

Same as “Conducted Power Line test”, section 4

#### 6 EUT OPERATION CONDITION

Same as “Conducted Power Line test”, section 5

#### 7 CONDITIONS DURING TESTING

7.1 Temperature : 27 (15 ~ 35 )  
 Humidity : 60 % RH.(25 % ~ 75%)



### 8 PERFORMANCE CRITERIA

- A. Normal performance within the specification limits.
- B. Temporary degradation or loss of function or performance which is self-recoverable.
- C. Temporary degradation or loss of function or performance which requires operator intervention or system reset.
- D. Degradation or loss of function which is not recoverable due to damage of equipment (components).

### 9 TEST RESULT

Environmental Phenomena	Test Specification	Units	Perform Criteria
Voltage Dips	0	% during	A
	1/2	Cycle	
	0	% during	C
	1	Cycle	
Voltage Short Interruptions	70	% during	C
	25	Cycles	
Voltage Short Interruptions	0	% during	C
	250	Cycles	

9.1 Model : PW408

9.2 Test Mode : Power output of DC 24V mode

9.3 Final Results : PASSED

9.4 Remark :

### 10 Photos of test configuration please refer to appendix A.



HomeTek Technology Inc.

**Appendix A**  
**PHOTOS OF TEST CONFIGURATION**



### PHOTO OF CONDUCTED POWER LINE TEST

Test Mode : DC 24V MODE , Model: PW408



Front View



Rear View

## PHOTO OF RADIATED EMISSION TEST

Test Mode : DC 24V MODE , Model: PW408

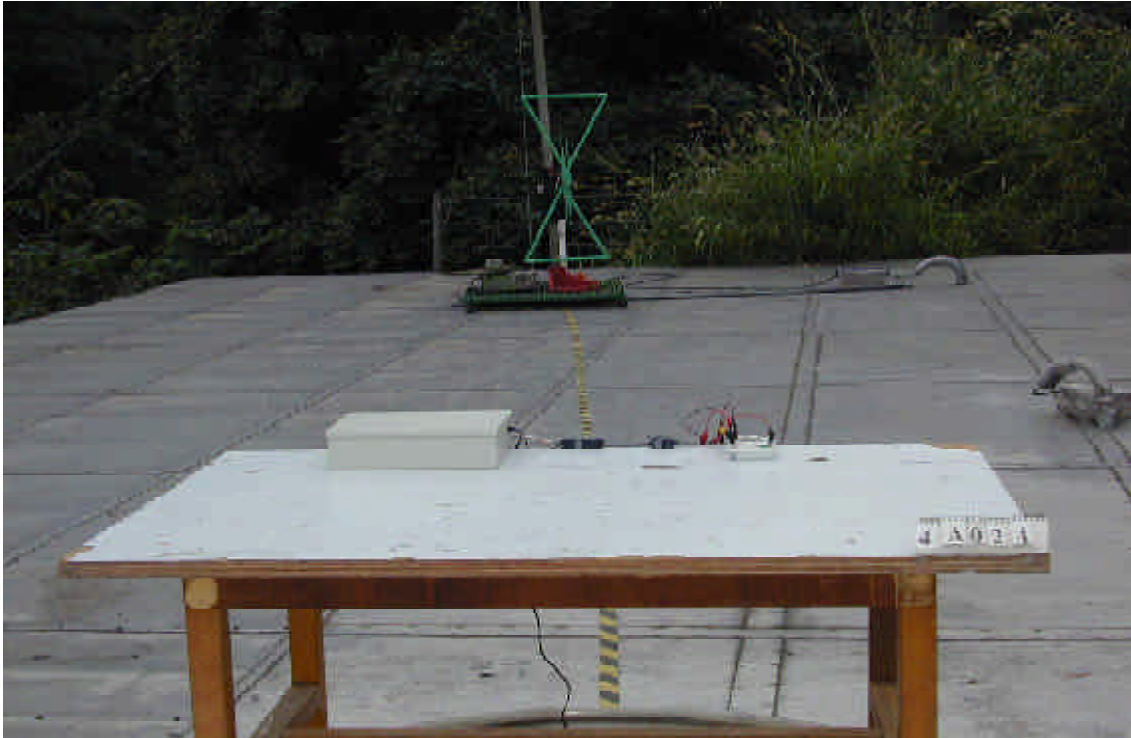

Front View

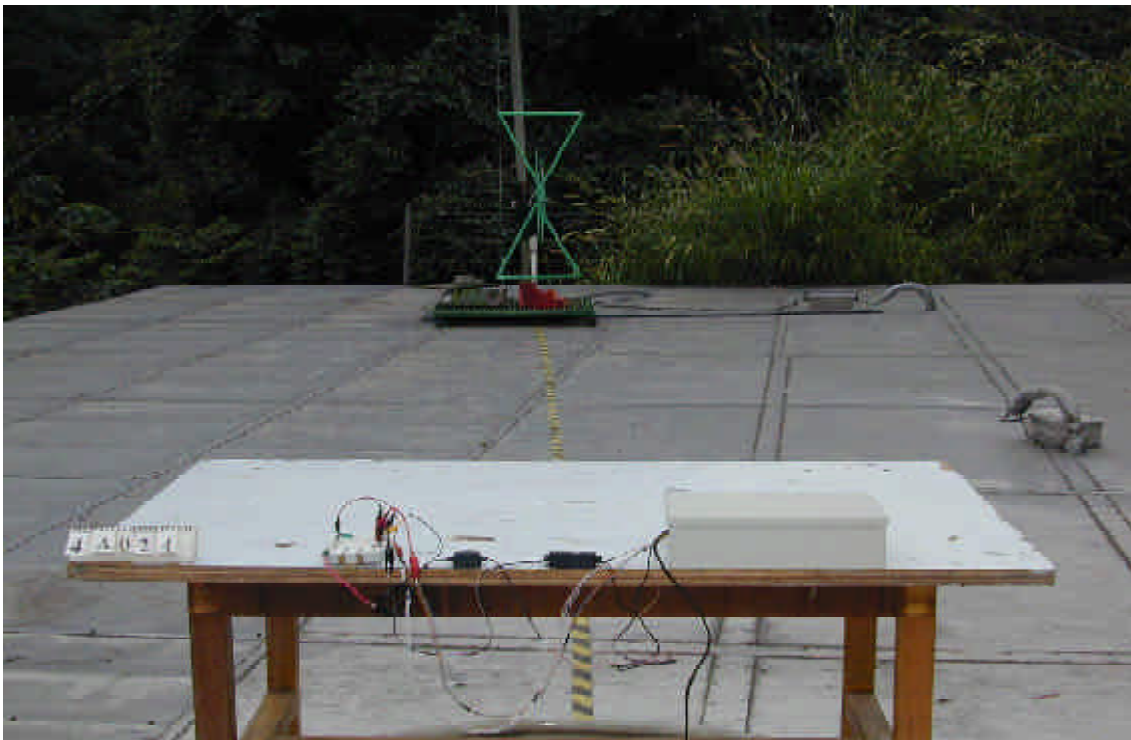

Rear View



**PHOTO OF HARMONICS & VOLTAGE FLUCTUATIONS TEST  
AND SURGE IMMUNITY TEST AND VOLTAGE DIPS, SHORT  
INTERRUPTIONS IMMUNITY TEST**

Test Mode : DC 24V MODE , Model: PW408



**PHOTO OF ELECTRICAL FAST TRANSIENT/BURST IMMUNITY  
TEST**





HomeTek Technology Inc.

**PHOTO OF ELECTROSTATIC DISCHARGE IMMUNITY TEST  
(ESD)**

Test Mode : DC 24V MODE , Model: PW408



Front View

**PHOTO OF RADIO FREQUENCY ELECTROMAGNETIC FIELD IMMUNITY TEST (RS)**

Test Mode : DC 24V MODE , Model: PW408

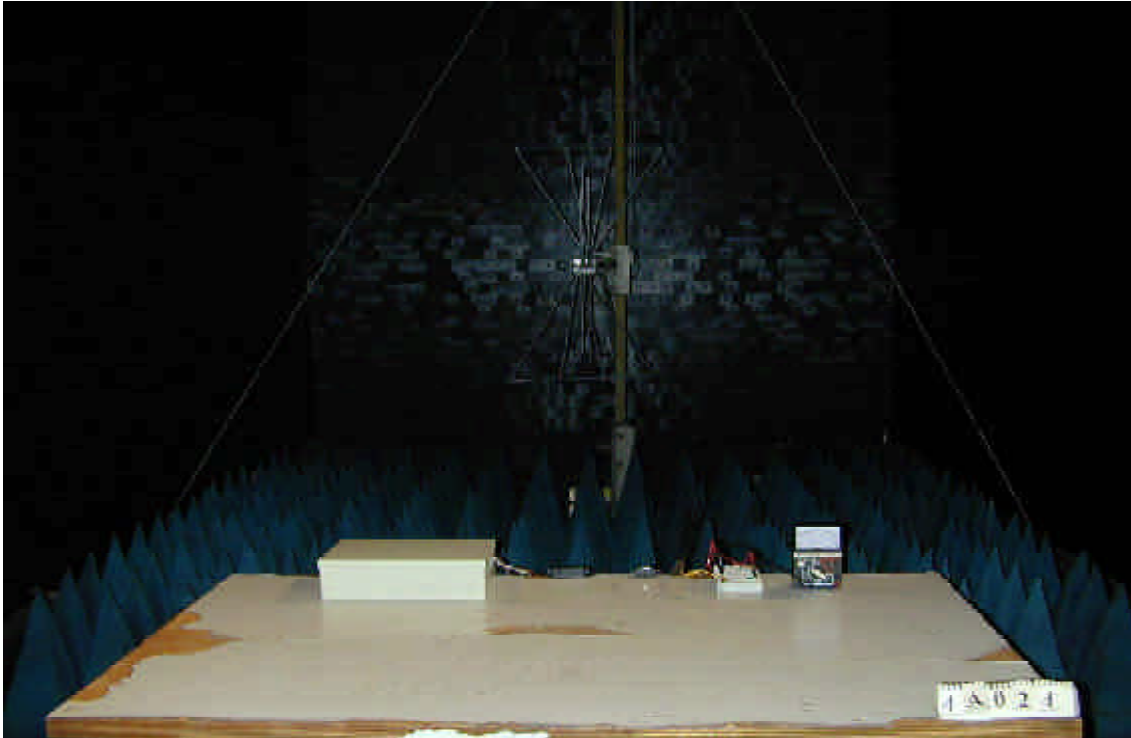

**PHOTO OF CS CONDUCTED DISTURBANCE IMMUNITY TEST**

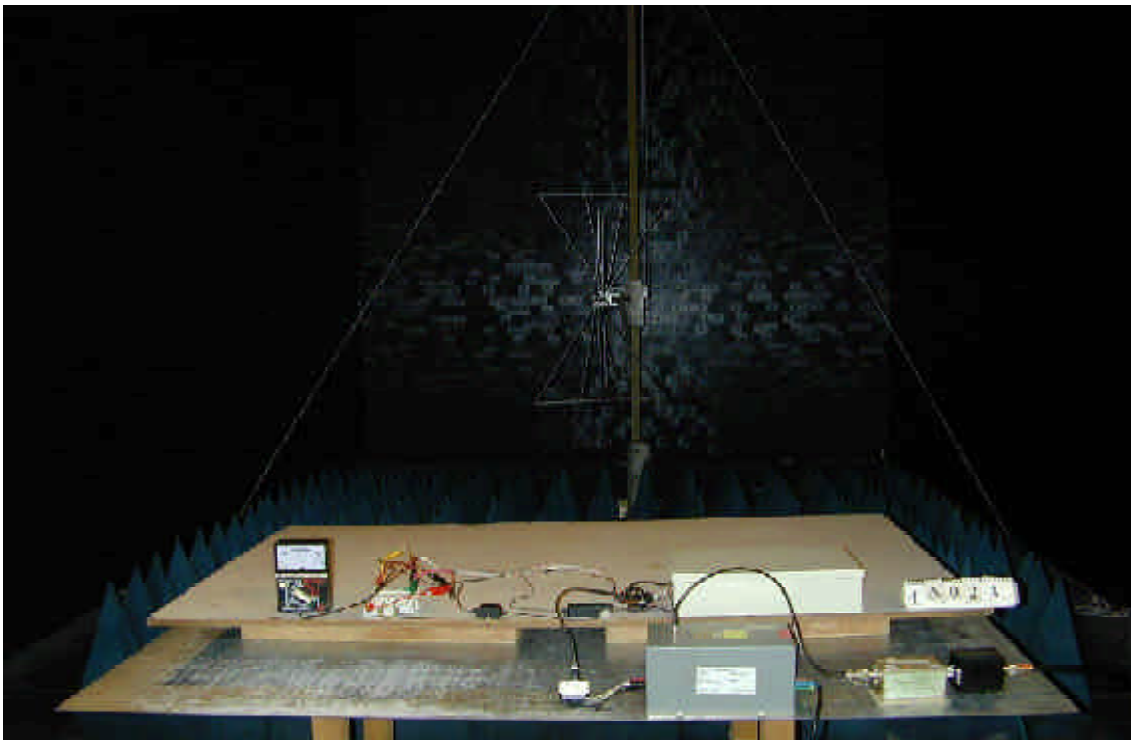



HomeTek Technology Inc.

**Appendix B**  
**PHOTOS OF EUT**

### PHOTO OF EUT

Model : PW408



Full View of EUT

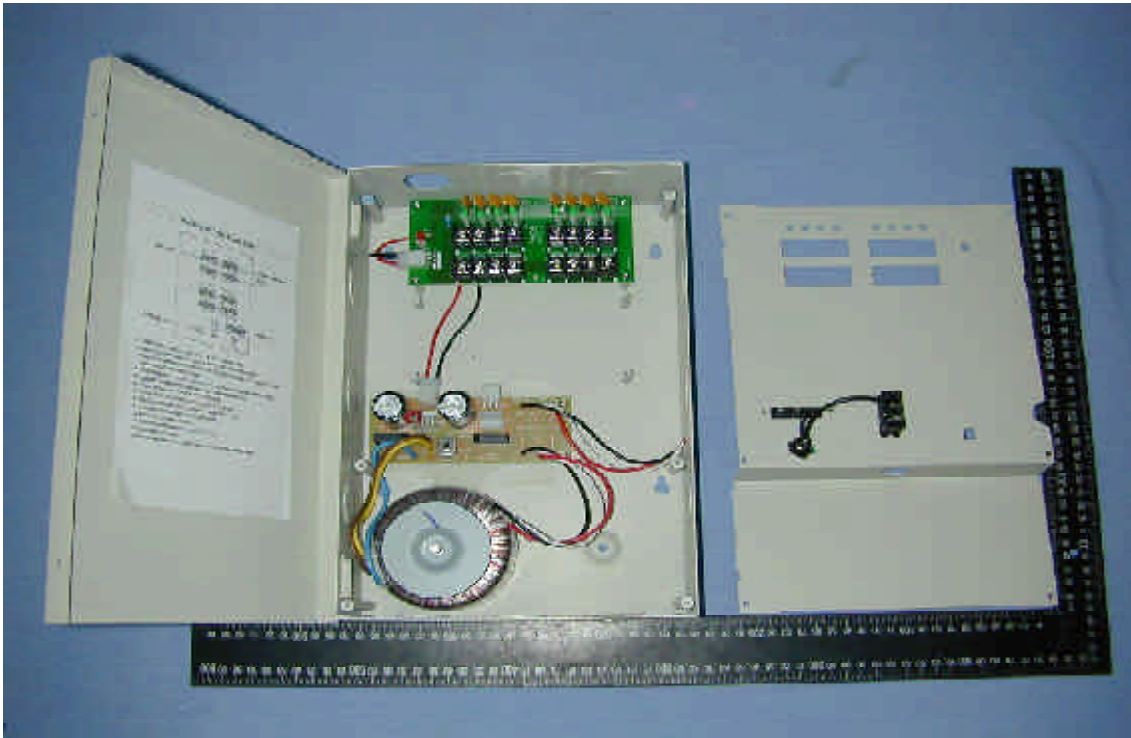

Inside View of EUT

### PHOTO OF EUT

Model : PW408

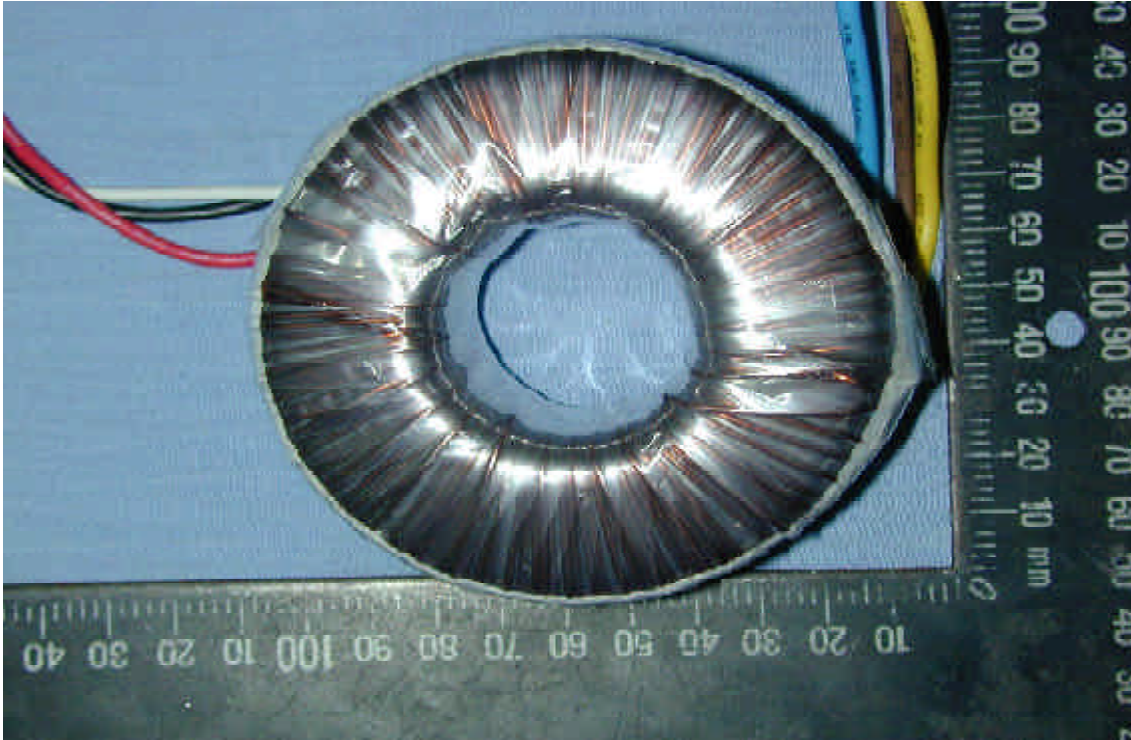

Full View of Transformer

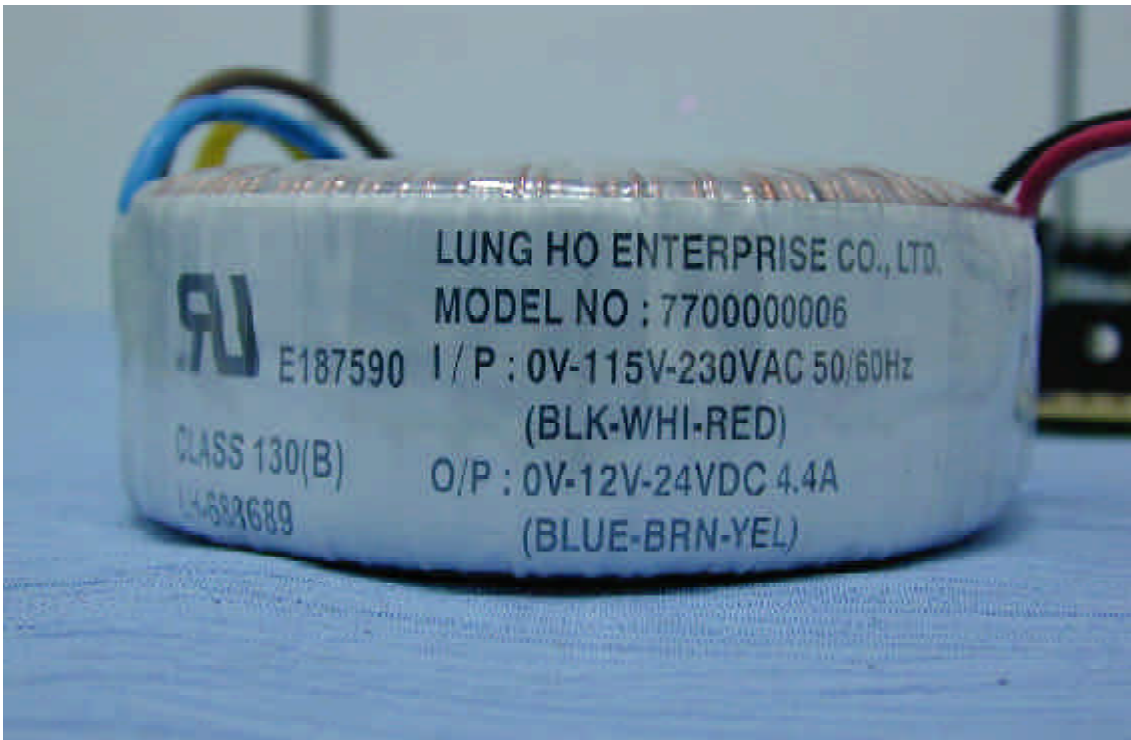

Full View of Transformer

### PHOTO OF EUT

Model : PW408X-XXX

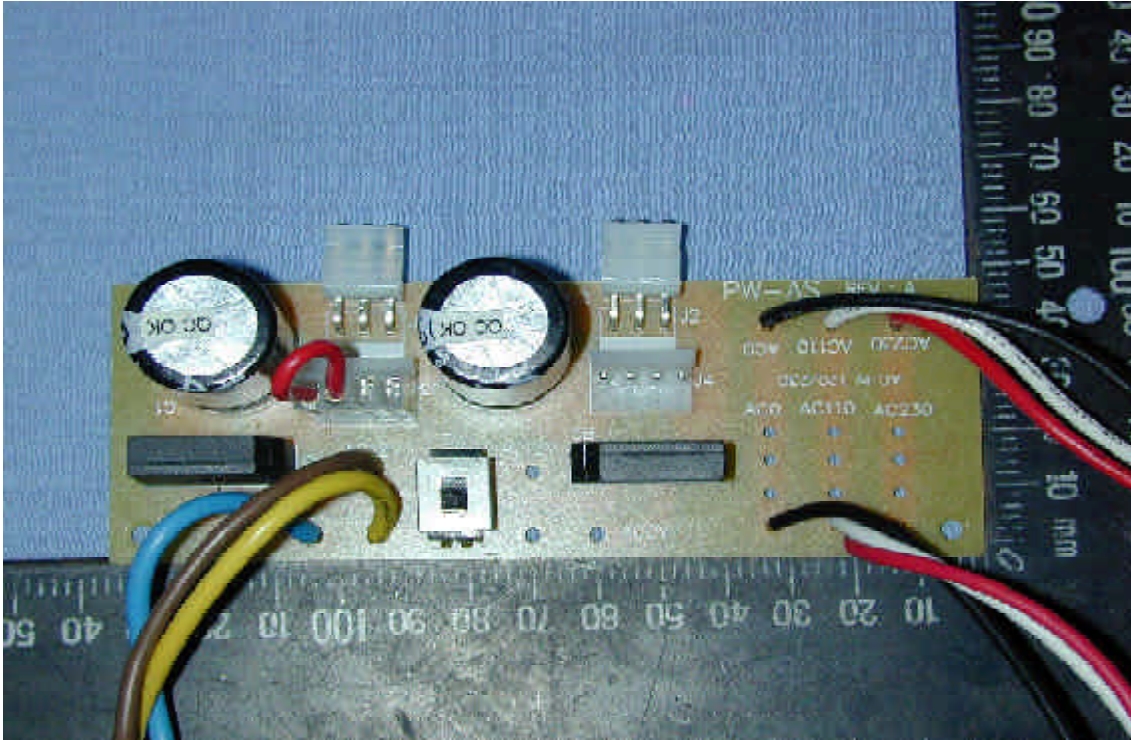

Component Side of Main Board - 1

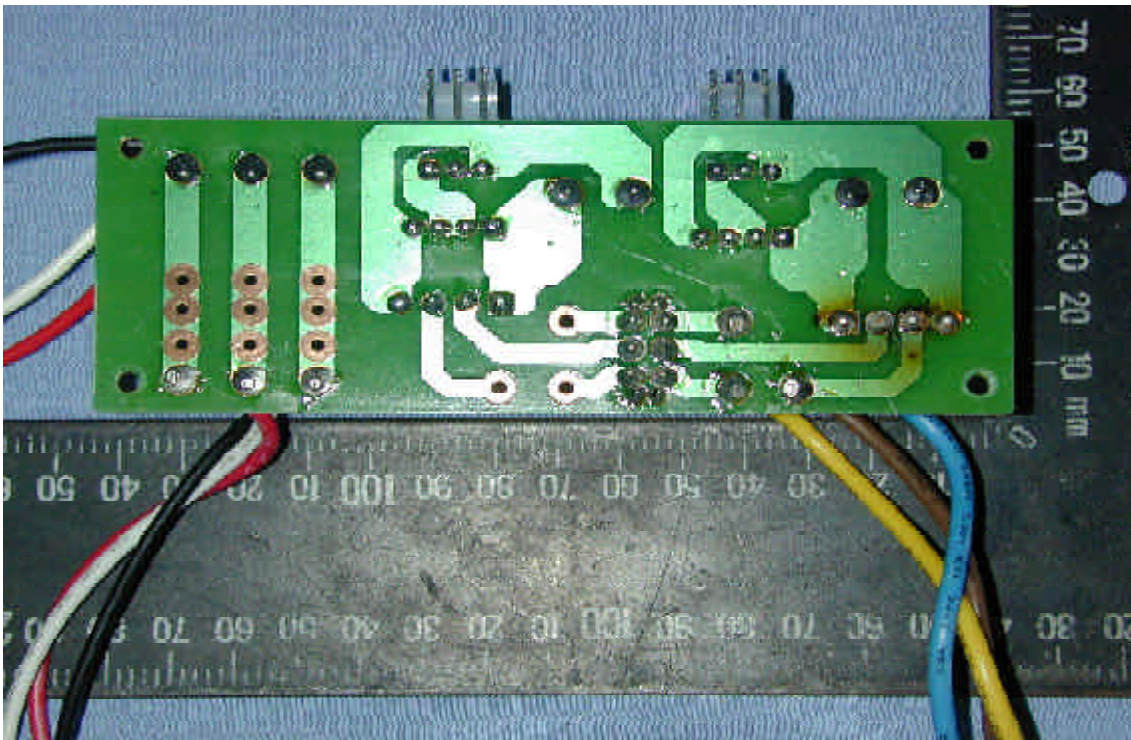

Solder Side of Main Board - 1

### PHOTO OF EUT

Model : PW408X-XXX

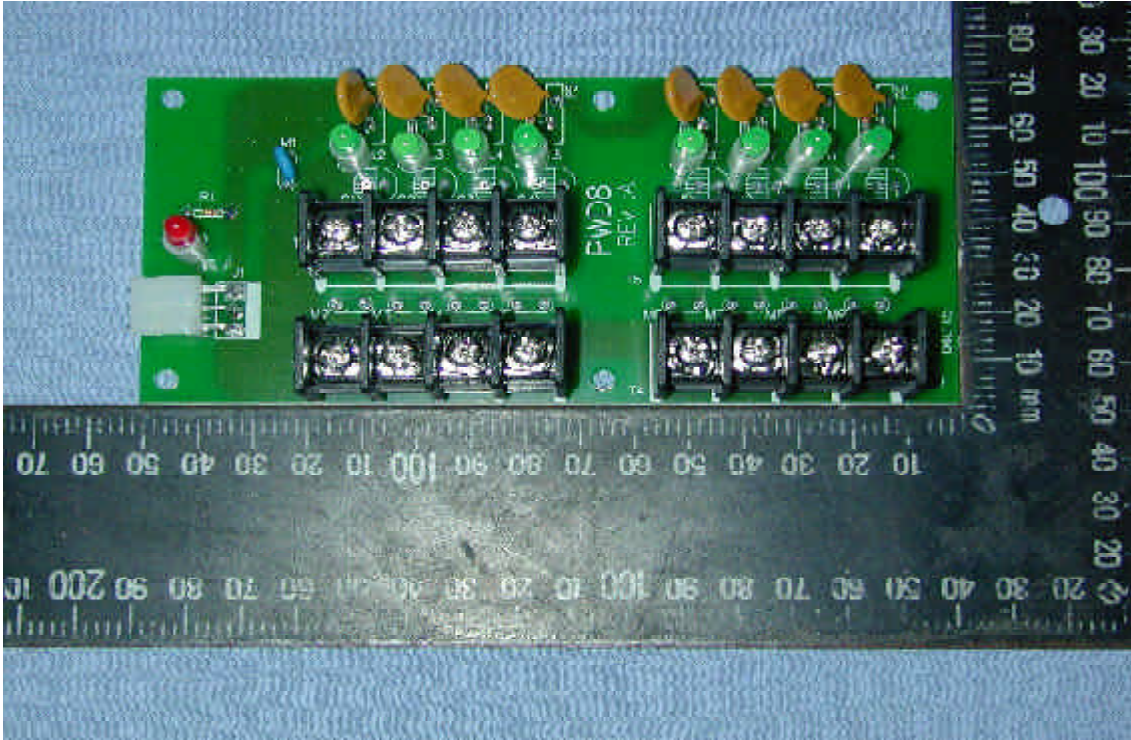

Component Side of Main Board - 2

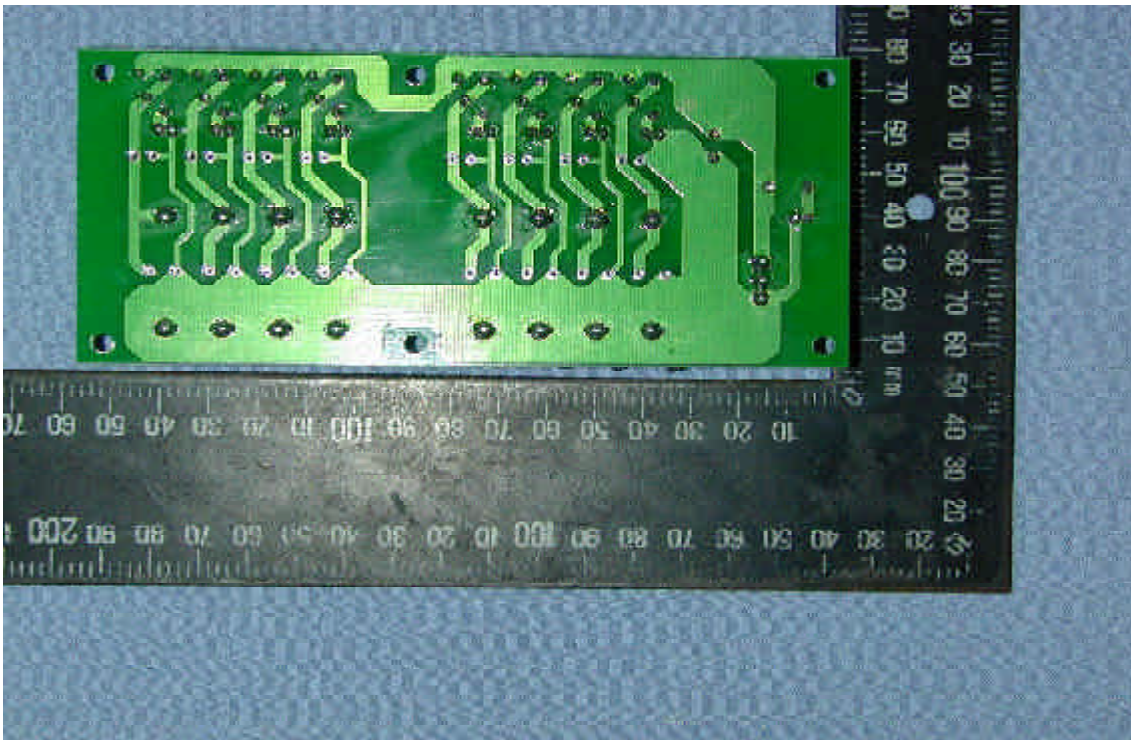

Solder Side of Main Board - 2

# Declaration of Conformity

We(Manufacturer/Importer)

---

(company name)

---

(address)

declares under our sole responsibility that the product

Product name : Power Supply

Model No. : PW408X-XXX

to which this declaration relates is in conformity with the following standard(s) or other normative document(s)

- |  |        |  |        |
|--|--------|--|--------|
| <input checked="" type="checkbox"/> EN 61204-3   | (2000) | <input checked="" type="checkbox"/> IEC 61000-4-2  | (2001) |
| <input checked="" type="checkbox"/> CISPR 22     | (1997) | <input checked="" type="checkbox"/> IEC 61000-4-3  | (2002) |
| <input checked="" type="checkbox"/> EN 61000-3-2 | (2000) | <input checked="" type="checkbox"/> IEC 61000-4-4  | (2004) |
| <input checked="" type="checkbox"/> EN 61000-3-3 | (1995) | <input checked="" type="checkbox"/> IEC 61000-4-5  | (2001) |
| + A1   | (2001) | <input checked="" type="checkbox"/> IEC 61000-4-6  | (2003) |
|  |        | + A1   | (2004) |
|  |        | <input checked="" type="checkbox"/> IEC 61000-4-11 | (2004) |

following the provisions of 89/336/EEC Directive

Place: \_\_\_\_\_ Signature: \_\_\_\_\_

Date : \_\_\_\_\_ Full name: \_\_\_\_\_



Title: \_\_\_\_\_



TÜV Rheinland Taiwan Ltd.

# Certificate of Appointment

for the applicant:

**Hometek Technology Inc.**  
No. 67-9, Shir Men Rd., Tu-Cheng City,  
Taipei Hsien 236, Taiwan, R.O.C.

has been authorized to carry out EMC tests by order and under supervision of TÜV Rheinland. It has successfully demonstrated capability to conduct measurement and to process test data according to:

**European and International EMC Standards as listed in the  
Scope of Authorization on the attachment to this certificate**

An assessment of the facility was conducted by TÜV Rheinland auditors according to the TÜV Rheinland requirements for "Test Site Approval" with reference to  
**ISO 17 025:1999**

Certificate No. : 10012161-2004

Valid until : February 14, 2006

TÜV Rheinland Taiwan Ltd.  
Taipei, December 21, 2004

  
Dipl.-Ing. Andreas Klinker  
Certification Body

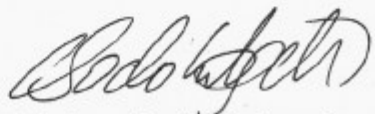
  
Dipl.-Ing. Bodo Kretschmar  
Product Safety and Quality



Attachment to  
**Certificate**  
of Appointment

SCOPE OF AUTHORIZATION

**Hometek Technology Inc.**  
No. 67-9, Shir Men Rd., Tu-Cheng City,  
Taipei Hsien 236, Taiwan, R.O.C.

**European Standards**

EN 50081-1	EN 61000-3-2	ENV 50140
EN 50081-2	EN 61000-3-3	ENV 50141
EN 50082-1	EN 61000-6-1	ENV 50204
EN 50130-4	EN 61000-6-2	
EN 50091-2	EN 61000-6-3	
EN 55011	EN 61000-6-4	
EN 55013	EN 61000-3-11	
EN 55014-1	EN 61000-4-2	
EN 55014-2	EN 61000-4-3	
EN 55022	EN 61000-4-4	
EN 55024	EN 61000-4-5	
EN 60601-1-2	EN 61000-4-6	
EN 60801	EN 61000-4-8	
EN 60945	EN 61000-4-11	
	EN 61204-3	

**International Standards**

CISPR 11	IEC 61000-4-2	IEC 61000-3-2
CISPR 13	IEC 61000-4-3	IEC 61000-3-3
CISPR 14-1	IEC 61000-4-4	IEC 61000-3-11
CISPR 14-2	IEC 61000-4-5	IEC 61000-6-1
CISPR 22	IEC 61000-4-6	IEC 61000-6-2
CISPR 24	IEC 61000-4-8	IEC 61000-6-3
	IEC 61000-4-11	IEC 61000-6-4
IEC 801.2	IEC 61000-4-12	IEC 60945
IEC 801.3		
IEC 801.4		

Certificate No. : 10012161-2004

Taipei, December 21 , 2004

Dipl.-Ing. Bodo Krätzschar  
Product Safety and Quality