

HomeTek Technology Inc.

ADDRESS: No. 67-9, Shir Men Road, Tu Cheng City,  
Taipei Hsien, Taiwan, R. O. C.

PHONE : 886-2-22608375 FAX : 886-2-22748013

E - mail : hometek@ms15.hinet.net

## FCC TEST REPORT FOR

APPLICANT : SMART CABLING & TRANSMISSION CORP.  
ADDRESS : 7F-1, NO. 168, LIEN CHENG RD.,  
CHUNG-HO CITY, TAIPEI HSIEN, TAIWAN, R. O. C.  
EUT : Transmission  
MODEL NO. : TTA111XXX



NVLAP Lab Code:200331-0

Accredited by the National Voluntary Laboratory Accreditation Program  
for the specific scope of accreditation under Lab Code 200331-0

### MEASUREMENT PROCEDURE USED

FCC RULES AND CISPR 22 (DOCKET NO. 92-152, SEP. 1993) AND FCC / ANSI C63.4-2001

PREPARED BY :

HomeTek Technology Inc.

No. 67-9, Shir Men Road, Tu Cheng City,

Taipei Hsien. Taiwan, R. O. C.

Report # : FD3L026



**TABLE OF CONTENTS** ..... 2

**VERIFICATION**..... 3

**GENERAL INFORMATION** ..... 4

**MODIFICATION LIST** ..... 6

**CONDUCTED POWER LINE TEST**..... 7

    1    TEST INSTRUMENTS & FACILITIES ..... 7

    2    TEST PROCEDURE..... 7

    3    TEST SETUP ..... 8

    4    CONFIGURATION OF THE EUT ..... 10

    5    EUT OPERATING CONDITION..... 14

    6    LIMIT OF CONDUCTED POWER LINE EMISSION CLASS B..... 14

    7    RESULT OF CONDUCTED POWER LINE TEST..... 14

    8    CONDUCTED POWER LINE TEST DATA (PAGE 1)..... 15

    9    CONDUCTED POWER LINE TEST DATA (PAGE 2)..... 16

    10   CONDUCTED POWER LINE TEST DATA (PAGE 3)..... 17

    11   CONDUCTED POWER LINE TEST DATA (PAGE 4)..... 18

**RADIATED EMISSION TEST**..... 19

    1    TEST INSTRUMENTS & FACILITIES ..... 19

    2    TEST PROCEDURE..... 20

    3    TEST SETUP ..... 20

    4    CONFIGURATION OF THE EUT ..... 22

    5    EUT OPERATING CONDITION..... 22

    6    LIMIT OF RADIATED EMISSION CLASS B ..... 22

    7    RESULT OF RADIATED EMISSION TEST ..... 23

    8    RADIATED EMISSION TEST DATA (PAGE 1) ..... 24

    9    RADIATED EMISSION TEST DATA (PAGE 2) ..... 25

**SAMPLE OF FCC LABEL**..... 26

**APPENDIX A**

PHOTOS OF TEST CONFIGURATION

**APPENDIX B**

PHOTOS OF EUT



ADDRESS: No. 67-9, Shir Men Road, Tu Cheng City,  
Taipei Hsien, Taiwan, R. O. C.  
PHONE : 886-2-22608375 FAX : 886-2-22748013  
E - mail : hometek@ms15.hinet.net



## VERIFICATION

for  
FCC Part 15, Subpart B Class B

APPLICANT : SMART CABLING & TRANSMISSION CORP.  
ADDRESS : 7F-1, NO. 168, LIEN CHENG RD.,  
CHUNG-HO CITY, TAIPEI HSIEN, TAIWAN, R. O. C.  
Receipt Date : 12/13/2004 Final Test Date: 12/20/2004  
EUT : Transmission  
MODEL NO. : TTA111XXX

### MEASUREMENT PROCEDURE USED :

FCC RULES AND CISPR 22 (DOCKET NO. 92-152, SEP. 1993)  
AND FCC / ANSI C63.4-2001

TEST PROCEDURE AND DATA ARE TRACEABLE TO NIST/USA,  
TL or NML/TAIWAN.

- THE MAXIMUM EMISSION LEVELS WERE COMPARED TO THE CISPR 22 CLASS B LIMITS BOTH RADIATED AND CONDUCTED EMISSION.
- THE ABOVE DEVICE WAS TESTED BY HOMETEK TECHNOLOGY INC. TO SHOWS THE MAXIMUM EMISSION LEVEL FROM THE DEVICE.
- THIS TEST RESULTS OF THIS REPORT APPLIES TO ABOVE TESTED SAMPLE ONLY.
- THIS TEST REPORT SHALL NOT BE REPRODUCE IN PART WITHOUT WRITTEN APPROVAL OF HOMETEK TECHNOLOGY INC.
- THE REPORT MUST NOT BE USED BY THE CLIENT TO CLAIM PRODUCT ENDORSEMENT BY NVLAP OR ANY AGENCY OF THE U. S. GOVERNMENT.
- THE TEST RESULTS ARE TRACEABLE TO THE NATIONAL OR INTERNATIONAL STANDARD.

PREPARED BY :  DATE : 1/26/2005  
FRANKIE WANG

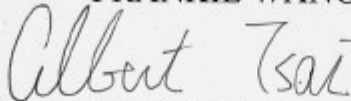
CHECK BY :  DATE : 1/26/2005  
ALBERT TSAI / Senior Engineer

APPROVED BY :  DATE : 1/26/2005  
TOMMY RAU / Manager

**GENERAL INFORMATION**

- 1 APPLICANT : SMART CABLING & TRANSMISSION CORP.
- 2 ADDRESS : 7F-1, No. 168, Lien Cheng Rd.,  
Chung-Ho City, Taipei Hsien, Taiwan, R. O. C.
- 3 MANUFACTURER : SMART CABLING & TRANSMISSION CORP.
- 4 ADDRESS : 7F-1, No. 168, Lien Cheng Rd.,  
Chung-Ho City, Taipei Hsien, Taiwan, R. O. C.
- 5 DESCRIPTION OF EUT :
  - EUT : Transmission
  - FCC ID : N/A
  - Model Number : TTA111XXX
  - Serial # : N/A

5.1 The difference between series of models TTA111XXX is shown as below:

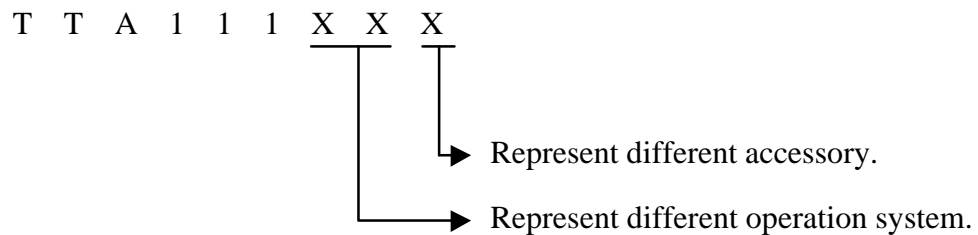

The worst case of EMI test model is TTA111VT and the final test data were shown in this test report.



6 FEATURES OF EUT :

**Please refer to user manual or product specification.**



HomeTek Technology Inc.

## **MODIFICATION LIST**

THE FOLLOWING ACCESSORIES WERE ADDED TO THE EUT DURING TESTING :

NO MODIFICATION BY HOMETEK TECHNOLOGY INC.

## CONDUCTED POWER LINE TEST

### 1 TEST INSTRUMENTS & FACILITIES

The following test Instruments was used during the conducted test :

Item	Instruments/ Facilities	Specification	Manufacturer	Model # S/N	Date Of Cal.
1	EMI Receiver	9KHz ~ 30MHz	ROHDE & SCHWARZ	ESHS 30 844827/007	MAR/2004
2	LISN (for EUT)	50 /50uH/100A 150KHz ~ 30MHz	SCHWARZ BECK	NNLK 8121 8121370	OCT/2004
3	LISN (for Support Unit)	50 /50uH/10A 9KHz ~ 30MHz	ROHDE & SCHWARZ	ESH3-Z5 846128/007	FEB/2004
4	Terminator	50	N/A	N/A	NOV/2004
5	Attenuation	50 /10dB	Mini-Circuit	NAT-10 AT-002	JUL/2004
6	Cable	5.4m	SUHNER	RG-223 CON2-002	AUG/2004
7	ESXS-K1 (software)	Version 2.03b 9KHz ~ 30MHz	ROHDE & SCHWARZ	1082.9678.02 840.913/246	N/A

Note : Items 1 ~ 6 were calibrated within period of 1 year.

### 2 TEST PROCEDURE

- 2.1 The EUT was tested according to **ANSI C63.4 - 2001 & CISPR 22**.
- 2.2 The EUT was placed 0.4 meter from the conducting wall of shielding room and kept at least 0.8 meter from any other grounded conducting surface.
- 2.3 The frequency range form 0.15 MHz to 30 MHz was investigated.
- 2.4 The LISN used was 50 Ohm / 50 uHenry as specified by Section 5.1 of **ANSI C63.4 - 2001**.
- 2.5 All the support peripherals are connect to the other LISN.
- 2.6 Cables and peripherals were moved to find the maximum emission levels for each frequency.

### 3 TEST SETUP

#### 3.1 Typical : Setup Of Conducted Test

ELECTRICAL AND ELECTRONIC EQUIPMENT IN THE RANGE OF 9kHz TO 40 GHz

ANSI  
C63.4-2001

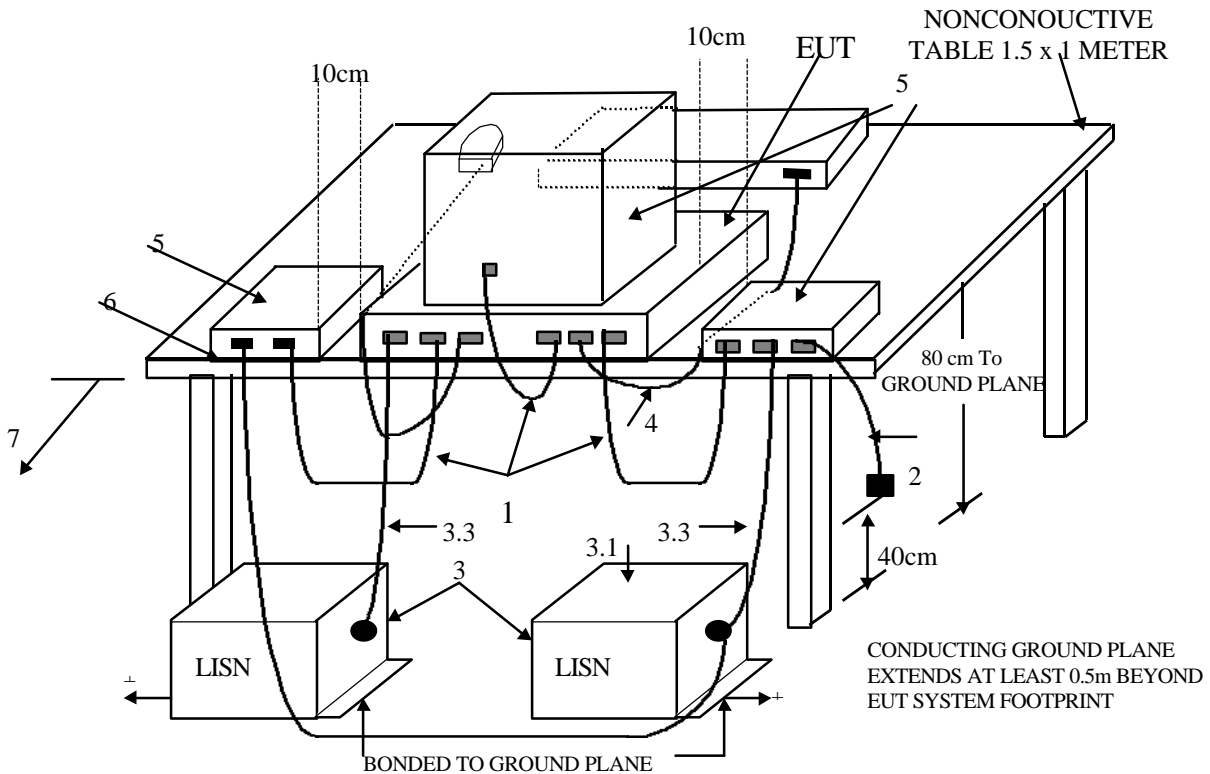

+LISNs may have to be moved to the side to meet 3.3 below.

(Details for setup configuration, please refer to appendix A.)

**LEGEND:**

1. Interconnecting cables that hang closer than 40 cm to the ground plane shall be folded back and forth forming a bundle 30 to 40 cm long, hanging approximately in the middle between ground plane and table.
2. I/O cables that are connected to a peripheral shall be bundled in center. The end of the cable may be terminated if required using correct terminating impedance. The total length shall not exceed 1m.
3. EUT connected to one LISN. Unused LISN connectors shall be terminated in 50 Ω. LISN can be placed on top of, or immediately beneath, ground plane.
  - 3.1 All other equipment powered from second LISN.
  - 3.2 Multiple outlet strip can be used for multiple power cords of non-EUT equipment.
  - 3.3 LISN at least 80 cm from nearest part of EUT chassis.
4. Cables of hand-operated devices, such as keyboards, mice, etc., have to be placed as close as possible to the host.
5. Non-EUT components being tested.
6. Rear of EUT, including peripherals, shall be all aligned and flush with rear of tabletop.
7. Rear of tabletop shall be 40 cm removed from a vertical conducting plane that is bonded to the floor ground plane (see 5.2).

**Test Configuration  
Tabletop Equipment Conducted Emission**

### 3.2 Block Diagram Of Conducted Test

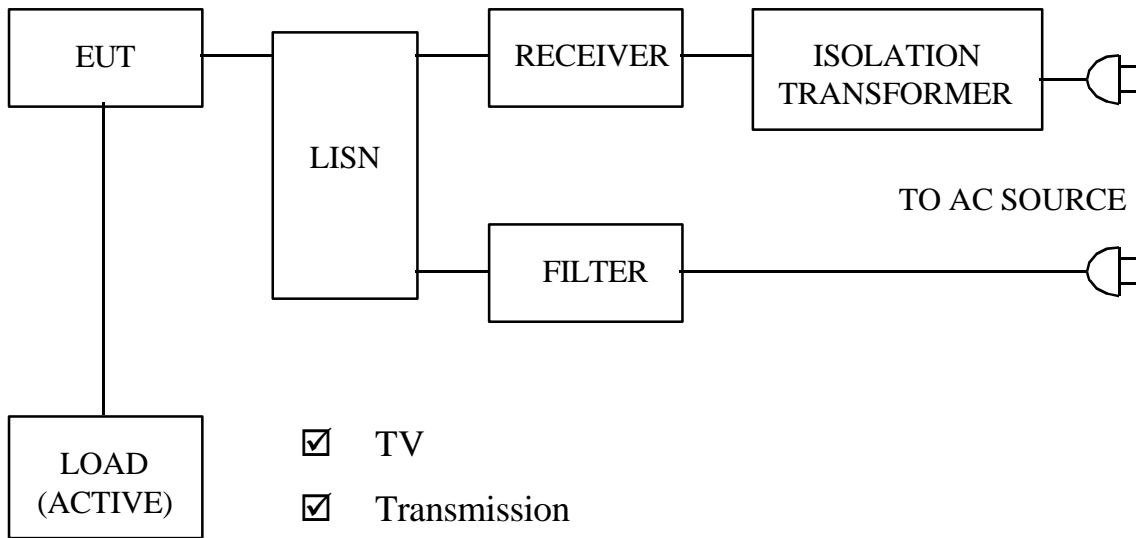

#### 4 CONFIGURATION OF THE EUT

The EUT was configured according to **ANSI C63.4 - 2001 & CISPR 22**. All I/O ports were connected to the appropriate peripherals. All peripherals and cables are listed below (including internal device) :

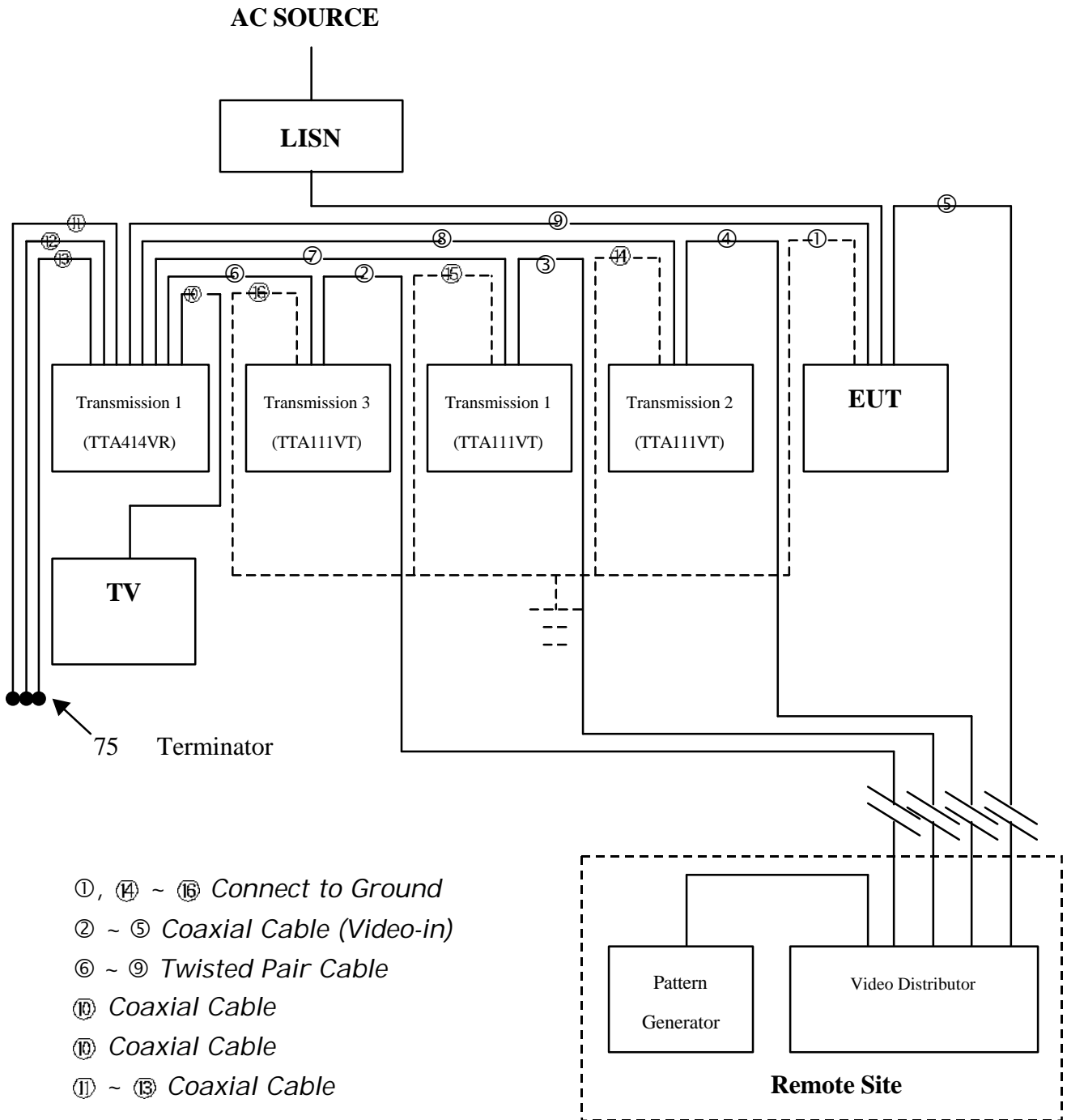

Figure 1



4.1 EUT

EUT Type : Proto Type Engineer Type Mass Production  
Condition when received : Good Damage : \_\_\_\_\_  
Device : Transmission  
Applicant : SMART CABLING & TRANSMISSION CORP.  
Manufacturer : SMART CABLING & TRANSMISSION CORP.  
Model Number : TTA111XXX  
Serial Number : N/A  
FCC ID : N/A  
Video-In : Metal Type Connector  
Video-Out : Plastics Type Connector  
Ground : Un-Shielded, 2.0 m, Metal Type Connector  
Power Cord (AC) : 2 pin  
Power Cord (DC) : Un-Shielded, 1.8 m, 2 pin  
Power Supply Type : Linear Adapter

4.2 PERIPHERALS

Transmission x 3

Manufacturer : SMART CABLING & TRANSMISSION CORP.  
Model Number : TTA111VT  
Serial Number : N/A  
FCC ID : N/A  
Data Cable : Shielded, 3.0 m, Connect to the Video-Out Port  
Power Cord : Un-Shielded, 1.8 m



Transmission

Manufacturer : SMART CABLING & TRANSMISSION CORP.  
Model Number : TTA414VR  
Serial Number : N/A  
FCC ID : N/A  
Data Cable : Shielded, 3.0 m, Connect to the Video-Out Port  
Power Cord : Un-Shielded, 1.8 m

TV

Manufacturer : TCL  
Model Number : 1419A  
Serial Number : N/A  
FCC ID : N/A  
Data Cable : Shielded, 1.8 m, Connected to the Video-In port  
Power Cord : Un-Shielded, 1.8 m

AC Adapter

Manufacturer : ELEC  
Model Number : YAD-1200500C  
Serial Number : N/A  
FCC ID : N/A  
Data Cable : N/A  
Power Cord : Un-Shielded, 1.8 m



Video Distributor (Remote Site)

Manufacturer : CS Lilin  
Model Number : PIH-6002  
Serial Number : N/A  
FCC ID : N/A  
Data Cable : Shielded, 10 m, Connected to the Video-In port  
Power Cord : Un-Shielded, 1.8 m

Pattern Generator (Remote Site)

Manufacturer : LEADER  
Model Number : 408  
Serial Number : 3037775  
FCC ID : N/A  
Data Cable : Shielded, 1.8 m  
Power Cord : Un-Shielded, 1.8 m

4.3 REMARK : N/A

## 5 EUT OPERATING CONDITION

- 5.1 The operation frequency of the EUT is 0~10 MHz.
- 5.2 Configure the EUT according to the **ANSI C63.4 - 2001 & CISPR 22**.
- 5.3 Turn on all power of EUT and peripheral.
- 5.4 Remote pattern generator send color bar signal to Video IN Port of Support Unit1(Video Distributor).
- 5.5 Video Output Port of Support Unit1(Video distributor) connected to Video Input Port of EUT via 10m Cable.
- 5.6 EUT' s Video Out Port Connected with the Support Unit2(Transmission TTA414VT) via 3m Cable.
- 5.7 Support Unit2(Transmission TTA414VT) connected with the Support Unit3(TV) via 1.8m cable and Support Unit3 (TV) display color signal.
- 5.8 Monitor the output signal of EUT during the test. (For EMS testing).
- 5.9 The photos of conducted test configuration, please refer to appendix A.**

## 6 LIMIT OF CONDUCTED POWER LINE EMISSION CLASS B

Frequency Range	Quasi Peak	Average
0.15 ~ 0.5 MHz	66 - 56 dBuV	56 - 46 dBuV
0.5 ~ 5 MHz	56 dBuV	46 dBuV
5 ~ 30 MHz	60 dBuV	50 dBuV

- 6.1 In the above table, the tighter limit applies at the band edges.

## 7 RESULT OF CONDUCTED POWER LINE TEST

- 7.1 The frequency range from 0.15 MHz to 30 MHz was investigated. All readings are quasi-peak values and average.
- 7.2 IF bandwidth : 9 kHz, Meas Time : 1 sec.
- 7.3 Temperature : 27 , Humidity : 60 % RH.
- 7.4 Deviations from the test standards and rules : None
- 7.5 The conducted test result were gained by following procedures :  
Level = Reading Level + Insertion Loss of LISN + Cable Loss  
(All calculation were done by ESHS30 EMI test receiver.)
- 7.6 Result : **PASSED**

### 8 CONDUCTED POWER LINE TEST DATA (PAGE 1)

HomeTek EMC LAB TEL :886-2-22608375

15 Dec 2004 10:39

#### CONDUCTED EMISSIONS

EUT: Transmission  
 Manuf: 3L026  
 Op Cond: LINE 1  
 Operator: VIC  
 Test Spec: FOR CISPR22 CLASS B  
 Comment: 110V/60-hz  
 TTA111VT  
 Result File: 302611b.dat : New Measurement

Prescan Measurement: Detectors: X PK / +AV  
 Meas Time: see scan settings  
 Subranges: 16  
 Acc Margin: 55 dB

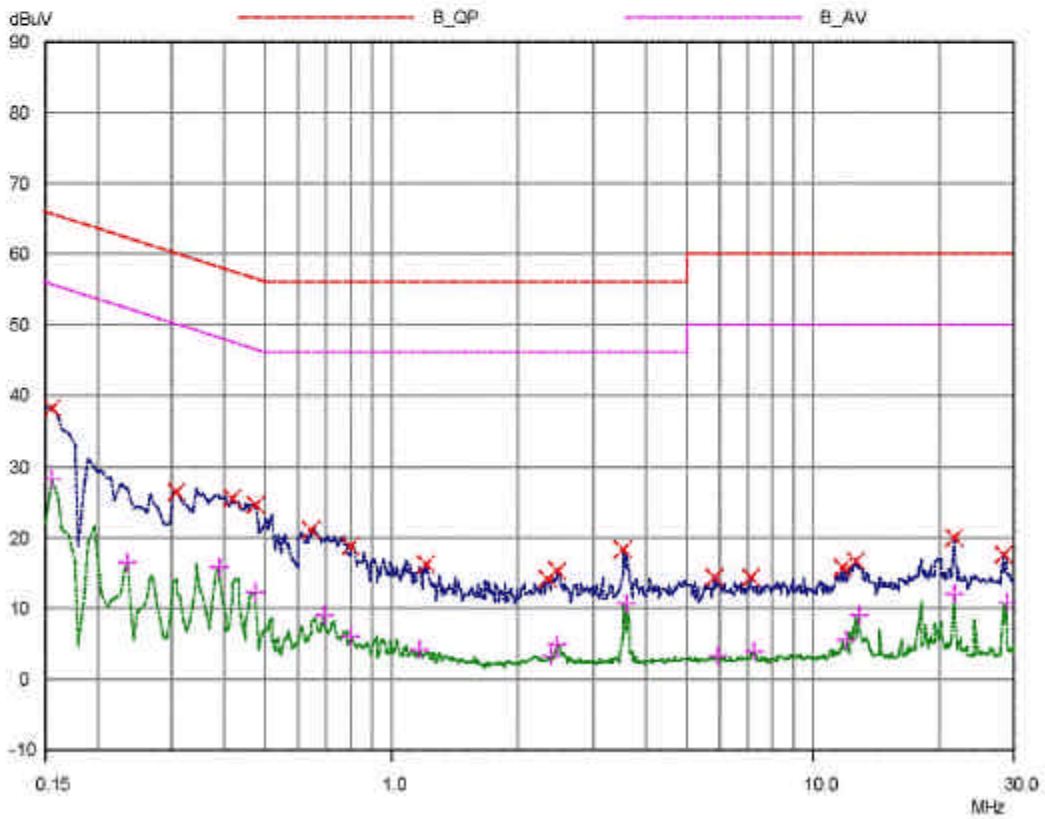



9 CONDUCTED POWER LINE TEST DATA (PAGE 2)

HomeTek EMC LAB TEL :886-2-22608375

16 Dec 2004 10:39

CONDUCTED EMISSIONS

EUT: Transmission  
 Manuf: 3L026  
 Op Cond: LINE 1  
 Operator: VIC  
 Test Spec: FOR CISPR22 CLASS B  
 Comment: 110V/60-hz  
 TTA111VT  
 Result File: 302611b.dat : New Measurement

Prescan Measurement: Detectors: X PK / +AV  
 Meas Time: see scan settings  
 Subranges: 16  
 Acc Margin: 55 dB

Peak Search Results

Frequency MHz	PK Level dBuV	PK Limit dBuV	PK Delta dB
0.155	38.19	65.73	27.54
0.31	26.36	59.97	33.61
0.415	25.40	67.55	32.15
0.475	24.53	66.43	31.90
0.645	21.15	56.00	34.85
0.8	18.72	66.00	37.28
1.21	16.15	56.00	39.85
2.35	14.22	66.00	41.78
2.47	15.32	56.00	40.68
3.55	18.40	66.00	37.60
5.8	14.38	60.00	45.62
7.08	14.28	60.00	45.72
11.61	15.83	60.00	44.17
12.48	16.69	60.00	43.31
21.43	19.89	60.00	40.11
28.0	17.51	60.00	42.49

Frequency MHz	AV Level dBuV	AV Limit dBuV	AV Delta dB
0.155	28.37	65.73	27.36
0.235	16.37	52.27	35.90
0.385	15.67	48.17	32.50
0.47	12.28	46.51	34.25
0.685	9.11	46.00	36.89
0.8	6.13	46.00	39.87
1.16	4.28	46.00	41.72
2.37	3.24	46.00	42.76
2.47	4.94	46.00	41.06
3.61	10.74	46.00	35.26
5.88	3.16	50.00	46.84
7.22	3.83	50.00	46.17
11.95	5.62	50.00	44.38
12.75	9.10	50.00	40.90
21.43	12.02	50.00	37.98
28.64	10.87	50.00	39.13

\* limit exceeded

10 CONDUCTED POWER LINE TEST DATA (PAGE 3)

HomeTek EMC LAB TEL :886-2-22608375

15 Dec 2004 10:22

CONDUCTED EMISSIONS

EUT: Transmission  
 Manuf: 3L026  
 Op Cond: LINE 2  
 Operator: VIC  
 Test Spec: FOR CISPR22 CLASS B  
 Comment: 110V/60-hz  
 TTA111VT  
 Result File: 302621b.dat : New Measurement

Prescan Measurement: Detectors: X PK / +AV  
 Meas Time: see scan settings  
 Subranges: 16  
 Acc Margin: 55 dB

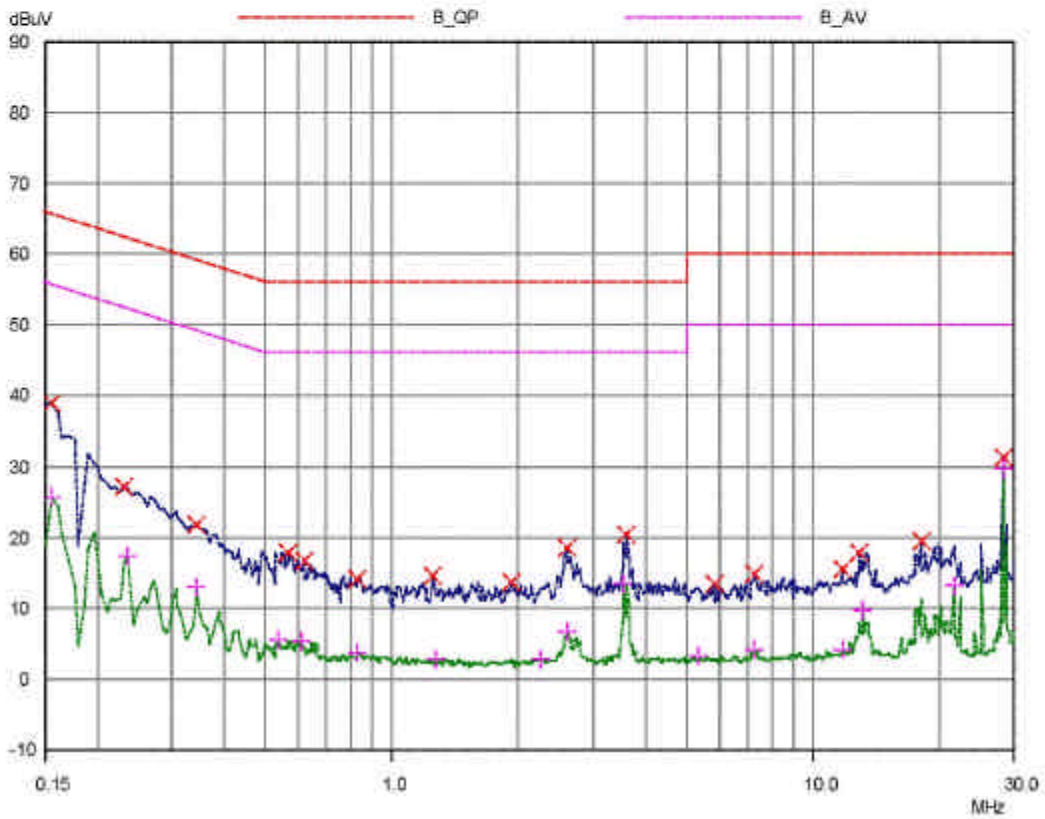



11 CONDUCTED POWER LINE TEST DATA (PAGE 4)

HomeTek EMC LAB TEL :886-2-22608375

16 Dec 2004 10:22

CONDUCTED EMISSIONS

EUT: Transmission  
 Manuf: 3L026  
 Op Cond: LINE 2  
 Operator: VIC  
 Test Spec: FOR CISPR22 CLASS B  
 Comment: 110V/50-hz  
 TTA111VT  
 Result File: 302621b.dat : New Measurement

Prescan Measurement: Detectors: X PK / +AV  
 Meas Time: see scan settings  
 Subranges: 16  
 Acc Margin: 55 dB

Peak Search Results

Frequency MHz	PK Level dBuV	PK Limit dBuV	PK Delta dB
0.155	38.81	65.73	26.92
0.23	27.17	62.45	35.28
0.345	21.80	59.08	37.28
0.57	17.92	56.00	38.08
0.615	16.68	56.00	39.32
0.83	14.11	56.00	41.89
1.25	14.59	56.00	41.41
1.91	13.78	56.00	42.22
2.58	18.53	56.00	37.47
3.61	20.39	56.00	35.61
5.79	13.38	60.00	46.62
7.26	14.90	60.00	45.10
11.61	15.48	60.00	44.52
12.82	17.87	60.00	42.13
17.93	19.40	60.00	40.60
28.0	31.37	60.00	28.63

Frequency MHz	AV Level dBuV	AV Limit dBuV	AV Delta dB
0.155	25.68	55.73	30.05
0.235	17.27	52.27	35.00
0.345	13.01	49.08	36.07
0.535	5.49	46.00	40.51
0.605	5.30	46.00	40.70
0.83	3.67	46.00	42.33
1.26	2.77	46.00	43.23
2.23	2.89	46.00	43.11
2.61	6.73	46.00	39.27
3.55	13.46	46.00	32.54
5.35	3.26	50.00	46.74
7.22	4.26	50.00	45.74
11.61	4.16	50.00	45.84
13.07	9.84	50.00	40.16
21.48	13.24	50.00	36.76
28.0	29.78	50.00	20.24

\* limit exceeded

## RADIATED EMISSION TEST

### 1 TEST INSTRUMENTS & FACILITIES

The following test Instruments was used during the radiated emission test :

Item	Instruments /facilities	Specification	Manufacturer	Model # / S/N#	Date of Cal.
1	OPEN AREA TEST SITE	<input checked="" type="checkbox"/> OATS 3			JUL/2004
2	EMI TEST RECEIVER	20Hz ~ 26.5GHz	ROHDE & SCHWARZ	ESMI 845442/006	JAN/2004
3	PRE-AMPLIFIER	9KHz ~ 3000MHz	ADVANTEST	BB525C 90081001	SEP/2004
4	ANTENNA (BI-LOG)	25MHz ~ 2GHz	SCHAFFNER	CBL6112B S/N : 2614	MAY/2004
5	Attenuation	50 /6dB	JYE BAO	FAT-N (M-F) 001	JUL/2004
6	Cable	10m	SUHNER	RG214/U OS3-003	DEC/2004
7	Cable	14m	BELDEN	9913 OS3-001	DEC/2004
8	EMI 32 (software)	N/A	AUDIX	19991013-0923	N/A

Note : Items 1 ~ 7 were calibrated within period of 1 year.

## 2 TEST PROCEDURE

- 2.1 The EUT was test according to **ANSI C63.4 - 2001 & CISPR 22**.
- 2.2 The radiated test was performed at HomeTek Lab' s Open Site **III**.
- 2.3 The frequency range from **30** MHz to **1** GHz, the measurement were made at **10** meters, with a BI-log antenna.

## 3 TEST SETUP

### 3.1 TEST SETUP OF OPEN SITE.

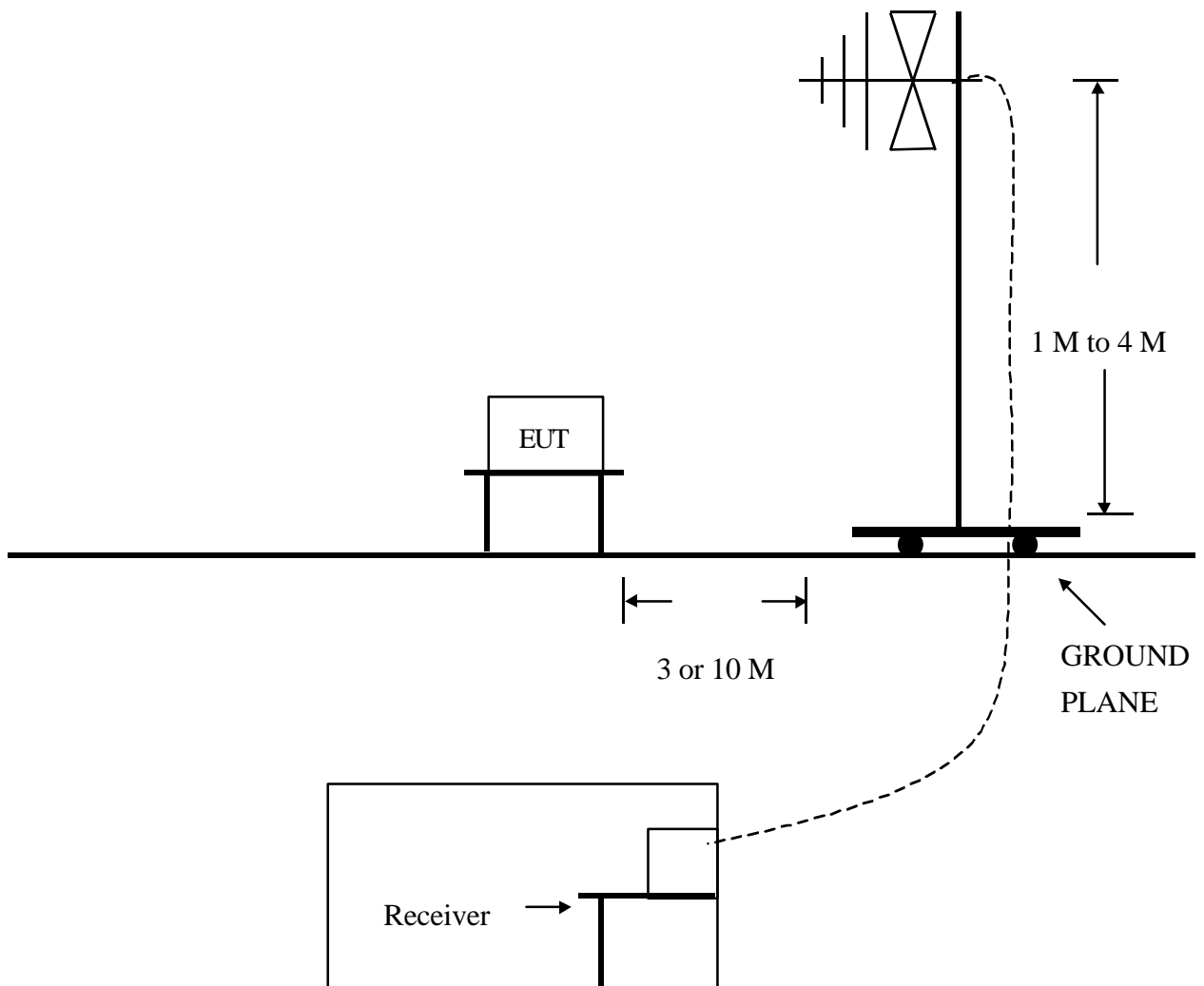

### 3.2 TEST SETUP OF EUT

ELECTRICAL AND ELECTRONIC EQUIPMENT IN THE RANGE OF 9kHz TO 40 GHz

ANSI  
C63.4-2001

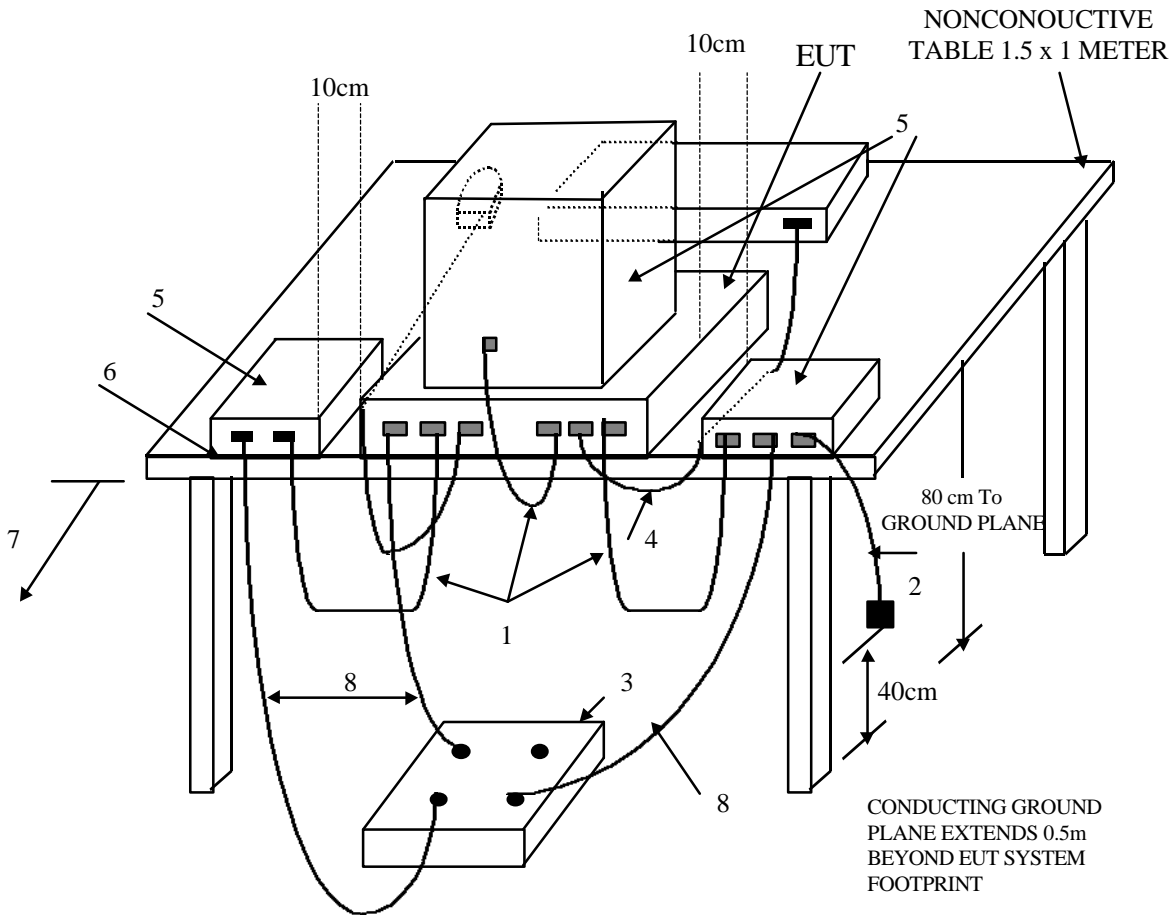

(Details for setup configuration, please refer to appendix A.)

**LEGEND:**

1. Interconnecting cables that hang closer than 40 cm to the ground plane shall be folded back and forth forming a bundle 30 to 40 cm long, hanging approximately in the middle between ground plane and table.
2. I/O cables that are connected to a peripheral shall be bundled in center. The end of the cable may be terminated if required using correct terminating impedance. The total length shall not exceed 1m.
3. If LISNs are kept in the test setup for radiated emissions, it is preferred that they be installed under the ground plane with the receptacle flush with the ground plane.
4. Cables of hand-operated devices, such as keyboards, mice, etc., have to be placed as close as possible to the controller.
5. Non-EUT components of EUT system being tested.
6. The rear of all components of the system under test shall be located flush with the rear of the table.
7. No vertical conducting wall used.
8. Power cords drape to the floor and are routed over to receptacle.

**Test Configuration**

**Tabletop Equipment Radiated Emission**

4 CONFIGURATION OF THE EUT

Same as “Conducted Power Line test”, section 4

5 EUT OPERATING CONDITION

5.1 Same as “Conducted Power Line test”, section 5

5.2 The radiated emission in the frequency range from 30 MHz - 1000 MHz was test in a horizontal and vertical polarization at HomeTek Lab’ s open site III.

**5.3 The photos of radiated test configuration, please refer to appendix A.**

6 LIMIT OF RADIATED EMISSION CLASS B

CISPR 22

Frequency (MHz)	Measurement Distance	Limit (dBuV/m)
30 - 230	10 (M)	30
230 - 1000	10 (M)	37

6.1 The tighter limit shall apply at the edge between two frequency bands.

6.2 Measurement distance in meters between the measuring instrument antenna and the closed point of any part of the EUT or peripherals.



## 7 RESULT OF RADIATED EMISSION TEST

- 7.1 The frequency range from 30 MHz to 1 GHz was investigated.
- 7.2 All readings below or equal 1 GHz are quasi-peak or peak values with resolution bandwidth of 120 KHz.
- 7.3 All readings above 1 GHz are average or peak values with resolution bandwidth of 1 MHz
- 7.4 The measurements were made at 10 meters of HomeTek Lab's open site III.
- 7.5 Temperature : 33 , Humidity : 55 % RH.
- 7.6 Deviation form the test standards and rules : None
- 7.7 The radiation emission result were gained by the following method :  
Level = Reading Level + Probe Factor (Antenna Factor) + Cable Loss – Preamp Factor  
Over Limit = Level – Limit Line
- 7.8 The radiated mission test was passed at minimum margin :  
Vertical 60.30 MHz/ 26.51 dBuV/m, Antenna Height 1.1 Meter,  
Turn Table 138 degree, Model : TTA111VT.
- 7.9 Result : **PASSED**



HomeTek Technology Inc.

No. 67-9, Shi-Men Rd., Tu-Chen City,  
Taipei County, Taiwan R.O.C.  
Tel: 02-22608375  
Fax: 02-22748013

Data#: 3 File#: 31026.emi

Date: 2004-12-15 Time: 16:58:28

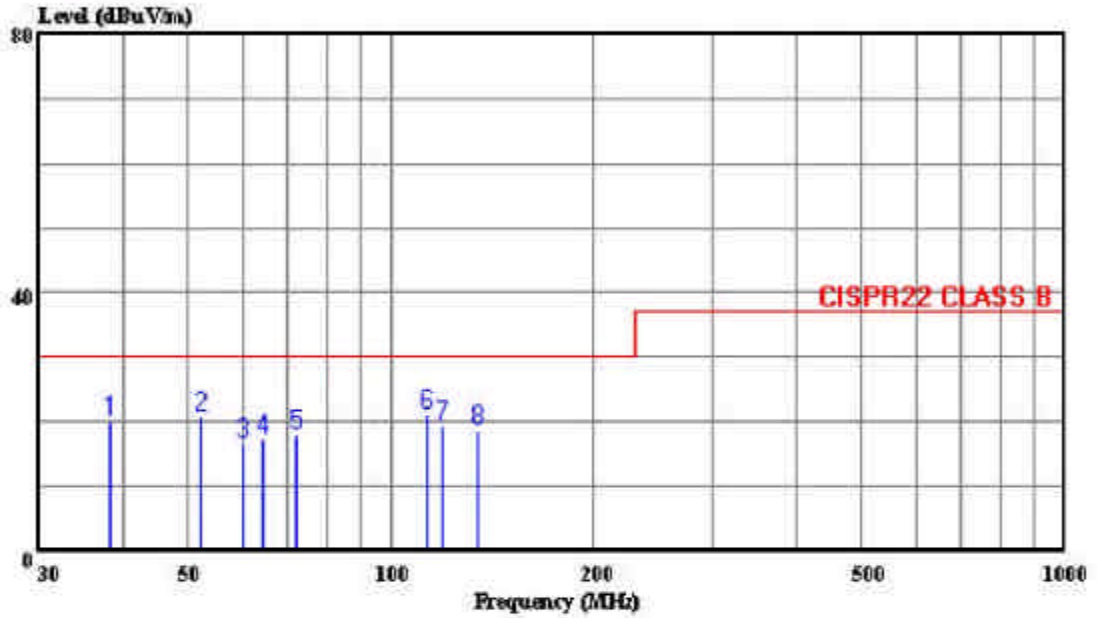

Traces:

Ref Trace:

Condition: CISPR22 CLASS B 10m CHASE 2614 052604 HORIZONTAL

cut : Transmission

power: 110V/60Hz

memo : TTA111VT

Page: 1

Freq	Level	Limit	Over	ReadAntenna	Cable	Preamp		
MHz	dBuV/m	dBuV/m	dB	Level	Factor	Loss	Factor	Remark
				dBuV	dB/m	dB	dB	
1	38.273	20.04	30.00	-9.96	35.82	13.17	0.94	29.89 Peak
2	52.260	20.69	30.00	-9.31	42.40	7.01	1.12	29.83 Peak
3	60.307	16.74	30.00	-13.26	39.58	5.68	1.17	29.70 Peak
4	64.253	17.17	30.00	-12.83	39.96	5.64	1.20	29.64 Peak
5	72.493	18.06	30.00	-11.92	40.27	6.04	1.27	29.50 Peak
6	112.507	21.14	30.00	-8.86	37.17	11.53	1.53	29.11 Peak
7	118.800	19.41	30.00	-10.59	35.32	11.68	1.56	29.15 Peak
8	134.220	18.78	30.00	-11.22	35.34	11.04	1.64	29.24 Peak



HomeTek Technology Inc.

No. 67-9, Shi-Men Rd., Tu-Chen City,  
 Taipei County, Taiwan R.O.C.  
 Tel: 02-22608375  
 Fax: 02-22748013

Data#: 4 File#: 31026.emi

Date: 2004-12-15 Time: 17:20:49

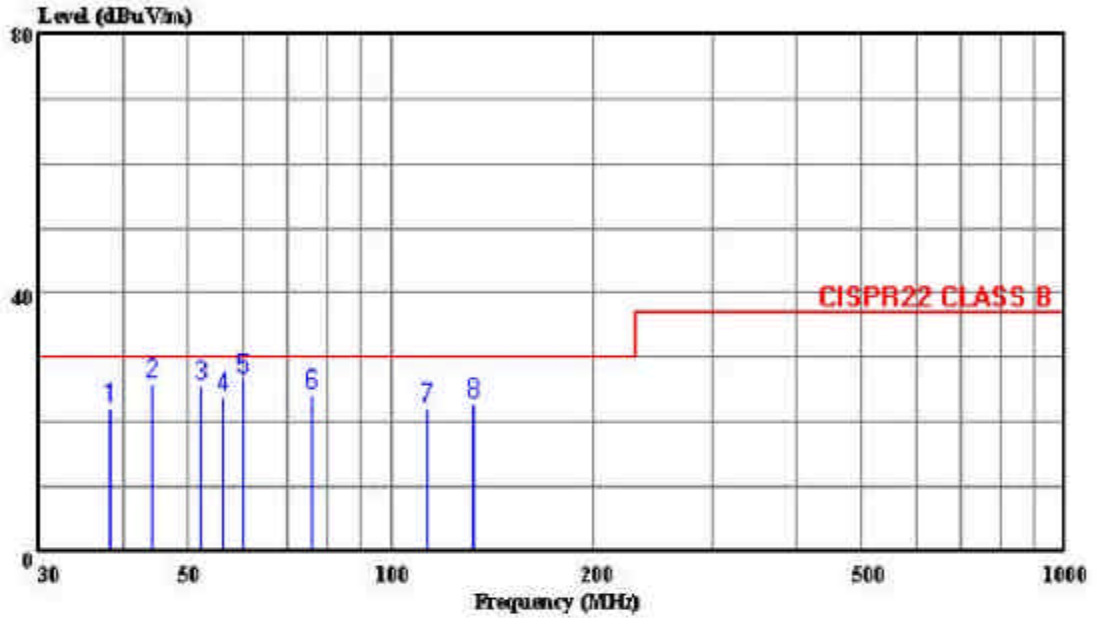

Trace:

Ref Trace:

Condition: CISPR22 CLASS B 10m CHASE 2614 052604 VERTICAL  
 out : Transmission  
 power: 110V/60Hz  
 memo : PTA111VT

Page: 1

	Freq	Level	Limit	Over	Read	Antenna	Cable	Preamp	Remark
	MHz	dBuV/m	dBuV/m	dB	dBuV	dB/m	dB	dB	
1	38.244	22.33	30.00	-7.67	38.11	13.17	0.94	29.89	Peak
2	44.311	26.08	30.00	-3.92	44.85	10.89	1.03	29.89	Peak
3	52.262	25.72	30.00	-4.28	47.43	7.01	1.12	29.83	Peak
4	56.289	23.77	30.00	-6.23	46.18	6.21	1.14	29.77	Peak
5	60.304	26.51	30.00	-3.49	49.35	5.68	1.17	29.70	Peak
6	76.420	24.37	30.00	-5.63	46.03	6.48	1.29	29.43	Peak
7	112.538	22.20	30.00	-7.80	38.23	11.55	1.55	29.11	Peak
8	132.631	22.95	30.00	-7.05	39.39	11.16	1.63	29.23	Peak



## **SAMPLE OF FCC LABEL**

This device complies with part 15 of the FCC Rules.  
Operation is subject to the following two conditions: (1)  
This device may not cause harmful interference. And (2)  
this device must accept any interference received, including  
interference that may cause undesired operation.



HomeTek Technology Inc.

## **Appendix A**

# **PHOTOS OF TEST CONFIGURATION**



HomeTek Technology Inc.

## PHOTO OF CONDUCTED POWER LINE TEST

Model : TTA111 VT



Front View



Rear View

## PHOTO OF RADIATED EMISSION TEST

Model : TTA111VT

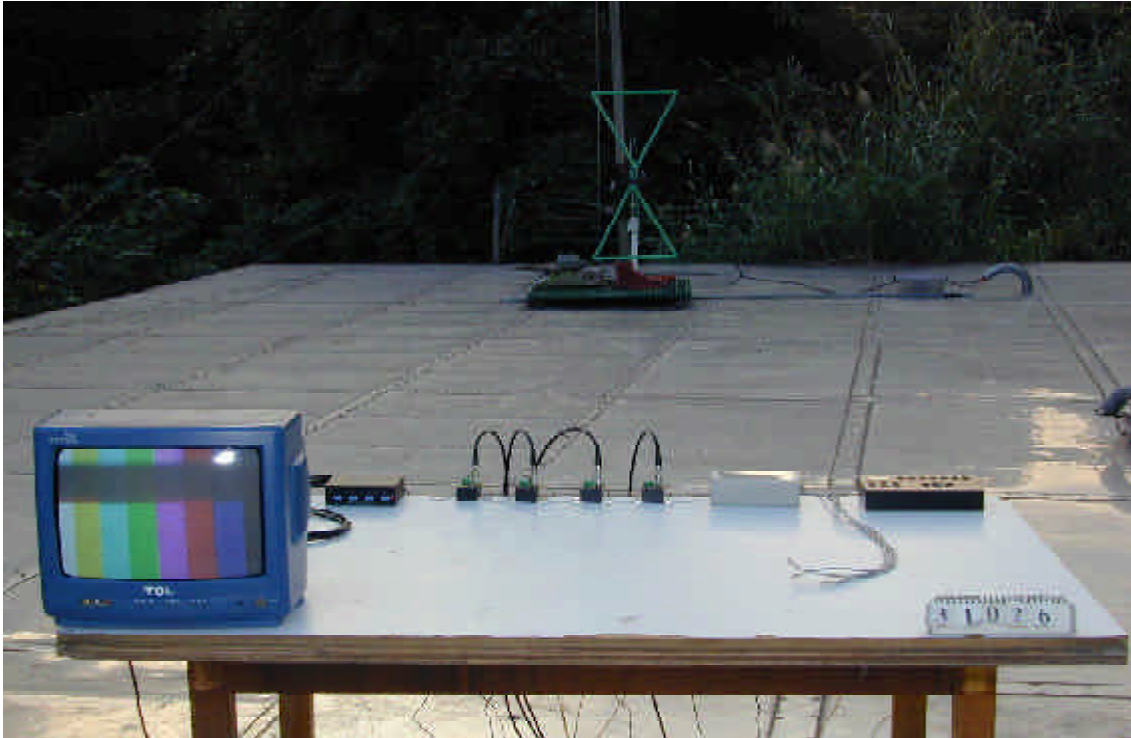

Front View

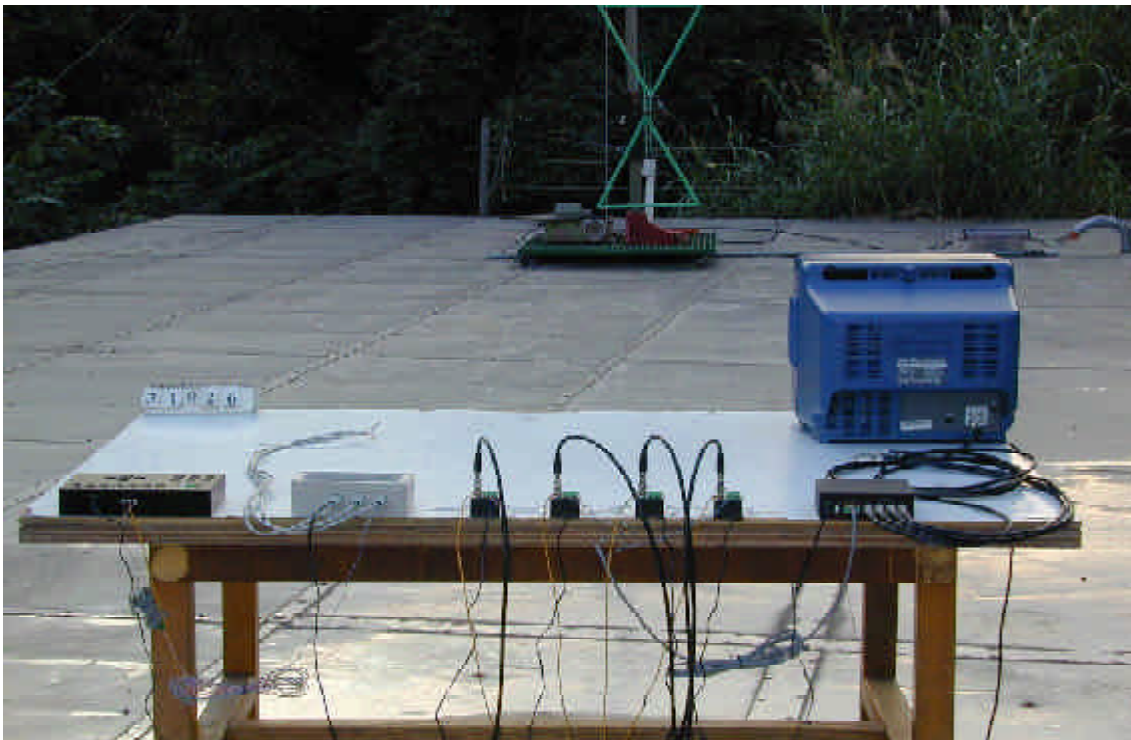

Rear View



HomeTek Technology Inc.

**Appendix B**  
**PHOTOS OF EUT**

### PHOTO OF EUT

Model : TTA111VT



Front View of EUT



Rear View of EUT

### PHOTO OF EUT

Model : TTA111VT

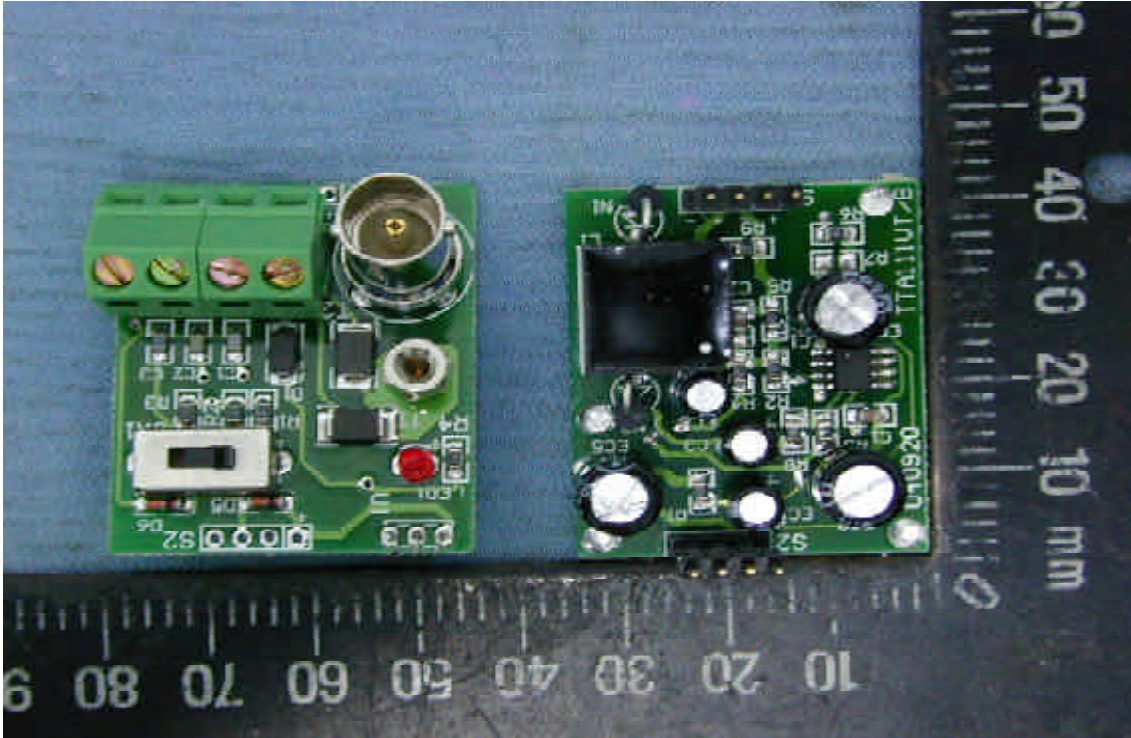

Component Side of Main Board

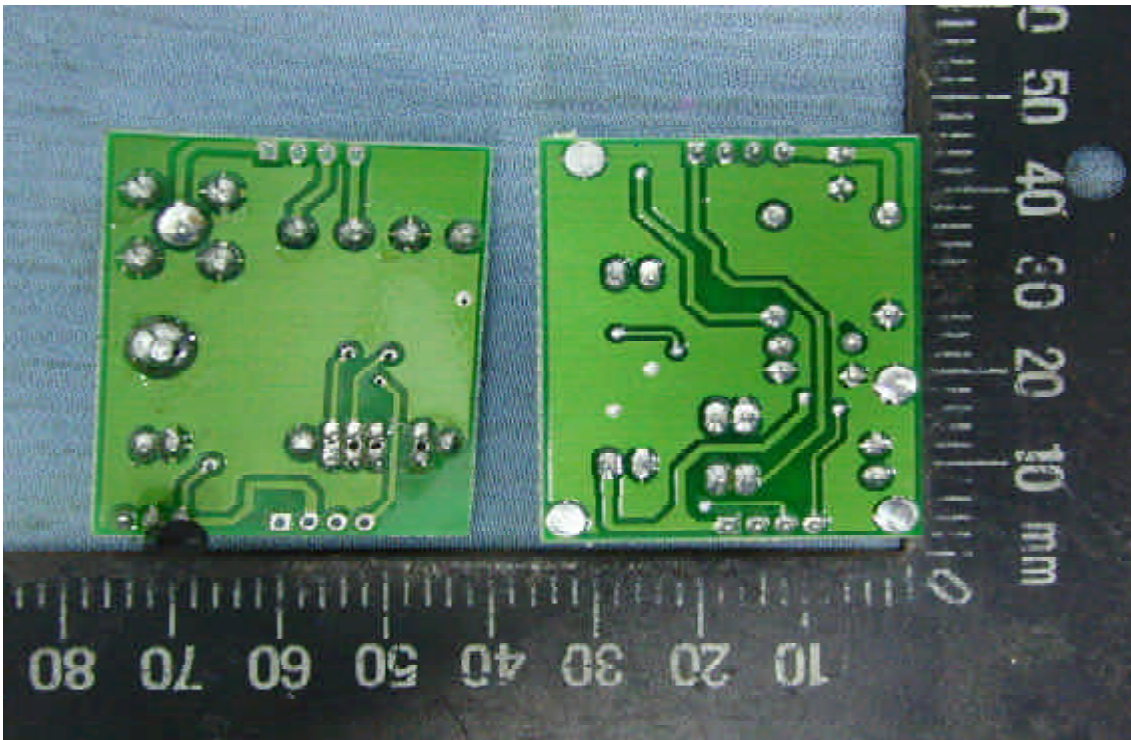

Solder Side of Main Board



**PHOTO OF EUT**

Model : TTA111XXX



Front View of Adaptor



Rear View of Adaptor



HomeTek Technology Inc.

## PHOTO OF EUT

Model : TTA111VT



Full View of I/O Port

United States Department of Commerce  
National Institute of Standards and Technology

**NVLAP**®

ISO/IEC 17025:1999  
ISO 9002:1994

**Certificate of Accreditation**



**HOMETEK TECHNOLOGY INC.**

TAIPEI SHIEN 236  
TAIWAN

*is recognized by the National Voluntary Laboratory Accreditation Program  
for satisfactory compliance with criteria set forth in NIST Handbook 150:2001,  
all requirements of ISO/IEC 17025:1999, and relevant requirements of ISO 9002:1994.  
Accreditation is awarded for specific services, listed on the Scope of Accreditation, for:*

**ELECTROMAGNETIC COMPATIBILITY AND TELECOMMUNICATIONS**

September 30, 2005

*Effective through*

A handwritten signature in black ink, appearing to read "Stephen P. Madl".

*For the National Institute of Standards and Technology*  
NVLAP Lab Code: 200331-0

## Scope of Accreditation



### ELECTROMAGNETIC COMPATIBILITY AND TELECOMMUNICATIONS

NVLAP LAB CODE 200331-0

#### HOMETEK TECHNOLOGY INC.

P.O Box: 13-131, Pan-Chiao City  
No. 67-9 Shir Men Rd., Tu Chen City  
Taipei Shien 236  
TAIWAN

Mr. Grant Huang

Phone: 886-2-22608375 Fax: 886-2-22748013

E-Mail: hometek@ms15.hinet.net

#### *NVLAP Code Designation / Description*

#### **Emissions Test Methods:**

- |           |                                                                                                                                                                                                |
|-----------|------------------------------------------------------------------------------------------------------------------------------------------------------------------------------------------------|
| 12/CIS22  | IEC/CISPR 22 (1997) & EN 55022 (1998) + A1(2000): Limits and methods of measurement of radio disturbance characteristics of information technology equipment                                   |
| 12/CIS22a | IEC/CISPR 22 (1993) and EN 55022 (1994): Limits and methods of measurement of radio disturbance characteristics of information technology equipment, Amendment 1 (1995) and Amendment 2 (1996) |
| 12/CIS22b | CNS 13438 (1997): Limits and Methods of Measurement of Radio Interference Characteristics of Information Technology Equipment                                                                  |
| 12/FCC15b | ANSI C63.4 (2001) with FCC Method 47 CFR Part 15, Subpart B: Unintentional Radiators                                                                                                           |

September 30, 2005

Effective through

For the National Institute of Standards and Technology

National Institute  
of Standards and Technology



National Voluntary  
Laboratory Accreditation Program

ISO/IEC 17025:1999  
ISO 9002:1994

## Scope of Accreditation



Page: 2 of 2

**ELECTROMAGNETIC COMPATIBILITY  
AND TELECOMMUNICATIONS**

**NVLAP LAB CODE 200331-0**

**HOMETEK TECHNOLOGY INC.**

*NVLAP Code    Designation / Description*

12/T51      AS/NZS CISPR 22 (2002) and AS/NZS 3548 (1997): Electromagnetic Interference -  
Limits and Methods of Measurement of Information Technology Equipment

September 30, 2005

*Effective through*

A handwritten signature in black ink, appearing to read 'William R. Miel'.

*For the National Institute of Standards and Technology*