



# CE TEST REPORT

FOR

TWISTED PAIR TRANSMISSION SYSTEM

Model: TTP111VP-LK

Issued to

Smart Cabling & Transmission Corp.

10F, No. 493, Chung-Cheng Rd., Hsin Tien Dist., New Taipei City 231, Taiwan, R.O.C.

Issued by

PEP Testing Laboratory

<b>EMC Test Site</b>	<b>Xizhi Office and Lab</b>	<b>12F.-3, No.27-1, Ln. 169, Kangning St., Xizhi Dist., New Taipei City 221, Taiwan (R.O.C.)</b>
--------------------------	---------------------------------	--

*Note: This test refers exclusively to the test presented test model and sample. This report shall not be reproduced except in full, without the written approval of PEP Testing Laboratory. This document may be altered or revised by PEP Testing Laboratory. Personnel only, and shall be noted in the revision section of the document.*



<b>TABLE OF CONTENTS</b> -----	<b>2</b>
<b>1. GENERAL INFORMATION</b> -----	<b>4</b>
IEC 61000-4-5: 2005-----	4
1.1 DESCRIPTION OF THE TESTED SAMPLES -----	5
1.3TEST METHODOLOGY-----	6
1.4 DESCRIPTION OF THE SUPPORT EQUIPMENTS-----	7
1.5 FEATURES OF EUT: PLEASE REFER TO USER MANUAL OR PRODUCT SPECIFICATION. -----	7
<b>2. INSTRUMENT AND CALIBRATION</b> -----	<b>8</b>
2.1 MEASURING INSTRUMENT CALIBRATION-----	8
2.2 TEST AND MEASUREMENT EQUIPMENT-----	8
2.3 TEST PERFORMED-----	10
2.4 APPENDIX-----	11
<b>3. CONDUCTED EMISSION MEASUREMENT</b> -----	<b>13</b>
3.1 TEST SET-UP-----	13
3.2 LIMIT-----	13
3.3 TEST PROCEDURE-----	13
3.4 TEST SPECIFICATION-----	14
3.5 RESULT: PASSED-----	14
3.6 TEST DATA:-----	14
PLEASE REFER TO APPENDIX 2-----	14
<b>4. RADIATED EMISSION MEASUREMENT</b> -----	<b>15</b>
4.1 TEST SETUP-----	15
4.2 LIMIT-----	16
4.3 TEST PROCEDURE-----	16
4.4 TEST SPECIFICATION-----	16
4.5 RESULT: PASSED-----	17
4.6 TEST DATA:-----	17
PLEASE REFER TO APPENDIX 2-----	17
<b>5. POWER HARMONIC MEASUREMENT</b> -----	<b>18</b>
5.1 TEST SETUP-----	18
5.2 LIMIT OF HARMONIC CURRENT-----	18
5.3 TEST PROCEDURE-----	18
5.4 TEST SPECIFICATION-----	18
5.5 RESULT: PASSED-----	19
5.6 TEST DATA:-----	19
PLEASE REFER TO APPENDIX 2-----	19
<b>6. VOLTAGE FLUCTUATIONS</b> -----	<b>20</b>
6.1 TEST SETUP-----	20
6.2 VOLTAGE FLUCTUATIONS TEST-----	20
6.3 TEST PROCEDURE-----	20
6.4 TEST SPECIFICATION-----	20
6.5 RESULT: PASSED-----	20
6.6 TEST DATA:-----	20
PLEASE REFER TO APPENDIX 2-----	20
<b>7. ELECTROSTATIC DISCHARGE IMMUNITY TEST (ESD)</b> -----	<b>21</b>
7.1 TEST PROCEDURE-----	21
7.2 TEST SETUP-----	21
7.3 TEST LEVEL-----	21
7.4 TEST RESULT.-----	22



<b>8.</b>	<b>RADIATED SUSCEPTIBILITY MEASUREMENT (RS)</b>	<b>23</b>
8.1	TEST SETUP	23
8.2	TEST PROCEDURE	23
8.3	TEST LEVEL	23
8.4	TEST PROCEDURE	24
8.5	TEST RESULT	24
<b>9.</b>	<b>ELECTRICAL FAST TRANSIENT/BURST (EFT)</b>	<b>25</b>
9.1	TEST SETUP	25
9.2	TEST PROCEDURE	25
9.3	TEST PROCEDURE	25
9.4	TEST LEVEL	26
9.5	TEST RESULT:	26
<b>10.</b>	<b>SURGE</b>	<b>27</b>
10.1	TEST SETUP	27
10.2	TEST PROCEDURE	27
10.3	TEST LEVEL	27
10.4	TEST PROCEDURE	28
10.5	TEST RESULT:	28
<b>11.</b>	<b>IMMUNITY TEST TO CS CONDUCTED DISTURBANCE (CS)</b>	<b>29</b>
11.1	TEST SETUP	29
11.2	TEST PROCEDURE	29
11.3	TEST LEVEL	29
11.4	TEST PROCEDURE	30
11.5	TEST RESULT:	30
<b>12.</b>	<b>POWER FREQUENCY MAGNETIC FIELD (MAGNETIC)</b>	<b>31</b>
12.1	TEST SETUP	31
12.2	TEST STANDARD	31
12.3	TEST LEVEL	31
12.4	TEST PROCEDURE	31
12.5	TEST RESULT	32
<b>13.</b>	<b>VOLTAGE DIPS AND INTERRUPTION MEASUREMENT</b>	<b>33</b>
13.1	TEST SETUP	33
13.2	TEST PROCEDURE	33
13.3	TEST LEVEL	34
13.4	TEST PROCEDURE	34
13.5	TEST RESULT:	35
<b>14.</b>	<b>PERFORMANCE CRITERIA</b>	<b>36</b>
<b>15.</b>	<b>MEASUREMENT UNCERTAINTY</b>	<b>37</b>

**APPENDIX 1**

**PHOTOS OF TEST CONFIGURATION**

**APPENDIX 2**

**TEST DATA**

**PHOTOS OF EUT**



**1. GENERAL INFORMATION**

**Applicant** : Smart Cabling & Transmission Corp.  
**Address** : 10F, No. 493, Chung-Cheng Rd., Hsin Tien Dist., New Taipei City 231, Taiwan, R.O.C.  
**Manufacturer** : Smart Cabling & Transmission Corp.  
**Address** : 10F, No. 493, Chung-Cheng Rd., Hsin Tien Dist., New Taipei City 231, Taiwan, R.O.C.  
**EUT** : TWISTED PAIR TRANSMISSION SYSTEM  
**Model Name** : TTP111VP-LK  
**Model Differences** : N/A

**Measurement procedure used:**

**EMI :**

AS/NZS CISPR 22: 2009

EN55022 CLASS B: 2010

EN61000-3-2:2006+A1:2009+A2:2009

EN 61000-3-3:2008

**EMS:**

AS/NZS CISPR 24: 2009

EN55024: 2010

IEC 61000-4-2 : 2008

IEC 61000-4-3 : 2006+A1: 2007+A2:2010

IEC 61000-4-4 : 2004+A1:2010

IEC 61000-4-5: 2005

IEC 61000-4-6: 2008

IEC 61000-4-8: 2009

IEC 61000-4-11: 2004

**Deviation from Applicable Standard**

**According to the applicant's declaration this EUT is a class B product**

The above equipment was tested by PEP Testing Laboratory for compliance with EMC requirements set forth in the EUROPEAN COUNCIL DIRECTIVE 2004/108/EC and the technical standards mentioned above. The results of testing in this report apply only to the product/system, which was tested. Other similar equipment will not necessarily produce the same results due to production tolerance.

This test report shall not be reproducing in part without written approval of PEP Testing Laboratory

**Tested By:**

**Reviewed by:**

*S.k Chang*

*Alex Chou*

MAY 30, 2012

MAY 30, 2012

**Date**

S.K. Chang/ Engineer

**Date**

Alex Chou / Manager



**1.1 DESCRIPTION OF THE TESTED SAMPLES**

EUT Type :  Engineer Type

Condition when received :  Good  Damage :

EUT Name : TWISTED PAIR TRANSMISSION SYSTEM

Model Number : TTP111VP-LK

Receipt Date : 05/17/2012

EUT Power Rating :  AC Power  
 DC Power  
 DCV from PC  
 DCV from Adaptor

AC Power Adaptor Rating : Input 100-240Vac, 50/60Hz, 0.2A  
Output 12Vdc, 0.5A

AC Power Cord Type : 0.8 m  Un-Shielded  Shielded

**1.2 I/O PORT OF THE EUT**

I/O port type	Q'ty	Tested with
RJ45 Port	2	2
BNC Port	2	2



### **1.3TEST METHODOLOGY**

#### **EUT SYSTEM OPERATION**

1. The EUT was configured according to EN55022 CLASS B.
2. Photos of test configuration please refer to appendix 1.
3. Perform the EMC testing procedures, and measure the maximum emission noise.



## 1.4 DESCRIPTION OF THE SUPPORT EQUIPMENTS

### Setup Diagram

See test photographs attached in appendix 1 for the actual connections between EUT and support equipment.

### Support Equipment

Peripherals Devices:

OUTSIDE SUPPORT EQUIPMENT							
No.	Equipment	Model	Serial No.	FCC ID/ BSMI ID	Trade name	Data Cable	Power Cord
1.	CCD	N/A	N/A	N/A	N/A	N/A	N/A
2.	MONITOR	2212Ph	E9777JA00 166	R33037	AOC	Shielded 1.8m	Unshielded 1.8m
EUT							
No.	Equipment	Model	Serial No.	FCC ID/ BSMI ID	Trade name	Data Cable	Power Cord
1.	Adaptor	DSC-6PFA-1 2 FEU 120050	N/A	N/A	DVE	N/A	Unshielded 0.8m

**Note:** All the above equipment /cable were placed in worse case position to maximize emission signals during emission test.

**Grounding:** Grounding was in accordance with the manufacturer's requirement and conditions for the intended use.

## 1.5 FEATURES OF EUT: PLEASE REFER TO USER MANUAL OR PRODUCT SPECIFICATION.



## 2. INSTRUMENT AND CALIBRATION

### 2.1 MEASURING INSTRUMENT CALIBRATION

The measuring equipment utilized to perform the tests documented in the report has been calibrated once a year or in accordance with the manufacturer's recommendations, and is traceable to recognized national standards.

### 2.2 TEST AND MEASUREMENT EQUIPMENT

The following list contains measurement equipment used for testing. The equipment conforms to the requirement of CISPR 16-1, ANSI C63.2 and. Other required standards.

Calibration of all test and measurement, including any accessories that may effect such calibration, is checked frequently to ensure the accuracy. Adjustments are made and correction factors are applied in accordance with the instructions contained in the respective.

**TABLE LIST OF TEST AND MEASUREMENT EQUIPMENT**

Conducted Emission Measurement					
Instrument	Manufacturer	Model No.	Serial No.	Calibration Due Date	Note
RF Cable	MIYAZAKI&ANRITSU	RG 58A&MP59B	M79094	Apr. 08, 2013	
LISN	Rolf Heine Hochfrequenztechnik	NNB-2/16z	98062	Jan. 16, 2013	
Spectrum Analyzer	ADVANTEST	R3261C	87120343	Mar. 28, 2013	
EMI Test Receiver	R&S	EAHS-10	1093.4495.03	Mar. 21, 2013	
Radiated Emission Measurement					
Instrument	Manufacturer	Model No.	Serial No.	Calibration Due Date	Note
EMC Test Receiver	LIG NEx1	ER-265	L0907B006	7-Nov-12	
Bilog Antenna	SUNOL	JB1	A052204	27-Jun-12	
Turn table	EMCO	2080	9508-1805	N/A	
Controller	EMCO	2090	9804-1328	N/A	
Preamplifier	WIRELESS	FPA6592G	60017	11-Aug-12	
RF Cable	JYE BAO	RG214/U	25M-002	1-Nov-12	
Thermo-Hygro meter	WISEWIND	4-INU-1	50100378	2-Nov-12	
Double Ridged Guide HORN ANTENNA	SCHWADZBECK	BBHA9120D	491	31-Oct-12	



Microwave Preamplifier	SCHWADZBECK	BBV 9718	9718-008	7-Nov-12	
Microflex Cable	HUBER SUHNER	SUCOFLEX 104	302339/4	7-Nov-12	
Microflex Cable	HUBER SUHNER	SUCOFLEX 104	N/A	7-Nov-12	
Power Harmonic Measurement and Voltage Fluctuations					
Instrument	Manufacturer	Model No.	Serial No.	Calibration Due Date	Note
5KV AC Power Source	SCHAFFNER	NSG1007	55869	24-Jun-12	
Signal	SCHAFFNER	CCN1000-1	72281	24-Jun-12	
Conditioning					
EMS					
Instrument	Manufacturer	Model No.	Serial No.	Calibration Due Date	Note
EN61000-4-2					
ESD Generator	Noiseken	ESS-2002	N/A	Mar.18,2013	
EN61000-4-3					
Power Meter	BOONTON	4231A	110602	15-May-13	
Signal Generator	R&S	SM300	101722	22-Jun-12	
Electric Field probe	ETS-LINDGREN	HI-6005	29837	N/A	
Power Amplifier	SCHAFFNER	CBA9413B	4039	N/A	
Power Amplifier	TESEQ	CBA3G-050	T43752	N/A	
SWITCH NETWORK	TESEQ	RFB2000	26336	N/A	
EN61000-4-4/ EN61000-4-5/ IEC61000-4-8/ EN61000-4-11					
EMC Immunity Test system	EMC PARTNERAG	TRA200IN6	739	22-Jun-12	
Conducted disturbances generator	FRANKONIA	CIT10/75	102D3233	29-Aug-12	
CDN	SCHAFFNER	CDN M316	20653	11-Aug-12	
CDN	SCHAFFNER	CDN M316	19286	11-Aug-12	
CDN	FRANKONIA	RJ45	60050134	26-Jun-12	
6dBAttenuator	FRANKONIA	75-A-FFN-06	102D3233	N/A	
Induction Coil Interface	SCHAFFNER	2141	6019	N/A	



---

EM Injection Clamp	FCC	F-203I-23MM	471	24-Jun-12	
TTIAXIAL ELF Magnetic Field Meter	SYPRIS	4090	4090070316	24-Aug-12	
EN61000-4-6					
RF-Generator	FRANKONIA	NSG2070	NSG2070	7-Nov-12	
CDN	SCHAFFNER	CDN M316	20653	11-Aug-12	
CDN	SCHAFFNER	CDN M316	19286	11-Aug-12	
CDN	FRANKONIA	RJ45	60050134	26-Jun-12	
Clamp	FRANKONIA	KEMZ801	19806	22-Oct-12	

※ Calibration interval of instruments listed above is one year

### **2.3 TEST PERFORMED**

Conducted emissions were investigated over the frequency range from 0.15MHz to 30MHz using a receiver which resolution bandwidth is set at 9 KHz.

Radiated emissions were investigated over the frequency range from 30MHz to 1000MHz using a receiver which resolution bandwidth is set at 120KHz. Radiated measurement was performed at distance that from an antenna to EUT is 10meters.



## **2.4 APPENDIX**

### **Appendix A: Measurement Procedure for Main Power Port Conducted Emissions**

The measurements are performed in a Global lab room; The EUT was placed on non-conductive 1.0m x 1.5m table, which is 0.8 meters above an earth-grounded.

Power to the EUT was provided through the LISN which has the Impedance (50ohm/50uH) vs. Frequency Characteristic in accordance with the standard. Powers to the LISNs were filtered to eliminate ambient signal interference and these filters were bonded to the ground plane. Peripheral equipment required to provide a functional system (support equipment) for EUT testing was powered from the second LISN through a ganged, metal power outlet box which is bonded to the ground plane at the LISN.

If the EUT is supplied with a flexible power cord, the power cord length in excess of the distance separating the EUT from the LISN shall be folded back and forth at the center of the lead so as to form a bundle not exceeding 40cm in length. If the EUT is provided with a permanently coiled power cord, bundling of the cord is not required. If the EUT is supplied without a power cord, the EUT shall be connected to the LISN by a power cord of the type specified by the manufacturer which shall not be longer than 1 meter. The excess power cord shall be bundled as described above. If a non-flexible power cord is provided with the EUT, it shall be cut to the length necessary to attach the EUT to the LISN and shall not be bundled.

The interconnecting cables were arranged and moved to get the maximum measurement. Both the line of power cord, hot and neutral, was measured.

The highest emissions were analyzed in details by operating the spectrum analyzer in fixed tuned mode to determine the nature of the emissions and to provide information which could be useful in reducing their amplitude.

### **Appendix B: Test Procedure for Radiated Emissions**

#### **Preliminary Measurements in the Anechoic Chamber**

The radiated emissions are initially measured in the anechoic chamber at a measurement distance of 3 meters. Desktop EUT are placed on a wooden stand 0.8 meter in height. The measurement antenna is 3 meters from the EUT. The test setup in anechoic chamber is the same as open site. The turntable rotated 360°C. The antenna height is 1m. The primary objective of the radiated measurements in the anechoic chamber is to identify the frequency spectrum in the absence of the electromagnetic environment existing on the open test site. The frequencies can then be pre-selected on the open test site to obtain the corresponding amplitude. The initial scan is made with the spectrum analyzer in automatic sweep mode. The spectrum peaks are then measured manually to determine the exact frequencies.



### **Measurements on the Open Site or Chamber**

The radiated emissions test will then be repeated on the open site or chamber to measure the amplitudes accurately and without the multiple reflections existing in the shielded room. The EUT and support equipments are set up on the turntable. Desktop EUT are set up on a wooden stand 0.8 meter above the ground.

For the initial measurements, the receiving antenna is varied from 1-4 meter height and is changed in the vertical plane from vertical to horizontal polarization at each frequency. Both reading are recorded with the quasi-peak detector with 120 KHz bandwidth. For frequency between 30 MHz and 1000MHz, the reading is recorded with peak detector or quasi-peak detector.

At the highest amplitudes observed, the EUT is rotated in the horizontal plane while changing the antenna polarization in the vertical plane to maximize the reading. The interconnecting cables were arranged and moved to get the maximum measurement. Once the maximum reading is obtained, the antenna elevation and polarization will be varied between specified limits to maximize the readings.

### 3. CONDUCTED EMISSION MEASUREMENT

#### 3.1 TEST SET-UP

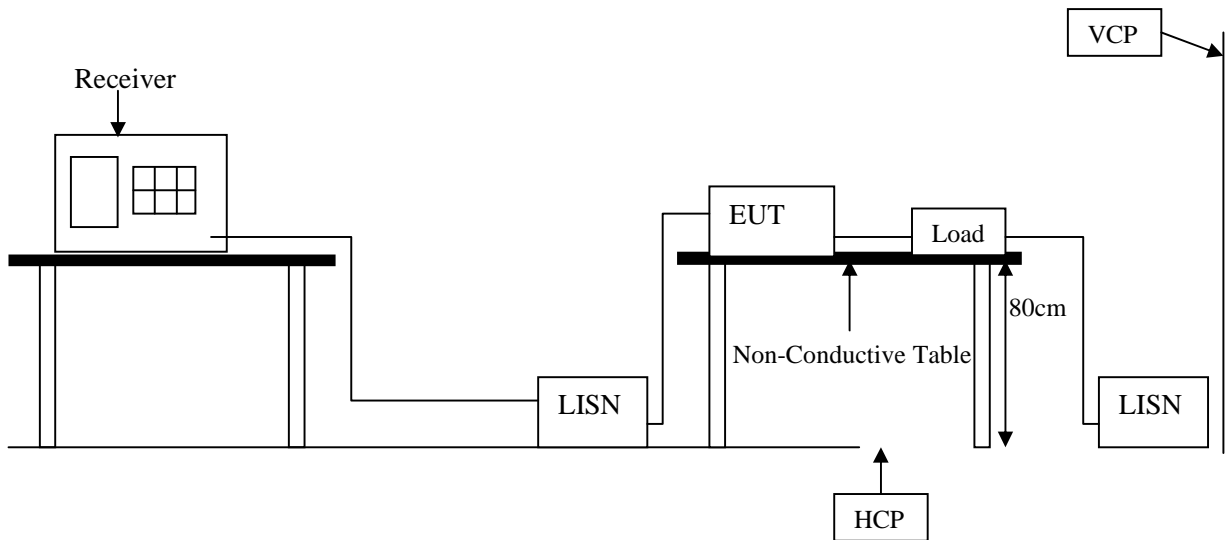

#### 3.2 LIMIT

Frequency range (MHz)	CLASS A		CLASS B	
	QP dB(uV)	Average dB(uV)	QP dB(uV)	Average dB(uV)
0.15-0.5	79 dBuV	66 dBuV	66 - 56 dBuV	56 - 46 dBuV
0.5-5.0	73 dBuV	60 dBuV	56 dBuV	46 dBuV
5.0-30.0	73 dBuV	60 dBuV	60 dBuV	50 dBuV

Remark: In the above table, the tighter limit applies at the band edges.

#### 3.3 TEST PROCEDURE

The EUT and simulators are connected to the main power through a line impedance stabilization network (LISN). It provides a 50 ohm / 50  $\mu$ H coupling impedance for the measuring equipment. The peripheral devices are also connected to the main power through a LISN that provides a 50 ohm / 50  $\mu$ H coupling impedance with 50 ohm termination. (Please refer to the block diagram of the test setup and photograph.)

Both sides of AC line are checked for the maximum conducted emission interference. In order to find the maximum emissions, the relating positions of equipment and all of the interference cables must be changed according to EN 55022 regulation: The measurement procedure on conducted emission interference.

The resolution bandwidth of the field strength meter is set at 9 KHz



### **3.4 TEST SPECIFICATION**

According to EN 55022

(Please refer to Page 4 for dated references which are related to the standard as mentioned above)

### **3.5 RESULT: PASSED**

EMI Receiver/Spectrum Analyzer Configuration (for the frequencies tested)

Frequency Range:	150KHz--30MHz
Detector Function:	Quasi-Peak / Average Mode
Resolution Bandwidth:	9KHz

### **3.6 TEST DATA:**

**Please refer to appendix 2**

## 4. RADIATED EMISSION MEASUREMENT

### 4.1 TEST SETUP

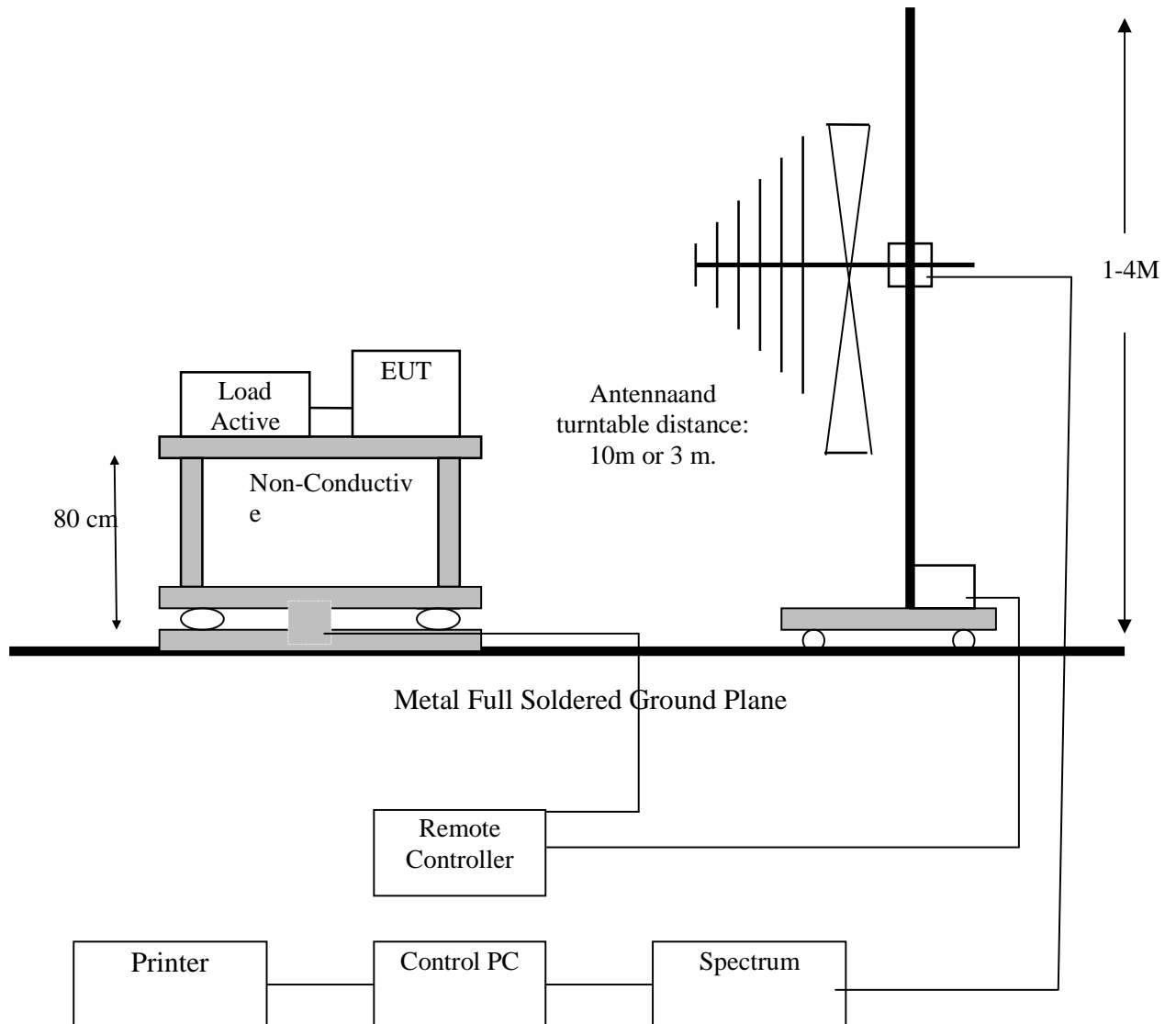



**4.2 LIMIT**

Frequency MHz	CLASS A		Class B	
	Distance (Meter)	Limit dB $\mu$ V/m	Distance (Meter)	Limit dB $\mu$ V/m
30 ~ 230	10	40	10	30
230 ~ 1000	10	47	10	37

For Class A

Frequency range GHz	Average limit dB( $\mu$ V/m)	Peak limit dB( $\mu$ V/m)
1 to 3	56	76
3 to 6	60	80
NOTE The lower limit applies at the transition frequency.		

For Class B

Frequency range GHz	Average limit dB( $\mu$ V/m)	Peak limit dB( $\mu$ V/m)
1 to 3	50	70
3 to 6	54	74
NOTE The lower limit applies at the transition frequency.		

Remark: In the above table, the tighter limit applies at the band edges.

**4.3 TEST PROCEDURE**

The EUT and its simulators are placed on turn table, non-conductive and wooden table, which is 0.8 meter above ground. The turn table rotates 360 degrees to determine the position of the maximum emission level. The EUT was positioned such that distance from antenna to the EUT is 10 meters.

The antenna is moved up and down between 1 meter and 4 meters to receive the maximum emission level.

Both horizontal and vertical polarizations of the antenna are set on measurement. In order to find the maximum emission, all of the interference cables must be manipulated according to EN 55022 regulations: the test procedure of the radiated emission measurement.

The bandwidth set on the field strength is 120 KHz when the frequency range is below 1GHz

**4.4 TEST SPECIFICATION**

According to EN 55022 CLASS B  
(Please refer to Page 4 for dated references which are related to the standard as mentioned above)



**4.5 RESULT: PASSED**

**4.6 TEST DATA:**

**Please refer to appendix 2**



## 5. POWER HARMONIC MEASUREMENT

### 5.1 TEST SETUP

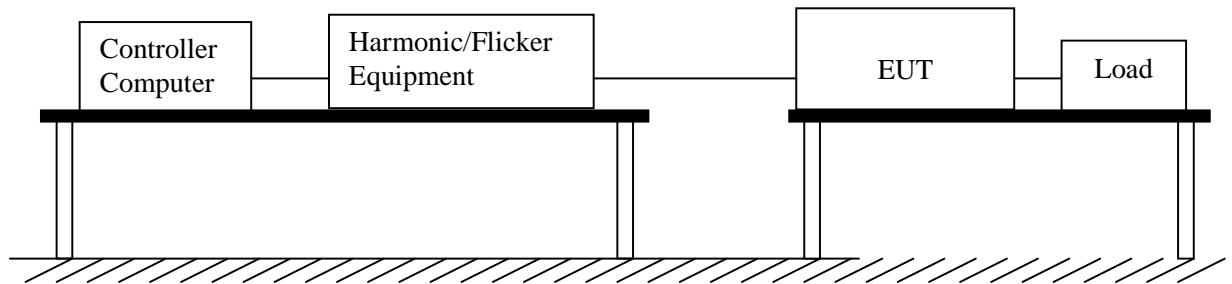

### 5.2 LIMIT OF HARMONIC CURRENT

Limit of Harmonic Currents

Harmonic Order	Maximum Permissible Harmonic Current (Ampere)	Harmonic Order	Maximum Permissible Harmonic Current (Ampere)
Odd Harmonic		Even Harmonic	
3	2.30	2	1.08
5	1.14	4	0.43
7	0.77	6	0.30
9	0.40	$8 \leq n \leq 40$	$0.23 \times 8/n$
11	0.33		
13	0.21		
$15 \leq n < 39$	$0.15 \times 15/n$		

### 5.3 TEST PROCEDURE

The EUT is supplied in series with power analyzer from a power source has the same normal voltage and frequency as the rated supply voltage and the equipment under test. The rated voltage at the supply voltage of EUT of 0.94 time and 1.06 times shall be performed.

### 5.4 TEST SPECIFICATION

According to EN 61000-3-2

(Please refer to Page 4 for dated references which are related to the standard as mentioned above)



**5.5 RESULT: PASSED**

**5.6 TEST DATA:**

**Please refer to appendix 2**



## **6. VOLTAGE FLUCTUATIONS**

### **6.1 TEST SETUP**

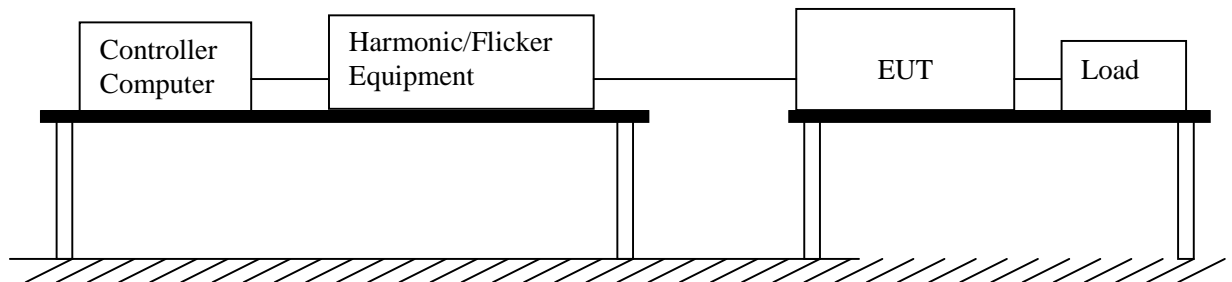

### **6.2 VOLTAGE FLUCTUATIONS TEST**

Port:	AC mains
Basic Standard:	EN 61000-3-3
Test Procedure	Refer to paragraph 6.3
Observation period:	For Pst 10min
	For Plt 2 hours

### **6.3 TEST PROCEDURE**

The EUT is supplied in series with reference impedance from a power source with the voltage and frequency as the nominal supply voltage and frequency of the EUT.

### **6.4 TEST SPECIFICATION**

According to EN 61000-3-3

According to EN55022 CLASS B

(Please refers to Page 4 for dated references which are related to the standard as mentioned above)

### **6.5 RESULT: PASSED**

### **6.6 TEST DATA:**

**Please refer to appendix 2**

## 7. ELECTROSTATIC DISCHARGE IMMUNITY TEST (ESD)

### 7.1 TEST PROCEDURE

According To IEC 61000-4-2

According To EN 55024

(Please refer to Page 4 for dated references which are related to the standard as mentioned above)

### 7.2 TEST SETUP

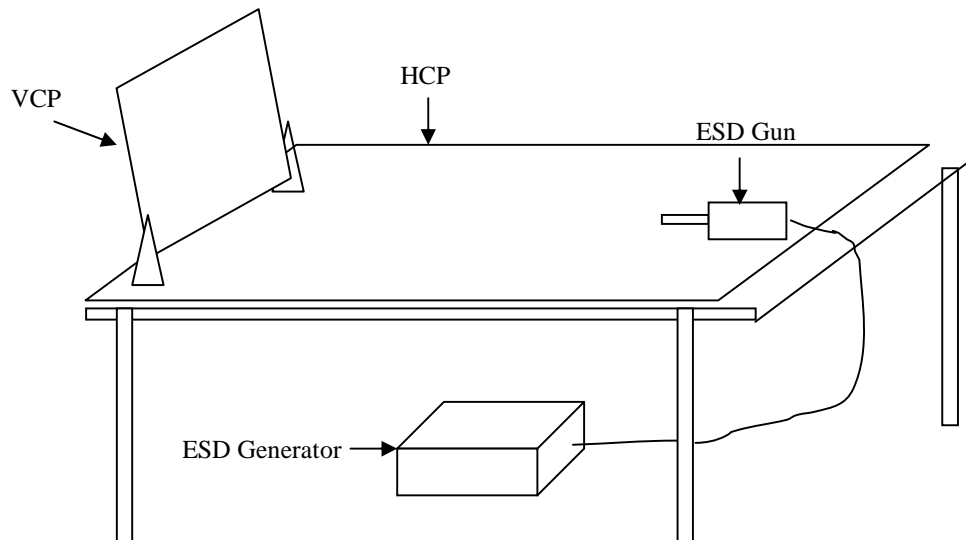

### 7.3 TEST LEVEL

Item	Test Specification	Unit	Performance Criteria
Enclosure Room	$\pm 2, 4, 8$ (Air Discharge)	KV (Charge Voltage)	B
Electrostatic Discharge	$\pm 2, 4$ (Contact Discharge)		
<b>Time between test</b>	<u>1</u>	sec	

Number of test: 10 Discharges / Test point / Polarity / Level

Particular requirements: at least 200 discharges, 100 each at negative and positive polarity, at a minimum of four test points.

When the measurement was taken, The ESD discharger was performed in single discharge. For the single discharge time between successive single discharges will keep on one second. It was at least ten single discharges with positive and negative at the same selected pointed. The selected pointed, which was performed with electrostatic discharge, was marked on the red label on the EUT

Indirect applicant of discharge to the EUT

Vertical Coupling Plane (VCP)



The coupling plane, of dimensions 0.5m x 0.5m, is placed parallel to, and positioned at a distance 0.1m from, the EUT, with the discharge electrode touching the coupling plane.

The four faces of the EUT will be performed with electrostatic discharge. It was at least ten singles discharges with positive and negative at the same selected point.

Horizontal Coupling Plane (HCP)

The coupling plane is placed under the EUT. The generator shall be positioned vertically at a distance of 0.1m from the EUT, with the discharge electrode touching the coupling.

The four faces of the EUT will be performed with electrostatic discharge. It was at least ten single discharges with positive and negative at the same selected pointed.

**7.4 TEST RESULT.**

Model: TTP111VP-LK

Temperature: 22°C , Humidity: 52 % RH

Test Point	Air Discharge	Contact Discharge	Performance Criteria	Result
HCP	----	±2, 4KV	A	<b>PASSED</b>
VCP	----	±2, 4KV	A	<b>PASSED</b>
I/O Port	±2, 4, 8KV	±2, 4KV	A	<b>PASSED</b>
CASE	±2, 4, 8KV	±2, 4KV	A	<b>PASSED</b>
SCREWS	----	±2, 4KV	A	<b>PASSED</b>

Final Result : **PASSED**

Remark:

**Photos of test configuration please refer to appendix 1.**

## 8. RADIATED SUSCEPTIBILITY MEASUREMENT (RS)

### 8.1 TEST SETUP

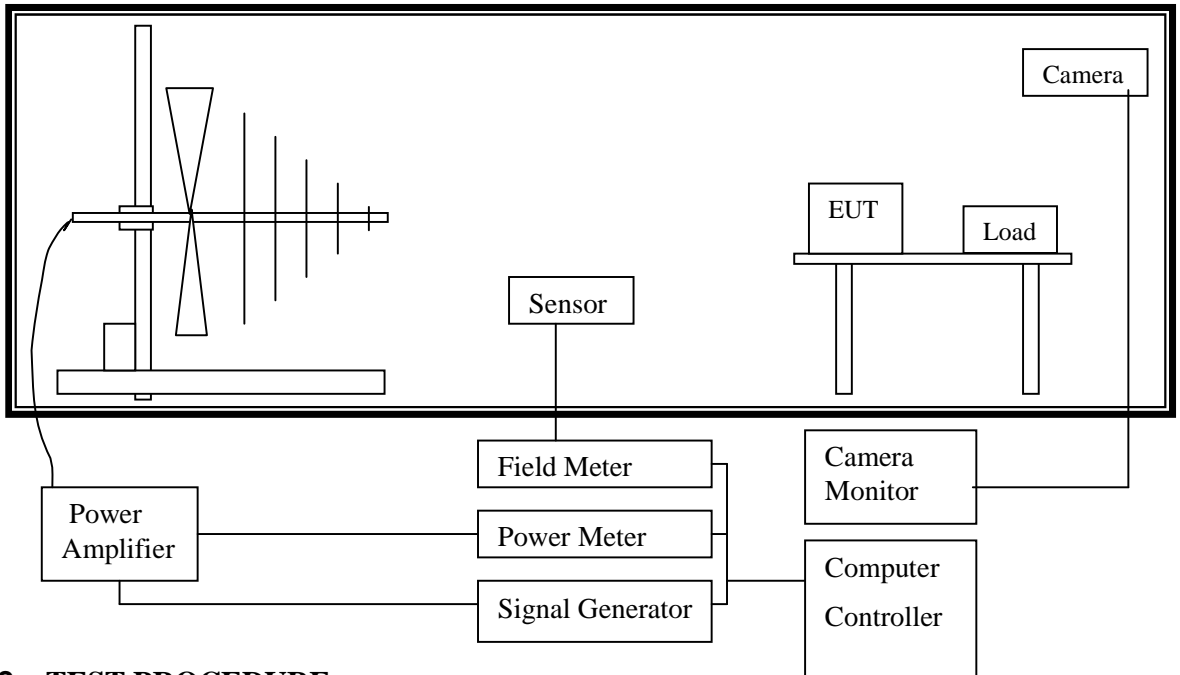

### 8.2 TEST PROCEDURE

According To IEC 61000-4-3

According To EN 55024

(Please refer to Page 4 for dated references which are related to the standard as mentioned above)

### 8.3 TEST LEVEL

Item	Test Specification	Unit	Performance Criteria
Radio -Frequency	80~1000	MHz	A
Electromagnetic Field	<b>3</b>	V/m (unmodulated, rms)	
Amplitude Modulated	80	%AM (1KHz)	



### 8.4 TEST PROCEDURE

The EUT and load, which are placed on a wooden table whose height is 0.8 meter aboveground, are placed with one coincident with the calibration plane such that the distance from antenna to the EUT is 3 meters.

Both horizontal and vertical polarization of the antenna position and four sides of the EUT are set on measurement. In order to judge the EUT performance, a CCD camera is used to monitor the situation of EUT.

All the scanning conditions are as follows:

Condition of Test	Remarks
1. Field Strength	3V/m; Level 2
2. Radiated Signal	AM 80% modulated with 1KHz
3. Scanning Frequencies	80MHz ~ 1000MHz
4. Dwell Time	3 seconds
5. Frequency step size	1%
6. The rate of swept of frequency	$1.5 \times 10^{-3}$ decades/s
7. Antenna Polarity	HORIZONTAL & VERTICAL
8. The four sides of EUT are tested	FRONT, REAR, RIGHT, LEFT

### 8.5 TEST RESULT

Model: TTP111VP-LK

Temperature: 22°C , Humidity: 52 % RH

ANT SIDE	3V HORIZONTAL	3V VERTICAL	RESULT
FRONT	A	A	<b>PASSED</b>
REAR	A	A	<b>PASSED</b>
RIGHT	A	A	<b>PASSED</b>
LEFT	A	A	<b>PASSED</b>

Final Result: **PASSED**

Remark:

**Photos of test configuration please refer to appendix 1.**

## 9. ELECTRICAL FAST TRANSIENT/BURST (EFT)

### 9.1 TEST SETUP

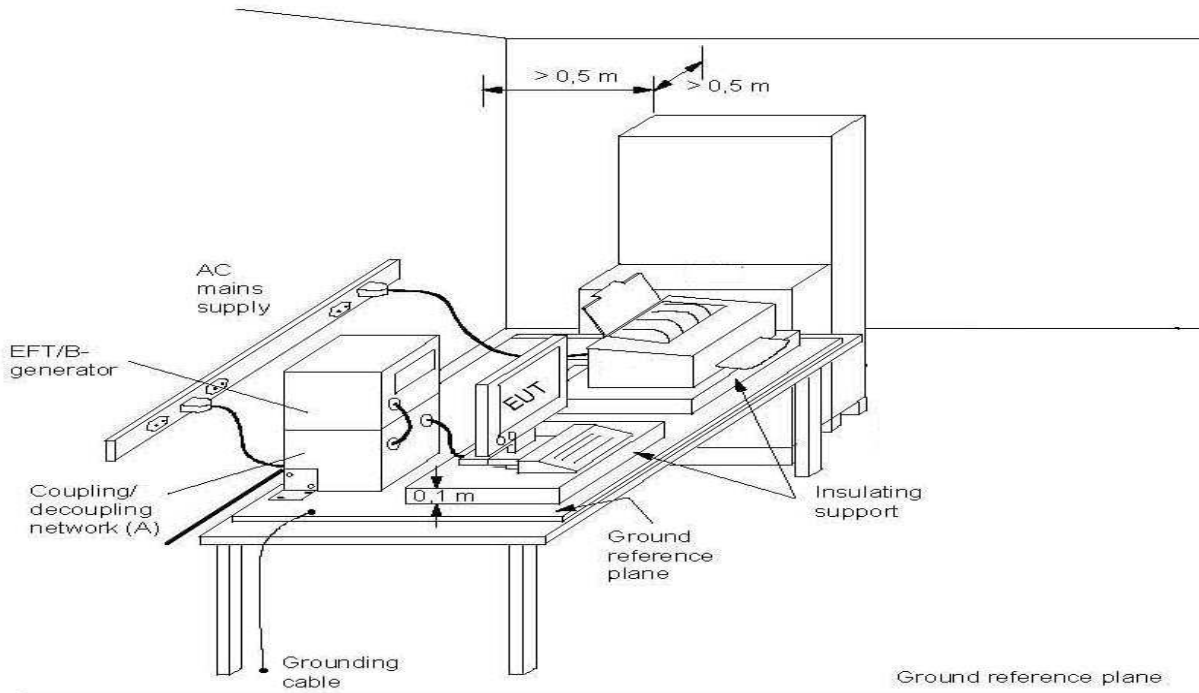

### 9.2 TEST PROCEDURE

According To IEC 61000-4-4

According To EN 55024

(Please refer to Page 4 for dated references which are related to the standard as mentioned above)

### 9.3 TEST PROCEDURE

The EUT and load are placed on a ground reference plane and insulated from it by an insulating support  $0,1\text{ m} \pm 0,01\text{ m}$  thick. The minimum area of the ground reference plane is  $1\text{ m} \times 1\text{ m}$ . It also projected beyond the EUT by at least 0.1meter on all sides.

For Input and Output AC power or DC Input and DC Output Power Ports:

The EUT is connected with the power mains through a coupling device that directly couples the EFT interference signal.

Each of the line and nature conductors is impressed with burst noise for 1 minute.

For Protective Earth Port:

The EUT is connected to the power mains through a coupling device that directly couples the EFT interference signal. The protective earth line (PE) is impressed with burst noise for 1 minute.

The length of power cord between the coupling device and the EUT shall be  $0,5\text{ m} \pm 0,05\text{ m}$ .

For signal Lines and Control Lines Test:

The EFT interference signal is through a coupling clamp device couples to the signal and control lines of the EUT with burst noise for 1 minute.



**9.4 TEST LEVEL**

Item	Test Specification	Unit	Performance Criteria
Test Voltage	±0.5, ±1	KV (Peak)	B
Pulse Rise time & Duration	5/50	Tr/Ts (ns)	
Pulse Repetition	5	Rep. Frequency (KHz)	
Coupling of power line	L, N, PE, L+N, L+PE, N+PE, L+N+PE		

**9.5 TEST RESULT:**

Model: TTP111VP-LK

Temperature: 22°C , Humidity: 52 % RH

Power Line			
TEST VOLTAGE	L	N	L+N
±0.5KV	A	A	A
±1KV	A	A	A

Final Result: **PASSED**

Remark:

**Photos of test configuration please refer to appendix 1.**



## 10. SURGE

### 10.1 TEST SETUP

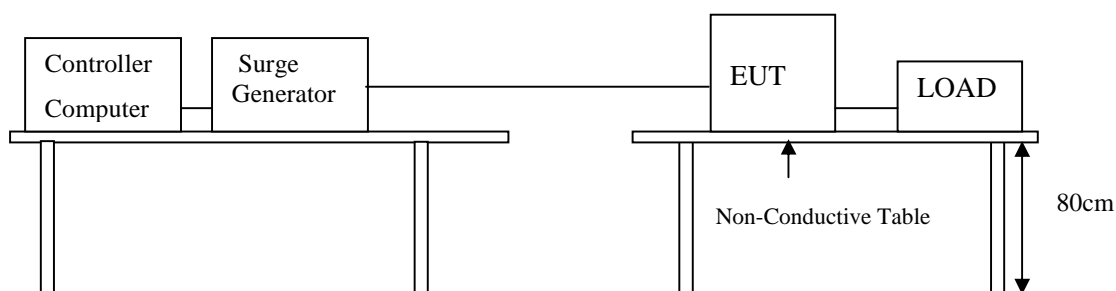

### 10.2 TEST PROCEDURE

According To IEC 61000-4-5

According To EN 55024

(Please refer to Page 4 for dated references which are related to the standard as mentioned above)

### 10.3 TEST LEVEL

Item	Test Specification	Unit	Performance Criteria
DC Input and DC Output Power Ports			
Surge	1.2/50(8/20)	Tr/Ts (μs)	B
Line to Ground	±0.5	KV	
Line to Line	±0.5	KV	
AC Input and AC Output Power Ports			
Surge	1.2/50(8/20)	Tr/Ts (μs)	B
Line to Ground	±2	KV	
Line to Line	±1	KV	
Polarity	POSITIVE / NEGATIVE		
Phase shifting in a range between 0° to 360°			



#### **10.4 TEST PROCEDURE**

The EUT and its load are placed on a table which is 0.8 meter height. The length of power cord between the coupling device and the EUT shall be 2 meters or less.

For Input and Output AC Power or DC Input and DC Output Power Ports:

The EUT is connected to the power mains through a coupling device that directly couples the Surge interference signal.

The Surge noise shall be applied synchronized to the voltage phase at 0°, 90°, 180°, 270° and the peak value of the AC voltage wave. (5 Positive and 5 Negative)

Each of line-earth and line-line is impressed with a sequence of five surge voltages with interval of 1 minute.

#### **10.5 TEST RESULT:**

Model: TTP111VP-LK

Temperature: 22°C , Humidity: 52 % RH

Environmental Phenomena	Test Specification	Units	Performance Criteria
Line to Line	±1	KV (Charge Voltage)	A

Final Result: **PASSED**

Remark:

**Photos of test configuration please refer to appendix 1.**



## 11. IMMUNITY TEST TO CS CONDUCTED DISTURBANCE (CS)

### 11.1 TEST SETUP

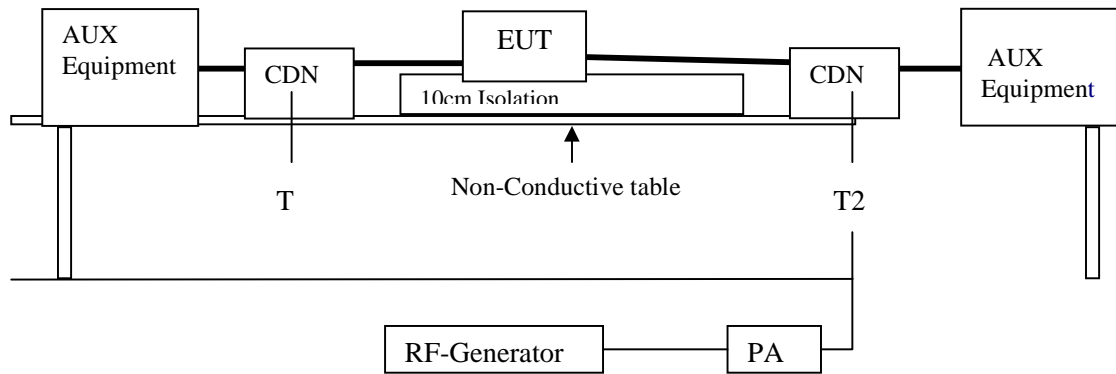

### 11.2 TEST PROCEDURE

According To IEC 61000-4-6

According To EN 55024

(Please refer to Page 4 for dated references which are related to the standard as mentioned above)

### 11.3 TEST LEVEL

Item	Test Specification	Unit	Performance Criteria
<b>Ports for Signal Lines</b>			
Radio-Frequency	0.15 ~ 80	MHz	A
Common Mode	3	V (rms, Unmodulated)	
Amplitude Modulated	80	% AM (1KHz)	
	150	Source Impedance	
<b>Ac Input and AC Output and DC Input and DC output Ports and Functional Earth Ports</b>			
Radio-Frequency	0.15 ~ 80	MHz	
Common Mode	3	V (rms, Unmodulated)	A
Amplitude Modulated	80	% AM (1KHz)	
	150	Source Impedance	



### 11.4 TEST PROCEDURE

The EUT are placed on a table which is 0.8 meter height and a ground reference plane on the table, the EUT are placed upon table and use 10cm insulation between the EUT and ground reference plane.

For AC Input and AC Output Power or DC Input and DC OutputPowerPorts

The EUT is connected to the power mains through a coupling and decoupling networks for Power supply lines. It also directly couples the disturbance signal into EUT.

Use CDN-M2 for two wires or CDN-M3 for three wires.

For Signal Lines and Control Lines Test:

The disturbance signal is through a coupling and decoupling networks (CDN) or EM-clamp which is to couple the signal and control lines of the EUT.

All scanning frequencies conditions are as following:

Condition of Test	Remarks
IEC 61000-4-6	
1. Field Strength	3V; Level 2
2. Radiated Signal	AM 80% modulated with 1KHz
3. Scanning Frequencies	0.15MHz ~ 80MHz
4. Dwell Time	3 seconds
5. Frequency step size $\Delta f$	1%
6. The rate of swept of frequency	$1.5 \times 10^{-3}$ decades/s

### 11.5 TEST RESULT:

Model: TTP111VP-LK

Temperature: 22°C , Humidity: 52 % RH

TEST Specification	Unit	Performance Criteria
0.15 - 80	MHz	A
3	V	
80	% AM (1KHz)	

Final Result: **PASSED**

Remark:

**Photos of test configuration please refer to appendix 1.**

## 12. POWER FREQUENCY MAGNETIC FIELD (MAGNETIC)

### 12.1 TEST SETUP

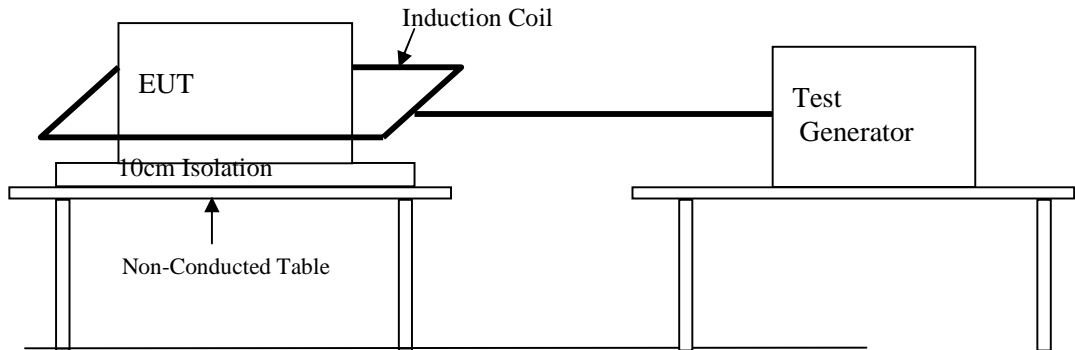

### 12.2 TEST STANDARD

According To IEC 61000-4-8

According To EN 55024

(Please refer to Page 4 for dated references which are related to the standard as mentioned above)

### 12.3 TEST LEVEL

Item	Test Specification	Unit	Performance Criteria
Power-Frequency	50	Hz	A
Magnetic Field	1	A/m	

### 12.4 TEST PROCEDURE

The EUT and its load are placed on a table that is 0.8 meter above the metal ground plane dimension is at least 1 meter x 1 meter. The test magnetic field shall be placed at least than 3 meter distance from the induction coil.

The test magnetic field shall be applied by the immersion method to the EUT. The induction coil shall be rotated by 90° in order to expose the EUT to the test field with different orientation (X, Y, Z orientation).



## 12.5 TEST RESULT

Model: TTP111VP-LK

Temperature: 22°C , Humidity: 52 % RH

Environmental Phenomena	Test Specification	Units	Performance Criteria
Magnetic Field	1	A/m	A

Final Result: **PASSED**

Remark:

**Photos of test configuration please refer to appendix 1.**



## **13. VOLTAGE DIPS AND INTERRUPTION MEASUREMENT**

### **13.1 TEST SETUP**

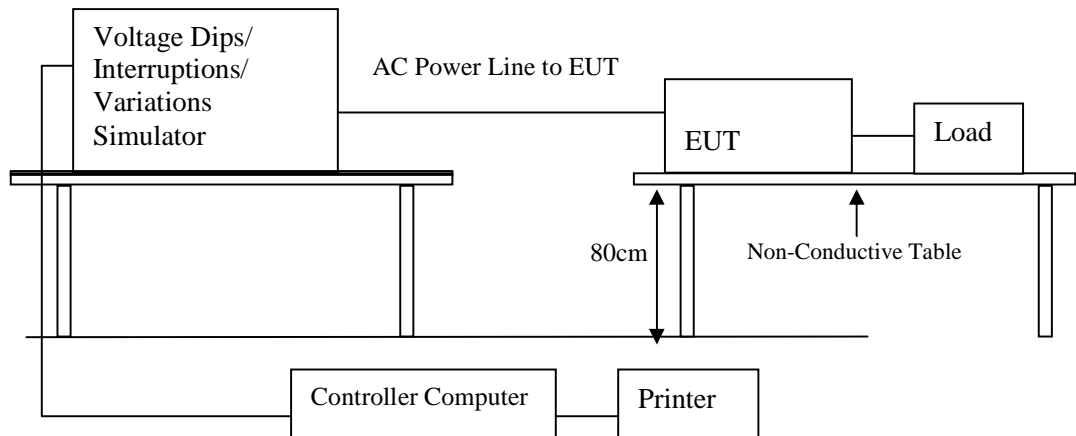

### **13.2 TEST PROCEDURE**

According To IEC 61000-4-11

According To EN 55024

(Please refer to Page 4 for dated references which are related to the standard as mentioned above)



**13.3 TEST LEVEL**

Class <sup>a</sup>	Test level and durations for voltage dips				
Class 1	Case-by-case according to the equipment requirements				
Class 2	0 % during 1/2 cycle	0 % during 1 cycle	70 % during 25/30 <sup>c</sup> cycles		
Class 3	0 % during 1/2 cycle	0 % during 1 cycle	40 % during 10/12 <sup>c</sup> cycles	70 % during 25/30 <sup>c</sup> cycles	80 % during 250/300 <sup>c</sup> cycles
Class X <sup>b</sup>	X	X	X	X	X

a: Classes as per IEC 61000-2-4.  
b: To be defined by product committee. For equipment connected directly or indirectly to the public network, the levels must not be less severe than Class 2.  
c: “25/30 cycles” means “25 cycles for 50 Hz test” and “30 cycles for 60 Hz tet”.

Class <sup>a</sup>	Test level and durations for short interruptions (t <sub>s</sub> ) (50Hz / 60Hz)
Class 1	Case-by-case according to the equipment requirements
Class 2	0 % during 250/300 <sup>c</sup> cycles
Class 3	0 % during 250/300 <sup>c</sup> cycles
Class X <sup>b</sup>	X

a: Classes as per IEC 61000-2-4.  
b: To be defined by product committee. For equipment connected directly or indirectly to the public network, the levels must not be less severe than Class 2.  
c: “250/300 cycles” means “250 cycles for 50 Hz test” and “300 cycles for 60 Hz test”.

**13.4 TEST PROCEDURE**

The EUT and its load are placed on a wooden table which is 0.8 meter above a metal ground plane which dimension is 1 meter x 1 meter, the thickness is 0.65mm. It projected beyond the EUT by at least 0.1 meter on all sides. The power cord shall be used the shortest power cord as specified by the manufacturer.

For Voltage Dips / Interruption Test:

The EUT is connected to the power mains through a coupling device that directly couples to the Voltage Dips and Interruption Generator.

The EUT shall be tested for 30% voltage dips of supplied voltage and duration time is 10ms, for 60% voltage dips of supplied voltage and duration time is 100ms with a sequence of three voltage dips with intervals of 10 seconds, and for 95% voltage interruption of supplied voltage and the duration time is 5000ms with a sequence of three voltage interruptions with intervals of 10 seconds.

Voltage phase shifting are shall occur at 0°, 45 °, 90 °, 135 °, 180 °, 225 °, 270 °, 315 ° of the voltage.



**13.5 TEST RESULT:**

Model: TTP111VP-LK  
Temperature: 22°C , Humidity: 52 % RH

Voltage Dips	Test Level % U <sub>T</sub>	Reduction (%)	Duration	Performance Criteria
	<5	>95	0.5 (periods)	A
	70	30	25 (periods)	C

Voltage Dips	Test Level % U <sub>T</sub>	Reduction (%)	Duration	Performance Criteria
	70	30	10ms	A
	40	60	100 and 1000ms	C

Voltage Dips	Test Level % U <sub>T</sub>	Reduction (%)	Duration	Performance Criteria
	<5	>95	250(periods) 5000ms	C

Final Result: **PASSED**

Remark:

**Please refer to appendix 2.**



#### **14. PERFORMANCE CRITERIA**

- A. The apparatus shall continue to operate as intended during and after the test. No degradation of performance or loss of function is allowed below a performance level specified by the manufacturer, when the apparatus is used as intended.
- B. The apparatus shall continue to operate as intended after the test. No degradation of performance or loss of function is allowed below a performance level specified by the manufacturer, when the apparatus is used as intended. The performance level may be replaced by a permissible loss of performance. During the test, degradation of performance is however allowed.
- C. Temporary loss of function is allowed, provided the function is self-recoverable or can be restored by the operation of the controls.



## 15. MEASUREMENT UNCERTAINTY

The uncertainty is calculated in accordance with CISPR16-4-2, the total uncertainty for this test is as follows:

### Uncertainty of Conducted Emission Measurement

Contribution	Probability Distribution	150KHz – 30MHz
Receiver reading	Normal (k=2)	±0.2
Cable loss	Normal (k=2)	±0.1
AMN insertion loss	Rectangular	±0.2
RCV/SPA specification	Rectangular	±0.9
combined standard uncertainty $U_e(y)$	normal	±1.0
Measuring uncertainty for a level of confidence of 95% $U=2U_e(y)$	normal (k=2)	±2.0

### Uncertainty of Radiated Emission Measurement

Contribution	Probability Distribution	30MHz~1GHz
Receiver reading	Normal (k=2)	±0.2
Cable loss calibration	Normal (k=2)	±0.1
Antenna factor calibration	Rectangular	±0.4
Pre Amplifier Gain calibration	Rectangular	±0.3
RCV/SPA specification	Rectangular	±0.9
combined standard uncertainty $U_e(y)$	normal	±1.1
Measuring uncertainty for a level of confidence of 95% $U=2U_e(y)$	normal (k=2)	±2.2

## **Appendix 1**

### **PHOTOS OF TEST CONFIGURATION**

01 CON-F



02 CON-R



03 RAD-F



04 RAD-R



05 Harmonics & Flicker & Surge & DIPS



06 ESD



07 RS



08 EFT



09 CS

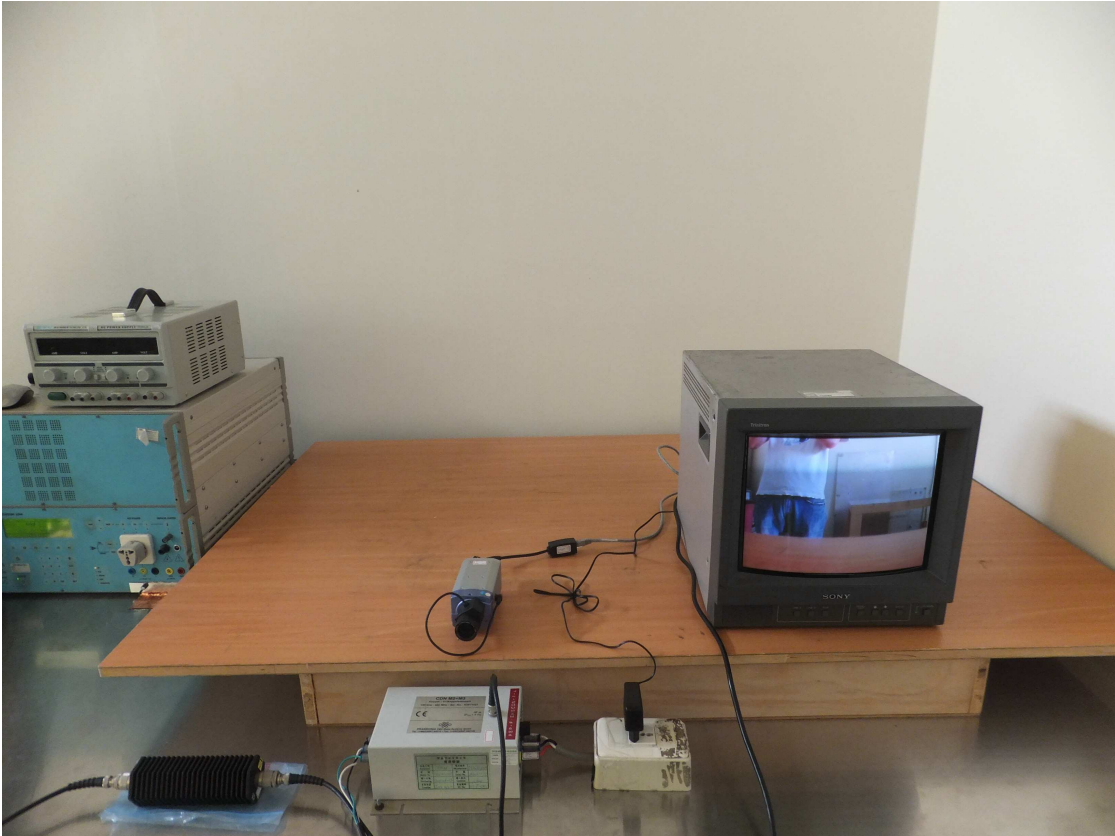

10 PFMF

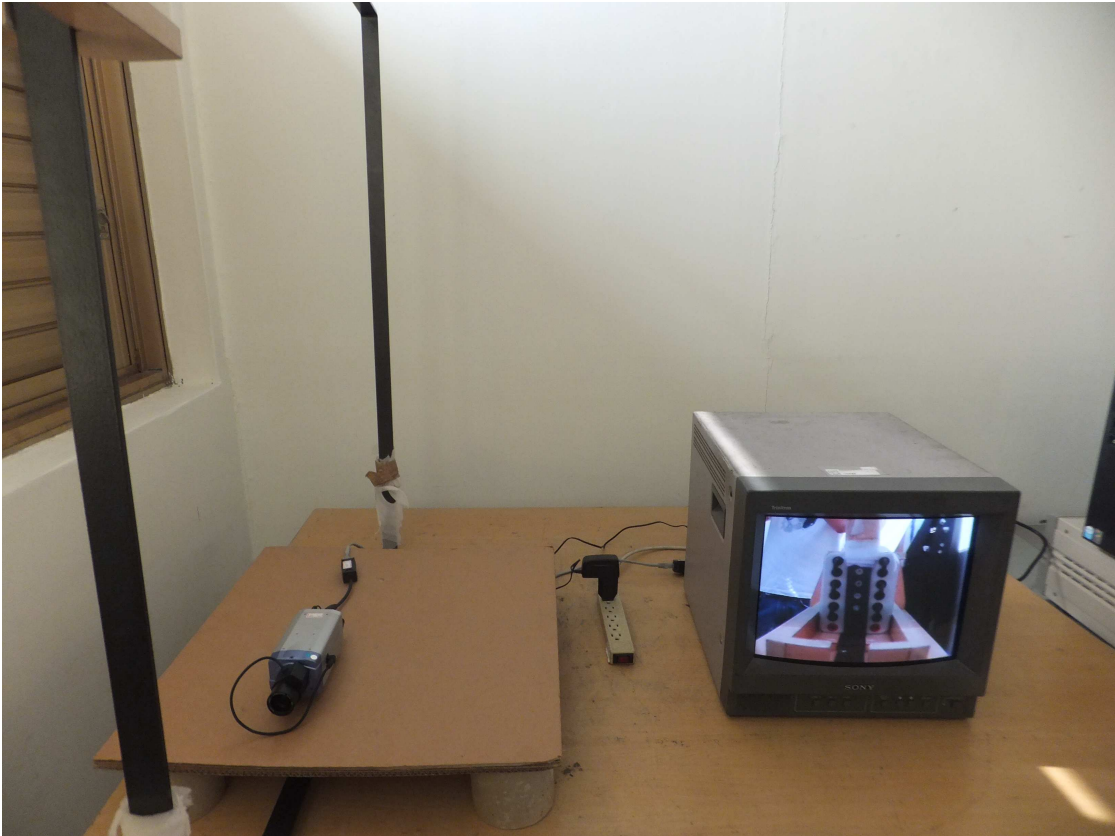

**Appendix 2**  
**TEST DATA**



Data: 1

File: D:\CON數據\案件數據\12051708\12051708-101-0523.EM6 (2)

Date: 2012-05-23 Time: 13:19:01

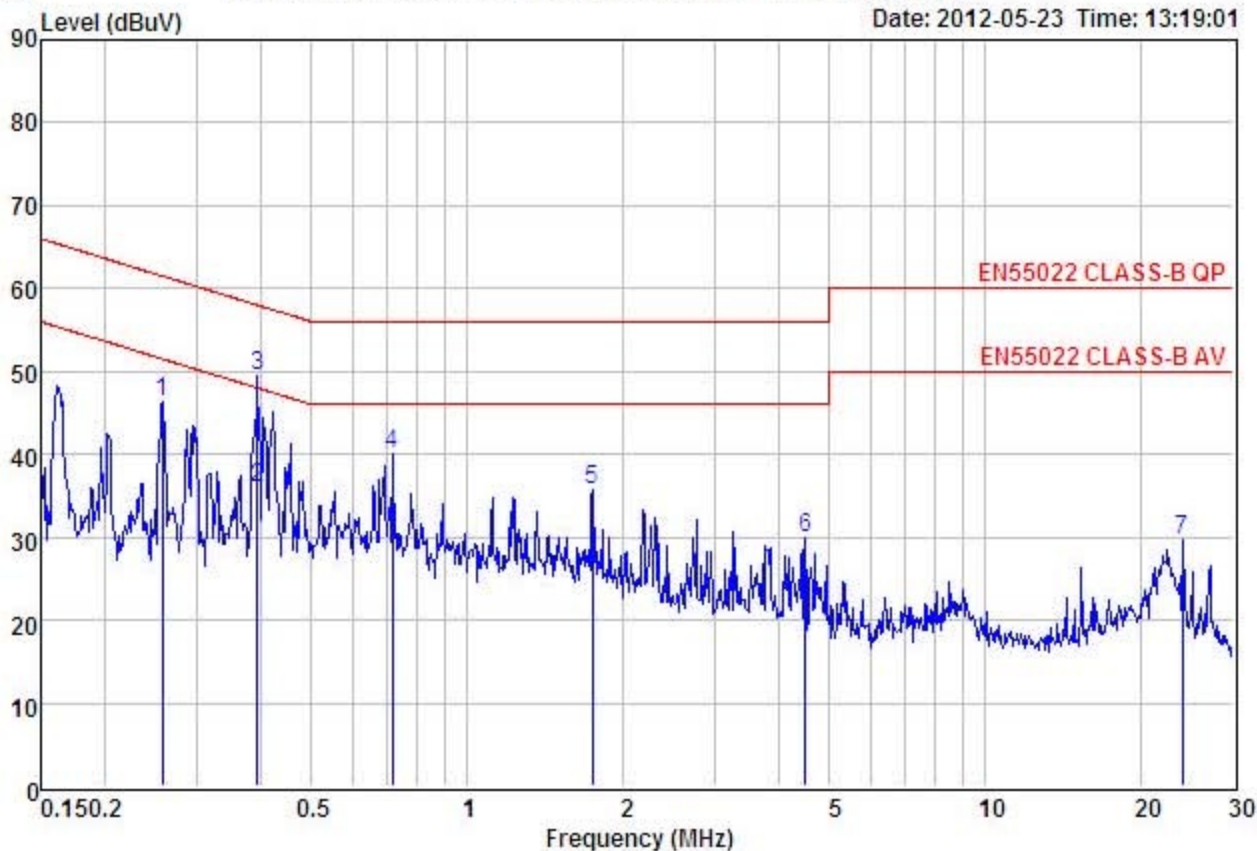

Site : Conduction

Condition: EN55022 CLASS-B QP CON-LISN(101-0413) LINE

EUT : Please refer to page 1 of report

MODEL : Please refer to page 1 of report

MEMO :

T/H :

	Freq	Read Level	Level	Factor	Over Limit	Limit Line	Remark
	MHz	dBuV	dBuV	dB	dB	dBuV	
1	0.26	46.33	46.22	-0.11	-15.29	61.51	Peak
2	0.39	36.00	35.87	-0.13	-12.12	47.99	Average
3	0.39	49.69	49.56	-0.13	-8.43	57.99	Peak
4	0.72	40.17	40.01	-0.16	-15.99	56.00	Peak
5	1.74	35.94	35.72	-0.22	-20.28	56.00	Peak
6	4.48	30.23	29.92	-0.31	-26.08	56.00	Peak
7	24.01	30.42	29.74	-0.68	-30.26	60.00	Peak



Data: 2

File: D:\CON數據\案件數據\12051708\12051708-101-0523.EM6 (2)

Date: 2012-05-23 Time: 13:21:09

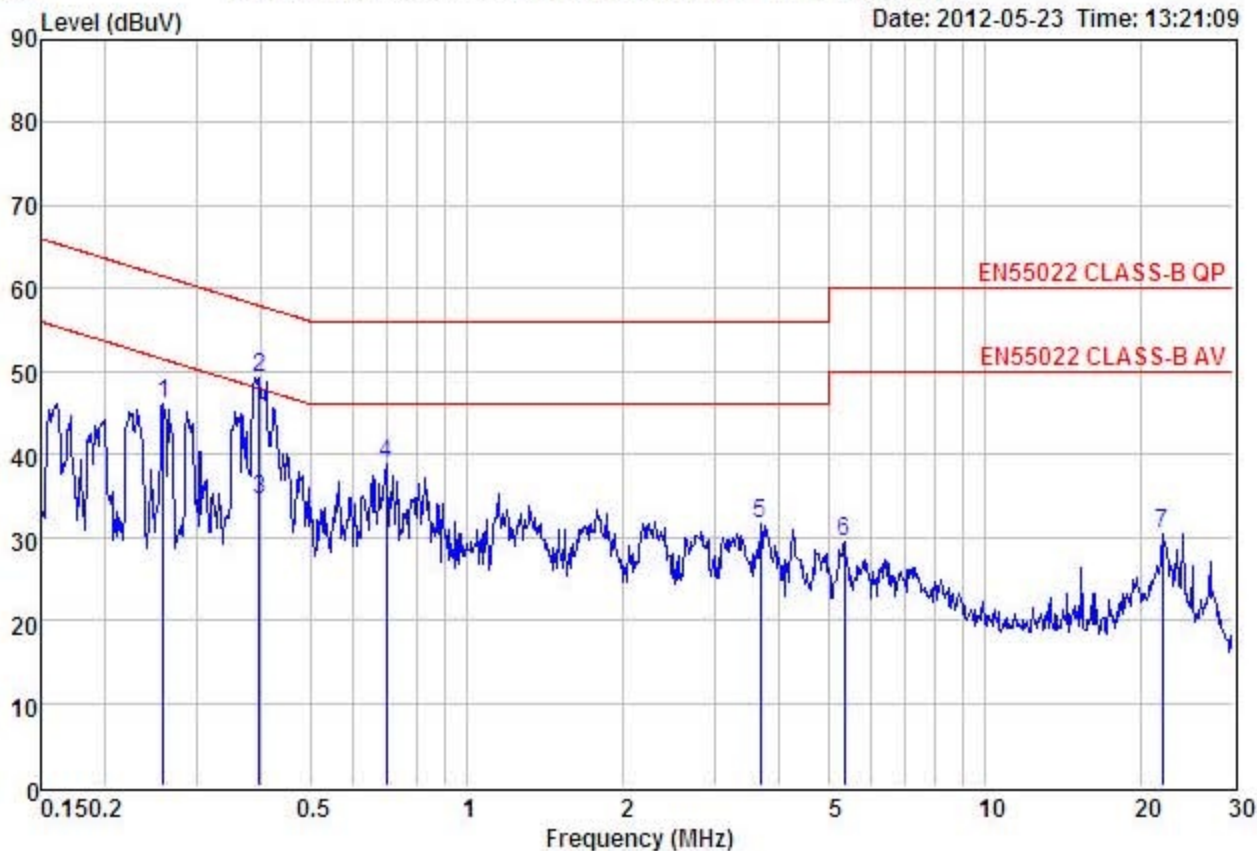

Site : Conduction

Condition: EN55022 CLASS-B QP CON-LISN(101-0413) NEUTRAL

EUT : Please refer to page 1 of report

MODEL : Please refer to page 1 of report

MEMO :

T/H :

	Freq	Read Level	Level Factor	Over Limit	Limit Line	Remark
	MHz	dBuV	dBuV	dB	dBuV	
1	0.26	46.17	46.06	-0.11	-15.41	61.47 Peak
2	0.40	49.36	49.23	-0.13	-8.72	57.95 Peak
3	0.40	34.58	34.45	-0.13	-23.50	57.95 Peak
4	0.70	38.95	38.80	-0.15	-17.20	56.00 Peak
5	3.68	31.86	31.56	-0.30	-24.44	56.00 Peak
6	5.33	29.78	29.43	-0.35	-30.57	60.00 Peak
7	21.95	31.03	30.37	-0.66	-29.63	60.00 Peak



Data: 1

File: C:\Documents and Settings\CH\桌面\案件\12051708\12051708-DATA\12051708-101-0524.EM6 (

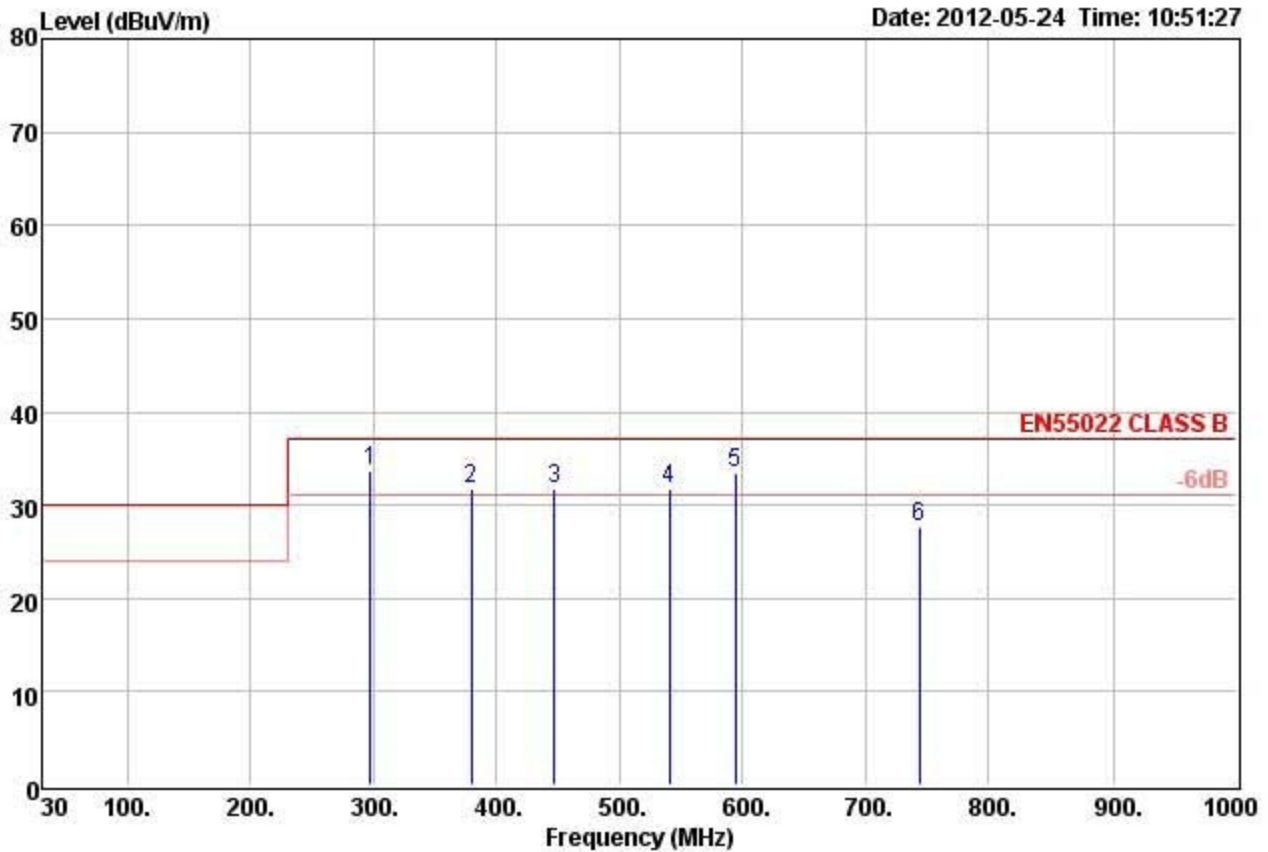

Site : open site  
 Condition: EN55022 CLASS B 10m 9161(30M-1G)-101-H HORIZONTAL  
 EUT : Please refer to page 1 of report  
 MODEL : Please refer to page 1 of report  
 MEMO :

	Freq	Level	Read Level	Over	Limit	Remark
	MHz	dBuV/m	dBuV	Factor	dB	dBuV/m
1 !	297.72	33.74	48.84	-15.10	-3.26	37.00 QP
2 !	379.20	31.83	42.14	-10.31	-5.17	37.00 QP
3 !	447.10	31.78	41.28	-9.50	-5.22	37.00 QP
4 !	540.23	31.72	38.94	-7.22	-5.28	37.00 QP
5 !	594.54	33.39	39.36	-5.97	-3.61	37.00 QP
6	743.92	27.75	31.25	-3.50	-9.25	37.00 QP



Data: 2

File: C:\Documents and Settings\CH\桌面\案件\12051708\12051708-DATA\12051708-101-0524.EM6 (

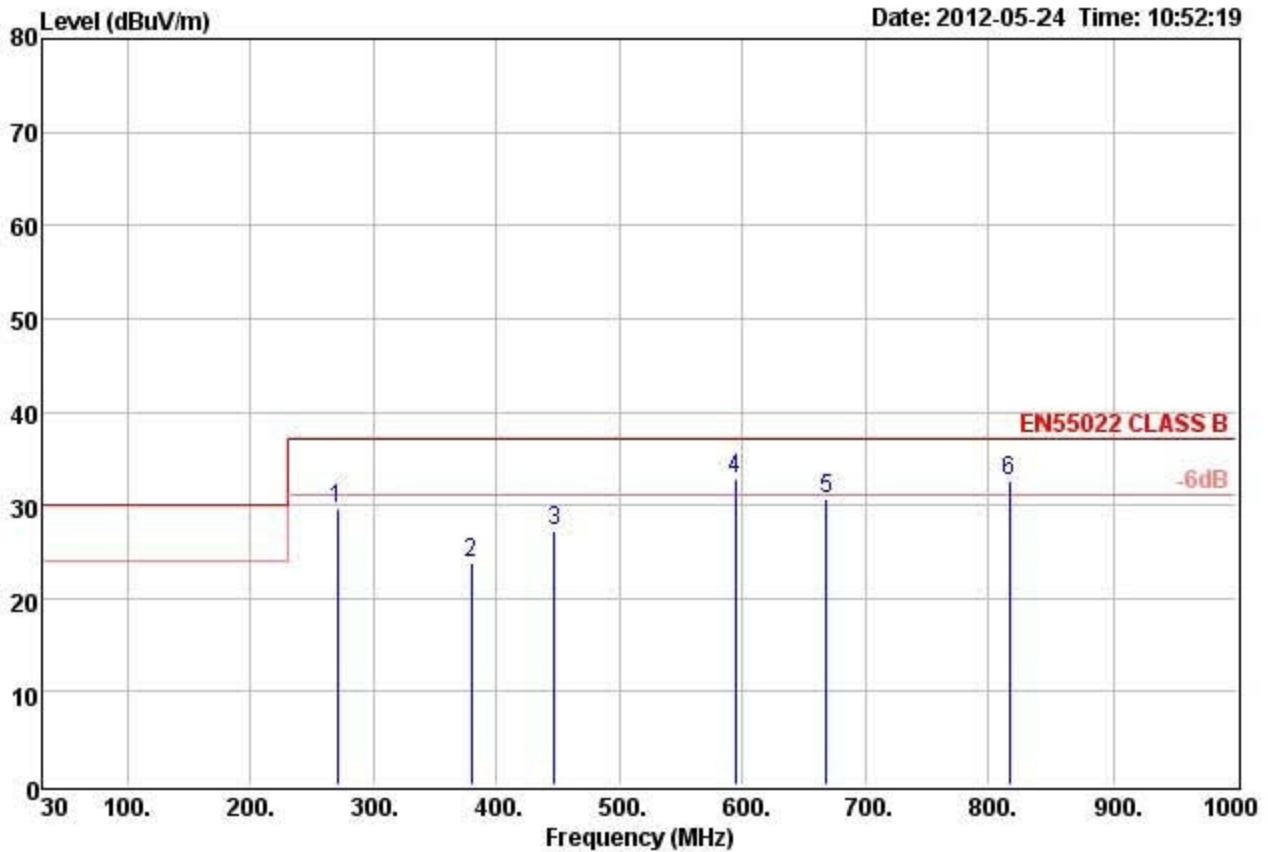

Site : open site  
 Condition: EN55022 CLASS B 10m 9161(30M-1G)-101-V VERTICAL  
 EUT : Please refer to page 1 of report  
 MODEL : Please refer to page 1 of report  
 MEMO :

	Freq	Level	Read Level	Over	Limit	Remark
	MHz	dBuV/m	dBuV	Factor	dB	dBuV/m
1	270.56	29.69	45.48	-15.79	-7.31	37.00 QP
2	379.20	23.88	38.36	-14.48	-13.12	37.00 QP
3	447.10	27.33	41.83	-14.50	-9.67	37.00 QP
4 !	594.54	32.81	38.33	-5.52	-4.19	37.00 QP
5	668.26	30.66	35.03	-4.37	-6.34	37.00 QP
6 !	817.64	32.52	33.81	-1.29	-4.48	37.00 QP

File :

Operator

Unit 12051708

Serial Number

Remarks

Urms = 230.7V Freq = 60.019 Range: 1 A

Irms = 0.042A Ip<sub>k</sub> = 0.210A cf = 5.012

P = 4.270W S = 9.687VA pf = 0.441

THDi = 90.8 % THDu = 0.10 % Class A

Test completed, Result: PASSED

Order	Freq.	Iavg	Irms	Imax	Limit	Status
	[Hz]	[A]	[A]	[A]		
1	60	0.0180	0.0184	0.0187		
2	120	0.0000	0.0004	0.0007	1.0800	
3	180	0.0154	0.0158	0.0161	2.3000	
4	240	0.0000	0.0004	0.0007	0.4300	
5	300	0.0151	0.0155	0.0157	1.1400	
6	360	0.0000	0.0004	0.0007	0.3000	
7	420	0.0145	0.0149	0.0151	0.7700	
8	480	0.0000	0.0004	0.0007	0.2300	
9	540	0.0137	0.0140	0.0142	0.4000	
10	600	0.0000	0.0004	0.0007	0.1840	
11	660	0.0127	0.0130	0.0132	0.3300	
12	720	0.0000	0.0004	0.0006	0.1533	
13	780	0.0115	0.0118	0.0120	0.2100	
14	840	0.0000	0.0004	0.0006	0.1314	
15	900	0.0103	0.0106	0.0107	0.1500	
16	960	0.0000	0.0004	0.0006	0.1150	
17	1020	0.0090	0.0092	0.0093	0.1324	
18	1080	0.0000	0.0004	0.0005	0.1022	
19	1140	0.0077	0.0079	0.0079	0.1184	
20	1200	0.0000	0.0004	0.0005	0.0920	
21	1260	0.0063	0.0066	0.0066	0.1071	
22	1320	0.0000	0.0004	0.0005	0.0836	
23	1380	0.0049	0.0054	0.0054	0.0978	
24	1440	0.0000	0.0004	0.0005	0.0767	
25	1500	0.0000	0.0043	0.0043	0.0900	

26	1560	0.0000	0.0003	0.0004	0.0708
27	1620	0.0000	0.0034	0.0034	0.0833
28	1680	0.0000	0.0003	0.0004	0.0657
29	1740	0.0000	0.0026	0.0026	0.0776
30	1800	0.0000	0.0003	0.0004	0.0613
31	1860	0.0000	0.0021	0.0021	0.0726
32	1920	0.0000	0.0003	0.0004	0.0575
33	1980	0.0000	0.0018	0.0018	0.0682
34	2040	0.0000	0.0002	0.0003	0.0541
35	2100	0.0000	0.0017	0.0018	0.0643
36	2160	0.0000	0.0002	0.0003	0.0511
37	2220	0.0000	0.0018	0.0018	0.0608
38	2280	0.0000	0.0002	0.0003	0.0484
39	2340	0.0000	0.0018	0.0018	0.0577
40	2400	0.0000	0.0002	0.0002	0.0460

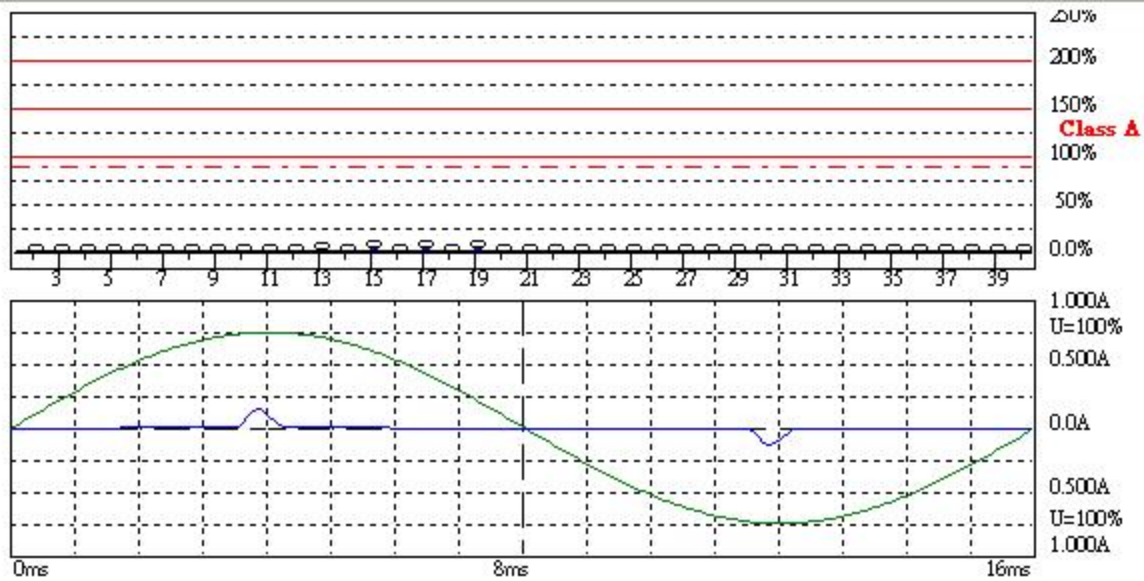

File :

Operator

Unit 12051708

Serial Number

Remarks

Urms = 230.7V Freq = 60.019 Range: 1 A

Irms = 0.043A Ipk = 0.222A cf = 5.159

P = 4.295W S = 9.913VA pf = 0.433

LIN (Line Impedance Network) : L: 0.24ohm +j0.15ohm N: 0.16ohm +j0.10ohm

Limits : Plt : 0.65 Pst : 1.00

dmax : 4.00 % dc : 3.00 %

dtLim: 3.00 % dt>Lim: 200ms

Test completed, Result: PASSED

dmax

[%]

1 0.000

Flickermeter 1000-4-15 for 120V/60Hz

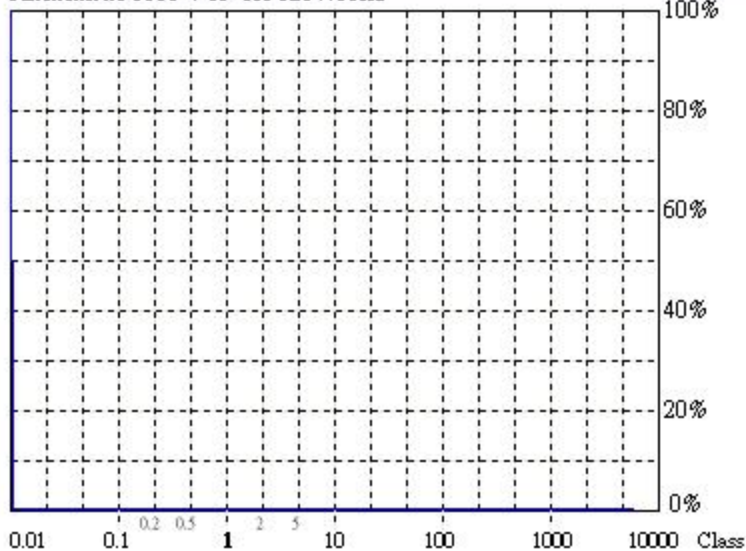

**Actual Flicker (Fli):** 0.00

**Short-term Flicker (Pst):** 0.07

Limit (Pst): 1.00

**Long-term Flicker (Plt):** 0.07

Limit (Plt): 0.65

**Maximum Relative  
Volt. Change (dmax):** 0.00%

Limit (dmax): 4.00%

**Relative Steady-state  
Voltage Change (dc):** 0.01%

Limit (dc): 3.00%

**Maximum Interval  
exceeding 3.00% (dt):** 0.00ms

Limit (dt>Lim): 200ms