



ADDRESS: No. 67-9, Shir Men Road, Tu Cheng City,
Taipei Hsien, Taiwan

PHONE : 886-2-22608375 FAX : 886-2-22748013

E - mail : hometek@ms15.hinet.net

CE TEST REPORT FOR

APPLICANT : Smart Home Engineering Corp.
ADDRESS : 10F., No. 493, Chung-Cheng Rd.,
Hsin-Tien City, Taipei 231, Taiwan, R. O. C.
Receipt Date : 05/15/2007 Final Test Date: 05/31/2007
EUT : USB CAT5 extender with 4 port USB hub
MODEL NO. : UE0XXX

MEASUREMENT PROCEDURE USED

EN55022 CLASS B / EN61000-3-2 / EN61000-3-3 / EN55024 GIVEN IN
EUROPEAN COUNCIL DIRECTIVE 2004/108/EC

This test result of this report applies to above tested sample only.

This test report shall not be reproducing in part without written approval of HomeTek Technology Inc.

PREPARED BY :

HomeTek Technology Inc.

No. 67-9, Shir Men Road, Tu Cheng City,

Taipei Hsien. Taiwan

Report # : EB6K038

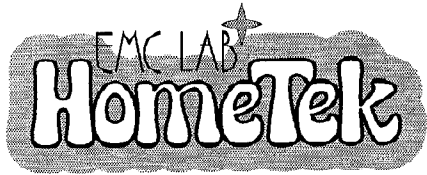

HomeTek Technology Inc.

ADDRESS: No. 67-9, Shir Men Road, Tu Cheng City,
Taipei Hsien

PHONE : 886-2-22608375 FAX : 886-2-22748013

E - mail : hometek@ms15.hinet.net

CERTIFICATE OF COMPLIANCE

EUT : USB CAT5 extender with 4 port USB hub
MODEL NO. : UE0XXX
Receipt Date : 05/15/2007 Final Test Date: 05/31/2007
REPORT # : EB6K038
APPLICANT : Smart Home Engineering Corp.
ADDRESS : 10F., No. 493, Chung-Cheng Rd.,
Hsin-Tien City, Taipei 231, Taiwan, R. O. C.

Measurement procedure used:

EMI: EN 55022 Class B (1998) + A1 (2000) + A2 (2003),

EN 61000-3-2 (2000), EN 61000-3-3 (1995) + A1 (2001)

EMS: EN 55024 (1998) + A1 (2001) + A2 (2003):

IEC 61000-4-2 (2001), IEC 61000-4-3 (2002), IEC 61000-4-4 (2004), IEC 61000-4-5 (2001),

IEC 61000-4-6 (2003) + A1 (2004), IEC 61000-4-8 (2001), IEC 61000-4-11 (2004)

We hereby show that:

The measurements shown in this test report were made in accordance with the procedures given in **EUROPEAN COUNCIL DIRECTIVE 2004/108/EC**, and the energy emitted by the equipment was found to be within the limits applicable. This product, which has been issued the test report listed as above in HomeTek Technology Inc., is based on single evaluation of one sample and confirmed to comply with the requirements of the above-mentioned EMC standard.

This test report is a duplicate of original one (report No. EB6E022, issued on 2007, 06, 01),
applicant and model No. is modified.

APPROVED BY : 

ALAIN LIN / Assistant Manage

TEST REPORT CERTIFICATION**EMC of electrical appliances**

Report reference No. : EB6K038
Date of issue : DEC., 14, 2007
Applicant : Smart Home Engineering Corp.
Address : 10F., No. 493, Chung-Cheng Rd.,
Hsin-Tien City, Taipei 231, Taiwan, R. O. C.
Manufacturer : Smart Home Engineering Corp.
Type of test object : USB CAT5 extender with 4 port USB hub
Model/type reference : UE0XXX
Rated Voltage : N/A
EUT Voltage : N/A
Test Result : Complied
Testing laboratory : HomeTek Technology Inc.
Address : No. 67-9, Shir Men Road, Tu Cheng City, Taipei Hsien,
Taiwan, R. O. C.
TEL / FAX : +886-2-22608375 / +886-2-22748013
E-mail : hometek@ms15.hinet.net
Standard : EN 55022 Class B (1998) + A1 (2000) + A2 (2003),
EN 61000-3-2 (2000), EN 61000-3-3 (1995) + A1 (2001),
EN 55024 (1998) + A1 (2001) + A2 (2003):
IEC 61000-4-2 (2001), IEC 61000-4-3 (2002),
IEC 61000-4-4 (2004), IEC 61000-4-5 (2001),
IEC 61000-4-6 (2003) + A1 (2004), IEC 61000-4-8 (2001),
IEC 61000-4-11 (2004)

Tested by (+ signature) :

Jason Lin / Engineer



Approved by (+ signature) :

Alain Lin / Assistant Manager





TEST REPORT CERTIFICATION..... 1

TABLE OF CONTENTS..... 2

GENERAL INFORMATION..... 5

MODIFICATION LIST..... 6

CONDUCTED POWER LINE TEST 7

1 TEST INSTRUMENTS & FACILITIES..... 7

2 TEST PROCEDURE..... 7

3 TEST SETUP 8

4 CONFIGURATION OF THE EUT 10

5 EUT OPERATING CONDITION..... 18

6 LIMIT OF CONDUCTED POWER LINE EMISSION CLASS B..... 19

7 RESULT OF CONDUCTED POWER LINE TEST..... 19

8 CONDUCTED POWER LINE TEST DATA (PAGE 1)..... 20

9 CONDUCTED POWER LINE TEST DATA (PAGE 2)..... 21

10 CONDUCTED POWER LINE TEST DATA (PAGE 3)..... 22

11 CONDUCTED POWER LINE TEST DATA (PAGE 4)..... 23

RADIATED EMISSION TEST..... 24

1 TEST INSTRUMENTS & FACILITIES..... 24

2 TEST PROCEDURE..... 25

3 TEST SETUP 25

4 CONFIGURATION OF THE EUT 27

5 EUT OPERATING CONDITION..... 27

6 LIMIT OF RADIATED EMISSION CLASS B 27

7 RESULT OF RADIATED EMISSION TEST..... 27

8 RADIATED EMISSION TEST DATA (PAGE 1)..... 28

9 RADIATED EMISSION TEST DATA (PAGE 2)..... 29

HARMONICS TEST..... 30

1 TEST INSTRUMENTS & FACILITIES..... 30

2 TEST PROCEDURE..... 30

3 TEST SETUP 30

4 CONFIGURATION OF THE EUT 30

5 OPERATION CONDITION OF EUT..... 30

6 TEST DATA & LIMIT..... 30

7 PHOTOS OF TEST CONFIGURATION PLEASE REFER TO APPENDIX A..... 30

8 HARMONICS TEST DATA (PAGE 1~2)..... 31

VOLTAGE FLUCTUATIONS TEST 33

1 TEST INSTRUMENTS & FACILITIES..... 33

2 TEST PROCEDURE..... 33



3 TEST SETUP 33

4 CONFIGURATION OF THE EUT 33

5 OPERATION CONDITION OF EUT 33

6 TEST DATA & LIMIT 33

7 PHOTOS OF TEST CONFIGURATION PLEASE REFER TO APPENDIX A 33

8 VOLTAGE FLUCTUATIONS TEST DATA (PAGE 1) 34

ELECTROSTATIC DISCHARGE IMMUNITY TEST (ESD) 35

1 TEST INSTRUMENTS & FACILITIES 35

2 TEST PROCEDURE 35

3 TEST SETUP 35

4 CONFIGURATION OF THE EUT 36

5 EUT OPERATION CONDITION 36

6 TEST CONDITION 36

7 PERFORMANCE CRITERIA 36

8 TEST RESULT 37

RADIO FREQUENCY ELECTROMAGNETIC FIELD IMMUNITY TEST (RF) 38

1 TEST INSTRUMENTS & FACILITIES 38

2 TEST PROCEDURE 38

3 TEST SETUP 39

4 CONFIGURATION OF THE EUT 40

5 OPERATION CONDITION OF EUT 40

6 TEST CONDITION 40

7 PERFORMANCE CRITERIA 40

8 TEST RESULT 41

ELECTRICAL FAST TRANSIENT/BURST IMMUNITY TEST (EFT) 42

1 TEST INSTRUMENTS & FACILITIES 42

2 TEST PROCEDURE 42

3 TEST SETUP 42

4 CONFIGURATION OF THE EUT 43

5 OPERATION CONDITION OF EUT 43

6 TEST CONDITION 43

7 PERFORMANCE CRITERIA 43

8 TEST RESULT 44

SURGE IMMUNITY TEST 45

1 TEST INSTRUMENTS & FACILITIES 45

2 TEST PROCEDURE 45

3 TEST SETUP 45

4 TEST LEVELS 46

5 CONFIGURATION OF THE EUT 46



6 EUT OPERATION CONDITION..... 46

7 CONDITIONS DURING TESTING..... 46

8 PERFORMANCE CRITERIA 47

9 TEST RESULT 47

IMMUNITY TEST TO CS CONDUCTED DISTURBANCE 48

1 TEST INSTRUMENTS & FACILITIES..... 48

2 TEST PROCEDURE..... 48

3 TEST SETUP 49

4 TEST LEVELS..... 50

5 CONFIGURATION OF THE EUT 50

6 EUT OPERATION CONDITION..... 50

7 CONDITIONS DURING TESTING..... 50

8 PERFORMANCE CRITERIA 51

9 TEST RESULT 51

POWER FREQUENCY MAGNETIC FIELD IMMUNITY TEST 52

1 TEST INSTRUMENTS & FACILITIES..... 52

2 TEST STANDARD..... 52

3 TEST SETUP 52

4 TEST LEVELS..... 53

5 CONFIGURATION OF THE EUT 53

6 OPERATION CONDITION OF EUT..... 53

7 CONDITIONS DURING TESTING..... 53

8 PERFORMANCE CRITERIA 53

9 TEST RESULTS 54

VOLTAGE DIPS, SHORT INTERRUPTIONS IMMUNITY TEST..... 55

1 TEST INSTRUMENTS & FACILITIES..... 55

2 TEST PROCEDURE..... 55

3 TEST SETUP 55

4 TEST LEVELS..... 56

5 CONFIGURATION OF THE EUT 56

6 EUT OPERATION CONDITION..... 56

7 CONDITIONS DURING TESTING..... 56

8 PERFORMANCE CRITERIA 57

9 TEST RESULT 57

APPENDIX A

PHOTOS OF TEST CONFIGURATION

APPENDIX B

PHOTOS OF EUT

GENERAL INFORMATION

- 1 APPLICANT : Smart Home Engineering Corp.
- 2 ADDRESS : 10F., No. 493, Chung-Cheng Rd.,
Hsin-Tien City, Taipei 231, Taiwan, R. O. C.
- 3 MANUFACTURER : Smart Home Engineering Corp.
- 4 ADDRESS : 10F., No. 493, Chung-Cheng Rd.,
Hsin-Tien City, Taipei 231, Taiwan, R. O. C.
- 5 DESCRIPTION OF EUT :
- EUT : USB CAT5 extender with 4 port USB hub
- Model : UE0XXX
- Serial # : N/A

5.1 The difference between series of models UE0XXX are as shown below:

- (1) The first and second “X” represents different system input.
- (2) The third “X” represent different accessory.

The PCB layout is similar. The worst case of EMC test data were shown in this test report.

- 6 FEATURES OF EUT :

Please refer to user manual or product specification.

MODIFICATION LIST

THE FOLLOWING ACCESSORIES WERE ADDED TO THE EUT DURING TESTING :

NO MODIFICATION BY HOMETEK TECHNOLOGY INC.

CONDUCTED POWER LINE TEST

1 TEST INSTRUMENTS & FACILITIES

The following test Instruments was used during the conducted test :

Item	Instruments/ Facilities	Specification	Manufacturer	Model #	Date Of Cal.
1	EMI Receiver	9KHz ~ 30MHz	ROHDE & SCHWARZ	ESHS 30 844827/007	FEB/2007
2	LISN (for EUT)	50Ω/50uH/100A 150KHz ~ 30MHz	SCHWARZ BECK	NNLK 8121 8121370	OCT/2006
3	LISN (for Support Unit)	50Ω/50uH/10A 9KHz ~ 30MHz	ROHDE & SCHWARZ	ESH3-Z5 846128/007	MAR/2007
4	Terminator	50Ω	N/A	N/A	NOV/2006
5	Attenuation	50Ω/10dB	Mini-Circuit	NAT-10 AT-002	JUL/2006
6	Cable	5.4m	SUHNER	RG-223 CON2-002	AUG/2006
7	ESXS-K1 (software)	Version 2.03b 9KHz ~ 30MHz	ROHDE & SCHWARZ	1082.9678.02 840.913/246	N/A

Note : Items 1 ~ 6 were calibrated within period of 1 year.

2 TEST PROCEDURE

- 2.1 The EUT was tested according to **EN55022 Class B**.
- 2.2 The EUT was placed 0.4 meter from the conducting wall of shielding room and kept at least 0.8 meter from any other grounded conducting surface.
- 2.3 The frequency range form 0.15 MHz to 30 MHz was investigated.
- 2.4 The LISN used was 50 Ohm / 50 uHenry as specified by **EN55022**.
- 2.5 All the support peripherals are connect to the other LISN.
- 2.6 Cables and peripherals were moved to find the maximum emission levels for each frequency.

3 TEST SETUP

3.1 Typical : Setup Of Conducted Test

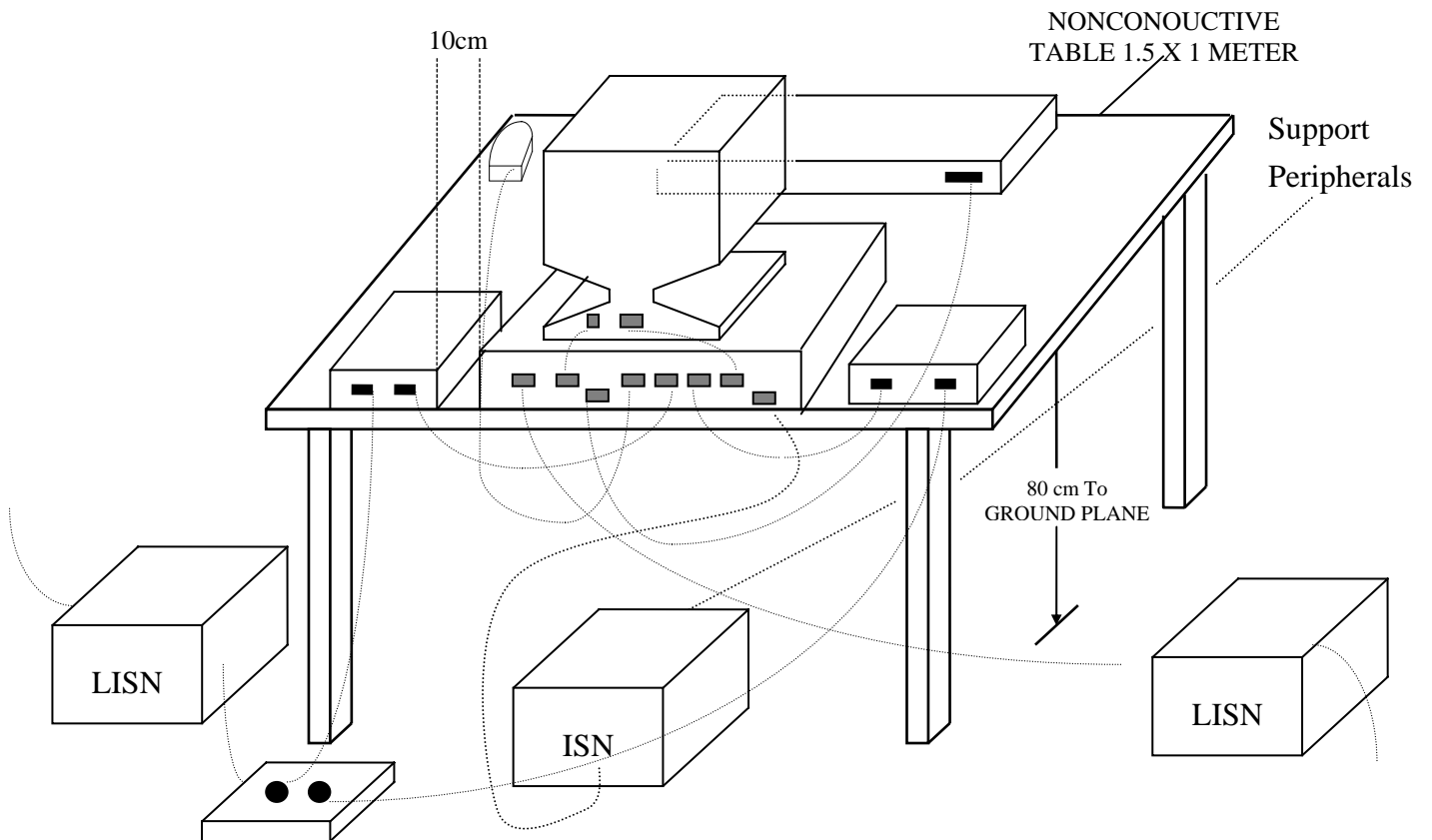

(Details for setup configuration, please refer to appendix A.)

3.2 Block Diagram Of Conducted Test

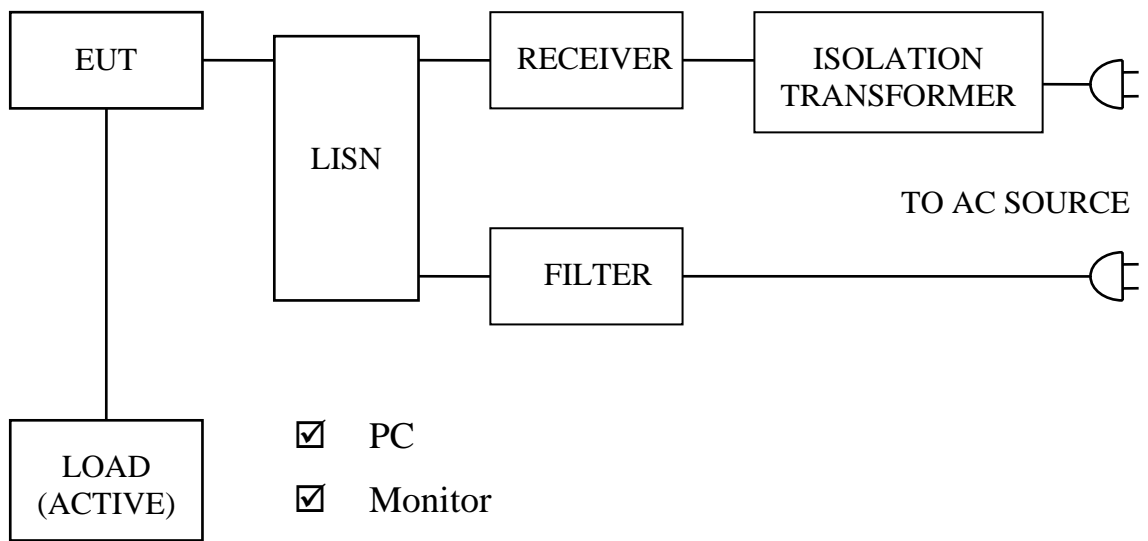

- PC
- Monitor
- Printer
- Modem
- Mouse x 5
- Key Board x 2
- VGA Keyboard Mouse CAT5 Extender x 2 (VKM01)
- Keyboard Mouse CAT5 Extender (KM01T)
- Keyboard Mouse CAT5 Extender (KM01R)

4 CONFIGURATION OF THE EUT

The EUT was configured according to **EN55022**. All I/O ports were connected to the appropriate peripherals. All peripherals and cables are listed below (including internal device) :

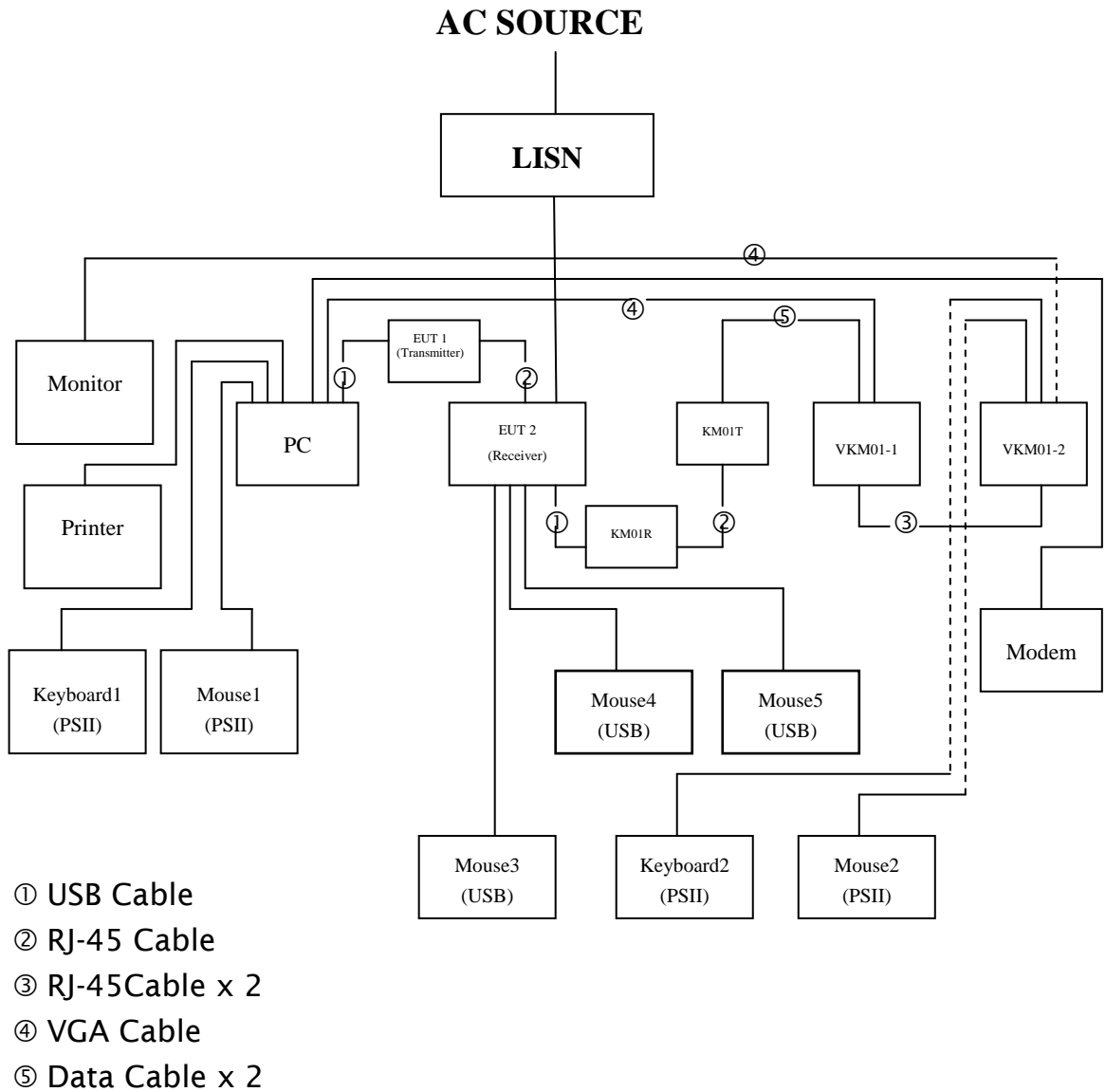

Figure 1



4.1 EUT

EUT Type : Proto Type Engineer Type Mass Production

Condition when received : Good Damage : _____

Device : USB CAT5 extender with 4 port USB hub

Applicant : Smart Home Engineering Corp.

Manufacturer : Smart Home Engineering Corp.

Model Number : UE0XXX

Serial Number : N/A

FCC ID : N/A

● UE01 (Transmitter)

USB Port : Metal Type Connector

RJ-45 Port : Plastic Type Connector

Power Cord : N/A

Power Supply Type : From PC

● UE01 (Receiver)

USB Port x 4 : Metal Type Connector

RJ-45 In Port : Metal Type Connector

Power Cord (AC) : 2 pin

Power Cord (DC) : Un-Shielded, 1.8 m, 2 pin

Power Supply Type : Switching Adapter



4.2 PERIPHERALS

Host Personal Computer

Manufacturer : HP/COMPAQ
Model Number : D330UT
Serial Number : SGH40606Z1
FCC ID : FCC DoC
Data Cable 1 : Un-Shielded, 0.18 m, Connect to the USB Port
Data Cable 2 : Shielded, 1.8 m, Connect to the VGA In Port
Power Cord : Un-Shielded, 1.8 m

VGA Card

Manufacturer : ASUS
Model Number : V9999LE/TD/N/128M/A
Serial Number : 59CG018553
FCC ID : N/A
Data Cable : N/A
Power Cord : N/A

Monitor

Manufacturer : SAMSUNG
Model Number : GH19BS
Serial Number : GH19H4JW103538B
FCC ID : FCC DoC
Data Cable : Shielded, 1.8 m, Connected to the VGA Out port
Power Cord : Un-Shielded, 1.8 m



Printer

Manufacturer : HP
Model Number : DJ400
Serial Number : MY7781C1BB
FCC ID : B94C2642X
Data Cable : Shielded, 1.5 m, Connected to the Printer port
Power Cord & Adaptor : Un-Shielded, 1.8 m

Modem

Manufacturer : ACEEX
Model Number : 1414
Serial Number : 9013524
FCC ID : IFAXDM1414
Data Cable : Shielded, 1.5 m, Connected to the COM port
Power Cord & Adaptor : Un-Shielded, 1.8 m

Mouse1 (PSII)

Manufacturer : DELL
Model Number : IntelliMouse 1.3A PS/2 Compatible
Serial Number : 9028603-5
FCC ID : FCC DoC
Data Cable : Shielded, 1.8 m, Connected to the PSII port
Power Cord : N/A



Mouse2 (PSII)

Manufacturer : Microsoft
Model Number : KAZB1
Serial Number : 0720670
FCC ID : C3KAZB1
Data Cable : Shielded, 1.8 m, Connected to the PSII port
Power Cord : N/A

Mouse3 (USB)

Manufacturer : Genius
Model Number : NetScorII
Serial Number : N/A
FCC ID : N/A
Data Cable : Un-Shielded, 1.8 m, Connected to the USB port
Power Cord : N/A

Mouse4 (USB)

Manufacturer : Memorex
Model Number : MP23R-E
Serial Number : N/A
FCC ID : N/A
Data Cable : Un-Shielded, 1.8 m, Connected to the USB port
Power Cord : N/A



Mouse5 (USB)

Manufacturer : Memorex
Model Number : MP23R-E
Serial Number : N/A
FCC ID : N/A
Data Cable : Un-Shielded, 1.8 m, Connected to the USB port
Power Cord : N/A

KeyBoard1 (PSII)

Manufacturer : Monterey
Model Number : K371
Serial Number : H0007057608
FCC ID : FCC DoC
Data Cable : Shielded, 1.5 m, Connected to the PSII port
Power Cord : N/A

KeyBoard2 (PSII)

Manufacturer : ASUS
Model Number : KS-613P
Serial Number : N/A
FCC ID : N/A
Data Cable : Un-Shielded, 1.5 m, Connected to the PSII port
Power Cord : N/A



VGA Keyboard Mouse CAT5 Extender-1

Manufacturer : Smart Home Engineering Corp.
Model Number : VKM01
Serial Number : N/A
FCC ID : N/A
Data Cable 1 : Un-Shielded, 0.26 m, Connected to the Keyboard port
Data Cable 2 : Un-Shielded, 0.26 m, Connected to the Mouse port
Data Cable 3 : Shielded, 1.8 m, Connected to the VGA In port
Data Cable 4 : Un-Shielded, 1.8 m, Connected to the RJ1 port
Data Cable 5 : Un-Shielded, 1.8 m, Connected to the RJ2 port
Power Cord : N/A

VGA Keyboard Mouse CAT5 Extender-2

Manufacturer : Smart Home Engineering Corp.
Model Number : VKM01
Serial Number : N/A
FCC ID : N/A
Data Cable 1 : Un-Shielded, 1.5 m, Connected to the Keyboard port
Data Cable 2 : Un-Shielded, 1.8 m, Connected to the Mouse port
Data Cable 3 : Shielded, 1.8 m, Connected to the VGA Out port
Data Cable 4 : Un-Shielded, 1.8 m, Connected to the RJ1 port
Data Cable 5 : Un-Shielded, 1.8 m, Connected to the RJ2 port
Power Cord : N/A



Keyboard Mouse CAT5 Extender

Manufacturer : Smart Home Engineering Corp.
Model Number : KM01T
Serial Number : N/A
FCC ID : N/A
Data Cable 1 : Un-Shielded, 0.07 m, Connected to the RJ-45 port
Data Cable 2 : Un-Shielded, 0.26 m, Connected to the Keyboard port
Data Cable 3 : Un-Shielded, 0.26 m, Connected to the Mouse port
Power Cord : N/A

Keyboard Mouse CAT5 Extender

Manufacturer : Smart Home Engineering Corp.
Model Number : KM01R
Serial Number : N/A
FCC ID : N/A
Data Cable 1 : Un-Shielded, 0.18 m, Connected to the USB port
Data Cable 2 : Un-Shielded, 0.07 m, Connected to the RJ-45 In port
Power Cord : N/A

Power Adapter (For Receiver)

Manufacturer : DVE
Model Number : HSWF-0502500E
Serial Number : N/A
FCC ID : N/A
Data Cable : N/A
Power Cord (DC) : Un-Shielded, 1.8 m

4.3 REMARK : N/A

5 EUT OPERATING CONDITION

5.1 The crystal frequencies of the EUT are 12 MHz and 24 MHz x 2.

5.2 Configure the EUT according to the **EN 55022 Class B**.

5.3

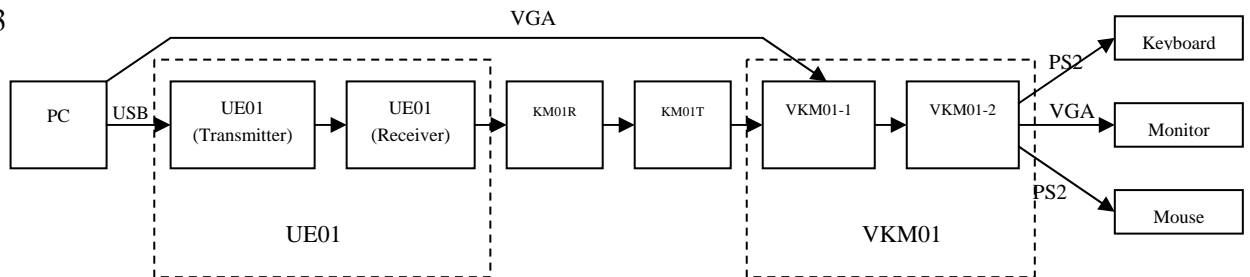

5.4 PC sends VGA signal to VKM01 and VKM01 change VGA signal.

5.5 During the test, the PC sends “H” patterns to each I/O port individually. (For 1280 x 1024)

5.6 Then has changed VGA signal send to monitor display.

5.7 The photos of conducted test configuration, please refer to appendix A.

6 LIMIT OF CONDUCTED POWER LINE EMISSION CLASS B

Frequency Range	Quasi Peak	Average
0.15 ~ 0.5 MHz	66 - 56 dBuV	56 - 46 dBuV
0.5 ~ 5 MHz	56 dBuV	46 dBuV
5 ~ 30 MHz	60 dBuV	50 dBuV

7 RESULT OF CONDUCTED POWER LINE TEST

- 7.1 The frequency range from 0.15 MHz to 30 MHz was investigated. All readings are quasi-peak values and average.
- 7.2 IF bandwidth : 9 kHz, Meas Time : 1 sec.
- 7.3 Temperature : 23 °C, Humidity : 55 % RH.
- 7.4 Deviations from the test standards and rules : None.
- 7.5 The conducted test result were gained by following procedures :
 Level = Reading Level + Insertion Loss of LISN + Cable Loss
 (All calculation were done by ESHS30 EMI test receiver.)
- 7.6 Result : **PASSED**

8 CONDUCTED POWER LINE TEST DATA (PAGE 1)

HomeTek EMC LAB. TEL :886-2-22608375

18 May 2007 16:43

CONDUCTED EMISSIONS

EUT: USB CAT 5 extender with 4 port USB hub
 Manuf: 6E022
 Op Cond: LINE 1
 Operator: LIAO
 Test Spec: FOR EN55022 CLASS B
 Comment: 230V/50Hz
 UE01 (PC LINK MODE)

Result File:

Prescan Measurement: Detectors: X PK / + AV
 Meas Time: see scan settings
 Subranges: 16
 Acc Margin: 55 dB

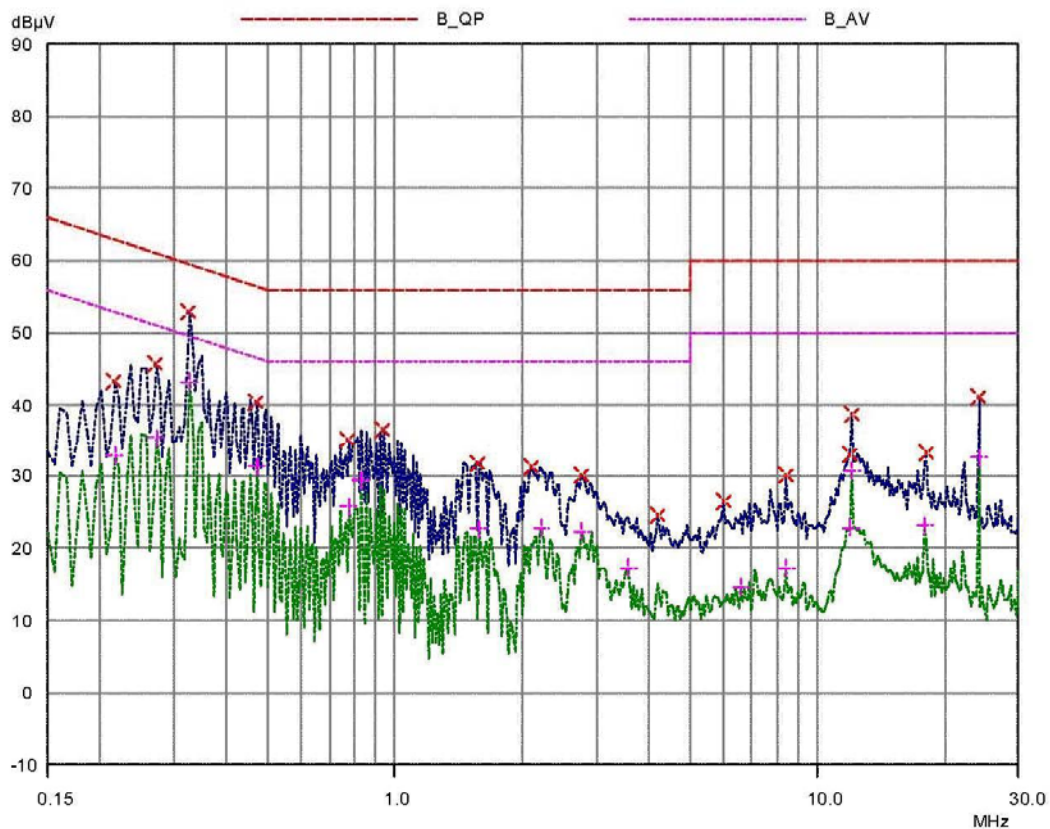



9 CONDUCTED POWER LINE TEST DATA (PAGE 2)

HomeTek EMC LAB. TEL :886-2-22608375

18 May 2007 16:43

CONDUCTED EMISSIONS

EUT: USB CAT 5 extender with 4 port USB hub
 Manuf: 6E022
 Op Cond: LINE 1
 Operator: LIAO
 Test Spec: FOR EN55022 CLASS B
 Comment: 230V/50Hz
 UE01 (PC LINK MODE)

Result File:

Prescan Measurement: Detectors: X PK / + AV
 Meas Time: see scan settings
 Subranges: 16
 Acc Margin: 55 dB

Peak Search Results

Frequency MHz	PK Level dBµV	PK Limit dBµV	PK Delta dB
0.215	43.26	63.01	19.75
0.27	45.70	61.12	15.42
0.325	53.01	59.58	6.57
0.47	40.48	56.51	16.03
0.775	35.07	56.00	20.93
0.94	36.63	56.00	19.37
1.57	31.80	56.00	24.20
2.08998	31.18	56.00	24.82
2.76	30.09	56.00	25.91
4.19	24.48	56.00	31.52
5.97	26.52	60.00	33.48
8.38	30.05	60.00	29.95
11.96	33.05	60.00	26.95
12.0	38.74	60.00	21.26
18.0	33.31	60.00	26.69
24.0	41.04	60.00	18.96

Frequency MHz	AV Level dBµV	AV Limit dBµV	AV Delta dB
0.215	32.93	53.01	20.08
0.27	35.44	51.12	15.68
0.325	43.26	49.58	6.32
0.47	31.35	46.51	15.16
0.775	25.77	46.00	20.23
0.83	29.47	46.00	16.53
1.57	22.70	46.00	23.30
2.22	22.78	46.00	23.22
2.76	22.35	46.00	23.65
3.54	17.30	46.00	28.70
6.58	14.68	50.00	35.32
8.38	17.34	50.00	32.66
11.96	22.84	50.00	27.16
12.0	30.79	50.00	19.21
17.91	23.17	50.00	26.83
24.0	32.49	50.00	17.51

* limit exceeded

10 CONDUCTED POWER LINE TEST DATA (PAGE 3)

HomeTek EMC LAB. TEL :886-2-22608375

18 May 2007 16:50

CONDUCTED EMISSIONS

EUT: USB CAT5 extender with 4 port USB hub
 Manuf: 6E022
 Op Cond: LINE 2
 Operator: LIAO
 Test Spec: FOR EN55022 CLASS B
 Comment: 230V/50Hz
 UE01 (PC LINK MODE)

Result File:

Prescan Measurement: Detectors: X PK / + AV
 Meas Time: see scan settings
 Subranges: 16
 Acc Margin: 55 dB

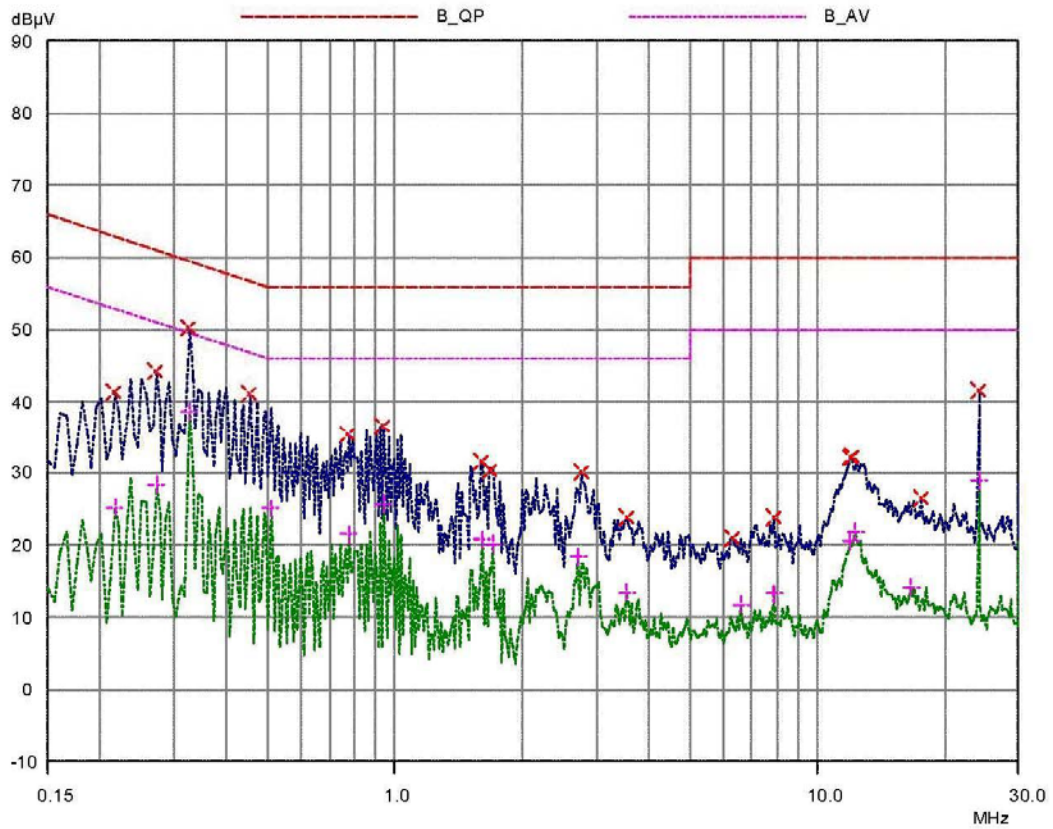



11 CONDUCTED POWER LINE TEST DATA (PAGE 4)

HomeTek EMC LAB. TEL :886-2-22608375

18 May 2007 16:50

CONDUCTED EMISSIONS

EUT: USB CAT 5 extender with 4 port USB hub
 Manuf: 6E022
 Op Cond: LINE 2
 Operator: LIAO
 Test Spec: FOR EN55022 CLASS B
 Comment: 230V/50Hz
 UE01 (PC LINK MODE)

Result File:

Prescan Measurement: Detectors: X PK / + AV
 Meas Time: see scan settings
 Subranges: 16
 Acc Margin: 55 dB

Peak Search Results

Frequency MHz	PK Level dBµV	PK Limit dBµV	PK Delta dB
0.215	41.33	63.01	21.68
0.27	44.17	61.12	16.95
0.325	50.19	59.58	9.39
0.45	41.03	56.88	15.85
0.775	35.30	56.00	20.70
0.94	36.55	56.00	19.45
1.61	31.50	56.00	24.50
1.68	30.36	56.00	25.64
2.76	30.06	56.00	25.94
3.52	23.76	56.00	32.24
6.28	21.02	60.00	38.98
7.84	23.78	60.00	36.22
11.9	32.13	60.00	27.87
12.09	32.19	60.00	27.81
17.63	26.56	60.00	33.44
24.0	41.60	60.00	18.40

Frequency MHz	AV Level dBµV	AV Limit dBµV	AV Delta dB
0.215	25.18	53.01	27.83
0.27	28.40	51.12	22.72
0.325	38.66	49.58	10.92
0.505	25.14	46.00	20.86
0.775	21.52	46.00	24.48
0.94	25.73	46.00	20.27
1.61	20.75	46.00	25.25
1.7	20.15	46.00	25.85
2.69	18.32	46.00	27.68
3.52	13.43	46.00	32.57
6.58	11.81	50.00	38.19
7.84	13.31	50.00	36.69
11.87	20.50	50.00	29.50
12.32	21.91	50.00	28.09
16.67	14.18	50.00	35.82
24.01	28.97	50.00	21.03

* limit exceeded

RADIATED EMISSION TEST

1 TEST INSTRUMENTS & FACILITIES

The following test Instruments was used during the radiated emission test :

Item	Instruments /facilities	Specification	Manufacturer	Model # / S/N#	Date of Cal.
1	OPEN AREA TEST SITE	<input checked="" type="checkbox"/> OATS 3			JUL/2006
2	EMI TEST RECEIVER	20Hz ~ 26.5GHz	ROHDE & SCHWARZ	ESMI 845442/006	FEB/2007
3	PRE-AMPLIFIER	9KHz ~ 3000MHz	ADVANTEST	BB525C 90081001	OCT/2006
4	ANTENNA (BI-LOG)	25MHz ~ 2GHz	SCHAFFNER	CBL6112B S/N : 2614	JUN/2006
5	Attenuation	50Ω/6dB	JYE BAO	FAT-N (M-F) 001	JUL/2006
6	Ferrite Clamp	30 ~ 1000MHz	ADT	FC18 910030	DEC/2006
7	Ferrite Clamp	30 ~ 1000MHz	HomeTek	HFC 001	DEC/2006
8	Cable	10m	SUHNER	RG214/U OS3-003	DEC/2006
9	Cable	14m	BELDEN	9913 OS3-001	DEC/2006
10	EMI 32 (software)	N/A	AUDIX	19991013-0923	N/A

Note : Items 1 ~ 9 were calibrated within period of 1 year.

2 TEST PROCEDURE

- 2.1 The EUT was test according to **EN55022**.
- 2.2 The radiated test was performed at HomeTek Lab's Open Site 3.
- 2.3 The frequency range from 30 MHz to 1 GHz, the measurement were made at 10 meters, with a BI-log antenna.

3 TEST SETUP

3.1 TEST SETUP OF OPEN SITE.

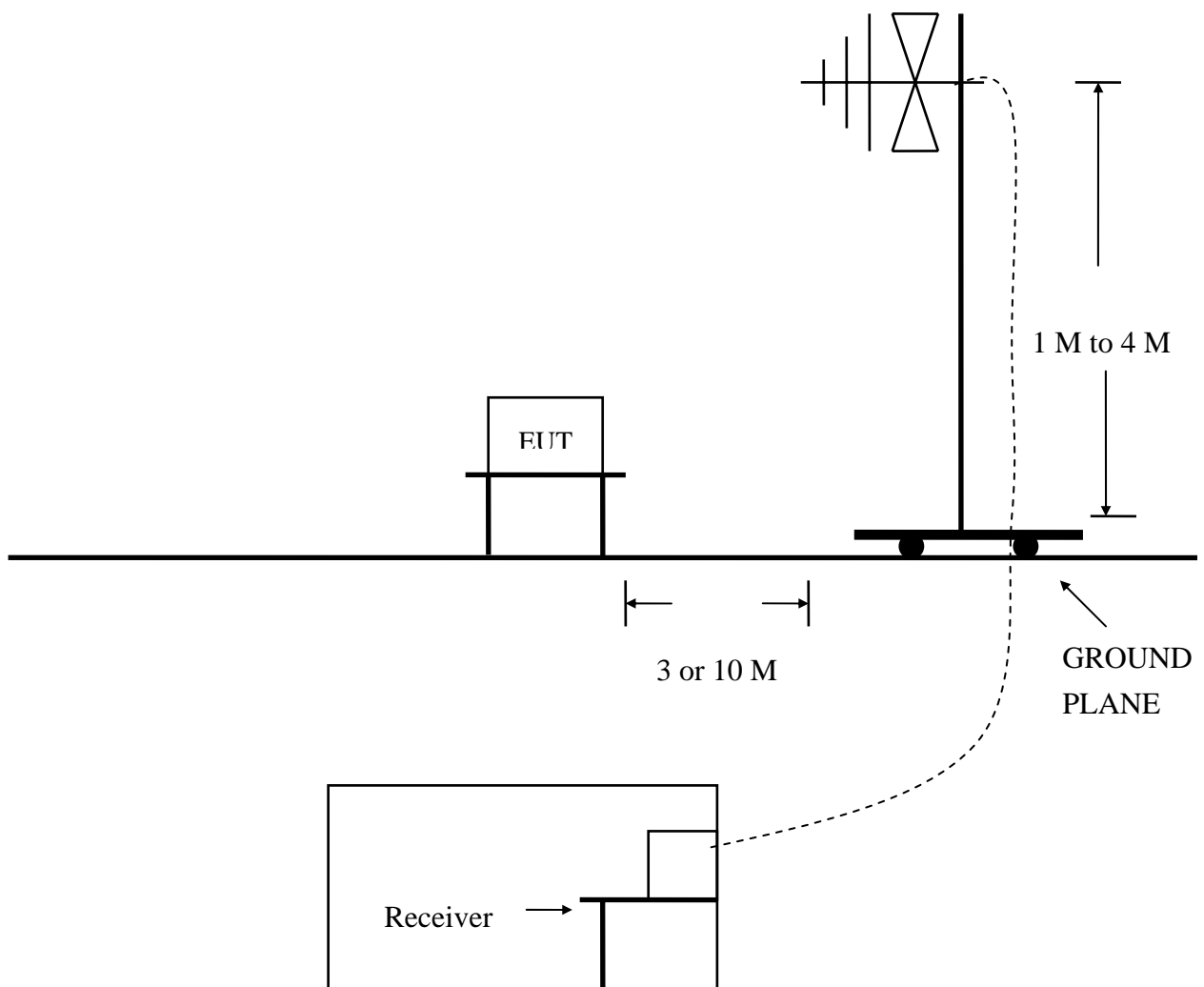

(Details for setup configuration, please refer to appendix A.)

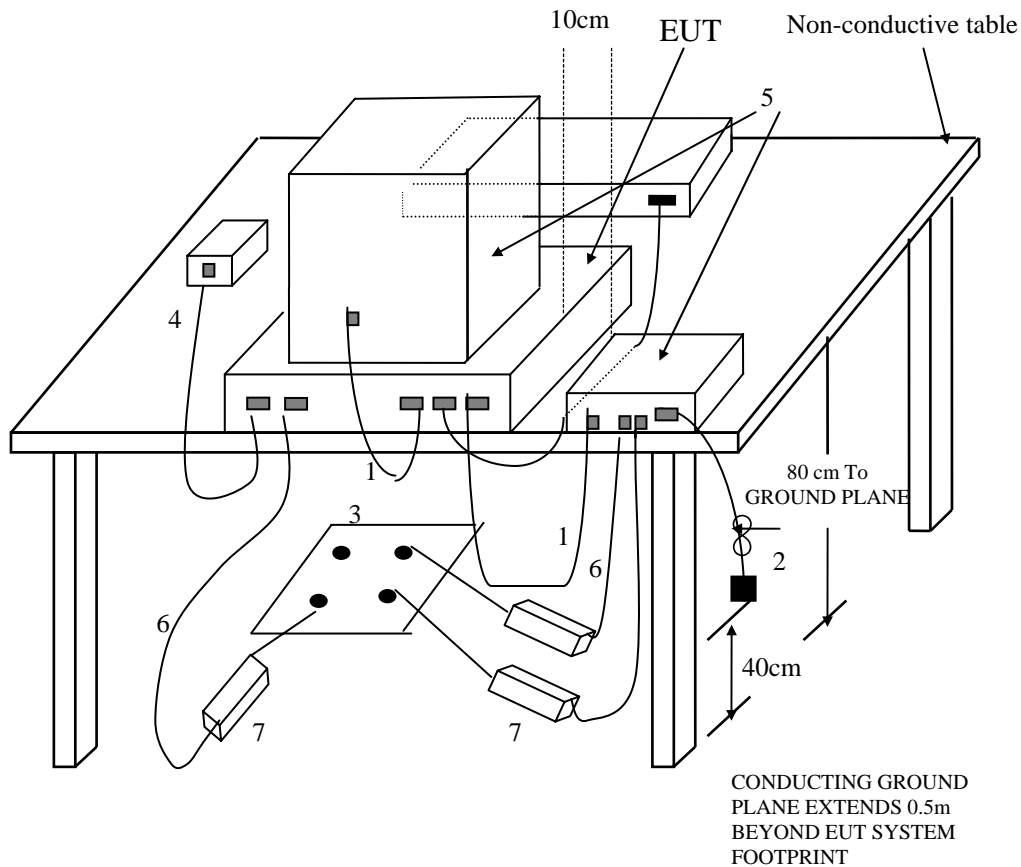

(Details for setup configuration, please refer to appendix A.)

LEGEND:

- 1.If cables, which hang closer than 40 cm to the horizontal metal ground plane cannot be shortened to the appropriate length, the excess shall be folded back and forth forming a bundle 30 cm to 40 cm long.
- 2.The end of I/O signal cables which are not connected to a peripheral may be terminated, if required for proper operation using correct terminating impedance.
- 3.Mains junction box(es) shall be flush with, and bonded directly to, the metal ground plane.
NOTE if used, the AMN shall be installed under the horizontal metal ground plane.
- 4.Cables of hand-operated devices such as keyboards, mice, etc. shall be placed as for normal usage.
- 5.Peripherals shall be placed at a distance of 10 cm from each other and from the controller, except for the monitor which, if for an acceptable installation practice, shall be placed directly on top of the controller.
- 6.Mains cables, telephone lines or other connections to auxiliary equipment located outside the test area shall drape to the floor, be fitted with ferrite clamps or ferrite tubes placed on the floor at the point where the cable reaches the floor and then routed to the place where they leave the turntable. No extension cords shall be used to mains receptacle.
- 7.Ferrite clamps or ferrite tubes with similar characteristics (as defined in 10.4). No more than one cable per clamp.

Test Configuration
Tabletop Equipment Radiated Measurement

4 CONFIGURATION OF THE EUT

Same as “Conducted Power Line test”, section 4

5 EUT OPERATING CONDITION

5.1 Same as “Conducted Power Line test”, section 5

5.2 The radiated emission in the frequency range from 30 MHz - 1000 MHz was test in a horizontal and vertical polarization at HomeTek Lab’s open site 3.

5.3 The photos of radiated test configuration, please refer to appendix A.

6 LIMIT OF RADIATED EMISSION CLASS B

Frequency (MHz)	Measurement Distance	Limit (dBuV/m)
30 - 230	10 (M)	30
230 - 1000	10 (M)	37

7 RESULT OF RADIATED EMISSION TEST

7.1 The frequency range from 30 MHz to 1 GHz was investigated.

7.2 All readings below or equal 1 GHz are quasi-peak or peak values with resolution bandwidth of 120 KHz.

7.3 The measurements were made at 10 meters of HomeTek Lab’s open site 3.

7.4 Temperature : 25 °C, Humidity : 49 % RH.

7.5 Deviation form the test standards and rules : None.

7.6 The radiated emission result were gained by the following method :

$$\text{Level} = \text{Reading Level} + \text{Probe Factor (Antenna Factor)} + \text{Cable Loss} - \text{Preamp Factor}$$

$$\text{Over Limit} = \text{Level} - \text{Limit Line}$$

7.7 Result : **PASSED**

8 RADIATED EMISSION TEST DATA (PAGE 1)



HomeTek Technology Inc.

No 67-9, Shi-Men Rd., Tu-Chen City,
 Taipei County, Taiwan R.O.C.
 Tel: 02-22608375
 Fax: 02-22748013

Data#: 6 File#: 6e022.EMI

Date: 2007-05-31 Time: 09:59:28

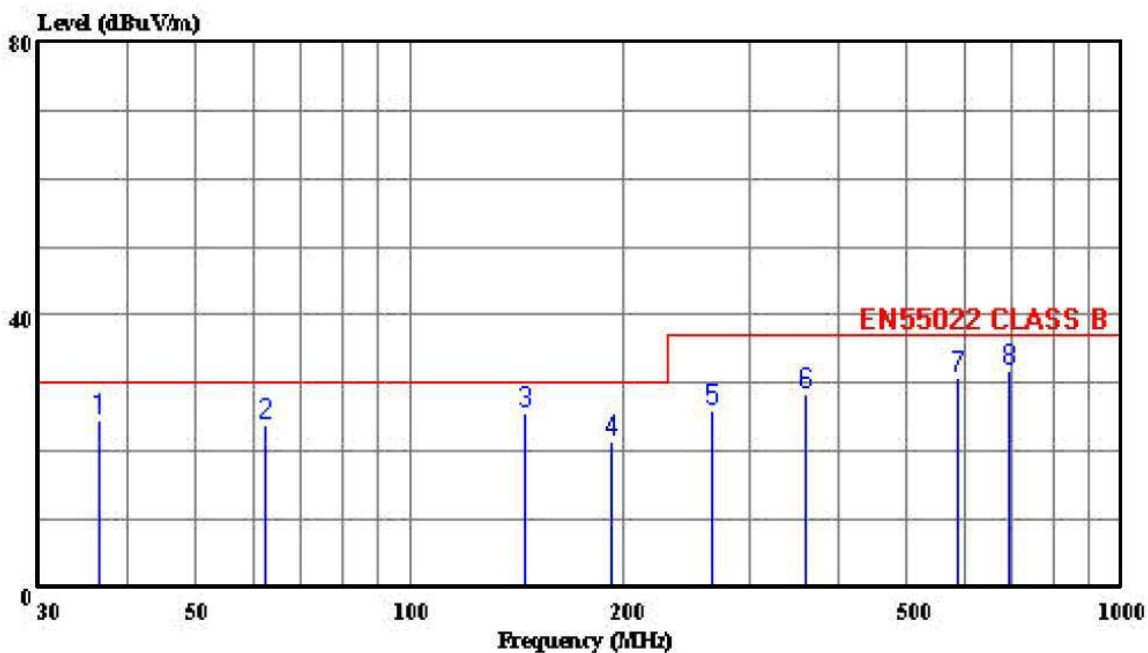

Trace:

Ref Trace:

Condition: EN55022 CLASS B 10m CHASE 2614 060506 HORIZONTAL
 eut : USB CAT5 extender with 4 port USB hub
 power: 230V/50Hz & FROM PC
 memo : UE01

Page: 1

	Freq	Level	Limit	Over	ReadAntenna	Cable	Preamp	Remark
	MHz	dBuV/m	dBuV/m	dB	Level	Loss	Factor	
					Factor			
					dB/m	dB	dB	
1	36.540	24.62	30.00	-5.38	34.00	15.94	0.68	26.00 Peak
2	62.540	23.79	30.00	-6.21	42.00	6.76	0.98	25.95 Peak
3	145.230	25.68	30.00	-4.32	39.00	10.68	1.81	25.81 Peak
4	192.500	21.32	30.00	-8.68	36.00	8.97	2.07	25.72 Peak
5	265.300	26.12	37.00	-10.88	36.00	13.12	2.57	25.57 Peak
6	360.490	28.49	37.00	-8.51	36.00	14.68	3.14	25.33 Peak
7	589.120	30.74	37.00	-6.26	31.00	18.54	5.71	24.51 Peak
8	697.530	31.91	37.00	-5.09	32.00	18.82	5.15	24.05 Peak

9 RADIATED EMISSION TEST DATA (PAGE 2)



HomeTek Technology Inc.

No 67-9, Shi-Men Rd., Tu-Chen City,
 Taipei County, Taiwan R.O.C.
 Tel: 02-22608375
 Fax: 02-22748013

Data#: 5 File#: 6e022.EMI

Date: 2007-05-31 Time: 09:26:18

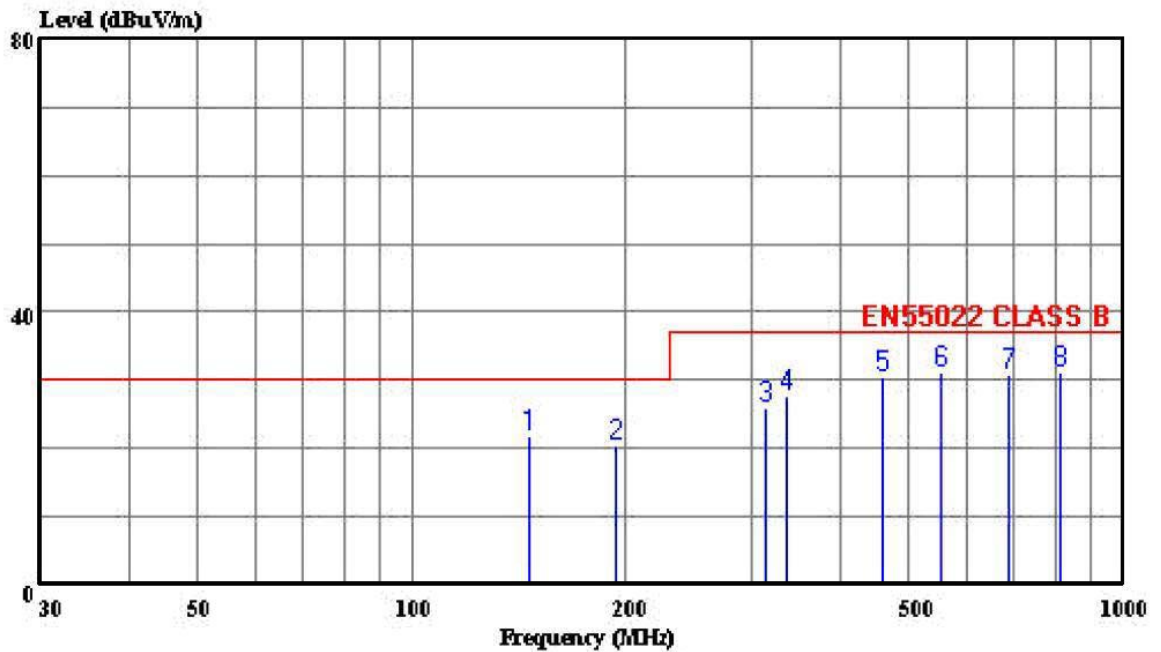

Trace:

Ref Trace:

Condition: EN55022 CLASS B 10m CHASE 2614 060506 VERTICAL
 eut : USB CAT5 extender with 4 port USB hub
 power: 230V/50Hz & FROM PC
 memo : UE01

Page: 1

	Limit	Over	ReadAntenna	Cable	Preamp				
Freq	Level	Line	Limit	Level	Factor	Loss			
MHz	dBuV/m	dBuV/m	dB	dBuV	dB/m	dB			
1	145.600	21.68	30.00	-8.32	35.00	10.68	1.81	25.81	Peak
2	193.800	20.35	30.00	-9.65	35.00	8.99	2.08	25.72	Peak
3	314.500	25.89	37.00	-11.11	35.00	13.49	2.86	25.46	Peak
4	337.200	27.69	37.00	-9.31	36.00	14.09	3.00	25.39	Peak
5	458.120	30.42	37.00	-6.58	35.00	16.72	3.69	24.99	Peak
6	552.120	31.05	37.00	-5.95	32.00	18.69	4.99	24.63	Peak
7	690.100	30.95	37.00	-6.05	31.00	18.84	5.19	24.08	Peak
8	816.500	31.28	37.00	-5.72	30.00	19.89	5.11	23.72	Peak

HARMONICS TEST

1 TEST INSTRUMENTS & FACILITIES

Instruments/ facilities	Manufacturer	Model # Serial #	Date of Cal.
HARMONICS/ VOLTAGE FLUCTUATIONS TEST	EMC-PARTNER	HAR1000-1P	NOV/2006
CONTROL PC	KB TECH	KB P586/133	N/A

Note : Item 1 were calibrated with two years and verified before testing.

2 TEST PROCEDURE

According to EN 61000-3-2 (2000) Class A

3 TEST SETUP

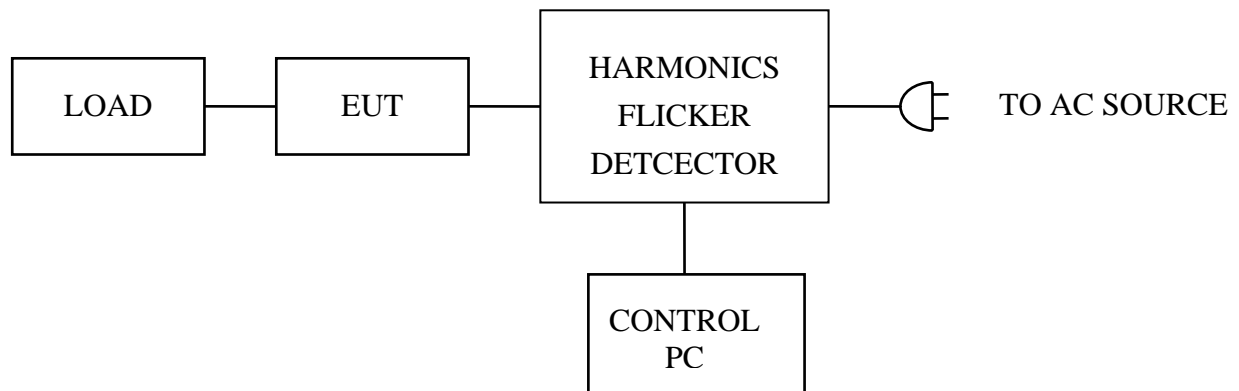

(Details for setup configuration, please refer to appendix A.)

4 CONFIGURATION OF THE EUT

Same as “Conducted Power Line test”, section 4

5 OPERATION CONDITION OF EUT

Same as “Conducted Power Line test”, section 5

6 TEST DATA & LIMIT

6.1 Temperature : 24 °C

6.2 Humidity : 54 % RH

7 Photos of test configuration please refer to appendix A.



8 HARMONICS TEST DATA (PAGE 1~2)

EMC PARTNER AG, SWITZERLAND

Date : 2007/5/31 PM 01:30:51 V4.14

Operator : chad
 Unit : USB CAT5 extender with 4 port USB hub
 Serialnumber : UE01 (ADAPTER)
 Remarks : 6K038

Urms = 229.9V Freq = 49.987 Range: 0.25 A
 Irms = 0.042A Ipk = 0.090A cf = 2.130
 P = 3.503W S = 9.683VA pf = 0.362
 THDi = 42.4 % THDu = 0.10 % Class A

Test - Time : 15min (100 %)

Test completed, Result: PASSED

Order	Freq. [Hz]	Imax [A]	Imax%L [%]	Limit [A]	Status
1	50	0.0696			
2	100	0.0003	0.0240	1.0800	
3	150	0.0158	0.6853	2.3000	
4	200	0.0001	0.0319	0.4300	
5	250	0.0085	0.7469	1.1400	
6	300	0.0000	0.0102	0.3000	
7	350	0.0004	0.0495	0.7700	
8	400	0.0000	0.0066	0.2300	
9	450	0.0012	0.3052	0.4000	
10	500	0.0000	0.0000	0.1840	
11	550	0.0003	0.1017	0.3300	
12	600	0.0000	0.0000	0.1533	
13	650	0.0004	0.1817	0.2100	
14	700	0.0000	0.0000	0.1314	
15	750	0.0003	0.1729	0.1500	
16	800	0.0000	0.0000	0.1150	
17	850	0.0001	0.0807	0.1324	
18	900	0.0000	0.0000	0.1022	
19	950	0.0001	0.1031	0.1184	
20	10000	0.0000	0.0000	0.0920	
21	10500	0.0001	0.1139	0.1071	
22	11000	0.0000	0.0000	0.0836	
23	11500	0.0001	0.0780	0.0978	
24	12000	0.0000	0.0000	0.0767	
25	12500	0.0001	0.0678	0.0900	



HomeTek Technology Inc.

26	13000.0000	0.0000	0.0708
27	13500.0001	0.0732	0.0833
28	14000.0000	0.0000	0.0657
29	14500.0000	0.0590	0.0776
30	15000.0000	0.0000	0.0613
31	15500.0000	0.0420	0.0726
32	16000.0000	0.0000	0.0575
33	16500.0000	0.0448	0.0682
34	17000.0000	0.0000	0.0541
35	17500.0000	0.0475	0.0643
36	18000.0000	0.0000	0.0511
37	18500.0000	0.0502	0.0608
38	19000.0000	0.0000	0.0484
39	19500.0000	0.0264	0.0577
40	20000.0000	0.0000	0.0460

Important:

- without "1000-4-7 Ed. 2" (DFT-window is 16 periods)

VOLTAGE FLUCTUATIONS TEST

1 TEST INSTRUMENTS & FACILITIES

Instruments/ facilities	Manufacturer	Model # Serial #	Date of Cal.
HARMONICS/ VOLTAGE FLUCTUATIONS TEST	EMC-PARTNER	HAR1000-1P	NOV/2006
CONTROL PC	KB TECH	KB P586/133	N/A

Note : Item 1 were calibrated with two years and verified before testing.

2 TEST PROCEDURE

According to **EN 61000-3-3 (1995) + A1 (2001)**

3 TEST SETUP

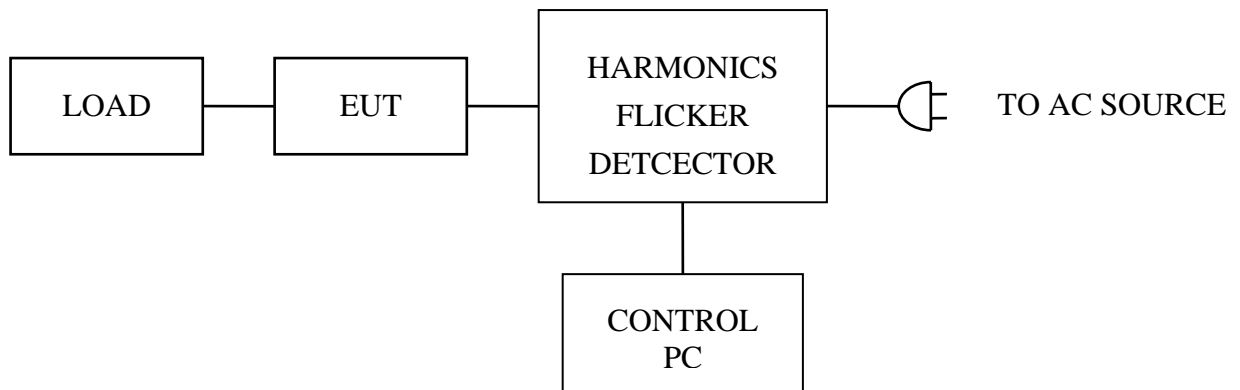

(Details for setup configuration, please refer to appendix A.)

4 CONFIGURATION OF THE EUT

Same as “Conducted Power Line test”, section 4

5 OPERATION CONDITION OF EUT

Same as “Conducted Power Line test”, section 5

6 TEST DATA & LIMIT

6.1 Temperature : 24 °C

6.2 Humidity : 54 % RH

7 Photos of test configuration please refer to appendix A.



8 VOLTAGE FLUCTUATIONS TEST DATA (PAGE 1)

EMC PARTNER AG, SWITZERLAND

Date : 2007/5/31 PM 01:48:41 V4.14

Operator : CHAD
 Unit : USB CAT5 extender with 4 port USB hub
 Serialnumber : UE01 (ADAPTER)
 Remarks : 6K038

Urms = 109.9V Freq = 59.981 Range: 0.25 A
 Irms = 0.029A Ipk = 0.047A cf = 1.621
 P = 1.963W S = 3.221VA pf = 0.610

Test - Time : 1 x 15min = 15min (100 %)

LIN (Line Impedance Network) : L: 0.24ohm +j0.15ohm N: 0.16ohm +j0.10ohm

Limits :Plt : 0.65Pst : 1.00
 dmax : 4.00 % dc : 3.30 %
 dtLim: 3.30 % dt>Lim: 500ms

Test completed, Result: PASSED

Plt = 0.072

Pst dmax
 [%]
 1 0.072 0.000

ELECTROSTATIC DISCHARGE IMMUNITY TEST (ESD)

1 TEST INSTRUMENTS & FACILITIES

Instruments/ Facilities	Manufacturer	Model # Serial #	Data Of Cal.
ESD TESTER	HAEFELY	PESD 1610	NOV/2006
VCP	HOMETEK	--	--

2 TEST PROCEDURE

According to **IEC 61000-4-2 (2001)**

According to **EN 55024 (1998) + A1 (2001) + A2 (2003)**

3 TEST SETUP

TABLE SIZE

160L X 80W X 80H cm

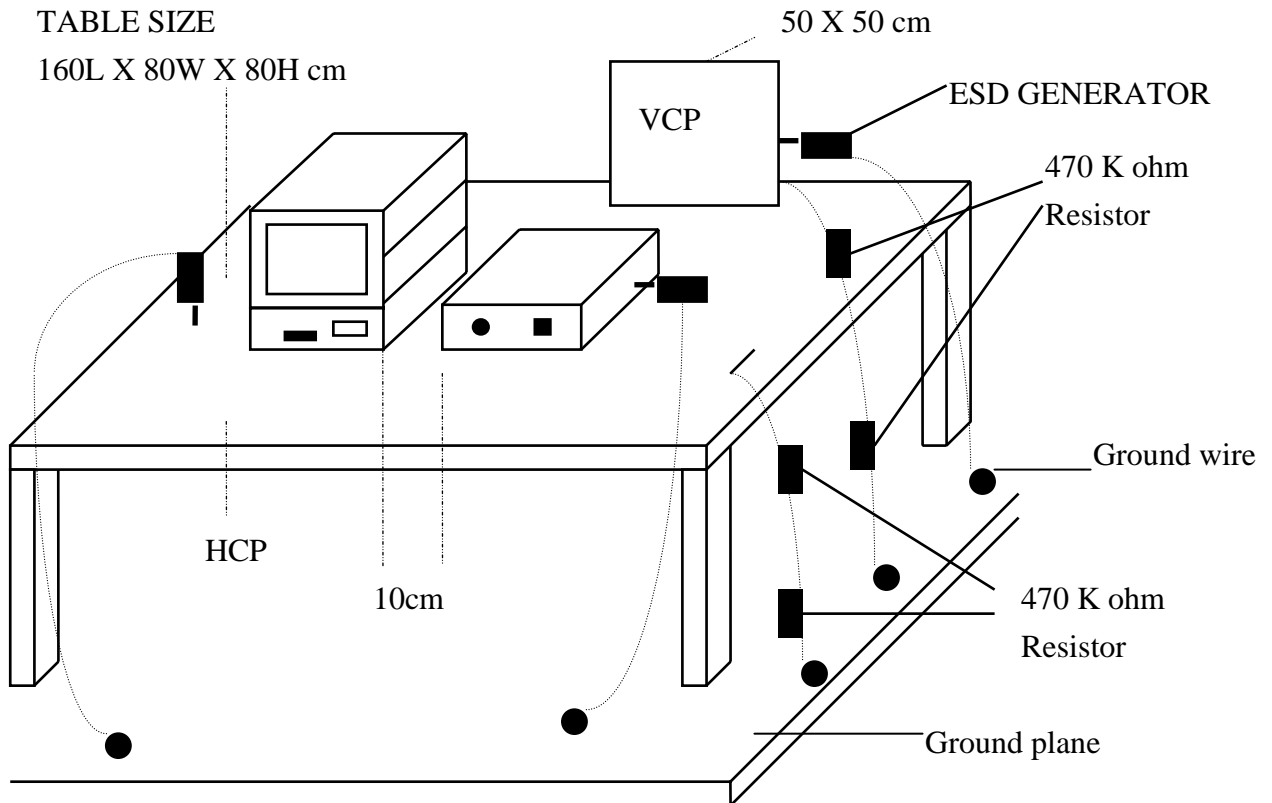

(Details for setup configuration, please refer to appendix A.)

4 CONFIGURATION OF THE EUT

Same as “Conducted Power Line test”, section 4

5 EUT OPERATION CONDITION

Same as “Conducted Power Line test”, section 5

6 TEST CONDITION

6.1 Test Level :

(A) ± 2 , ± 4 , ± 8 KV for air discharge.

(B) ± 2 , ± 4 KV for contact discharge.

6.2 Number of test : 10 Discharges / Test point / Polarity / Level

Particular requirements : at least 200 discharges, 100 each at negative and positive polarity, at a minimum of four test points.

6.3 Time between test : 1 sec.

6.4 Temperature : 21 °C

6.5 Humidity : 45 % RH.

7 PERFORMANCE CRITERIA

- A. The apparatus shall continue to operate as intended during and after the test. No degradation of performance or loss of function is allowed below a performance level specified by the manufacturer, when the apparatus is used as intended.
- B. The apparatus shall continue to operate as intended after the test. No degradation of performance or loss of function is allowed below a performance level specified by the manufacturer, when the apparatus is used as intended. The performance level may be replaced by a permissible loss of performance. During the test, degradation of performance is however allowed.
- C. Temporary loss of function is allowed, provided the function is self-recoverable or can be restored by the operation of the controls.

8 TEST RESULT

Test Point	Air Discharge	Contact Discharge	Performance Criteria	Result
HCP	---	$\pm 2, \pm 4KV$	B	PASSED
VCP	---	$\pm 2, \pm 4KV$	B	PASSED
CASE	$\pm 2, \pm 4, \pm 8KV$	$\pm 2, \pm 4KV$	B	PASSED
I/O PORTS	$\pm 2, \pm 4, \pm 8KV$	$\pm 2, \pm 4KV$	B	PASSED
LED	$\pm 2, \pm 4, \pm 8KV$	$\pm 2, \pm 4KV$	B	PASSED
SCREWS	$\pm 2, \pm 4, \pm 8KV$	$\pm 2, \pm 4KV$	B	PASSED
DC SOCKET	$\pm 2, \pm 4, \pm 8KV$	$\pm 2, \pm 4KV$	B	PASSED

※ The screen was flash during the test. After the test, EUT resume automatically.

9 Photos of test configuration please refer to appendix A.

RADIO FREQUENCY ELECTROMAGNETIC FIELD IMMUNITY TEST (RS)

1 TEST INSTRUMENTS & FACILITIES

Item	Instruments Facilities	Manufacturer	Model # Serial #	Data Of Cal.
1	SIGNAL GENERATOR	ROHDE & SCHWARZ	SMY02 845181/025	MAR/2007
2	AMPLIFIER	AMPLIFIER RESEARCH	100W1000M1A	N/A
3	FIELD SENSOR	AMPLIFIER RESEARCH	FP2000	AUG/2006
4	FIELD MONITOR	AMPLIFIER RESEARCH	FM2000	AUG/2006
5	RF VOLTMETER	BOONTON	9200C 361701AA	MAR/2007
6	RF PROBE	BOONTON	952001B 37082	MAR/2007
7	DIRECTION COUPLER	AMPLIFIER RESEARCH	DC6180 20521	N/A
8	ANTENNA	EMCO	3142B S/N: 1789	N/A
9	CONTROL PC	KB TECH	KB P586/133	--

Note : Items 3 ~ 4 were calibrated with two years and verified before testing.

2 TEST PROCEDURE

According to **IEC 61000-4-3 (2002)**

According to **EN 55024 (1998) + A1 (2001) + A2 (2003)**

3 TEST SETUP

FERRITE TILE

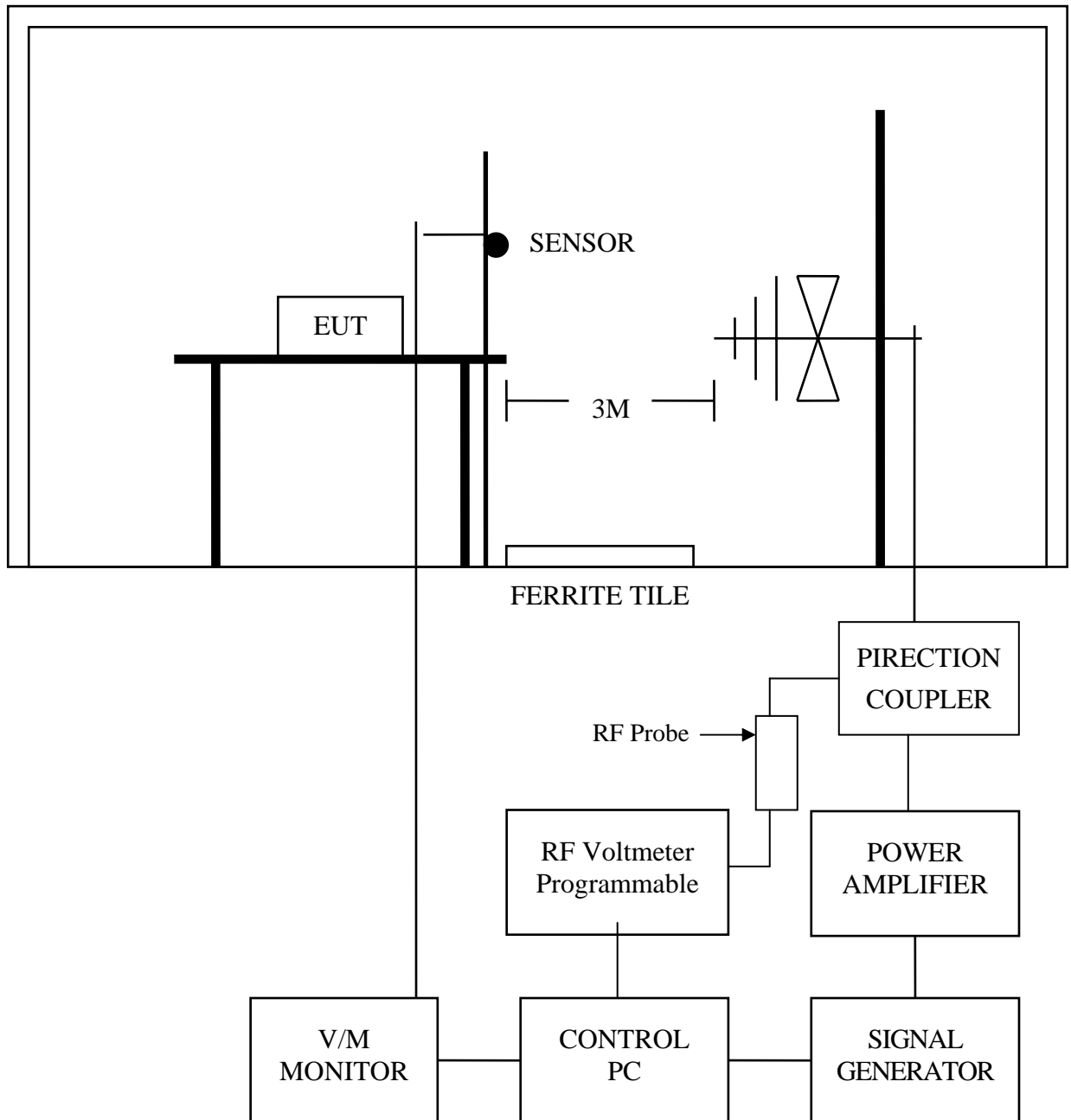

3.1 Chamber Size :

12M x 5M x 5M

(Details for setup configuration, please refer to appendix A.)

4 CONFIGURATION OF THE EUT

Same as “Conducted Power Line test”, section 4

5 OPERATION CONDITION OF EUT

Same as “Conducted Power Line test”, section 5

6 TEST CONDITION

6.1 Frequency Range : 80 MHz ~ 1000 MHz

(Frequency Range : 1.4 GHz ~ 2.0 GHz is not applicable for EN55024:1998+A1:2001+A2:2003)

6.2 Filed Strength : 3 V / M (1KHz 80% Modulation)

6.3 Frequency Step : 1 %, 3 sec. / each step size

6.4 Antenna Polarity : HORIZONTAL & VERTICAL

6.5 The four sides of EUT are tested
(FRONT, REAR, RIGHT, LEFT)

6.6 Temperature : 23 °C

6.7 Humidity : 50 % RH

7 PERFORMANCE CRITERIA

- A. The apparatus shall continue to operate as intended during and after the test. No degradation of performance or loss of function is allowed below a performance level specified by the manufacturer, when the apparatus is used as intended.
- B. The apparatus shall continue to operate as intended after the test. No degradation of performance or loss of function is allowed below a performance level specified by the manufacturer, when the apparatus is used as intended. The performance level may be replaced by a permissible loss of performance. During the test, degradation of performance is however allowed.
- C. Temporary loss of function is allowed, provided the function is self-recoverable or can be restored by the operation of the controls.

8 TEST RESULT

ANT SIDE	HORIZONTAL	VERTICAL	RESULT
FRONT	A	A	PASSED
REAR	A	A	PASSED
RIGHT	A	A	PASSED
LEFT	A	A	PASSED

9 Photos of test configuration please refer to appendix A.

ELECTRICAL FAST TRANSIENT/BURST IMMUNITY TEST (EFT)

1 TEST INSTRUMENTS & FACILITIES

Instruments/ Facilities	Manufacturer	Model # Serial #	Data Of Cal.
BURST-TESTER	HAEFELY	PEFT/JUNIOR	FEB/2007
CONTROL PC	KB TECH	KB P586/133	--

2 TEST PROCEDURE

According to **IEC 61000-4-4 (2004)**

According to **EN 55024 (1998) + A1 (2001) + A2 (2003)**

3 TEST SETUP

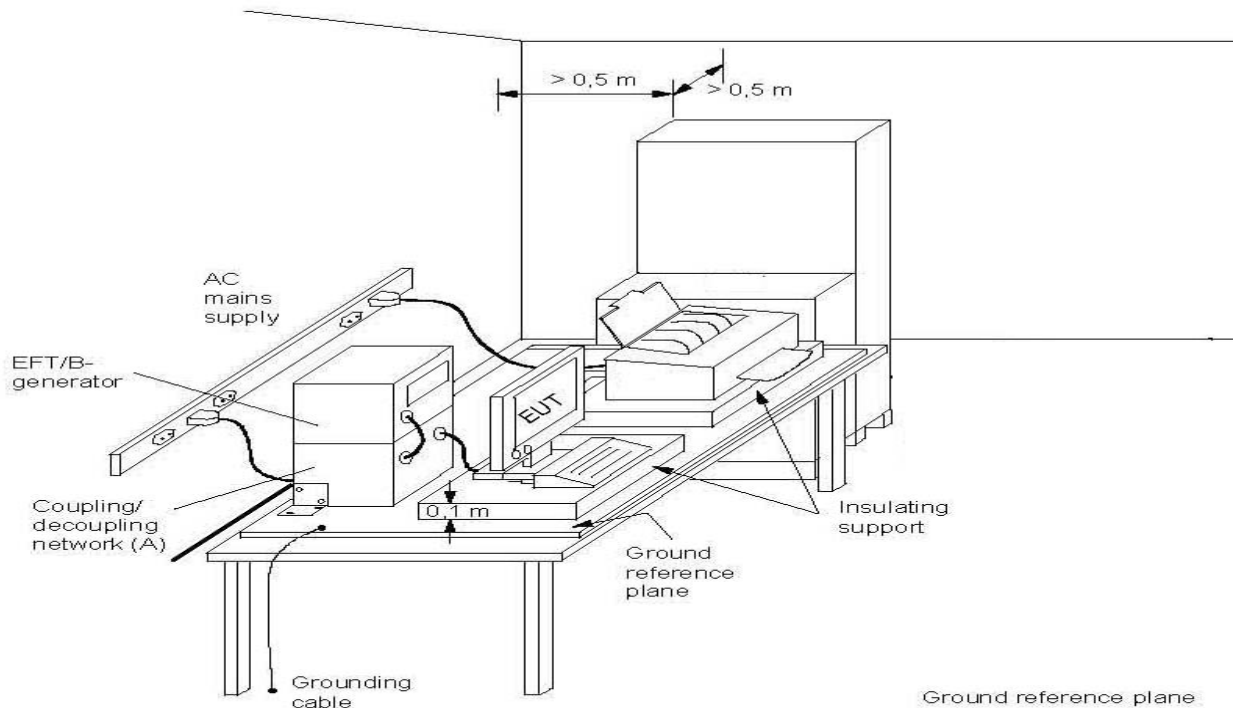

(Details for setup configuration, please refer to appendix A.)

Note: length between clamp and the EUT to be tested (should be $0.5 \text{ m} \pm 0.05 \text{ m}$)

(A) location for supply line coupling

(B) location for signal line coupling

4 CONFIGURATION OF THE EUT

Same as “Conducted Power Line test”, section 4

5 OPERATION CONDITION OF EUT

Same as “Conducted Power Line test”, section 5

6 TEST CONDITION

6.1 Pulse Rise time & Duration : 5 nS / 50 nS

6.2 Pulse Repetition : 5 kHz

6.3 Polarity : POSITIVE / NEGATIVE

6.4 Test Voltage : $\pm 0.5\text{KV}$, $\pm 1\text{KV}$

6.5 Coupling of power line :

L, N, L+N

6.6 Temperature : 24 °C

6.7 Humidity : 54 % RH

7 PERFORMANCE CRITERIA

- A. The apparatus shall continue to operate as intended during and after the test. No degradation of performance or loss of function is allowed below a performance level specified by the manufacturer, when the apparatus is used as intended.
- B. The apparatus shall continue to operate as intended after the test. No degradation of performance or loss of function is allowed below a performance level specified by the manufacturer, when the apparatus is used as intended. The performance level may be replaced by a permissible loss of performance. During the test, degradation of performance is however allowed.
- C. Temporary loss of function is allowed, provided the function is self-recoverable or can be restored by the operation of the controls.

8 TEST RESULT

TEST VOLTAGE	L	N	L+N
$\pm 0.5\text{KV}$	B	B	B
$\pm 1\text{KV}$	B	B	B

- ✘ The screen was flash in the picture during the test.
After the test, EUT resume automatically.

8.1 Model : UE01 (Receiver)

8.2 Final Result : PASSED

8.3 Remark :

9 Photos of test configuration please refer to appendix A.

SURGE IMMUNITY TEST

1 TEST INSTRUMENTS & FACILITIES

Instruments/ Facilities	Manufacturer	Model # Serial #	Data Of Cal.
SURGER-TESTER	HAEFELY	PSURGE 4010 583334-38	FEB/2007
CONTROL PC	KB TECH	KB P586/133	--

2 TEST PROCEDURE

According To **IEC 61000-4-5 (2001)**

According To **EN 55024 (1998) + A1 (2001) + A2 (2003)**

3 TEST SETUP

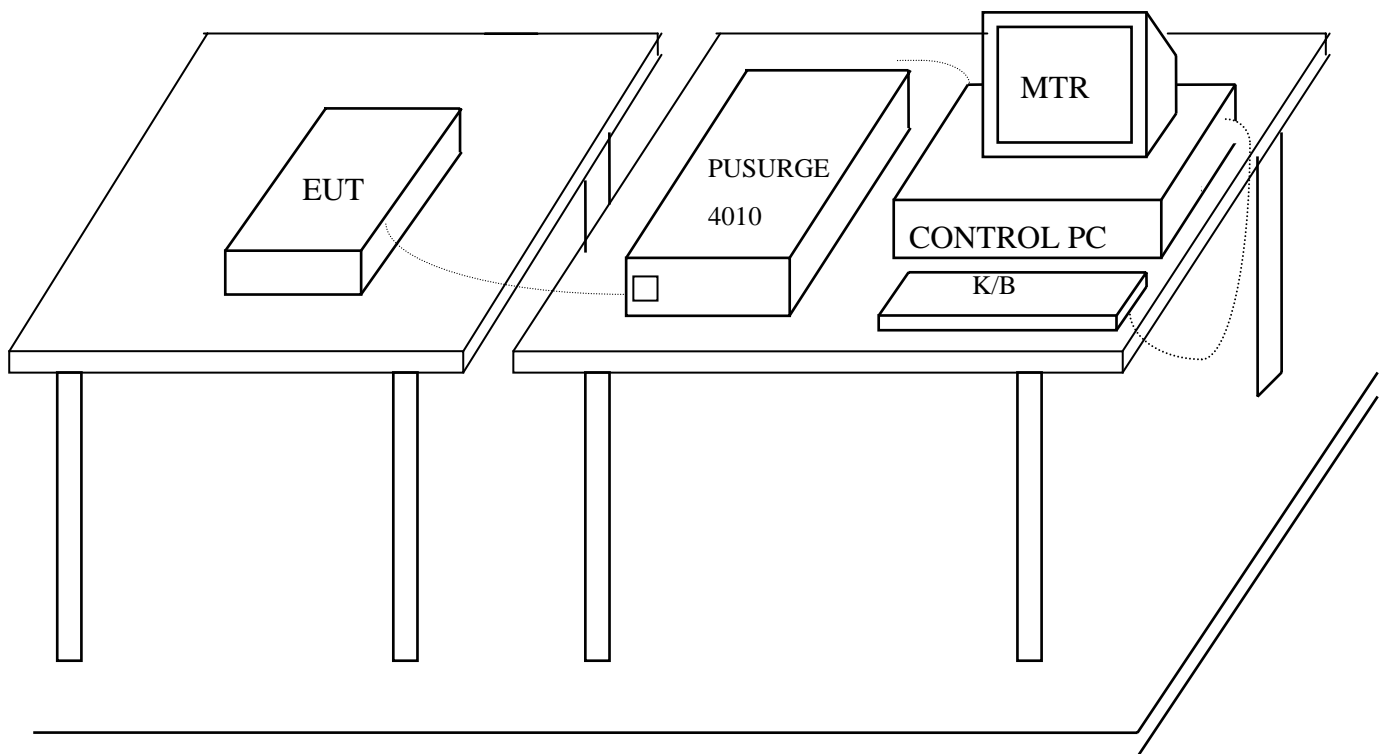

GROUND PLANE
(Details for setup configuration, please refer to appendix A.)

4 TEST LEVELS

- Input and Output AC Power Ports.
- DC Input and DC Output Power Ports.

Environmental Phenomena	Test Specification		Units	Performance Criteria
	AC	DC		
Surges	1.2 / 50 (8/20)		Tr /Th us	
Line to Line	±1	±0.5	KV (Charge Voltage)	B

5 CONFIGURATION OF THE EUT

Same as “Conducted Power Line test”, section 4

6 EUT OPERATION CONDITION

Same as “Conducted Power Line test”, section 5

7 CONDITIONS DURING TESTING

7.1 Coupling of power line :

(A) Line to Line ±1KV (AC) or ±0.5KV (DC)

7.2 Polarity : POSITIVE / NEGATIVE

7.3 Phase shifting in a range between 0° to 360°

7.4 Repletion rate at least 1 per min

7.5 Temperature : 24 °C (15°C ~ 35°C)

Humidity : 54 % RH.(10 % ~ 75%)

8 PERFORMANCE CRITERIA

- A. The apparatus shall continue to operate as intended during and after the test. No degradation of performance or loss of function is allowed below a performance level specified by the manufacturer, when the apparatus is used as intended.
- B. The apparatus shall continue to operate as intended after the test. No degradation of performance or loss of function is allowed below a performance level specified by the manufacturer, when the apparatus is used as intended. The performance level may be replaced by a permissible loss of performance. During the test, degradation of performance is however allowed.
- C. Temporary loss of function is allowed, provided the function is self-recoverable or can be restored by the operation of the controls.

9 TEST RESULT

Environmental Phenomena	Test Specification	Units	Performance
Line to Line	± 1	KV (Charge Voltage)	A

9.1 Model : UE01 (Receiver)

9.2 Final Result : PASSED

9.3 Remark :

10 Photos of test configuration please refer to appendix A.

IMMUNITY TEST TO CS CONDUCTED DISTURBANCE

1 TEST INSTRUMENTS & FACILITIES

Instruments/ Facilities	Manufacturer	Model # Serial #	Date Of Cal.
SIGNAL GENERATOR	ROHDE & SCHWARZ	SMY02 845181/025	MAR/2007
AMPLIFIER	AMPLIFIER RESEARCH	75A250 25680	N/A
RF VOLTMETER	BOONTON	9200C 361701AA	MAR/2007
RF PROBE	BOONTON	952001B 37082	MAR/2007
DIRECTION COUPLER	AMPLIFIER RESEARCH	DC2600 20508	N/A
COUPLING DECOUPLING NETWORK	FCC	FCC-801-M3-25A 9993	FEB/2007
CONTROL PC	KB TECH	KB P586/133	--

2 TEST PROCEDURE

According To **IEC 61000-4-6 (2003) + A1 (2004)**

According To **EN 55024 (1998) + A1 (2001) + A2 (2003)**

3 TEST SETUP

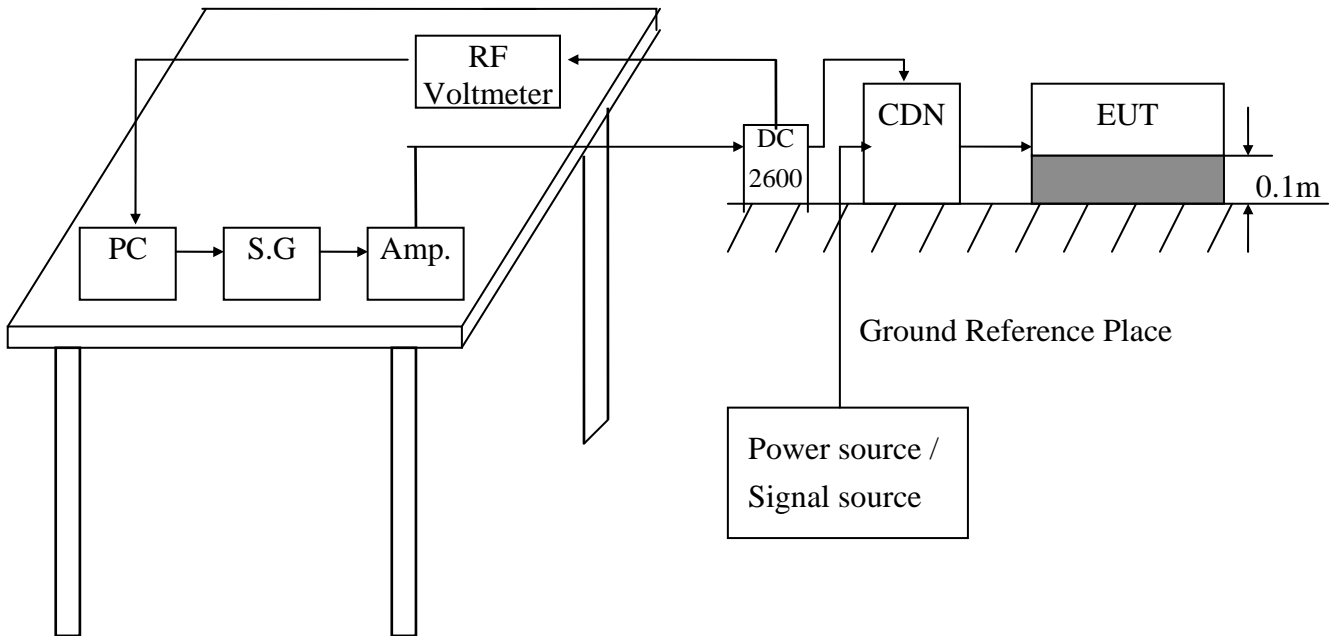

(Details for setup configuration, please refer to appendix A.)

4 TEST LEVELS

- Ports for signal lines and control lines.
- DC input and DC output power ports.
- Input and Output AC Power Ports.
- Functional earth Ports.

Environmental	Test Specification	Units	Performance
Radio-frequency	0.15 - 80	MHz	
Common mode	3	V	A
	80	% AM (1KHz)	

5 CONFIGURATION OF THE EUT

Same as “Conducted Power Line test”, section 4

6 EUT OPERATION CONDITION

Same as “Conducted Power Line test”, section 5

7 CONDITIONS DURING TESTING

7.1 The EUT tested type :

- Single unit
- Multiple unit

7.2 Dwell time : < 1%

7.3 Temperature : 24 °C (15°C ~ 35°C)
 Humidity : 54 % RH.(10 % ~ 75%)

8 PERFORMANCE CRITERIA

- A. The apparatus shall continue to operate as intended during and after the test. No degradation of performance or loss of function is allowed below a performance level specified by the manufacturer, when the apparatus is used as intended.
- B. The apparatus shall continue to operate as intended after the test. No degradation of performance or loss of function is allowed below a performance level specified by the manufacturer, when the apparatus is used as intended. The performance level may be replaced by a permissible loss of performance. During the test, degradation of performance is however allowed.
- C. Temporary loss of function is allowed, provided the function is self-recoverable or can be restored by the operation of the controls.

9 TEST RESULT

TEST Specification	Unit	Performance Criteria
0.15 - 80	MHz	A
3	V	
80	% AM (1KHz)	

9.1 Model : UE01 (Receiver)

9.2 Final Result : PASSED

9.3 Remark :

10 Photos of test configuration please refer to appendix A.

POWER FREQUENCY MAGNETIC FIELD IMMUNITY TEST

1 TEST INSTRUMENTS & FACILITIES

Instruments/ Facilities	Manufacturer	Model # Serial #	Data Of Cal.
LINE INTERFERENCE TESTER	HAEFELY	PLINE 1610 080166-10	FEB/2007
MAGNETIC FIELD TESTER	HAEFELY	MAG 100.1 080206-01	N/A
TRIAXIAL ELF MAGNETIC FIELD METER	F.W.BELL	4080 9645	AUG/2006
CONTROL PC	KB TECH	KB P586/133	--

2 TEST STANDARD

According To **IEC 61000-4-8 (2001)**

According To **EN 55024 (1998) + A1 (2001) + A2 (2003)**

3 TEST SETUP

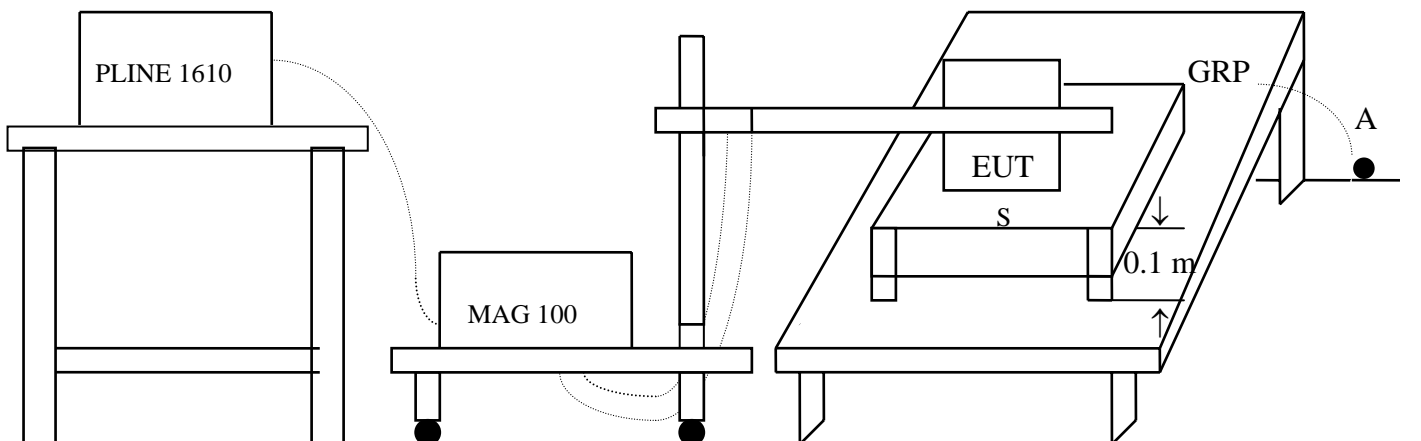

S: Insulating support

A: Safety earth

GRP: Ground plane

(Details for setup configuration, please refer to appendix A.)

4 TEST LEVELS

Environmental Phenomena	Test Specification	Units	Performance Criteria
Power Frequency	50	HZ	
Magnetic Field	1	A/m	B

5 CONFIGURATION OF THE EUT

Same as “Conducted Power Line test”, section 4

6 OPERATION CONDITION OF EUT

Same as “Conducted Power Line test”, section 5

7 CONDITIONS DURING TESTING

7.1 Temperature : 24 °C (15°C ~ 35°C)

Humidity : 54 % RH.(25 % ~ 75%)

7.2 The induction coil shall be rotated by 90°

8 PERFORMANCE CRITERIA

- A. The apparatus shall continue to operate as intended during and after the test. No degradation of performance or loss of function is allowed below a performance level specified by the manufacturer, when the apparatus is used as intended.
- B. The apparatus shall continue to operate as intended after the test. No degradation of performance or loss of function is allowed below a performance level specified by the manufacturer, when the apparatus is used as intended. The performance level may be replaced by a permissible loss of performance. During the test, degradation of performance is however allowed.
- C. Temporary loss of function is allowed, provided the function is self-recoverable or can be restored by the operation of the controls.

9 TEST RESULTS

Environmental Phenomena	Test Specification	Units	Performance Criteria
Magnetic Field	1	A/m	A

9.1 Model : UE01 (Receiver)

9.2 Final Results : PASSED

9.3 Remark :

10 Photos of test configuration please refer to appendix A.

VOLTAGE DIPS, SHORT INTERRUPTIONS IMMUNITY TEST

1 TEST INSTRUMENTS & FACILITIES

Instruments/ Facilities	Manufacturer	Model # Serial #	Data Of Cal.
LINE INTERFERENCE -TESTER	HAEFELY	PLINE 1610 080166-10	FEB/2007
CONTROL PC	KB TECH	KB P586/133	--

2 TEST PROCEDURE

According To **IEC 61000-4-11 (2004)**

According To **EN 55024 (1998) + A1 (2001) + A2 (2003)**

3 TEST SETUP

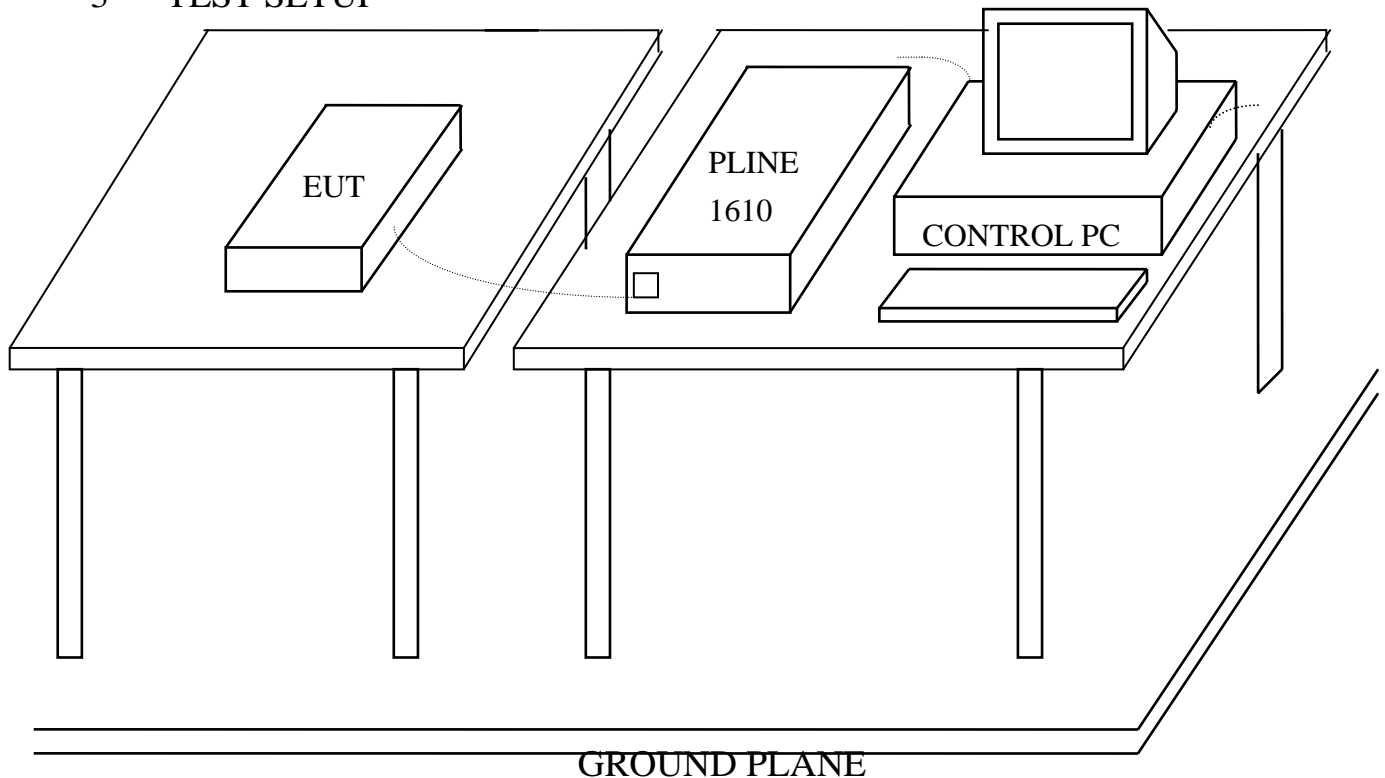

(Details for setup configuration, please refer to appendix A.)

4 TEST LEVELS

Input and Output AC Power Ports.

- Voltage Dips.
- Voltage Interruptions.

Class ^a	Test level and durations for voltage dips				
Class 1	Case-by-case according to the equipment requirements				
Class 2	0 % during 1/2 cycle	0 % during 1 cycle	70 % during 25/30 ^c cycles		
Class 3	0 % during 1/2 cycle	0 % during 1 cycle	40 % during 10/12 ^c cycles	70 % during 25/30 ^c cycles	80 % during 250/300 ^c cycles
a: Classes as per IEC 61000-2-4. b: To be defined by product committee. For equipment connected directly or indirectly to the public network, the levels must not be less severe than Class 2. c: “25/30 cycles” means “25 cycles for 50 Hz test” and “30 cycles for 60 Hz tet”.					

Class ^a	Test level and durations for short interruptions (t _s) (50Hz / 60Hz)
Class 1	Case-by-case according to the equipment requirements
Class 2	0 % during 250/300 ^c cycles
Class 3	0 % during 250/300 ^c cycles
Class X ^b	X
a: Classes as per IEC 61000-2-4. b: To be defined by product committee. For equipment connected directly or indirectly to the public network, the levels must not be less severe than Class 2. c: “250/300 cycles” means “250 cycles for 50 Hz test” and “300 cycles for 60 Hz test”.	

✘ **According to the specification of EUT, Class 2 is applied.**

5 CONFIGURATION OF THE EUT

Same as “Conducted Power Line test”, section 4

6 EUT OPERATION CONDITION

Same as “Conducted Power Line test”, section 5

7 CONDITIONS DURING TESTING

7.1 Temperature : 24 °C (15°C ~ 35°C)

Humidity : 54 % RH.(25 % ~ 75%)

8 PERFORMANCE CRITERIA

- A. The apparatus shall continue to operate as intended during and after the test. No degradation of performance or loss of function is allowed below a performance level specified by the manufacturer, when the apparatus is used as intended.
- B. The apparatus shall continue to operate as intended after the test. No degradation of performance or loss of function is allowed below a performance level specified by the manufacturer, when the apparatus is used as intended. The performance level may be replaced by a permissible loss of performance. During the test, degradation of performance is however allowed.
- C. Temporary loss of function is allowed, provided the function is self-recoverable or can be restored by the operation of the controls.

9 TEST RESULT

Environmental Phenomena	Test Specification	Units	Perform Criteria
Voltage Dips	0 1/2	% during Cycle	A
	0 1	% during Cycle	C
	70 25	% during Cycles	C
Voltage Short Interruptions	0	% during	C
	250	Cycles	

9.1 Model : UE01 (Receiver)

9.2 Final Results : PASSED

9.3 Remark :

10 Photos of test configuration please refer to appendix A.



HomeTek Technology Inc.

Appendix A

PHOTOS OF TEST CONFIGURATION

PHOTO OF CONDUCTED POWER LINE TEST

Front View



Rear View

PHOTO OF RADIATED EMISSION TEST



Front View



Rear View

**PHOTO OF HARMONICS & VOLTAGE FLUCTUATIONS TEST
AND SURGE IMMUNITY TEST AND VOLTAGE DIPS, SHORT
INTERRUPTIONS IMMUNITY TEST**



**PHOTO OF ELECTRICAL FAST TRANSIENT/BURST IMMUNITY
TEST**



**PHOTO OF ELECTROSTATIC DISCHARGE IMMUNITY TEST
(ESD)**



**PHOTO OF POWER FREQUENCY MAGNETIC FIELD
IMMUNITY TEST**



PHOTO OF RADIO FREQUENCY ELECTROMAGNETIC FIELD IMMUNITY TEST (RS)



PHOTO OF CS CONDUCTED DISTURBANCE IMMUNITY TEST





HomeTek Technology Inc.

Appendix B

PHOTOS OF EUT

PHOTO OF EUT

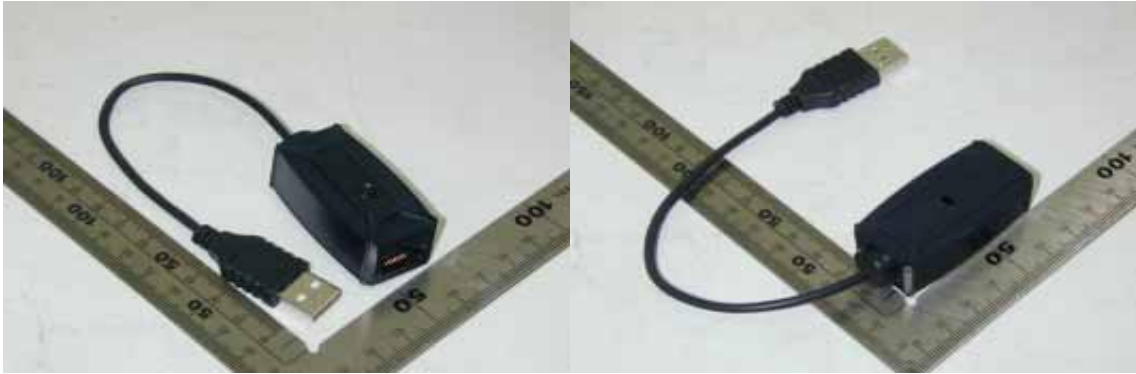

Full View of EUT

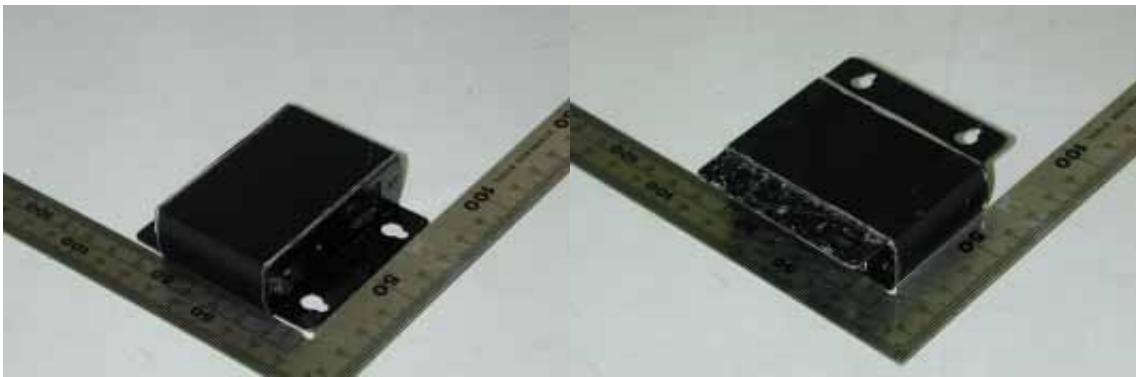

Full View of EUT

PHOTO OF EUT



Full View of EUT



Full View of EUT

PHOTO OF EUT

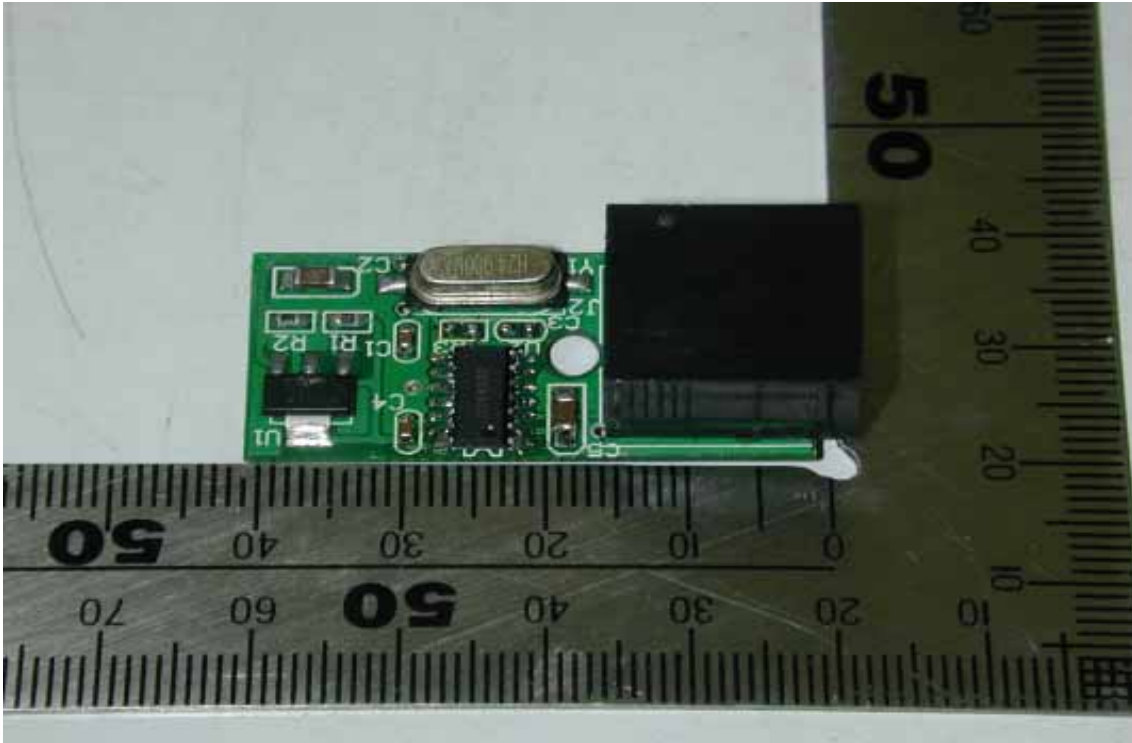

Component Side of Main Board 1

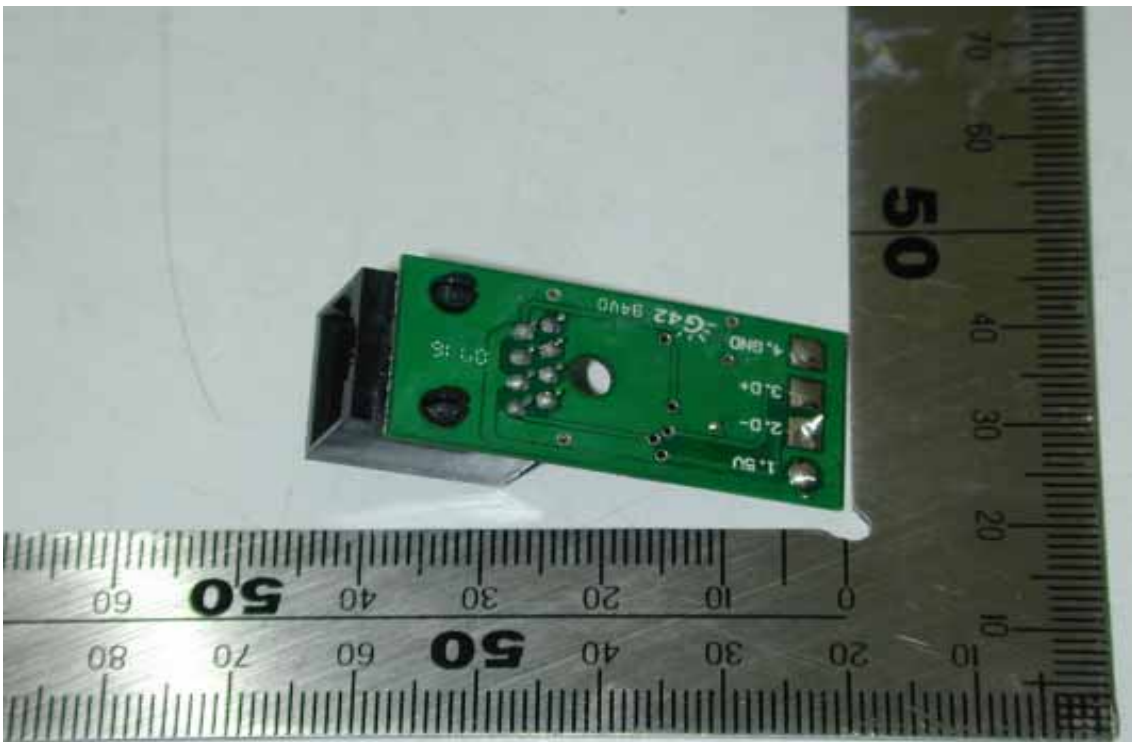

Solder Side of Main Board 1

PHOTO OF EUT

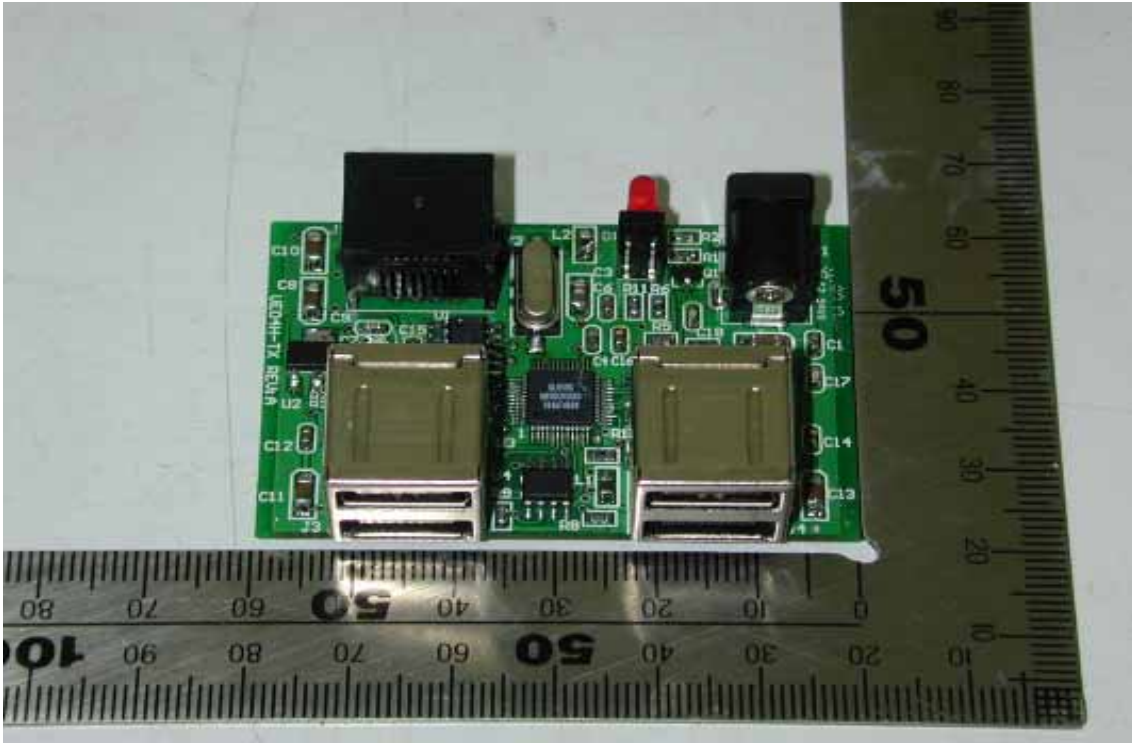

Component Side of Main Board 2

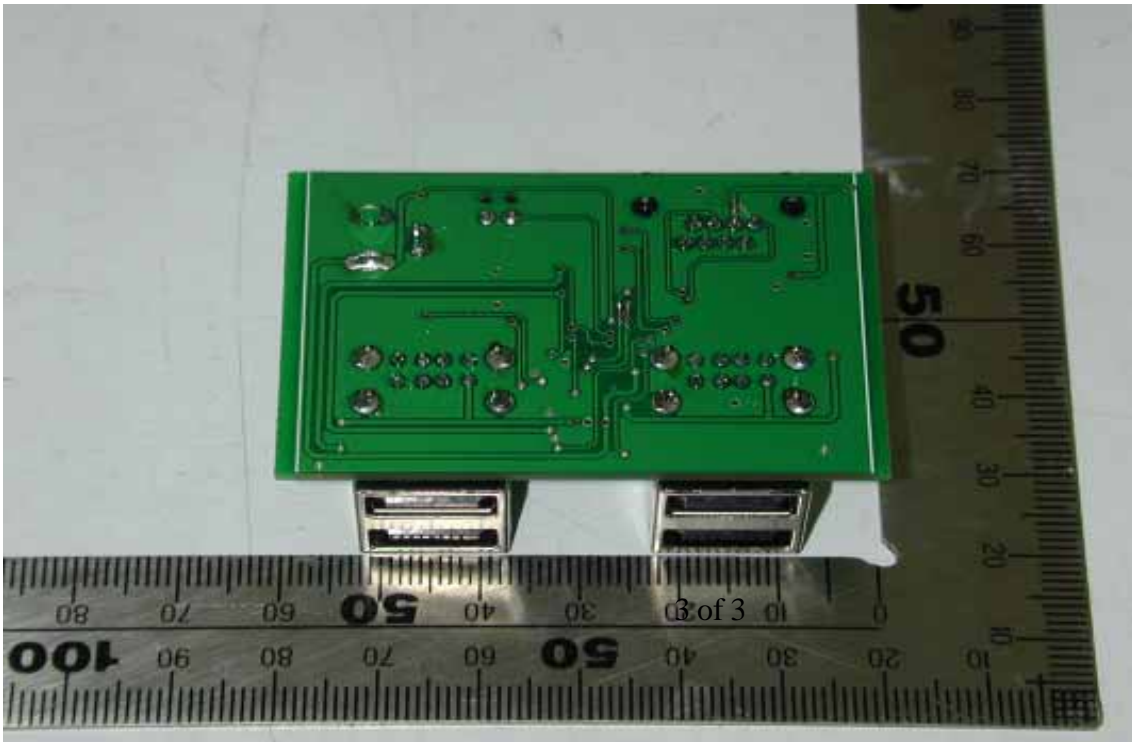

Solder Side of Main Board 2

PHOTO OF EUT



Front View of Adapter



Rear View of Adapter

Declaration of Conformity

We(Manufacturer/Importer)

(company name)

(address)

declares under our sole responsibility that the product

Product name : USB CAT5 extender with 4 port USB hub

Model No. : UE0XXX

to which this declaration relates is in conformity with the following standard(s) or other normative document(s)

- | | |
|---|---|
| <input checked="" type="checkbox"/> EN 55022 Class B (1998) | <input checked="" type="checkbox"/> EN 55024 (1998) |
| + A1 (2000) | + A1 (2001) |
| + A2 (2003) | + A2 (2003) |
| <input checked="" type="checkbox"/> EN 61000-3-2 (2000) | <input checked="" type="checkbox"/> IEC 61000-4-2 (2001) |
| <input checked="" type="checkbox"/> EN 61000-3-3 (1995) | <input checked="" type="checkbox"/> IEC 61000-4-3 (2002) |
| + A1 (2001) | <input checked="" type="checkbox"/> IEC 61000-4-4 (2004) |
| | <input checked="" type="checkbox"/> IEC 61000-4-5 (2001) |
| | <input checked="" type="checkbox"/> IEC 61000-4-6 (2003) |
| | + A1 (2004) |
| | <input checked="" type="checkbox"/> IEC 61000-4-8 (2001) |
| | <input checked="" type="checkbox"/> IEC 61000-4-11 (2004) |

following the provisions of 2004/108/EC Directive

Place: _____ Signature: _____

Date : _____ Full name: _____



Title: _____



TÜV Rheinland Taiwan Ltd.

Certificate

of

Appointment

for the applicant:

Hometek Technology Inc.
No. 67-9, Shir Men Rd., Tu-Cheng City,
Taipei Hsien 236, Taiwan, R.O.C.

has been authorized to carry out EMC tests by order and under supervision of TÜV Rheinland. It has successfully demonstrated capability to conduct measurement and to process test data according to:

**European and International EMC Standards as listed in the
Scope of Authorization on the attachment to this certificate**

An assessment of the facility was conducted by TÜV Rheinland auditors according to the TÜV Rheinland requirements for "Test Site Approval" with reference to

ISO 17 025:1999

Certificate No. : 10012161-2006

Valid until : June 14, 2007

TÜV Rheinland Taiwan Ltd.
Taipei, April 13, 2006

Dipl.-Ing. Andreas Klinker
Certification Body

Dipl.-Ing. Bodo Kretzschmar
Product Safety and Quality



Attachment to
Certificate
of Appointment

SCOPE OF AUTHORIZATION

Hometek Technology Inc.
No. 67-9, Shir Men Rd., Tu-Cheng City,
Taipei Hsien 236, Taiwan, R.O.C.

European Standards

EN 50081-1	EN 61000-3-2	ENV 50140
EN 50081-2	EN 61000-3-3	ENV 50141
EN 50082-1	EN 61000-6-1	ENV 50204
EN 50130-4	EN 61000-6-2	
EN 50091-2	EN 61000-6-3	
EN 55011	EN 61000-6-4	
EN 55013	EN 61000-3-11	
EN 55014-1	EN 61000-4-2	
EN 55014-2	EN 61000-4-3	
EN 55022	EN 61000-4-4	
EN 55024	EN 61000-4-5	
EN 60601-1-2	EN 61000-4-6	
EN 60801	EN 61000-4-8	
EN 60945	EN 61000-4-11	
	EN 61204-3	

International Standards

CISPR 11	IEC 61000-4-2	IEC 61000-3-2
CISPR 13	IEC 61000-4-3	IEC 61000-3-3
CISPR 14-1	IEC 61000-4-4	IEC 61000-3-11
CISPR 14-2	IEC 61000-4-5	IEC 61000-6-1
CISPR 22	IEC 61000-4-6	IEC 61000-6-2
CISPR 24	IEC 61000-4-8	IEC 61000-6-3
	IEC 61000-4-11	IEC 61000-6-4
IEC 801.2	IEC 61000-4-12	IEC 60945
IEC 801.3		
IEC 801.4		

Certificate No. : 10012161-2006

Taipei, April 13, 2006

Dipl.-Ing. Bodo Kretzschmar
Product Safety and Quality



TÜV Rheinland Taiwan Ltd.

Certificate of Appointment

for the applicant:

**Hometek Technology Inc.
No. 67-9, Shir Men Rd., Tu-Cheng City,
Taipei Hsien 236, Taiwan, R.O.C.**

has been authorized to carry out EMC tests by order and under supervision of TÜV Rheinland. It has successfully demonstrated capability to conduct measurement and to process test data according to:

**European and International EMC Standards as listed in the
Scope of Authorization on the attachment to this certificate**

An assessment of the facility was conducted by TÜV Rheinland auditors according to the TÜV Rheinland requirements for "Test Site Approval" with reference to

ISO 17025: 2005

Certificate No. : 10012161-2007

Valid until : Sept. 7, 2008

TÜV Rheinland Taiwan Ltd.
Taipei, June 20, 2007

Dipl.-Ing. Andreas Klinker
Certification Body

Dipl.-Ing. Bodo Kretzschmar
Product Safety and Quality



Attachment to
Certificate

of Appointment

SCOPE OF AUTHORIZATION

Hometek Technology Inc.
No. 67-9, Shir Men Rd., Tu-Cheng City,
Taipei Hsien 236, Taiwan, R.O.C.

European Standards

EN 50081-1	EN 61000-3-3	ENV 50140
EN 50081-2	EN 61000-6-1	ENV 50141
EN 50082-1	EN 61000-6-2	ENV 50204
EN 50130-4	EN 61000-6-3	
EN 50091-2	EN 61000-6-4	
EN 55011	EN 61000-3-11	
EN 55013	EN 61000-4-2	
EN 55014-1	EN 61000-4-3	
EN 55014-2	EN 61000-4-4	
EN 55022	EN 61000-4-5	
EN 55024	EN 61000-4-6	
EN 60601-1-2	EN 61000-4-8	
EN 60801	EN 61000-4-11	
EN 60945	EN 61204-3	
EN 61000-3-2	EN 62040-2	

International Standards

CISPR 11	IEC 61000-4-2	IEC 61000-3-2
CISPR 13	IEC 61000-4-3	IEC 61000-3-3
CISPR 14-1	IEC 61000-4-4	IEC 61000-3-11
CISPR 14-2	IEC 61000-4-5	IEC 61000-6-1
CISPR 22	IEC 61000-4-6	IEC 61000-6-2
CISPR 24	IEC 61000-4-8	IEC 61000-6-3
IEC 801.2	IEC 61000-4-11	IEC 61000-6-4
IEC 801.3	IEC 61000-4-12	IEC 60945
IEC 801.4		IEC 62040-2

Certificate No. : 10012161-2007

Taipei, June 20, 2007

Dipl.-Ing. Bodo Kretzschmar
Product Safety and Quality