



ADDRESS: No. 67-9, Shir Men Road, Tu Cheng City,
Taipei Hsien, Taiwan

PHONE : 886-2-22608375 FAX : 886-2-22748013

E - mail : hometek@ms15.hinet.net

CE TEST REPORT FOR

APPLICANT : Smart Home Engineering Corp.
ADDRESS : 10F, No. 493, Chung-Cheng Rd.,
Hsin Tien City, Taipei 231, Taiwan, R. O. C.
Receipt Date : 11/08/2007 Final Test Date: 12/06/2007
EUT : Corrector
MODEL NO. : XX01X

MEASUREMENT PROCEDURE USED

EN55022 CLASS B / EN61000-3-2 / EN61000-3-3 / EN55024 GIVEN IN
EUROPEAN COUNCIL DIRECTIVE 2004/108/EC

This test result of this report applies to above tested sample only.

This test report shall not be reproducing in part without written approval of HomeTek Technology Inc.

PREPARED BY :

HomeTek Technology Inc.

No. 67-9, Shir Men Road, Tu Cheng City,

Taipei Hsien. Taiwan

Report # : EB6K016

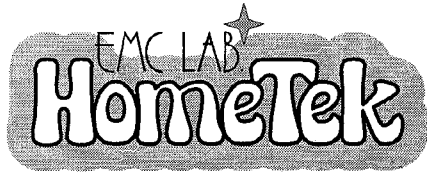

HomeTek Technology Inc.

ADDRESS: No. 67-9, Shir Men Road, Tu Cheng City,
Taipei Hsien

PHONE : 886-2-22608375 FAX : 886-2-22748013

E - mail : hometek@ms15.hinet.net

CERTIFICATE OF COMPLIANCE

EUT : Corrector

MODEL NO. : XX01X

Receipt Date : 11/08/2007 Final Test Date: 12/06/2007

REPORT # : EB6K016

APPLICANT : Smart Home Engineering Corp.

ADDRESS : 10F, No. 493, Chung-Cheng Rd.,
Hsin Tien City, Taipei 231, Taiwan, R. O. C.

Measurement procedure used:

EMI: EN 55022 Class B (1998) + A1 (2000) + A2 (2003),

EN 61000-3-2 (2006), EN 61000-3-3 (1995) + A1 (2001) + A2 (2005),

EMS: EN 55024 (1998) + A1 (2001) + A2 (2003):

IEC 61000-4-2 (2001), IEC 61000-4-3 (2002), IEC 61000-4-4 (2004), IEC 61000-4-5 (2001),

IEC 61000-4-6 (2003) + A1 (2004), IEC 61000-4-8 (2001), IEC 61000-4-11 (2004)

We hereby show that:

The measurements shown in this test report were made in accordance with the procedures given in **EUROPEAN COUNCIL DIRECTIVE 2004/108/EC**, and the energy emitted by the equipment was found to be within the limits applicable. This product, which has been issued the test report listed as above in HomeTek Technology Inc., is based on single evaluation of one sample and confirmed to comply with the requirements of the above-mentioned EMC standard.

APPROVED BY:



GRANT HUANG / Manager

TEST REPORT CERTIFICATION**EMC of electrical appliances**

Report reference No. : EB6K016
Date of issue : Dec., 14, 2007
Applicant : Smart Home Engineering Corp.
Address : 10F, No. 493, Chung-Cheng Rd.,
Hsin Tien City, Taipei 231, Taiwan, R. O. C.
Manufacturer : Smart Home Engineering Corp.
Type of test object : Corrector
Model/type reference : XX01X
EUT Voltage : DC5V by power adapter
Test Result : Complied
Testing laboratory : HomeTek Technology Inc.
Address : No. 67-9, Shir Men Road, Tu Cheng City, Taipei Hsien,
Taiwan, R. O. C.
TEL / FAX : +886-2-22608375 / +886-2-22748013
E-mail : hometek@ms15.hinet.net
Standard : EN 55022 Class B (1998) + A1 (2000) + A2 (2003),
EN 61000-3-2 (2006),
EN 61000-3-3 (1995) + A1 (2001) + A2 (2005),
EN 55024 (1998) + A1 (2001) + A2 (2003):
IEC 61000-4-2 (2001), IEC 61000-4-3 (2002),
IEC 61000-4-4 (2004), IEC 61000-4-5 (2001),
IEC 61000-4-6 (2003) + A1 (2004), IEC 61000-4-8 (2001),
IEC 61000-4-11 (2004)

Tested by (+ signature) :

Jason Lin / Engineer

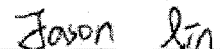

Approved by (+ signature) :

Grant Huang / Manager

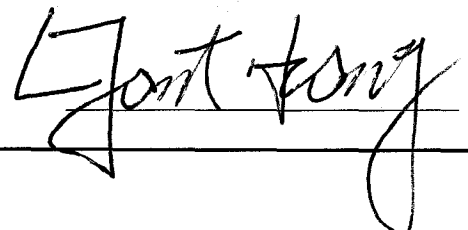



TEST REPORT CERTIFICATION..... 1

TABLE OF CONTENTS..... 2

TEST REPORT CERTIFICATION..... 1

GENERAL INFORMATION..... 5

MODIFICATION LIST..... 7

CONDUCTED POWER LINE TEST 8

1 TEST INSTRUMENTS & FACILITIES..... 8

2 TEST PROCEDURE..... 8

3 TEST SETUP 9

4 CONFIGURATION OF THE EUT 11

5 EUT OPERATING CONDITION..... 15

6 LIMIT OF CONDUCTED POWER LINE EMISSION CLASS B..... 15

7 RESULT OF CONDUCTED POWER LINE TEST..... 15

8 CONDUCTED POWER LINE TEST DATA (PAGE 1)..... 16

9 CONDUCTED POWER LINE TEST DATA (PAGE 2)..... 17

10 CONDUCTED POWER LINE TEST DATA (PAGE 3)..... 18

11 CONDUCTED POWER LINE TEST DATA (PAGE 4)..... 19

RADIATED EMISSION TEST..... 20

1 TEST INSTRUMENTS & FACILITIES..... 20

2 TEST PROCEDURE..... 21

3 TEST SETUP 21

4 CONFIGURATION OF THE EUT 23

5 EUT OPERATING CONDITION..... 23

6 LIMIT OF RADIATED EMISSION CLASS B 23

7 RESULT OF RADIATED EMISSION TEST..... 23

8 RADIATED EMISSION TEST DATA (PAGE 1)..... 24

9 RADIATED EMISSION TEST DATA (PAGE 2)..... 25

HARMONICS TEST..... 26

1 TEST INSTRUMENTS & FACILITIES..... 26

2 TEST PROCEDURE..... 26

3 TEST SETUP 26

4 CONFIGURATION OF THE EUT 26

5 OPERATION CONDITION OF EUT 26

6 TEST DATA & LIMIT..... 26

7 HARMONICS TEST DATA (PAGE 1~2)..... 27

VOLTAGE FLUCTUATIONS TEST 29

1 TEST INSTRUMENTS & FACILITIES..... 29

2 TEST PROCEDURE..... 29

3 TEST SETUP 29



4 CONFIGURATION OF THE EUT 29

5 OPERATION CONDITION OF EUT 29

6 TEST DATA & LIMIT 29

7 VOLTAGE FLUCTUATIONS TEST DATA (PAGE 1) 30

ELECTROSTATIC DISCHARGE IMMUNITY TEST (ESD) 31

1 TEST INSTRUMENTS & FACILITIES 31

2 TEST PROCEDURE 31

3 TEST SETUP 31

4 CONFIGURATION OF THE EUT 32

5 EUT OPERATION CONDITION 32

6 TEST CONDITION 32

7 PERFORMANCE CRITERIA 32

8 TEST RESULT 33

RADIO FREQUENCY ELECTROMAGNETIC FIELD IMMUNITY TEST (RF) 34

1 TEST INSTRUMENTS & FACILITIES 34

2 TEST PROCEDURE 34

3 TEST SETUP 35

4 CONFIGURATION OF THE EUT 36

5 OPERATION CONDITION OF EUT 36

6 TEST CONDITION 36

7 PERFORMANCE CRITERIA 36

8 TEST RESULT 37

ELECTRICAL FAST TRANSIENT/BURST IMMUNITY TEST (EFT) 38

1 TEST INSTRUMENTS & FACILITIES 38

2 TEST PROCEDURE 38

3 TEST SETUP 38

4 CONFIGURATION OF THE EUT 39

5 OPERATION CONDITION OF EUT 39

6 TEST CONDITION 39

7 PERFORMANCE CRITERIA 39

8 TEST RESULT 40

SURGE IMMUNITY TEST 41

1 TEST INSTRUMENTS & FACILITIES 41

2 TEST PROCEDURE 41

3 TEST SETUP 41

4 TEST LEVELS 42

5 CONFIGURATION OF THE EUT 42

6 EUT OPERATION CONDITION 42

7 CONDITIONS DURING TESTING 42

8 PERFORMANCE CRITERIA 43



9 TEST RESULT 43

IMMUNITY TEST TO CS CONDUCTED DISTURBANCE 44

1 TEST INSTRUMENTS & FACILITIES..... 44

2 TEST PROCEDURE..... 44

3 TEST SETUP 45

4 TEST LEVELS..... 46

5 CONFIGURATION OF THE EUT 46

6 EUT OPERATION CONDITION..... 46

7 CONDITIONS DURING TESTING..... 46

8 PERFORMANCE CRITERIA 47

9 TEST RESULT 47

POWER FREQUENCY MAGNETIC FIELD IMMUNITY TEST 48

1 TEST INSTRUMENTS & FACILITIES..... 48

2 TEST STANDARD..... 48

3 TEST SETUP 48

4 TEST LEVELS..... 49

5 CONFIGURATION OF THE EUT 49

6 OPERATION CONDITION OF EUT..... 49

7 CONDITIONS DURING TESTING..... 49

8 PERFORMANCE CRITERIA 49

9 TEST RESULTS 50

VOLTAGE DIPS, SHORT INTERRUPTIONS IMMUNITY TEST 51

1 TEST INSTRUMENTS & FACILITIES..... 51

2 TEST PROCEDURE..... 51

3 TEST SETUP 51

4 TEST LEVELS..... 52

5 CONFIGURATION OF THE EUT 52

6 EUT OPERATION CONDITION..... 52

7 CONDITIONS DURING TESTING..... 52

8 PERFORMANCE CRITERIA 53

9 TEST RESULT 53

APPENDIX A

PHOTOS OF TEST CONFIGURATION

APPENDIX B

PHOTOS OF EUT

GENERAL INFORMATION

- 1 APPLICANT : Smart Home Engineering Corp.
- 2 ADDRESS : 10F, No. 493, Chung-Cheng Rd.,
Hsin Tien City, Taipei 231, Taiwan, R. O. C.
- 3 MANUFACTURER : Smart Home Engineering Corp.
- 4 ADDRESS : 10F, No. 493, Chung-Cheng Rd.,
Hsin Tien City, Taipei 231, Taiwan, R. O. C.
- 5 DESCRIPTION OF EUT :
EUT : Corrector
Model : XX01X
Serial # : N/A

5.1 The difference between series of models XX01X are as shown below:

- (1) The first “X” represents different system input.
- (2) The second “X” represent different accessory.
- (3) The third “X” represent different color.

The PCB layout is similar. The worst case of EMC test data were shown in this test report.

6 FEATURES OF EUT :

Support Resolution	Up to 1600 x1200 @ 85Hz
Total delay	62ns
Step delay increments	2ns
input Signals	RGB Analog (75 Ω , 0.7VP-P)
	Sync Signal H/V Separated (TTL)
Horizontal Frequency Range	30-95KHz
Vertical Frequency Range	50-180Hz
VGA Connector	15-pin Mini D-Sub (High Density)
Power Supply	DC12V/500mA
Power consumption	DC12V/120mA
Temperature	Operation: 0 to 55°C, Storage: -20 TO 85°C, Humidity: up to 95%
Dimensions W x H x D mm	133 x 71 x 44

7 TEST MODE :

The EUT were investigated with one resolution modes shown as below :

- (1) 1600 x 1200 Mode

The final test data were shown in this test report.

MODIFICATION LIST

THE FOLLOWING ACCESSORIES WERE ADDED TO THE EUT DURING TESTING :

NO MODIFICATION BY HOMETEK TECHNOLOGY INC.

CONDUCTED POWER LINE TEST

1 TEST INSTRUMENTS & FACILITIES

The following test Instruments was used during the conducted test :

Item	Instruments/ Facilities	Specification	Manufacturer	Model #	Date Of Cal.
1	EMI Receiver	9KHz ~ 30MHz	ROHDE & SCHWARZ	ESHS10 840449/001	DEC/2006
2	LISN (for EUT)	50Ω/50uH/16A 9KHz ~ 30MHz	AFJ	LT32 32039930056	DEC/2006
3	LISN (for Support Unit)	50Ω/50uH/15A 150KHz ~ 30MHz	SANKI	LISN1-15V 080404E	DEC/2006
4	Terminator	50Ω	N/A	N/A	DEC/2006
5	Attenuation	50Ω/10dB	Mini-Circuit	NAT-10 AT-002	DEC/2006
6	Cable	5.4m	SUHNER	RG-223 CON2-001	DEC/2006
7	ESXS-K1 (software)	Version 2.03b 9KHz ~ 30MHz	ROHDE & SCHWARZ	1082.9678.02 840.913/246	N/A

Note : Items 1 ~ 6 were calibrated within period of 1 year.

2 TEST PROCEDURE

- 2.1 The EUT was tested according to **EN55022 Class B**.
- 2.2 The EUT was placed 0.4 meter from the conducting wall of shielding room and kept at least 0.8 meter from any other grounded conducting surface.
- 2.3 The frequency range form 0.15 MHz to 30 MHz was investigated.
- 2.4 The LISN used was 50 Ohm / 50 uHenry as specified by **EN55022**.
- 2.5 All the support peripherals are connect to the other LISN.
- 2.6 Cables and peripherals were moved to find the maximum emission levels for each frequency.

3 TEST SETUP

3.1 Typical : Setup Of Conducted Test

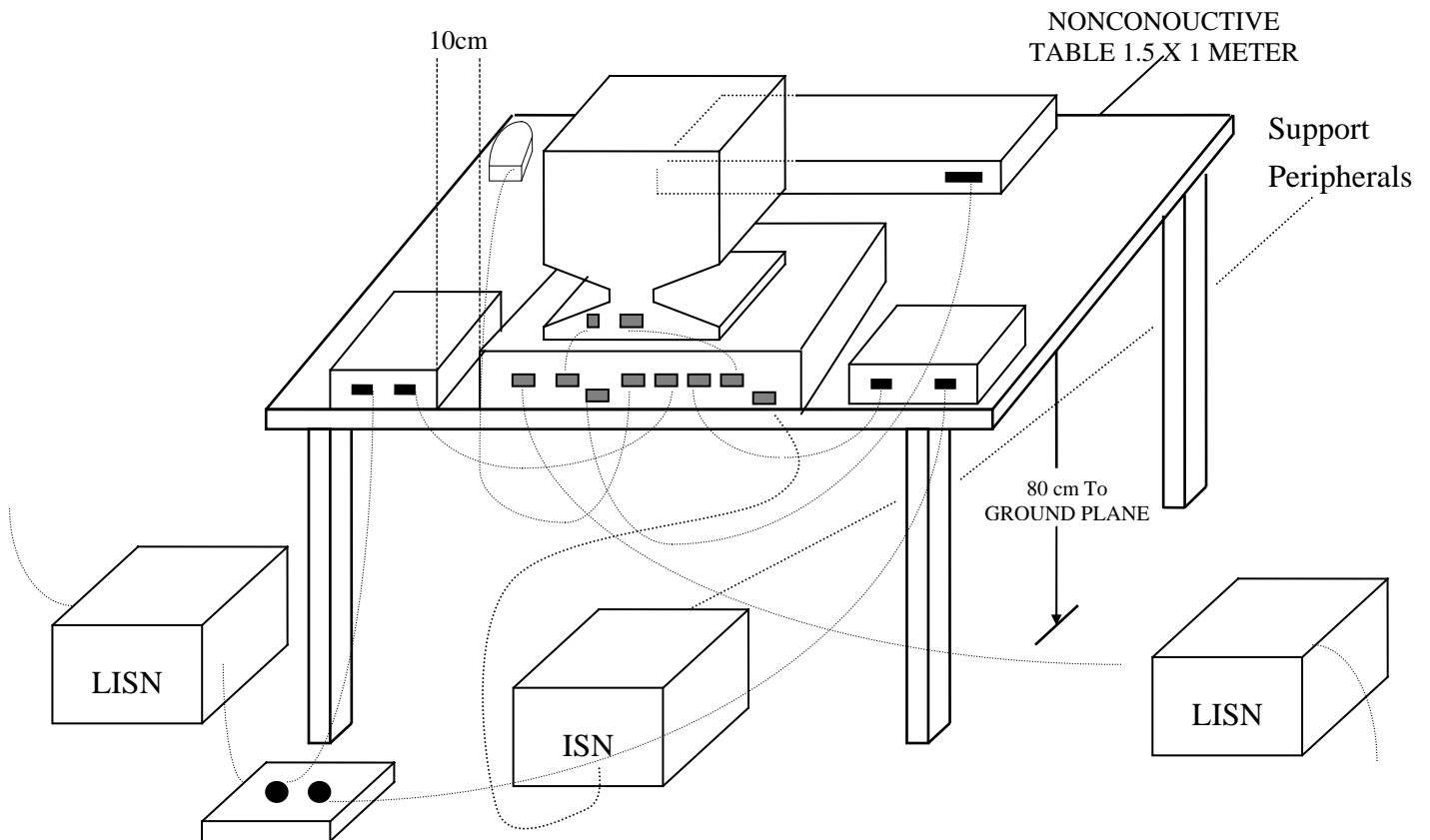

(Details for setup configuration, please refer to appendix A.)

3.2 Block Diagram Of Conducted Test

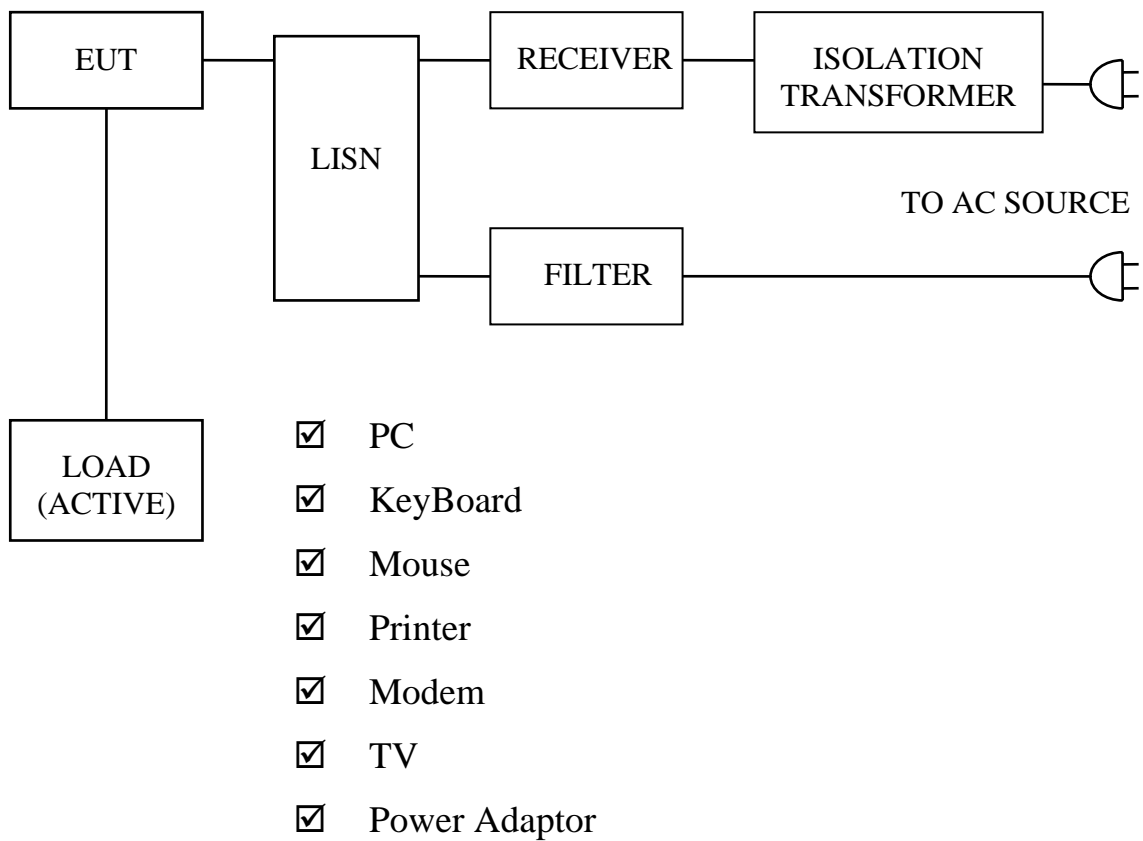



4 CONFIGURATION OF THE EUT

The EUT was configured according to **EN55022**. All I/O ports were connected to the appropriate peripherals. All peripherals and cables are listed below (including internal device) :

4.1 EUT

EUT Type	: <input type="checkbox"/> Proto Type <input checked="" type="checkbox"/> Engineer Type <input type="checkbox"/> Mass Production
Condition when received	: <input checked="" type="checkbox"/> Good <input type="checkbox"/> Damage : _____
Device	: Corrector
Applicant	: Smart Home Engineering Corp.
Manufacturer	: Smart Home Engineering Corp.
Model Number	: XX01X
Serial Number	: N/A
FCC ID	: N/A
VGA IN Port	: Metal Type Connector
VGA OUT Port	: Metal Type Connector
VGA Cable	: Shielded, 1.8 m, Metal Type Connector
Power Cord (AC)	: N/A
Power Cord (DC)	: Un-Shielded, 1.9 m
Power Supply Type	: Linear



4.2 PERIPHERALS

Host Personal Computer

Manufacturer : DELL
Model Number : DMC
Power Cord : Un-Shielded ,3pin,1.5m
Power Supply Type : Switching
Serial Number : JMM5L 1X
FCC ID : FCC DoC

KeyBoard

Manufacturer : DELL
Model Number : SK-8115
Serial Number : N/A
FCC ID : FCC DoC
Data Cable : Shielded,1.5 m,Connected to the USB port
Power Cord : N/A

Mouse

Manufacturer : DELL
Model Number : M056UOA
Serial Number : F1A01NWF
FCC ID : FCC DoC
Data Cable : Shielded,1.5 m,Connected to the USB port
Power Cord : N/A



Printer

Manufacturer : EPSON
Model Number : P310B
Serial Number : N/A
FCC ID : FCC DoC
Data Cable : Shielded, 1.5 m, Connected to the Printer port
Power Cord & Adaptor : Un-Shielded, 1.8 m

Modem

Manufacturer : ACEEX
Model Number : 1414
Serial Number : N/A
FCC ID : IFAXDM1414
Data Cable : Shielded, 1.5 m, Connected to the COM port
Power Cord & Adaptor : Un-Shielded, 1.8 m

TV

Manufacturer : SAMSUNG
Model Number : LA26R51B
Serial Number : N/A
FCC ID : FCC DoC
Power Cord : Un-Shielded, 1.5 m



Power Adaptor

Manufacturer : OEM

Model Number : ADP12500N-2

Serial Number : N/A

FCC ID : N/A

Data Cable : N/A

Power Cord (DC) : Un-Shielded, 1.9 m

4.3 REMARK : N/A

5 EUT OPERATING CONDITION

- 5.1 The frequency of the EUT is none.
- 5.2 Configure the EUT according to the **EN 55022 Class B**.
- 5.3 The test configuration included PC, TV, Keyboard, Mouse, Printer , Modem and Adaptor.
- 5.4 Turn on all the power of EUT and peripheral.
- 5.5 PC sends data signal (resolutions: 1600 x 1200) to TV via EUT’s VGA port.
- 5.6 During the test, the PC sends “H” patterns to each I/O port individually. EUT display “H” character.
- 5.7 Adjust the location of EUT and peripheral to gain the maximum EMI noise.
- 5.8 The photos of conducted test configuration, please refer to appendix A.**

6 LIMIT OF CONDUCTED POWER LINE EMISSION CLASS B

Frequency Range	Quasi Peak	Average
0.15 ~ 0.5 MHz	66 - 56 dBuV	56 - 46 dBuV
0.5 ~ 5 MHz	56 dBuV	46 dBuV
5 ~ 30 MHz	60 dBuV	50 dBuV

7 RESULT OF CONDUCTED POWER LINE TEST

- 7.1 The frequency range from 0.15 MHz to 30 MHz was investigated. All readings are quasi-peak values and average.
- 7.2 IF bandwidth : 9 kHz, Meas Time : 1 sec.
- 7.3 Temperature : 23.4 °C, Humidity : 40 % RH.
- 7.4 Deviations from the test standards and rules : None.
- 7.5 The conducted test result were gained by following procedures :
 Level = Reading Level + Insertion Loss of LISN + Cable Loss
 (All calculation were done by ESHS10 EMI test receiver.)
- 7.6 Result : **PASSED**

8 CONDUCTED POWER LINE TEST DATA (PAGE 1)

HomeTek EMC LAB. TEL :86-769-85303005 , 886-2-22608375

04 Dec 2007 13:36

CONDUCTED EMISSIONS

EUT: VS01
 Manuf: 6K016
 Cp Cond: LINE
 Operator: BELUNDA
 Test Spec: FOR EN55022 CLASS B
 Comment: 230V/50Hz
 1600 x 1200 MODE
 Result File: 6K0160011.dat

Prescan Measurement:	Detectors:	X PK / + AV
	Meas Time:	see scan settings
	Subranges:	8
	Acc Margin:	55 dB

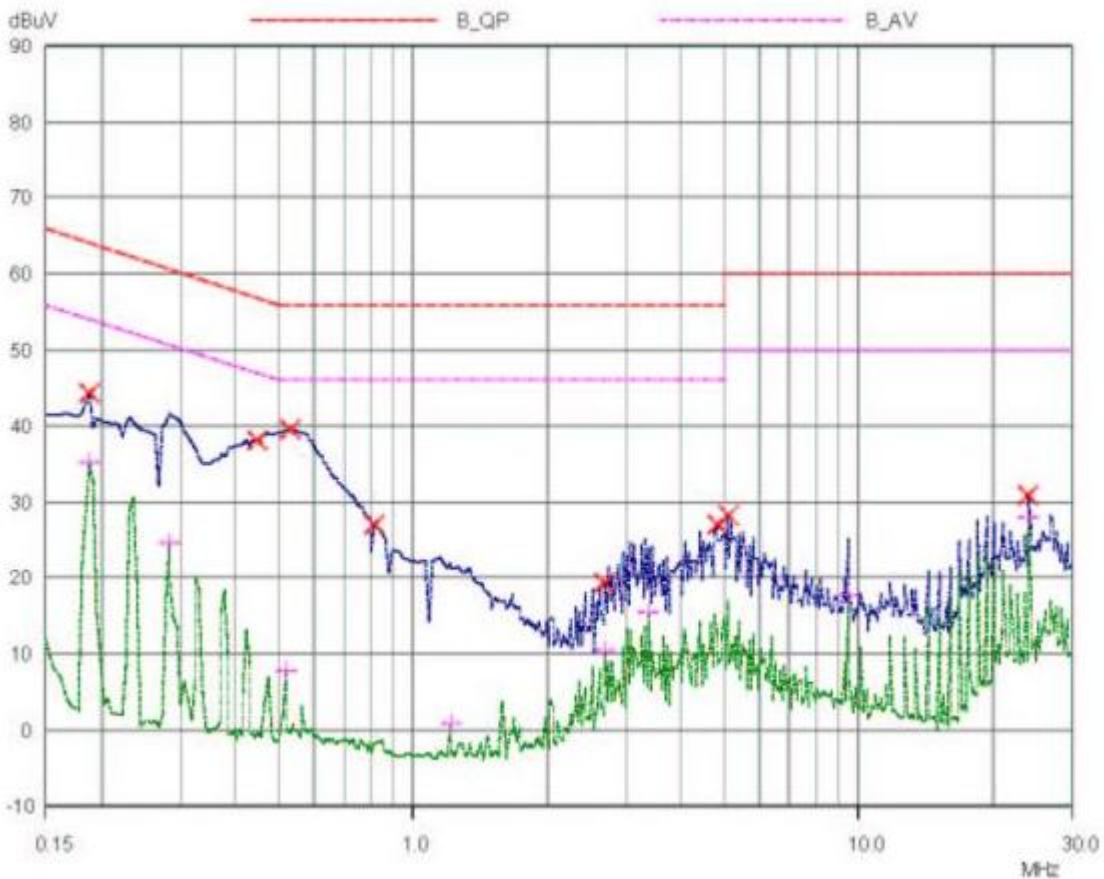



9 CONDUCTED POWER LINE TEST DATA (PAGE 2)

HomeTek EMC LAB. TEL :86-769-85303005 , 886-2-22608375

04 Dec 2007 13:36

CONDUCTED EMISSIONS

EUT: VS01
 Manuf: 6K016
 Op Cond: LINE
 Operator: BELINDA
 Test Spec: FOR EN55022 CLASS B
 Comment: 230V/50Hz
 1600 x 1200 MODE
 Result File: 6K0160011.dat :

Prescan Measurement: Detectors: X PK / + AV
 Meas Time: see scan settings
 Subranges: 8
 Acc Margin: 55 dB

Peak Search Results

Frequency MHz	PK Level dBuV	PK Limit dBuV	PK Delta dB
0.185	44.45	64.26	19.81
0.445	38.25	56.97	18.72
0.528	39.58	56.00	16.42
0.82	27.04	56.00	28.96
2.68	19.28	56.00	36.72
4.78	27.10	56.00	28.90
5.04	28.35	60.00	31.65
24.0	30.96	60.00	29.04

Frequency MHz	AV Level dBuV	AV Limit dBuV	AV Delta dB
0.185	35.33	54.26	18.93
0.28	24.78	50.82	26.04
0.515	7.84	46.00	38.16
1.2	0.82	46.00	45.18
2.68	10.59	46.00	35.41
3.36	15.48	46.00	30.52
9.44	17.70	50.00	32.30
24.0	27.99	50.00	22.01

* limit exceeded

10 CONDUCTED POWER LINE TEST DATA (PAGE 3)

HomeTek EMC LAB. TEL :86-769-85303005 , 886-2-22608375

04 Dec 2007 13:58

CONDUCTED EMISSIONS

EUT: VS01
 Manuf: 6K016
 Op Cond: NEUTRAL
 Operator: BELINDA
 Test Spec: FOR EN55022 CLASS B
 Comment: 230V/50Hz
 1600 x 1200 MODE
 Result File: 6K0160012.dat ;

Prescan Measurement: Detectors: X PK / + AV
 Meas Time: see scan settings
 Subranges: 8
 Acc Margin: 55 dB

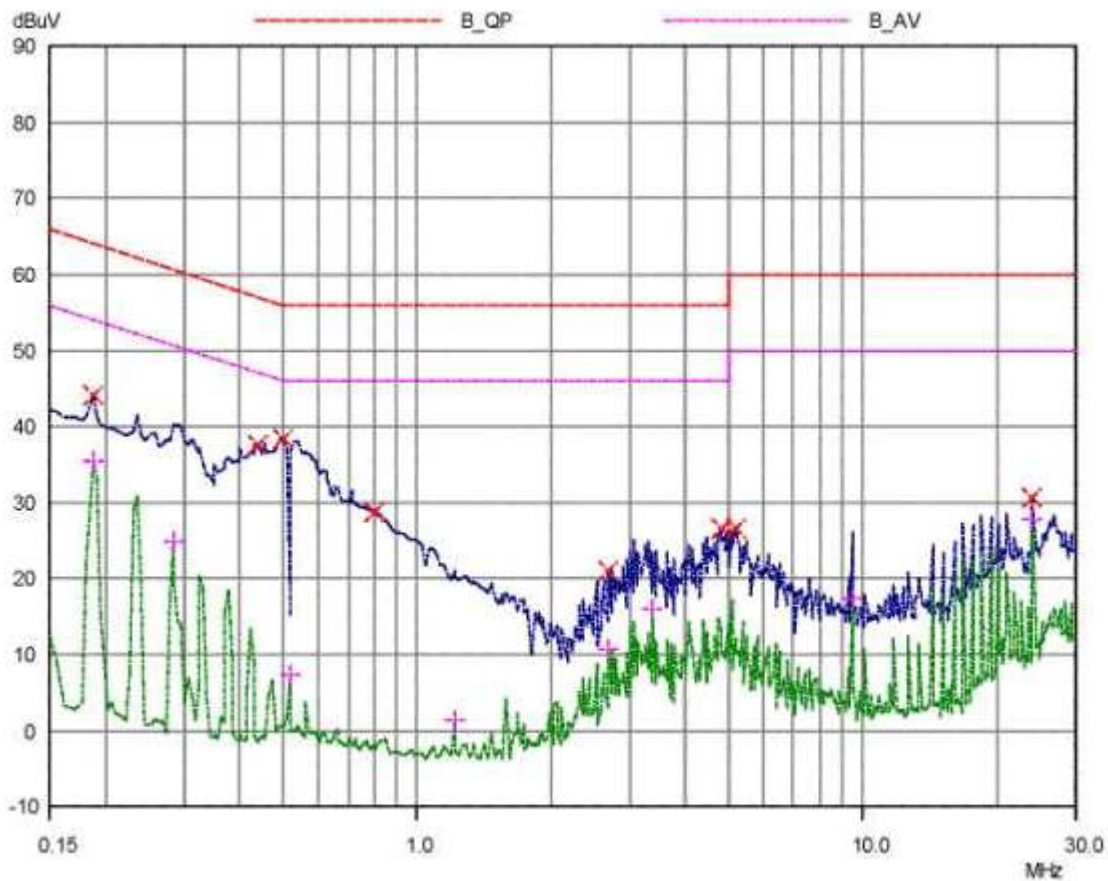



11 CONDUCTED POWER LINE TEST DATA (PAGE 4)

HomeTek EMC LAB. TEL :86-769-85303005 , 886-2-22608375

04Dec 2007 13:58

CONDUCTED EMISSIONS

EUT: VS01
 Manuf: 6K016
 Op Cond: NEUTRAL
 Operator: BELINDA
 Test Spec: FOR EN55022 CLASS B
 Comment: 230V/50Hz
 1600 x 1200 MODE
 Result File: 6K0160012.dat :

Prescan Measurement: Detectors: X PK / + AV
 Meas Time: see scan settings
 Subranges: 8
 Acc Margin: 55 dB

Peak Search Results

Frequency MHz	PK Level dBuV	PK Limit dBuV	PK Delta dB
0.185	44.14	64.26	20.12
0.44	37.68	57.06	19.38
0.502	38.39	56.00	17.61
0.8	28.75	56.00	27.25
2.68	21.05	56.00	34.95
4.78	26.51	56.00	29.49
5.16	26.72	60.00	33.28
24.0	30.77	60.00	29.23

Frequency MHz	AV Level dBuV	AV Limit dBuV	AV Delta dB
0.185	35.41	54.26	18.85
0.28	24.92	50.82	25.90
0.515	7.38	46.00	38.62
1.2	1.32	46.00	44.68
2.68	10.72	46.00	35.28
3.36	16.04	46.00	29.96
9.44	17.53	50.00	32.47
24.0	27.71	50.00	22.29

* limit exceeded

RADIATED EMISSION TEST

1 TEST INSTRUMENTS & FACILITIES

The following test Instruments was used during the radiated emission test :

Item	Instruments /facilities	Specification	Manufacturer	Model # / S/N#	Date of Cal.
1	OPEN AREA TEST SITE	<input checked="" type="checkbox"/> OATS 3	HomeTek	N/A	DEC/2006
2	EMI TEST RECEIVER	20Hz ~ 5GHz	ROHED& SCHWARZ	ESBI 845636/007	DEC/2006
3	PRE-AMPLIFIER	9KHz ~1300MHz	HEWLETT PACKARD	8447D 1937A02095	DEC/2006
4	ANTENNA (BI-LOG)	30MHz ~ 2GHz	ANTENNA RESEACH	LPB2520/A 1095	MAR/2007
5	Attenuation	50Ω/6dB	JYE BAO	FAT-N(M-F) 001	DEC/2006
6	Cable	10m	SUHNER	RG214/U OS3-003	DEC/2006
7	Cable	14m	BELDEN	9913 OS3-001	DEC/2006
8	EMI 32 (software)	N/A	AUDIX	19991013-0923	N/A

Note : Items 1 ~ 7 were calibrated within period of 1 year.

2 TEST PROCEDURE

- 2.1 The EUT was test according to **EN55022**.
- 2.2 The radiated test was performed at HomeTek Lab's Open Site 3.
- 2.3 The frequency range from 30 MHz to 1 GHz, the measurement were made at 10 meters, with a BI-log antenna.

3 TEST SETUP

3.1 TEST SETUP OF OPEN SITE.

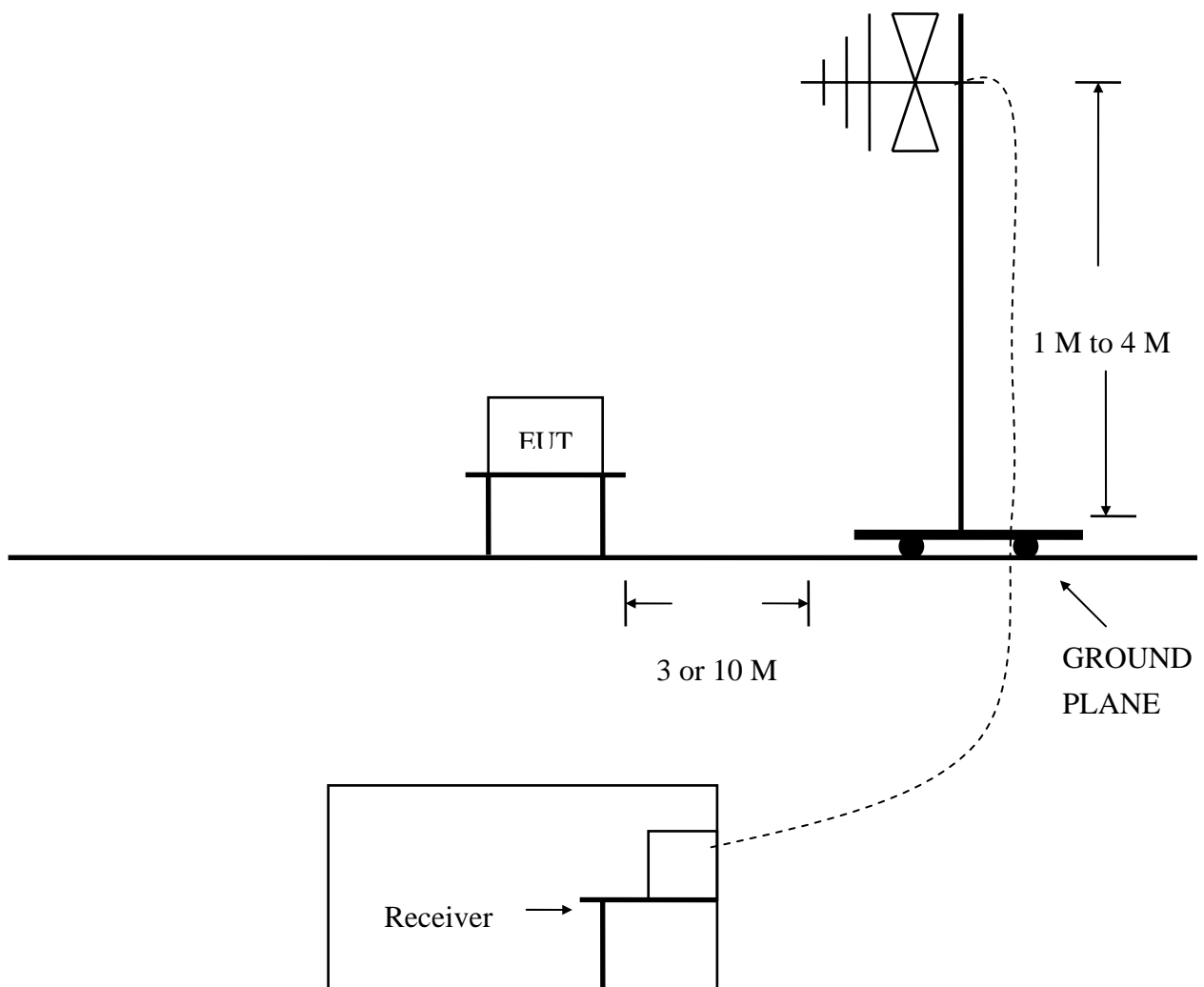

(Details for setup configuration, please refer to appendix A.)

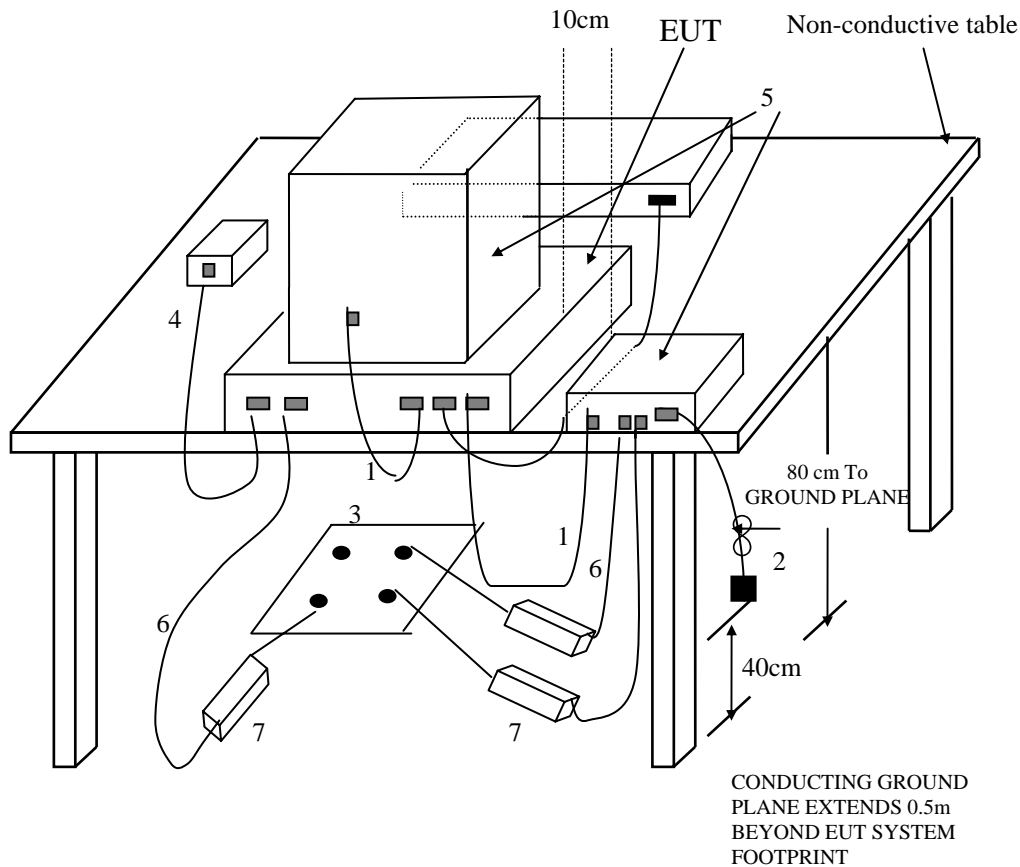

(Details for setup configuration, please refer to appendix A.)

LEGEND:

- 1.If cables, which hang closer than 40 cm to the horizontal metal ground plane cannot be shortened to the appropriate length, the excess shall be folded back and forth forming a bundle 30 cm to 40 cm long.
- 2.The end of I/O signal cables which are not connected to a peripheral may be terminated, if required for proper operation using correct terminating impedance.
- 3.Mains junction box(es) shall be flush with, and bonded directly to, the metal ground plane.
NOTE if used, the AMN shall be installed under the horizontal metal ground plane.
- 4.Cables of hand-operated devices such as keyboards, mice, etc. shall be placed as for normal usage.
- 5.Peripherals shall be placed at a distance of 10 cm from each other and from the controller, except for the monitor which, if for an acceptable installation practice, shall be placed directly on top of the controller.
- 6.Mains cables, telephone lines or other connections to auxiliary equipment located outside the test area shall drape to the floor, be fitted with ferrite clamps or ferrite tubes placed on the floor at the point where the cable reaches the floor and then routed to the place where they leave the turntable. No extension cords shall be used to mains receptacle.
- 7.Ferrite clamps or ferrite tubes with similar characteristics (as defined in 10.4). No more than one cable per clamp.

Test Configuration

Tabletop Equipment Radiated Measurement

4 CONFIGURATION OF THE EUT

Same as “Conducted Power Line test”, section 4

5 EUT OPERATING CONDITION

5.1 Same as “Conducted Power Line test”, section 5

5.2 The radiated emission in the frequency range from 30 MHz - 1000 MHz was test in a horizontal and vertical polarization at HomeTek Lab’s open site 3.

5.3 The photos of radiated test configuration, please refer to appendix A.

6 LIMIT OF RADIATED EMISSION CLASS B

Frequency (MHz)	Measurement Distance	Limit (dBuV/m)
30 - 230	10 (M)	30
230 - 1000	10 (M)	37

7 RESULT OF RADIATED EMISSION TEST

7.1 The frequency range from 30 MHz to 1 GHz was investigated.

7.2 All readings below or equal 1 GHz are quasi-peak or peak values with resolution bandwidth of 120 KHz.

7.3 The measurements were made at 10 meters of HomeTek Lab’s open site 3.

7.4 Temperature : 23.5 °C, Humidity : 39 % RH.

7.5 Deviation form the test standards and rules : None.

7.6 The radiated emission result were gained by the following method :

Level = Reading Level + Probe Factor (Antenna Factor) + Cable Loss – Preamp Factor
 Over Limit = Level – Limit Line

7.7 Result : **PASSED**



8 RADIATED EMISSION TEST DATA (PAGE 1)



HomeTek Technology Inc.

HomeTek Technology Inc.
Tel:02-22608375
Fax:02-22748013

Data#: 2 File#: 6K016.EMI

Date: 2007-12-04 Time: 09:33:14

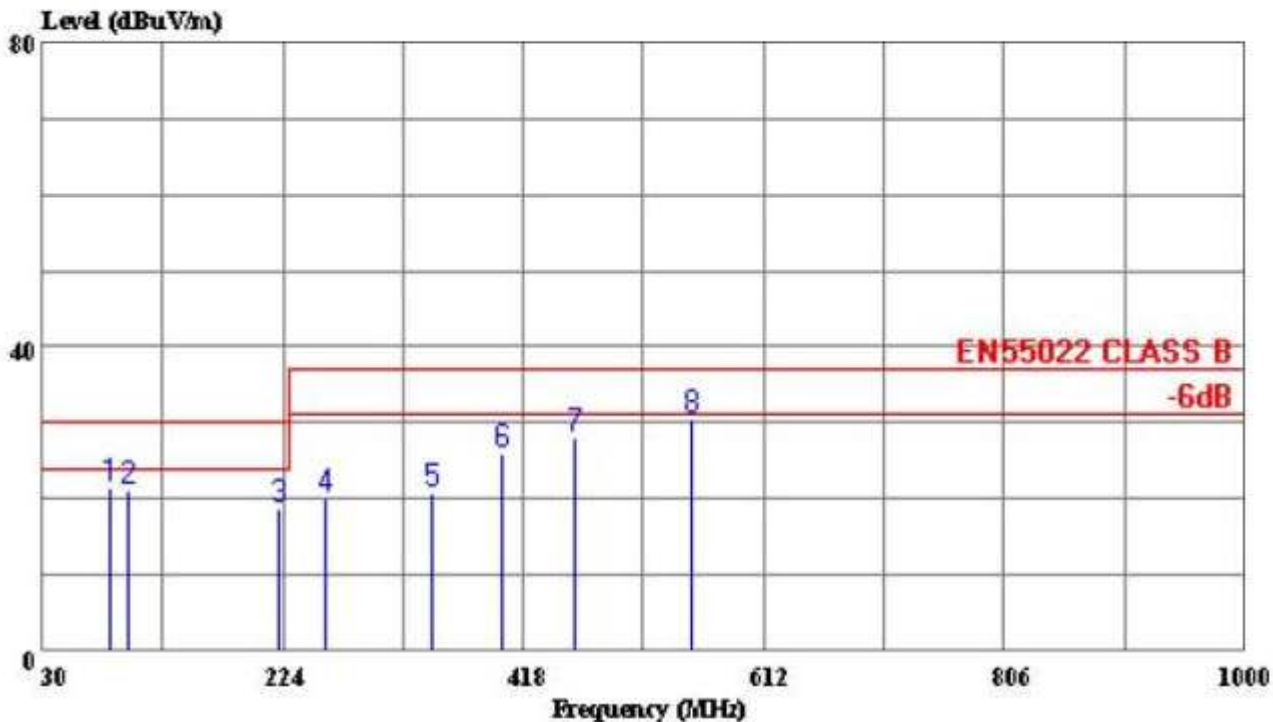

Trace:

Ref Trace:

Condition: EN55022 CLASS B 10m LPB-250/A-031028 HORIZONTAL
 out : VS01
 power: 230V/50Hz
 memo : 1600 x 1200 MODE

Page: 1

	Freq	Level	Limit	Over	Read		Remark
	MHz	dBuV/m	dBuV/m	dB	dBuV	dB	
1	84.320	21.59	30.00	-8.41	38.80	-17.21	Peak
2	99.840	21.02	30.00	-8.98	38.20	-17.18	QP
3	220.120	18.87	30.00	-11.13	37.10	-18.23	Peak
4	257.950	20.12	37.00	-16.88	36.00	-15.88	Peak
5	344.280	20.71	37.00	-16.29	32.00	-11.29	Peak
6	401.510	26.02	37.00	-10.98	37.10	-11.08	Peak
7	458.740	28.06	37.00	-8.94	38.90	-10.84	Peak
8	552.830	30.45	37.00	-6.55	36.80	-6.35	Peak



9 RADIATED EMISSION TEST DATA (PAGE 2)



HomeTek Technology Inc.
Tel:02-22608375
Fax:02-22748013

HomeTek Technology Inc.

Data#: 1 File#: 6K016.EMI Date: 2007-12-04 Time: 08:48:27

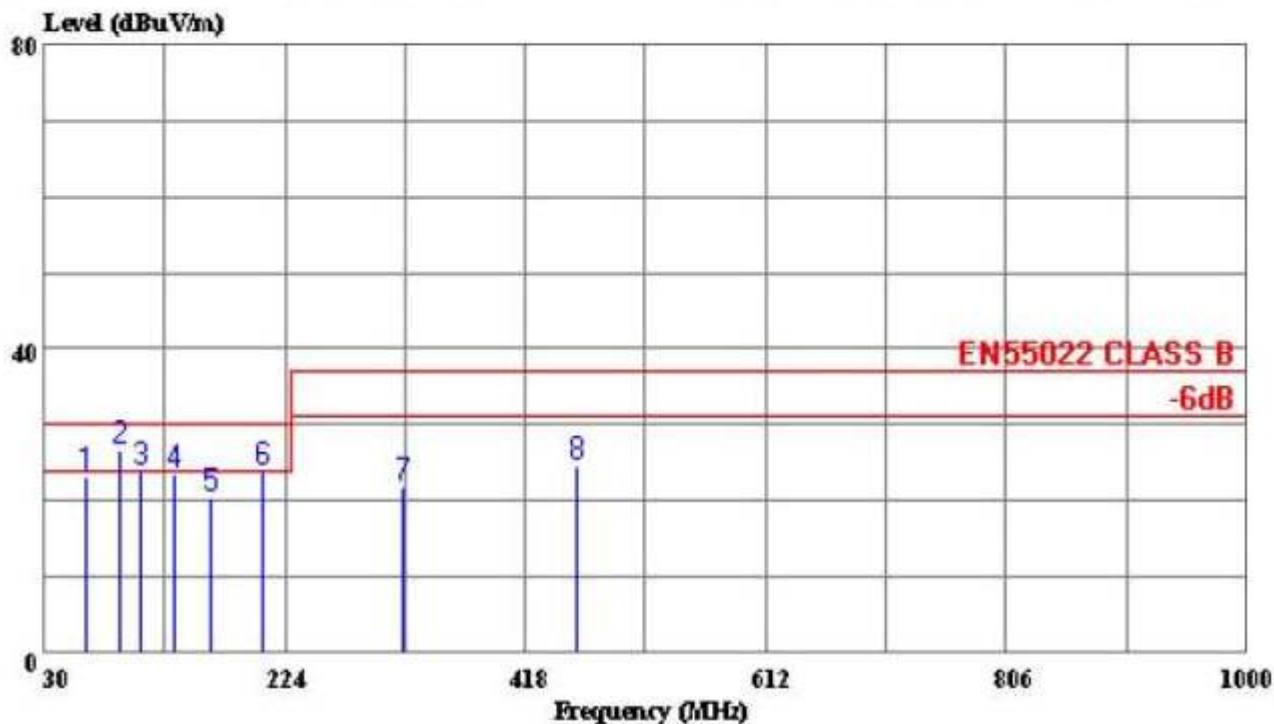

Trace:

Ref Trace:

Condition: EN55022 CLASS B 10m LPB-250/A-031028 VERTICAL
cut : VS01
power: 230V/50Hz
memo : 1600 x 1200 MODE

Page: 1

	Freq	Level	Limit	Over	Read	Factor	Remark
	MHz	dBuV/m	dBuV/m	dB	dBuV	dB	
1	62.980	23.30	30.00	-6.70	39.60	-16.30	Peak
2	91.110	26.64	30.00	-3.36	42.70	-16.06	QP
3	107.600	24.03	30.00	-5.97	40.10	-16.07	QP
4	135.730	23.40	30.00	-6.60	43.10	-19.70	Peak
5	163.860	20.59	30.00	-9.41	42.80	-22.21	Peak
6	205.570	23.77	30.00	-6.23	38.90	-15.13	Peak
7	319.060	21.66	37.00	-15.34	28.30	-6.64	Peak
8	458.740	24.53	37.00	-12.47	36.50	-11.97	Peak

HARMONICS TEST

1 TEST INSTRUMENTS & FACILITIES

Instruments/ facilities	Manufacturer	Model # Serial #	Date of Cal.
POWER FREQUENCY TEST SYSTEM	HAEFELY	PHF555 080419-12	JAN/2007
CONTROL PC	KB TECH	KB P586/133	N/A

2 TEST PROCEDURE

According to **EN 61000-3-2 (2006) Class A**

3 TEST SETUP

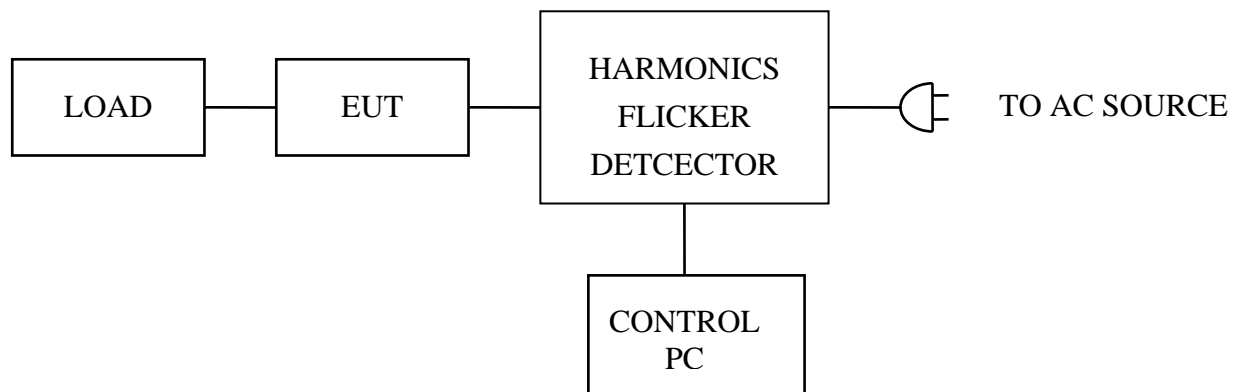

(Details for setup configuration, please refer to appendix A.)

4 CONFIGURATION OF THE EUT

Same as “Conducted Power Line test”, section 4

5 OPERATION CONDITION OF EUT

Same as “Conducted Power Line test”, section 5

6 TEST DATA & LIMIT

6.1 Temperature : 22.7 °C

6.2 Humidity : 38 % RH



7 HARMONICS TEST DATA (PAGE 1~2)

EN61000-3-2 TEST REPORT 2007/12/04 21:20 PM

Unit : Corrector
Serial No.: VS01
Remarks : 1600 x 1200 MODE
Operator : BLINDA

TEST SETUP

Test Freq.: 50.00 Hz. Test Voltage: 230.0 vac
Waveform : SINE Test Time: 15 min.
Classification : CLASS A Test Type: STEADY-STATE
Prog. Zo Enabled: YES Prog. Zo: 0.000
Motor Driven with Phase Angle Control: NO
Impedance selected: DIRECT
Synthetic R+L Enabled: NO
Resistance: 0.400 Ohms Inductance: 795.775 uH

TEST DATA

Result: PASS

Harmonic Current Results

Harmonic Voltage Results

Table with 8 columns: Hn, AMPS, LO Limit, HI Limit, Result, %Fund., Limit, Result. Rows 0-12 showing harmonic test results.



HomeTek Technology Inc.

13	0.000	0.315	0.315	PASS	0.003	0.100	PASS
14	0.000	0.197	0.197	PASS	0.001	0.100	PASS
15	0.001	0.225	0.225	PASS	0.001	0.100	PASS
16	0.000	0.172	0.172	PASS	0.001	0.100	PASS
17	0.000	0.199	0.199	PASS	0.001	0.100	PASS
18	0.000	0.153	0.153	PASS	0.001	0.100	PASS
19	0.000	0.178	0.178	PASS	0.002	0.100	PASS
20	0.000	0.138	0.138	PASS	0.001	0.100	PASS
21	0.000	0.161	0.161	PASS	0.002	0.100	PASS
22	0.000	0.125	0.125	PASS	0.001	0.100	PASS
23	0.000	0.147	0.147	PASS	0.003	0.100	PASS
24	0.000	0.115	0.115	PASS	0.001	0.100	PASS
25	0.000	0.135	0.135	PASS	0.003	0.100	PASS
26	0.000	0.106	0.106	PASS	0.001	0.100	PASS
27	0.000	0.125	0.125	PASS	0.003	0.100	PASS
28	0.000	0.099	0.099	PASS	0.001	0.100	PASS
29	0.000	0.116	0.116	PASS	0.001	0.100	PASS
30	0.000	0.092	0.092	PASS	0.001	0.100	PASS
31	0.000	0.109	0.109	PASS	0.002	0.100	PASS
32	0.000	0.086	0.086	PASS	0.001	0.100	PASS
33	0.000	0.102	0.102	PASS	0.003	0.100	PASS
34	0.000	0.081	0.081	PASS	0.001	0.100	PASS
35	0.000	0.096	0.096	PASS	0.002	0.100	PASS
36	0.000	0.077	0.077	PASS	0.001	0.100	PASS
37	0.000	0.091	0.091	PASS	0.001	0.100	PASS
38	0.000	0.073	0.073	PASS	0.000	0.100	PASS
39	0.000	0.087	0.087	PASS	0.002	0.100	PASS
40	0.000	0.069	0.069	PASS	0.001	0.100	PASS

PAGE 2

END OF REPORT

VOLTAGE FLUCTUATIONS TEST

1 TEST INSTRUMENTS & FACILITIES

Instruments/ facilities	Manufacturer	Model # Serial #	Date of Cal.
POWER FREQUENCY TEST SYSTEM	HAEFELY	PHF555 080419-12	JAN/2007
CONTROL PC	KB TECH	KB P586/133	N/A

2 TEST PROCEDURE

According to **EN 61000-3-3 (1995) + A1 (2001) + A2 (2005)**

3 TEST SETUP

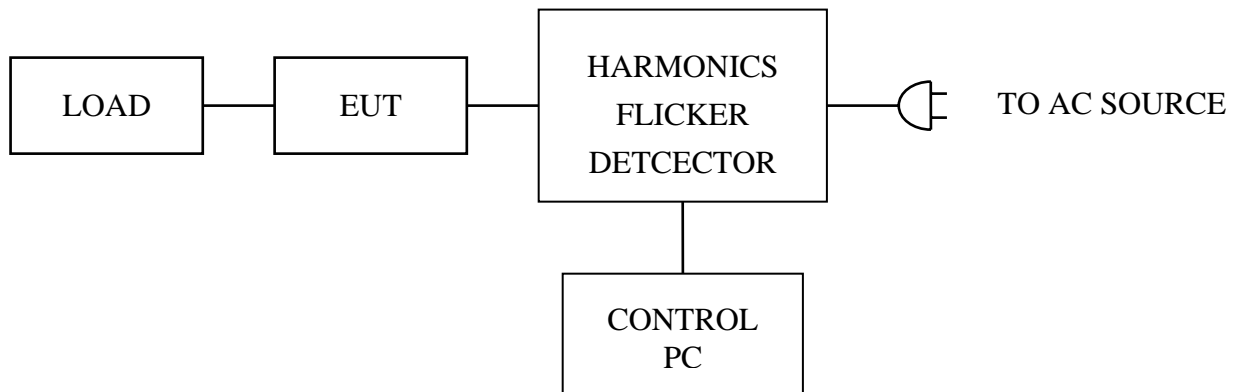

(Details for setup configuration, please refer to appendix A.)

4 CONFIGURATION OF THE EUT

Same as “Conducted Power Line test”, section 4

5 OPERATION CONDITION OF EUT

Same as “Conducted Power Line test”, section 5

6 TEST DATA & LIMIT

6.1 Temperature : 22.7 °C

6.2 Humidity : 38 % RH



7 VOLTAGE FLUCTUATIONS TEST DATA (PAGE 1)

EN61000-3-3 TEST REPORT 2007/12/04 20:36 PM

Unit : Corrector
Serial No.: VS01
Remarks : 1600 x 1200 MODE
Operator : BLINDA
=====

TEST SETUP

Test Freq.: 50.00 Hz. Test Voltage: 230.0 vac
Waveform : SINE
Test Time: 15 min. Tshort: 15 min.
Prog. Zo Enabled: YES Prog. Zo: 0.000
Voltage Change less than once per Hour: NO
Impedance selected: DIRECT
Synthetic R+L Enabled: NO
Resistance: 0.400 Ohms Inductance: 795.775 uH

TEST DATA

Result:	PASS			
	EUT Data	Limit	Result	Test Enabled
Pst max	0.010	1.00	PASS	true
Plt max	0.010	0.65	PASS	true
dc %	0.00	3.00	PASS	true
dmax %	0.00	4.00	PASS	true
d(t) sec.	0.00	0.20	PASS	true

Power Source Data

Source Pst max	0.019	0.400	PASS	true
% THD	0.02	3.00	PASS	true

PAGE 1

END OF REPORT

ELECTROSTATIC DISCHARGE IMMUNITY TEST (ESD)

1 TEST INSTRUMENTS & FACILITIES

Instruments/ Facilities	Manufacturer	Model # Serial #	Data Of Cal.
ESD TESTER	NOISEKEN	ESS-2002 ESS05033971	DEC/2006
VCP	HOMETEK	--	--

2 TEST PROCEDURE

According to **IEC 61000-4-2 (2001)**

According to **EN 55024 (1998) + A1 (2001) + A2 (2003)**

3 TEST SETUP

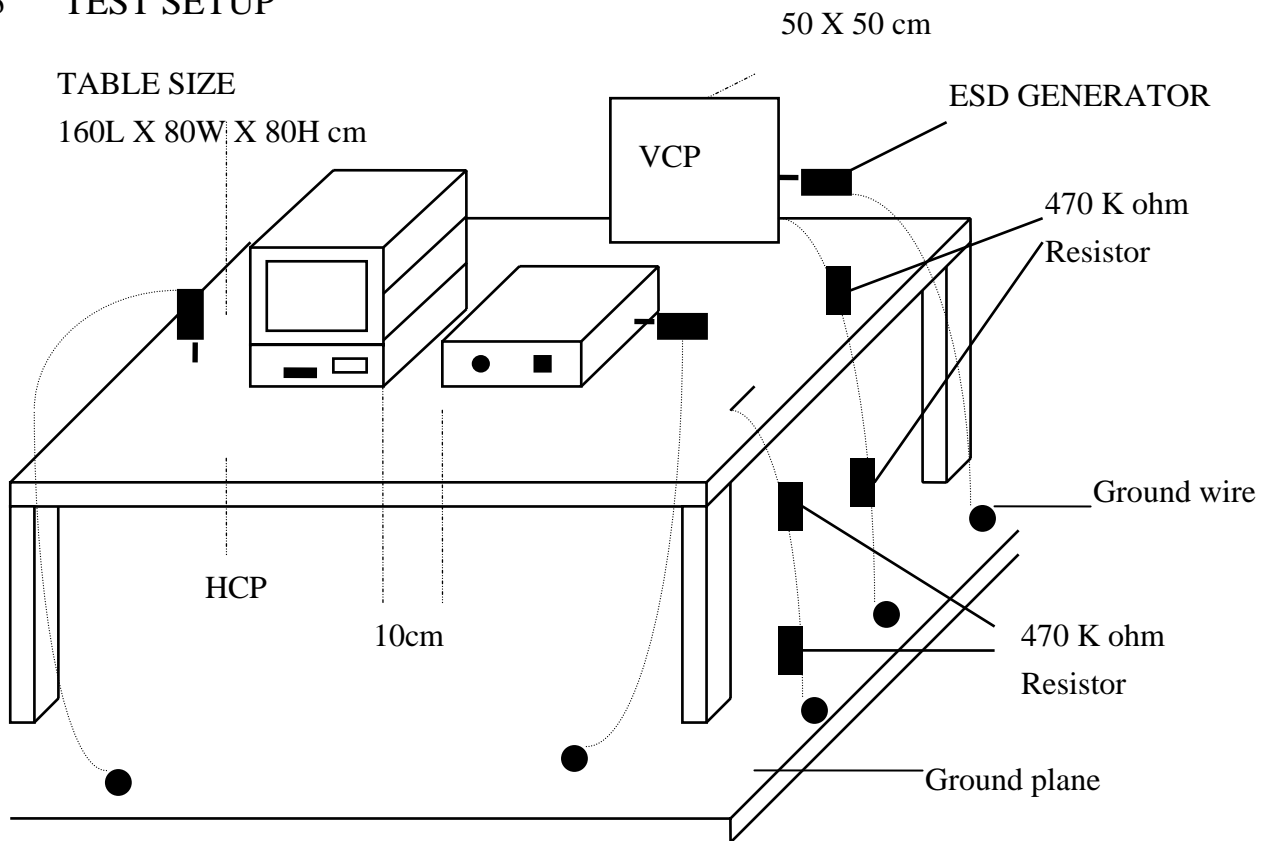

(Details for setup configuration, please refer to appendix A.)

4 CONFIGURATION OF THE EUT

Same as “Conducted Power Line test”, section 4

5 EUT OPERATION CONDITION

Same as “Conducted Power Line test”, section 5

6 TEST CONDITION

6.1 Test Level :

(A) ± 2 , ± 4 , ± 8 KV for air discharge.

(B) ± 2 , ± 4 KV for contact discharge.

6.2 Number of test : 10 Discharges / Test point / Polarity / Level

Particular requirements : at least 200 discharges, 100 each at negative and positive polarity, at a minimum of four test points.

6.3 Time between test : 1 sec.

6.4 Temperature : 22.5 °C

6.5 Humidity : 36 % RH.

7 PERFORMANCE CRITERIA

- A. The apparatus shall continue to operate as intended during and after the test. No degradation of performance or loss of function is allowed below a performance level specified by the manufacturer, when the apparatus is used as intended.
- B. The apparatus shall continue to operate as intended after the test. No degradation of performance or loss of function is allowed below a performance level specified by the manufacturer, when the apparatus is used as intended. The performance level may be replaced by a permissible loss of performance. During the test, degradation of performance is however allowed.
- C. Temporary loss of function is allowed, provided the function is self-recoverable or can be restored by the operation of the controls.

8 TEST RESULT

Test Point	Air Discharge	Contact Discharge	Performance Criteria	Result
HCP	---	$\pm 2, \pm 4KV$	B	PASSED
VCP	---	$\pm 2, \pm 4KV$	B	PASSED
CASE	$\pm 2, \pm 4, \pm 8KV$	$\pm 2, \pm 4KV$	B	PASSED
I/O PORTS	$\pm 2, \pm 4, \pm 8KV$	$\pm 2, \pm 4KV$	B	PASSED
LED	$\pm 2, \pm 4, \pm 8KV$	$\pm 2, \pm 4KV$	B	PASSED
SCREWS	$\pm 2, \pm 4, \pm 8KV$	$\pm 2, \pm 4KV$	B	PASSED
BUTTON	$\pm 2, \pm 4, \pm 8KV$	$\pm 2, \pm 4KV$	B	PASSED
POWER SWITCH	$\pm 2, \pm 4, \pm 8KV$	$\pm 2, \pm 4KV$	B	PASSED
DC SOCKET	$\pm 2, \pm 4, \pm 8KV$	$\pm 2, \pm 4KV$	B	PASSED

RADIO FREQUENCY ELECTROMAGNETIC FIELD IMMUNITY TEST (RS)

1 TEST INSTRUMENTS & FACILITIES

Item	Instruments Facilities	Manufacturer	Model # Serial #	Data Of Cal.
1	SIGNAL GENERATOR	MARCONI INSTRUMENTS	2022D 119229/010	DEC/2006
2	AMPLIFIER	KALMUS	7100LC-CE 748813-2	DEC/2006
3	FIELD SENSOR	AMPLIFIER RESEARCH	FP2000	DEC/2006
4	FIELD MONITOR	AMPLIFIER RESEARCH	FM2000	DEC/2006
5	RF VOLTMETER	BOONTON	9200C 354201AA	DEC/2006
6	RF PROBE	BOONTON	952001B 37082	DEC/2006
7	DIRECTION COUPLER	WERLATON	G2630 4795	DEC/2006
8	ANTENNA	EMCO	3810/2NM S/N:9701-1763	DEC/2006
9	CONTROL PC	KB TECH	KB P586/133	--

Note : Items 3 ~ 4 were calibrated with two years and verified before testing.

2 TEST PROCEDURE

According to **IEC 61000-4-3 (2002)**

According to **EN 55024 (1998) + A1 (2001) + A2 (2003)**

3 TEST SETUP

FERRITE TILE

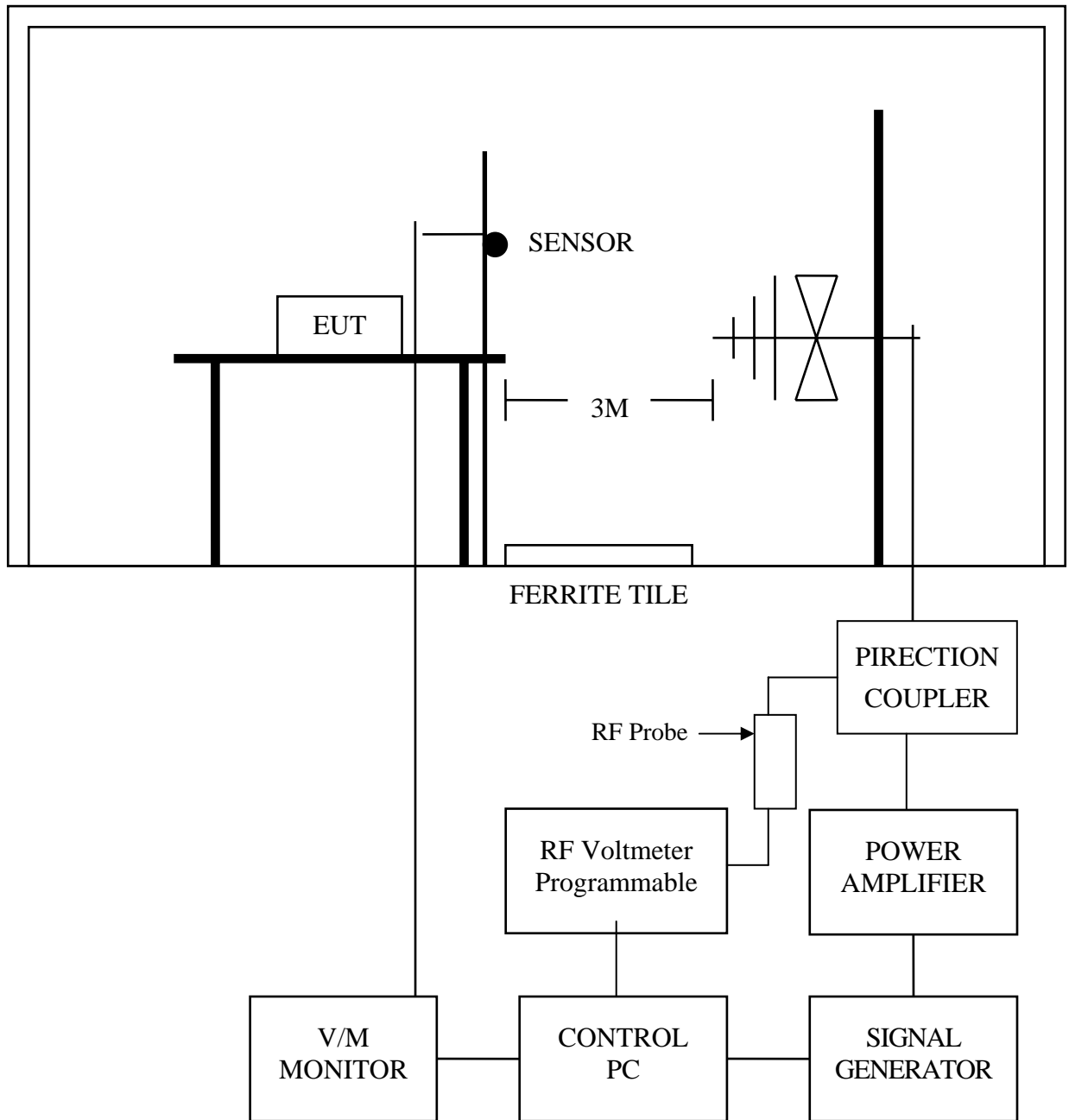

3.1 Chamber Size :

12M x 5M x 5M

(Details for setup configuration, please refer to appendix A.)

4 CONFIGURATION OF THE EUT

Same as “Conducted Power Line test”, section 4

5 OPERATION CONDITION OF EUT

Same as “Conducted Power Line test”, section 5

6 TEST CONDITION

6.1 Frequency Range : 80 MHz ~ 1000 MHz

(Frequency Range : 1.4 GHz ~ 2.0 GHz is not applicable for EN55024:1998+A1:2001+A2:2003)

6.2 Filed Strength : 3 V / M (1KHz 80% Modulation)

6.3 Frequency Step : 1 %, 3 sec. / each step size

6.4 Antenna Polarity : HORIZONTAL & VERTICAL

6.5 The four sides of EUT are tested
(FRONT, REAR, RIGHT, LEFT)

6.6 Temperature : 22.7 °C

6.7 Humidity : 37 % RH

7 PERFORMANCE CRITERIA

- A. The apparatus shall continue to operate as intended during and after the test. No degradation of performance or loss of function is allowed below a performance level specified by the manufacturer, when the apparatus is used as intended.
- B. The apparatus shall continue to operate as intended after the test. No degradation of performance or loss of function is allowed below a performance level specified by the manufacturer, when the apparatus is used as intended. The performance level may be replaced by a permissible loss of performance. During the test, degradation of performance is however allowed.
- C. Temporary loss of function is allowed, provided the function is self-recoverable or can be restored by the operation of the controls.

8 TEST RESULT

ANT SIDE	HORIZONTAL	VERTICAL	RESULT
FRONT	A	A	PASSED
REAR	A	A	PASSED
RIGHT	A	A	PASSED
LEFT	A	A	PASSED

ELECTRICAL FAST TRANSIENT/BURST IMMUNITY TEST (EFT)

1 TEST INSTRUMENTS & FACILITIES

Instruments/ Facilities	Manufacturer	Model # Serial #	Data Of Cal.
BURST-TESTER	EMC PARTNER	TRANSIENT-1000 TRA1000-317	DEC/2006
CONTROL PC	KB TECH	KB P586/133	--

2 TEST PROCEDURE

According to **IEC 61000-4-4 (2004)**

According to **EN 55024 (1998) + A1 (2001) + A2 (2003)**

3 TEST SETUP

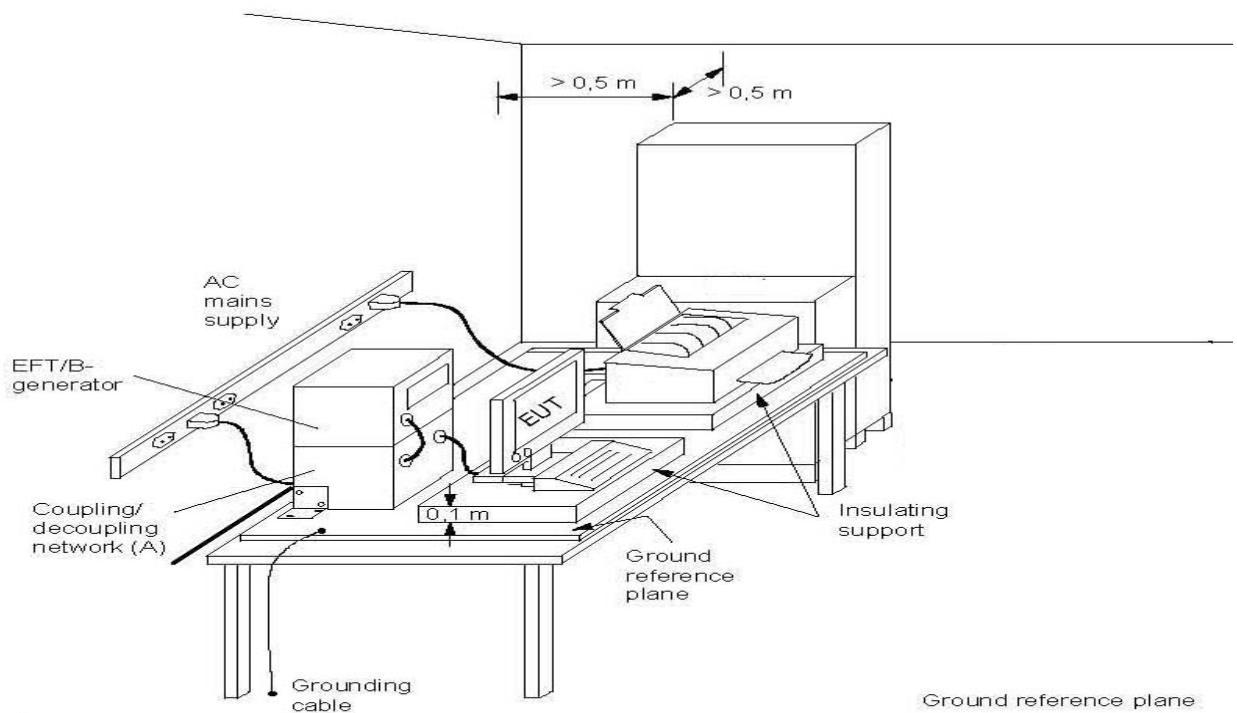

(Details for setup configuration, please refer to appendix A.)

Note: length between clamp and the EUT to be tested (should be $0.5 \text{ m} \pm 0.05 \text{ m}$)

(A) location for supply line coupling

(B) location for signal line coupling

4 CONFIGURATION OF THE EUT

Same as “Conducted Power Line test”, section 4

5 OPERATION CONDITION OF EUT

Same as “Conducted Power Line test”, section 5

6 TEST CONDITION

6.1 Pulse Rise time & Duration : 5 nS / 50 nS

6.2 Pulse Repetition : 5 kHz

6.3 Polarity : POSITIVE / NEGATIVE

6.4 Test Voltage : $\pm 0.5\text{KV}$, $\pm 1\text{KV}$

6.5 Coupling of power line :
L, N, L+N

6.6 Temperature : 22.3 °C

6.7 Humidity : 39 % RH

7 PERFORMANCE CRITERIA

- A. The apparatus shall continue to operate as intended during and after the test. No degradation of performance or loss of function is allowed below a performance level specified by the manufacturer, when the apparatus is used as intended.
- B. The apparatus shall continue to operate as intended after the test. No degradation of performance or loss of function is allowed below a performance level specified by the manufacturer, when the apparatus is used as intended. The performance level may be replaced by a permissible loss of performance. During the test, degradation of performance is however allowed.
- C. Temporary loss of function is allowed, provided the function is self-recoverable or can be restored by the operation of the controls.

8 TEST RESULT

TEST VOLTAGE	L	N	L+N
$\pm 0.5\text{KV}$	A	A	A
$\pm 1\text{KV}$	A	A	A

8.1 Model : VS018.2 Test Mode : 1600 x 1200 MODE8.3 Final Result : PASSED

8.4 Remark :

SURGE IMMUNITY TEST

1 TEST INSTRUMENTS & FACILITIES

Instruments/ Facilities	Manufacturer	Model # Serial #	Data Of Cal.
BURST-TESTER	EMC PARTNER	TRANSIENT-1000 TRA1000-317	DEC/2006
CONTROL PC	KB TECH	KB P586/133	--

2 TEST PROCEDURE

According To **IEC 61000-4-5 (2001)**

According To **EN 55024 (1998) + A1 (2001) + A2 (2003)**

3 TEST SETUP

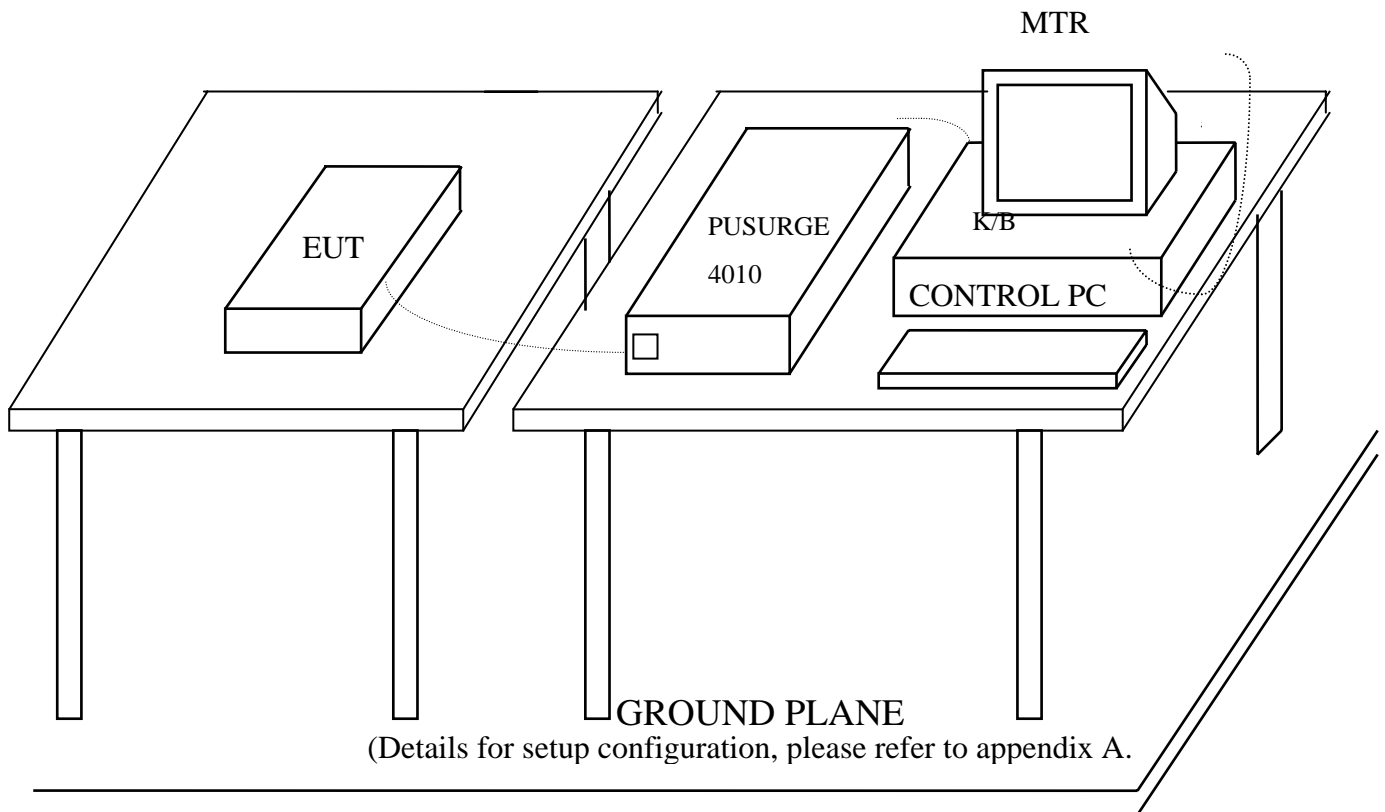

4 TEST LEVELS

- Input and Output AC Power Ports.
- DC Input and DC Output Power Ports.

Environmental Phenomena	Test Specification		Units	Performance Criteria
	AC	DC		
Surges	1.2 / 50 (8/20)		Tr /Th us	
Line to Line	±1	±0.5	KV (Charge Voltage)	B

5 CONFIGURATION OF THE EUT

Same as “Conducted Power Line test”, section 4

6 EUT OPERATION CONDITION

Same as “Conducted Power Line test”, section 5

7 CONDITIONS DURING TESTING

7.1 Coupling of power line :

(A) Line to Line ±1KV (AC) or ±0.5KV (DC)

7.2 Polarity : POSITIVE / NEGATIVE

7.3 Phase shifting in a range between 0° to 360°

7.4 Repletion rate at least 1 per min

7.5 Temperature : 23.1 °C (15°C ~ 35°C)

Humidity : 40 % RH.(10 % ~ 75%)

8 PERFORMANCE CRITERIA

- A. The apparatus shall continue to operate as intended during and after the test. No degradation of performance or loss of function is allowed below a performance level specified by the manufacturer, when the apparatus is used as intended.
- B. The apparatus shall continue to operate as intended after the test. No degradation of performance or loss of function is allowed below a performance level specified by the manufacturer, when the apparatus is used as intended. The performance level may be replaced by a permissible loss of performance. During the test, degradation of performance is however allowed.
- C. Temporary loss of function is allowed, provided the function is self-recoverable or can be restored by the operation of the controls.

9 TEST RESULT

Environmental Phenomena	Test Specification	Units	Performance
Line to Line	± 1	KV (Charge Voltage)	A

9.1 Model : VS01

9.2 Test Mode : 1600 x 1200 MODE

9.3 Final Result : PASSED

9.4 Remark :

IMMUNITY TEST TO CS CONDUCTED DISTURBANCE

1 TEST INSTRUMENTS & FACILITIES

Instruments/ Facilities	Manufacturer	Model # Serial #	Date Of Cal.
SIGNAL GENERATOR	MARCONI INSTRUMENTS	2022D 119229/010	DEC/2006
AMPLIFIER	KALMUS	7100LC-CE	DEC/2006
RF VOLTMETER	BOONTON	9200C 354201AA	DEC/2006
RF PROBE	BOONTON	952001B 37082	DEC/2006
DIRECTION COUPLER	WERLATON	G2630 4795	DEC/2006
COUPLING DECOUPLING NETWORK	ELECTRO-METRICS	EM-7801 103	DEC/2006
CONTROL PC	KB TECH	KB P586/133	--

2 TEST PROCEDURE

According To **IEC 61000-4-6 (2003) + A1 (2004)**

According To **EN 55024 (1998) + A1 (2001) + A2 (2003)**

3 TEST SETUP

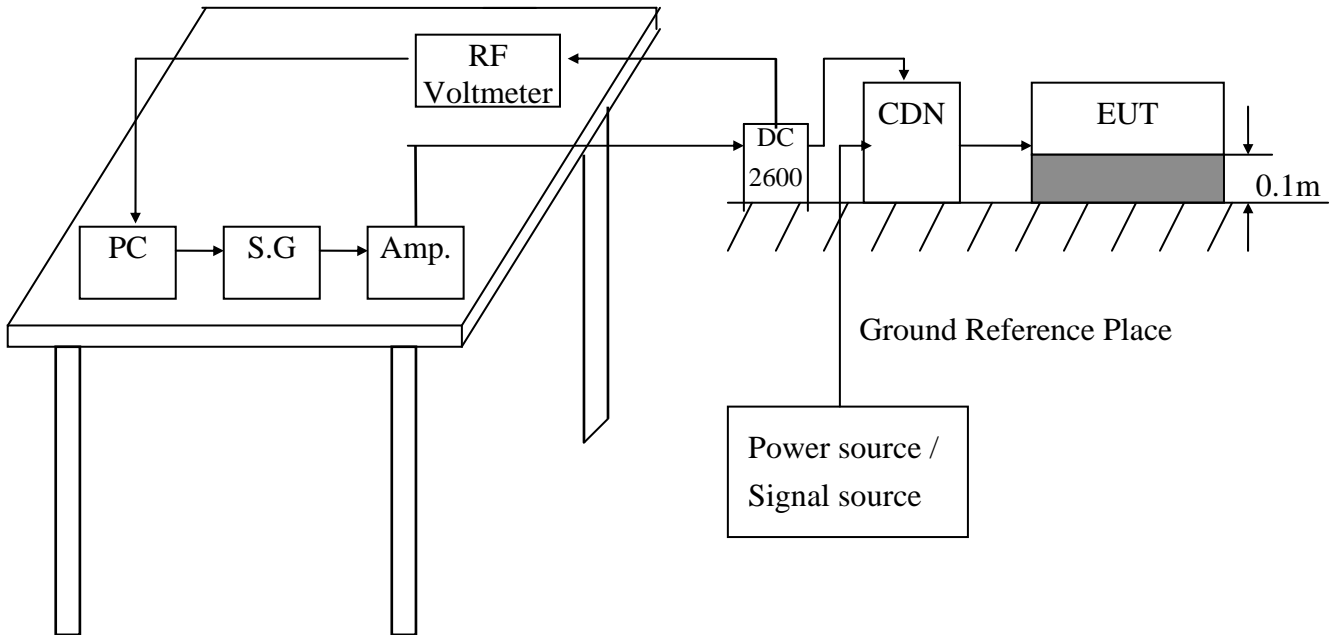

(Details for setup configuration, please refer to appendix A.)

4 TEST LEVELS

- Ports for signal lines and control lines.
- DC input and DC output power ports.
- Input and Output AC Power Ports.
- Functional earth Ports.

Environmental	Test Specification	Units	Performance
Radio-frequency	0.15 - 80	MHz	
Common mode	3	V	A
	80	% AM (1KHz)	

5 CONFIGURATION OF THE EUT

Same as “Conducted Power Line test”, section 4

6 EUT OPERATION CONDITION

Same as “Conducted Power Line test”, section 5

7 CONDITIONS DURING TESTING

7.1 The EUT tested type :

- Single unit
- Multiple unit

7.2 Dwell time : < 1%

7.3 Temperature : 23.4 °C (15°C ~ 35°C)

Humidity : 39 % RH.(10 % ~ 75%)

8 PERFORMANCE CRITERIA

- A. The apparatus shall continue to operate as intended during and after the test. No degradation of performance or loss of function is allowed below a performance level specified by the manufacturer, when the apparatus is used as intended.
- B. The apparatus shall continue to operate as intended after the test. No degradation of performance or loss of function is allowed below a performance level specified by the manufacturer, when the apparatus is used as intended. The performance level may be replaced by a permissible loss of performance. During the test, degradation of performance is however allowed.
- C. Temporary loss of function is allowed, provided the function is self-recoverable or can be restored by the operation of the controls.

9 TEST RESULT

TEST Specification	Unit	Performance Criteria
0.15 - 80	MHz	A
3	V	
80	% AM (1KHz)	

9.1 Model : VS01

9.2 Test Mode : 1600 x 1200 MODE

9.3 Final Result : PASSED

9.4 Remark :

POWER FREQUENCY MAGNETIC FIELD IMMUNITY TEST

1 TEST INSTRUMENTS & FACILITIES

Instruments/ Facilities	Manufacturer	Model # Serial #	Data Of Cal.
LINE INTERFERENCE TESTER	HAEFELY	PLINE 1610 080166-10	DEC/2006
MAGNETIC FIELD TESTER	HAEFELY	MAG 100.1 080206-01	DEC/2006
TRIAXIAL ELF MAGNETIC FIELD METER	F.W.BELL	4080 9645	DEC/2006
CONTROL PC	KB TECH	KB P586/133	--

2 TEST STANDARD

According To **IEC 61000-4-8 (2001)**

According To **EN 55024 (1998) + A1 (2001) + A2 (2003)**

3 TEST SETUP

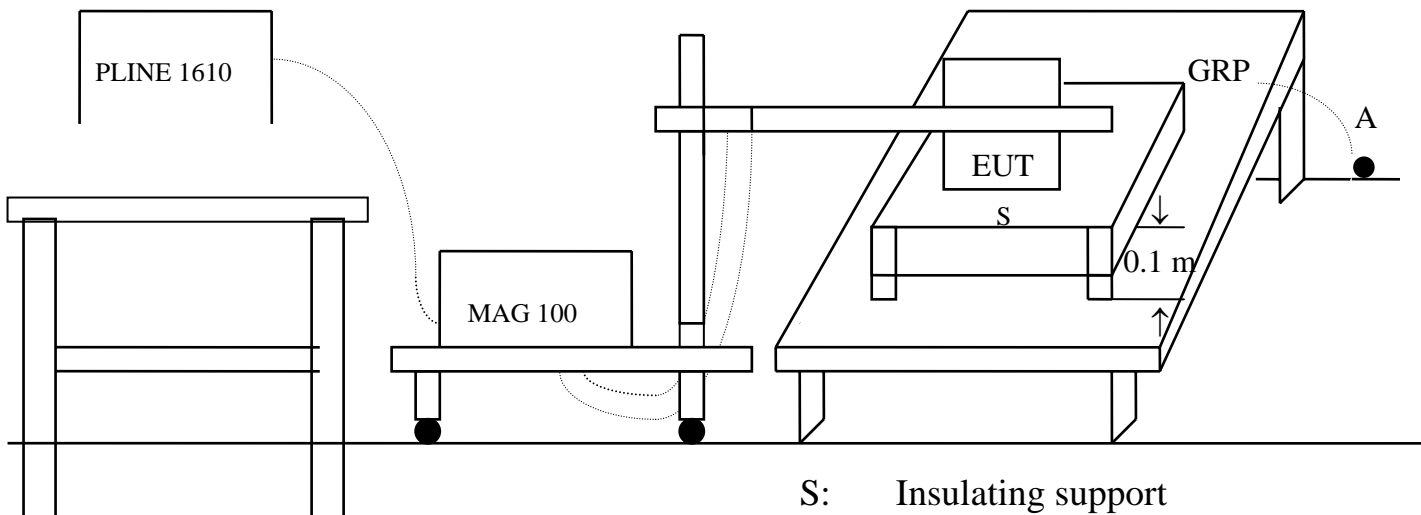

S: Insulating support
A: Safety earth
GRP: Ground plane

(Details for setup configuration, please refer to appendix A.)

4 TEST LEVELS

Environmental Phenomena	Test Specification	Units	Performance Criteria
Power Frequency	50	HZ	
Magnetic Field	1	A/m	B

5 CONFIGURATION OF THE EUT

Same as “Conducted Power Line test”, section 4

6 OPERATION CONDITION OF EUT

Same as “Conducted Power Line test”, section 5

7 CONDITIONS DURING TESTING

7.1 Temperature : 22.7 °C (15°C ~ 35°C)

Humidity : 38 % RH.(25 % ~ 75%)

7.2 The induction coil shall be rotated by 90°

8 PERFORMANCE CRITERIA

- A. The apparatus shall continue to operate as intended during and after the test. No degradation of performance or loss of function is allowed below a performance level specified by the manufacturer, when the apparatus is used as intended.
- B. The apparatus shall continue to operate as intended after the test. No degradation of performance or loss of function is allowed below a performance level specified by the manufacturer, when the apparatus is used as intended. The performance level may be replaced by a permissible loss of performance. During the test, degradation of performance is however allowed.
- C. Temporary loss of function is allowed, provided the function is self-recoverable or can be restored by the operation of the controls.

9 TEST RESULTS

Environmental Phenomena	Test Specification	Units	Performance Criteria
Magnetic Field	1	A/m	A

9.1 Model : VS01

9.2 Test Mode : 1600 x 1200 MODE

9.3 Final Results : PASSED

9.4 Remark :

VOLTAGE DIPS, SHORT INTERRUPTIONS IMMUNITY TEST

1 TEST INSTRUMENTS & FACILITIES

Instruments/ Facilities	Manufacturer	Model # Serial #	Data Of Cal.
LINE INTERFERENCE -TESTER	EMC PARTNER	TRANSIENT-1000 TRA1000-317	DEC/2006
CONTROL PC	KB TECH	KB P586/133	--

2 TEST PROCEDURE

According To **IEC 61000-4-11 (2004)**

According To **EN 55024 (1998) + A1 (2001) + A2 (2003)**

3 TEST SETUP

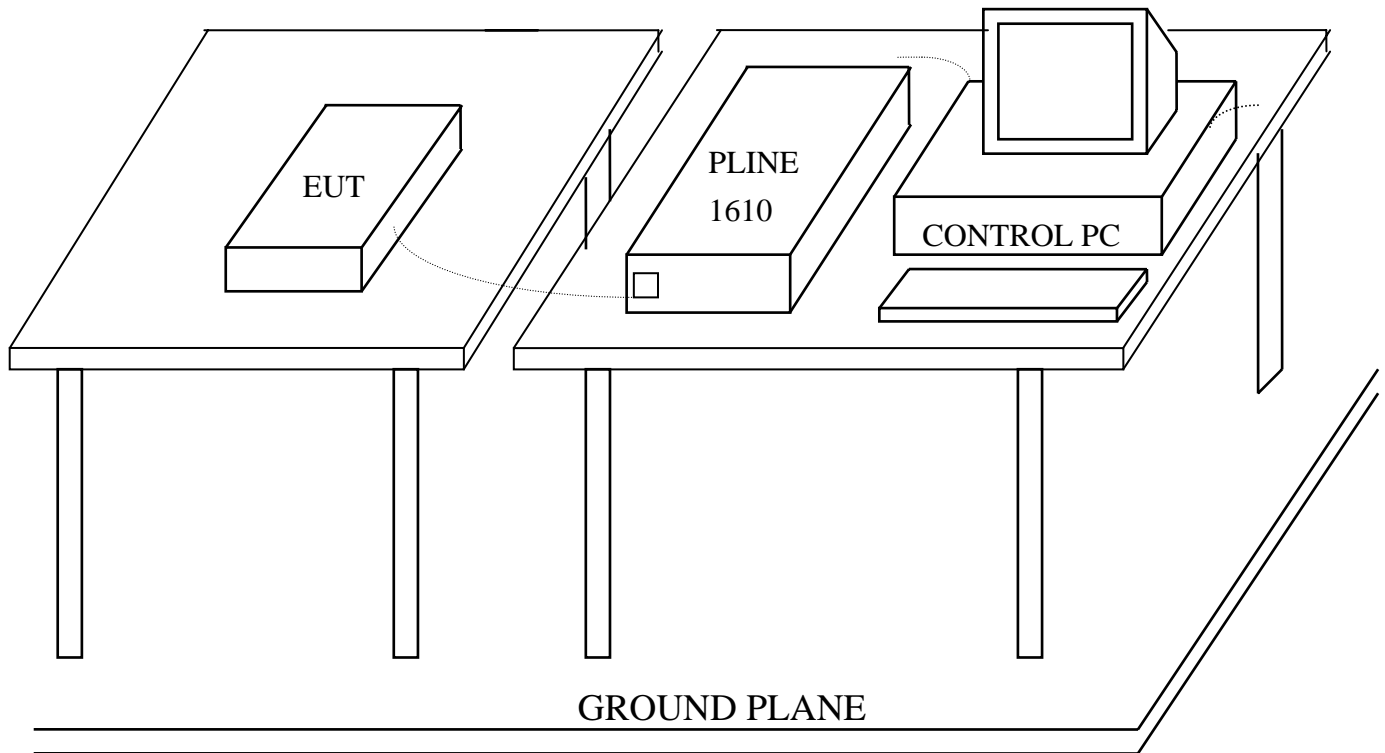

(Details for setup configuration, please refer to appendix A.)

4 TEST LEVELS

Input and Output AC Power Ports.

- Voltage Dips.
- Voltage Interruptions.

Class ^a	Test level and durations for voltage dips				
Class 1	Case-by-case according to the equipment requirements				
Class 2	0 % during 1/2 cycle	0 % during 1 cycle	70 % during 25/30 ^c cycles		
Class 3	0 % during 1/2 cycle	0 % during 1 cycle	40 % during 10/12 ^c cycles	70 % during 25/30 ^c cycles	80 % during 250/300 ^c cycles
a: Classes as per IEC 61000-2-4. b: To be defined by product committee. For equipment connected directly or indirectly to the public network, the levels must not be less severe than Class 2. c: “25/30 cycles” means “25 cycles for 50 Hz test” and “30 cycles for 60 Hz tet”.					

Class ^a	Test level and durations for short interruptions (t _s) (50Hz / 60Hz)
Class 1	Case-by-case according to the equipment requirements
Class 2	0 % during 250/300 ^c cycles
Class 3	0 % during 250/300 ^c cycles
Class X ^b	X
a: Classes as per IEC 61000-2-4. b: To be defined by product committee. For equipment connected directly or indirectly to the public network, the levels must not be less severe than Class 2. c: “250/300 cycles” means “250 cycles for 50 Hz test” and “300 cycles for 60 Hz test”.	

✘ **According to the specification of EUT, Class 2 is applied.**

5 CONFIGURATION OF THE EUT

Same as “Conducted Power Line test”, section 4

6 EUT OPERATION CONDITION

Same as “Conducted Power Line test”, section 5

7 CONDITIONS DURING TESTING

7.1 Temperature : 23.1 °C (15°C ~ 35°C)

Humidity : 39 % RH.(25 % ~ 75%)

8 PERFORMANCE CRITERIA

- A. The apparatus shall continue to operate as intended during and after the test. No degradation of performance or loss of function is allowed below a performance level specified by the manufacturer, when the apparatus is used as intended.
- B. The apparatus shall continue to operate as intended after the test. No degradation of performance or loss of function is allowed below a performance level specified by the manufacturer, when the apparatus is used as intended. The performance level may be replaced by a permissible loss of performance. During the test, degradation of performance is however allowed.
- C. Temporary loss of function is allowed, provided the function is self-recoverable or can be restored by the operation of the controls.

9 TEST RESULT

Environmental Phenomena	Test Specification	Units	Perform Criteria
Voltage Dips	0 1/2	% during Cycle	B
	0 1	% during Cycle	B
	70 25	% during Cycles	C
Voltage Short Interruptions	0 250	% during Cycles	C

9.1 Model : VS01

9.2 Test Mode : 1600 x 1200 MODE

9.3 Final Results : PASSED

9.4 Remark :



HomeTek Technology Inc.

Appendix A

PHOTOS OF TEST CONFIGURATION

PHOTO OF CONDUCTED POWER LINE TEST



Front View

PHOTO OF RADIATED EMISSION TEST



Front View



HomeTek Technology Inc.

Appendix B

PHOTOS OF EUT

PHOTO OF EUT



Front View of EUT

Rear View of EUT



Inside View of EUT



Full View of Adapter

Declaration of Conformity

We(Manufacturer/Importer)

(company name)

(address)

declares under our sole responsibility that the product

Product name : Corrector

Model No. : XX01X

to which this declaration relates is in conformity with the following standard(s) or other normative document(s)

- | | |
|---|---|
| <input checked="" type="checkbox"/> EN 55022 Class B (1998) | <input checked="" type="checkbox"/> EN 55024 (1998) |
| + A1 (2000) | + A1 (2001) |
| + A2 (2003) | + A2 (2003) |
| <input checked="" type="checkbox"/> EN 61000-3-2 (2006) | <input checked="" type="checkbox"/> IEC 61000-4-2 (2001) |
| <input checked="" type="checkbox"/> EN 61000-3-3 (1995) | <input checked="" type="checkbox"/> IEC 61000-4-3 (2002) |
| + A1 (2001) | <input checked="" type="checkbox"/> IEC 61000-4-4 (2004) |
| + A2 (2005) | <input checked="" type="checkbox"/> IEC 61000-4-5 (2001) |
| | <input checked="" type="checkbox"/> IEC 61000-4-6 (2003) |
| | + A1 (2004) |
| | <input checked="" type="checkbox"/> IEC 61000-4-8 (2001) |
| | <input checked="" type="checkbox"/> IEC 61000-4-11 (2004) |

following the provisions of 2004/108/EC Directive

Place: _____ Signature: _____

Date : _____ Full name: _____



Title: _____



TÜV Rheinland Taiwan Ltd.

Certificate of Appointment

for the applicant:

Hometek Technology Inc.
No. 67-9, Shir Men Rd., Tu-Cheng City,
Taipei Hsien 236, Taiwan, R.O.C.

has been authorized to carry out EMC tests by order and under supervision of TÜV Rheinland. It has successfully demonstrated capability to conduct measurement and to process test data according to:

**European and International EMC Standards as listed in the
Scope of Authorization on the attachment to this certificate**

An assessment of the facility was conducted by TÜV Rheinland auditors according to the TÜV Rheinland requirements for "Test Site Approval" with reference to

ISO 17025: 2005

Certificate No. : 10012161-2007

Valid until : Sept. 7, 2008

TÜV Rheinland Taiwan Ltd.
Taipei, June 20, 2007

Dipl.-Ing. Andreas Klinker
Certification Body

Dipl.-Ing. Bodo Kretzschmar
Product Safety and Quality



Attachment to
Certificate
of Appointment

SCOPE OF AUTHORIZATION

Hometek Technology Inc.
No. 67-9, Shir Men Rd., Tu-Cheng City,
Taipei Hsien 236, Taiwan, R.O.C.

European Standards

EN 50081-1	EN 61000-3-3	ENV 50140
EN 50081-2	EN 61000-6-1	ENV 50141
EN 50082-1	EN 61000-6-2	ENV 50204
EN 50130-4	EN 61000-6-3	
EN 50091-2	EN 61000-6-4	
EN 55011	EN 61000-3-11	
EN 55013	EN 61000-4-2	
EN 55014-1	EN 61000-4-3	
EN 55014-2	EN 61000-4-4	
EN 55022	EN 61000-4-5	
EN 55024	EN 61000-4-6	
EN 60601-1-2	EN 61000-4-8	
EN 60801	EN 61000-4-11	
EN 60945	EN 61204-3	
EN 61000-3-2	EN 62040-2	

International Standards

CISPR 11	IEC 61000-4-2	IEC 61000-3-2
CISPR 13	IEC 61000-4-3	IEC 61000-3-3
CISPR 14-1	IEC 61000-4-4	IEC 61000-3-11
CISPR 14-2	IEC 61000-4-5	IEC 61000-6-1
CISPR 22	IEC 61000-4-6	IEC 61000-6-2
CISPR 24	IEC 61000-4-8	IEC 61000-6-3
	IEC 61000-4-11	IEC 61000-6-4
IEC 801.2	IEC 61000-4-12	IEC 60945
IEC 801.3		IEC 62040-2
IEC 801.4		

Certificate No. : 10012161-2007

Taipei, June 20, 2007

Dipl.-Ing. Bodo Kretzschmar
Product Safety and Quality