



EMC COMPLIANCE TEST REPORT

Technical Statement of Conformity
in accordance with the council directive 2004/108/EC

The product

Equipment Under Test	: Component Video & Stereo Audio, Digital CAT5 Extender With Chainable Output
Model Number	: YEXXDALX
Product Series	: N/A
Report Number	: HA110542-CE
Issue Date	: 13-DEC-2011
Test Result	: Compliance

is produced by

SMART HOME ENGINEERING CORP.

10F, No.493, Chung-Cheng Rd., Hsin Tien Dist., New Taipei City, 231, Taiwan



HongAn TECHNOLOGY CO., LTD.

NO.15-1, CWEISHUH KENG, CWEIPIN VILLAGE,
LINKOU DIST., NEW TAIPEI CITY,
TAIWAN, R. O. C.

TEL: +886-2-26030362

FAX: +886-2-26019259

E-mail: hatlab@ms19.hinet.net

BSMI Registration No. : SL2-IN-E-0023, SL2-A1-E-0023,
SL2-IS-E-0023, SL2-R1-E-0023,
SL2-R2-E-0023, SL2-L1-E-0023

Nemko Authorization No. : ELA184

TAF Accreditation No. : 1163

VCCI Registration No. : R-2156, C-2329, T-219

FCC Designation No. : TW1001

Contents

1	General Description	6
1.1	Description of EUT	6
1.2	Test Instruments	8
1.3	Auxiliary Equipments	10
1.4	EUT SETUP	10
1.5	Identifying the Final Test Mode	11
1.6	Final Test Mode	11
1.7	Condition of Power Supply	11
1.8	EUT Configuration	11
1.9	Qualification of Test Facility	11
2	Conducted Disturbance Emission Test	12
2.1	Test Instruments	12
2.2	Test Arrangement and Procedure	12
2.3	Conducted Disturbance Limit	13
2.4	Test Result	13
3	Radiated Disturbance Emission Test	16
3.1	Test Instruments	16
3.2	Test Arrangement and Procedure	16
3.3	Radiated Disturbance Limit	17
3.4	Test Result	17
4	Harmonic Current Emission Measurement	20
4.1	Test Instruments	20
4.2	Test Configuration and Procedure	20
4.3	EUT Operation Condition	21
4.4	Test Limit	21
4.5	Test Result	21
5	Voltage Fluctuations and Flicker Measurement	23
5.1	Test Instruments	23
5.2	Test Configuration and Procedure	23
5.3	EUT Operation Condition	23
5.4	Test Limit	23
5.5	Test Result	23
6	Electrostatic Discharge Immunity Test	25
6.1	Test Instruments	25
6.2	Test Configuration and Procedure	25

6.3	Test Result	26
7	Radio-frequency, Electromagnetic Field Immunity Test	27
7.1	Test Instruments	27
7.2	Test Configuration and Procedure	27
7.3	Test Result	28
8	Electrical Fast Transient Test	29
8.1	Test Instrument	29
8.2	Test Configuration and Procedure	29
8.3	Test Result	30
9	Surge Immunity Test	31
9.1	Test Instrument	31
9.2	Test Configuration and Procedure	31
9.3	Test Result	32
10	Radio-frequency, Conducted Disturbances Immunity Test	33
10.1	Test Instruments	33
10.2	Test Configuration and Procedure	33
10.3	Test Result	34
11	Power Frequency Magnetic Field Immunity Test	35
11.1	Test Instruments	35
11.2	Test Configuration and Procedure	35
11.3	Test Result	36
12	Voltage Dips, Short Interruptions Immunity Test	37
12.1	Test Instrument	37
12.2	Test Configuration and Procedure	37
12.3	Test Result	38
13	Photographs of the Tests	39
13.1	Conducted Disturbance Emission Test	39
13.2	Radiated Disturbances Emission Test	40
13.3	Harmonic Current Emission Test & Voltage Fluctuation and Flicker Emission Test	41
13.4	Electrostatic Discharge Immunity Test	41
13.5	Radio-frequency, Radio-frequency, Electromagnetic Field Immunity Test	42
13.6	Electrical Fast Transient / Burst Immunity Test	42
13.7	Surge Immunity Test	43
13.8	Conducted Disturbances Test, Induced by Radio-frequency Field Immunity Test	43
13.9	Power Frequency Magnetic Field Immunity Test	44
13.10	Voltage Dips, Short Interruptions and Voltage Variations Immunity Test	44
14	Photographs of the EUT	45

Verification

Applicant : SMART HOME ENGINEERING CORP.

Address of Applicant : 10F, No.493, Chung-Cheng Rd., Hsin Tien Dist., New Taipei City, 231, Taiwan

Manufacturer : SMART HOME ENGINEERING CORP.

Address of Manufacturer : 10F, No.493, Chung-Cheng Rd., Hsin Tien Dist., New Taipei City, 231, Taiwan

Equipment Under Test : Component Video & Stereo Audio, Digital CAT5 Extender With Chainable Output

Model Number : YEXXDALX

Product Series : N/A

Sample Received Date : 02-DEC-2011

Test Standard :

Emission :	Immunity :
<input checked="" type="checkbox"/> EN 55022:2006/A2:2010 Class B	<input checked="" type="checkbox"/> EN 55024:2010
<input checked="" type="checkbox"/> EN 61000-3-2:2006/A1:2009+A2:2009	<input checked="" type="checkbox"/> EN 61000-4-2:2009
<input checked="" type="checkbox"/> EN 61000-3-3:2008	<input checked="" type="checkbox"/> EN 61000-4-3:2006/A2:2010
	<input checked="" type="checkbox"/> EN 61000-4-4:2004/A1:2010
	<input checked="" type="checkbox"/> EN 61000-4-5:2006
	<input checked="" type="checkbox"/> EN 61000-4-6:2009
	<input checked="" type="checkbox"/> EN 61000-4-8:2010
	<input checked="" type="checkbox"/> EN 61000-4-11:2004

Deviations from standard test methods & any other specifications : NONE

Remark :

This report details the results of the test carried out on one sample. This report applies to the above sample only and shall not be reproduced in part without written approval of HongAn Technology Co. Ltd.

Joe Chen.

Documented by : _____
Zoe Chen / ADM. Dept Staff

M.S.Shi

Tested by : _____
M.S.SHI / ENG. Dept. Staff

Peter Chin

Approved by : _____
Peter Chin / Section Manager

Date : 2011-12-13

Summary of Test Result

Emission			
Test Standard	Test Item	Test Result	Remark
EN55022 Class B	Conducted Disturbance	Compliance	Highest Emission: Neutral: 10.53 MHz, 36.76 dBuV (Average) Margin -13.24 dB.
EN55022 Class B	Radiated Disturbances	Compliance	Highest Emission: Vertical: 36.21 MHz, 26.84 dBuV (Quasi-Peak), Margin -3.16 dB, Antenna Height 100 cm, Turntable Angle 56°.
EN61000-3-2	Harmonic Current Emission	Compliance	Refer to Page 21
EN61000-3-3	Voltage Fluctuation and Flicker Emission	Compliance	Refer to Page 23

Immunity				
Test Standard	Test Item	Performance Criteria	Observed Result Class	Test Result
EN61000-4-2	Electrostatic Discharge Immunity	B	B	Compliance
EN61000-4-3	Radio-frequency, Radio-frequency, Electromagnetic Field Immunity	A	A	Compliance
EN61000-4-4	Electrical Fast Transient / Burst Immunity	B	B	Compliance
EN61000-4-5	Surge Immunity	B	B	Compliance
EN61000-4-6	Conducted Disturbances Test, Induced by Radio-frequency Field	A	A	Compliance
EN61000-4-8	Power Frequency Magnetic Field Immunity	A	A	Compliance
EN61000-4-11	Voltage Dips, Short Interruptions and Voltage Variations Immunity	Dips >95% B	B	Compliance
		Dips 30% C	C	
		Interruptions >95% C	C	



	<p>Each set including one piece YEXXDALT transmitter and one piece YEXXDALR receiver.</p> <p>Support analog stereo audio and digital audio.</p> <p>Digital transmission on analog stereo audio for sound undistorted. (Dolby Digital, AC3, DTS passed through)</p> <p>Supports hi resolution up to 1080p.</p> <p>Long range transmission up to 300 meters (Max.)</p> <p>Dual output: 1 Component Video loop output for local, plus 1 x CAT5 RJ45 output for remote side.</p> <p>Built in equalization, gain adjustment, chainable CAT5 output at remote unit.</p> <p>Remote unit could be daisy chained to another YEXXDALR receiver to extended working range over 300 meters and multiple displays.</p> <p>Application for airports, train & bus stations, window display, trades shows, exhibitions.</p> <p>※For more detail specification, please refer to the User Manual.</p>
--	---

1.2 Test Instruments

1.2.1. Instruments Used for Emission Measurement

Instrument Name	Manufacture Mode	Model Number	Serial Number	Last Cal. Date	Next Cal. Date	Test Item
LISN	EMCO	3810/2NM	9702-1820	30-Sep-2011	29-Sep-2012	Conducted Emission
LISN	Rolf Heine Hochfrequenz technik	NNB-4/32T	00001	17-FEB-2011	17-FEB-2012	Conducted Emission
RF Current Probe	FCC	F-33-4	53	02-MAY-2011	01-MAY-2012	Conducted Emission
Impedance Stabilization Network (ISN)	SCHAFFNER	ISN T400	16832	08-OCT-2011	08-OCT-2012	Conducted Emission
EMI Test Signal Analyzer	PMM	PMM 9000	4410J10302	05-AUG-2011	04-AUG-2012	Conducted Emission, Radiation Emission
Spectrum Analyzer	ADVANTEST	R3172	101202158	15-AUG-2011	14-AUG-2012	Radiated Emission
Preamplifier	CHASE	CPA 9231A	3310	08-JUL-2011	07-JUL-2012	Radiated Emission
Preamplifier	HD	HD17187	004	23-Aug-2011	22-Aug-2012	Radiated Emission
Bilog Antenna	CHASE	CBL 6112B	2860	17-AUG-2011	16-AUG-2012	Radiated Emission
Double-Ridged Waveguide Horn	EMCO	3115	9912-5992	02-MAY-2011	01-MAY-2012	Radiated Emission
Harmonics /Flicker Module	EMC PARTNER	Harmonics-1000	HAR1000-38	25-FEB-2011	25-FEB-2012	Harmonics

※ The test equipments used are calibrated and can be traced to National ITRI and International Standards.

1.2.2. Instruments Used for Immunity Measurement

Instrument Name	Manufacture Mode	Model Number	Serial Number	Last Cal. Date	Next Cal. Date	Test Item
ESD Simulator	KeyTek	MZ-15/EC	9805460	12-JUN-2011	11-JUN-2012	ESD
Power Generator, Mains Coupler/ Decoupler	KeyTek	EMC Pro	0002255	02-MAR-2011	01-MAR-2012	EFT. Surge, Magnetic Field, Dip
Wide Band Amplifier	ifi	CMX50	D019-0200	25-FEB-2011	25-FEB-2012	RS
RF Amplifier	ar	15S1G3	306578	02-AUG-2011	02-AUG-2012	RS
Double-Ridged Waveguide Horn	EMCO	3115	9912-5992	02-MAY-2011	01-MAY-2012	RS
Signal Generator	HP	HP8648C	3623A03457	19-JAN-2011	19-JAN-2012	RS
Bilog Antenna	EMCO	3142	9710-1221	11-JAN-2011	11-JAN-2012	RS
CDN	FCC	FCC-801-M3-32A	2019	19-JAN-2011	19-JAN-2012	CS
CDN	FCC	FCC-801-M3-32A	20116	19-JAN-2011	19-JAN-2012	CS
EM Injection clamp	FCC	F-2031-23mm	337	24-JAN-2011	24-JAN-2012	CS

※ The test equipments used are calibrated and can be traced to National ITRI and International Standards.

1.3 Auxiliary Equipments

1.3.1. Provided by HongAn Technology Co., Ltd. for emission test.

No.	Equipment	Model No.	Serial No.	EMC Approved	Brand	Description	
						Data Cable	Power Cable
01	TV Monitor	X19	7005820	BSMI	SONY	AV Cable Shilded(Foil), 1.5m	Unshielded, 1.8m

1.3.2. Provided by HongAn Technology Co., Ltd. for immunity test.

No.	Equipment	Model No.	Serial No.	EMC Approved	Brand	Description	
						Data Cable	Power Cable
01	TV Monitor	X19	7005820	BSMI	SONY	AV Cable Shilded(Foil), 1.5m	Unshielded, 1.8m

1.3.3. Provided by the Manufacturer

No.	Equipment	Model No.	Serial No.	EMC Approved	Brand	Description	
						Data Cable	Power Cable
N/A	N/A	N/A	N/A	N/A	N/A	N/A	N/A

1.4 EUT SETUP

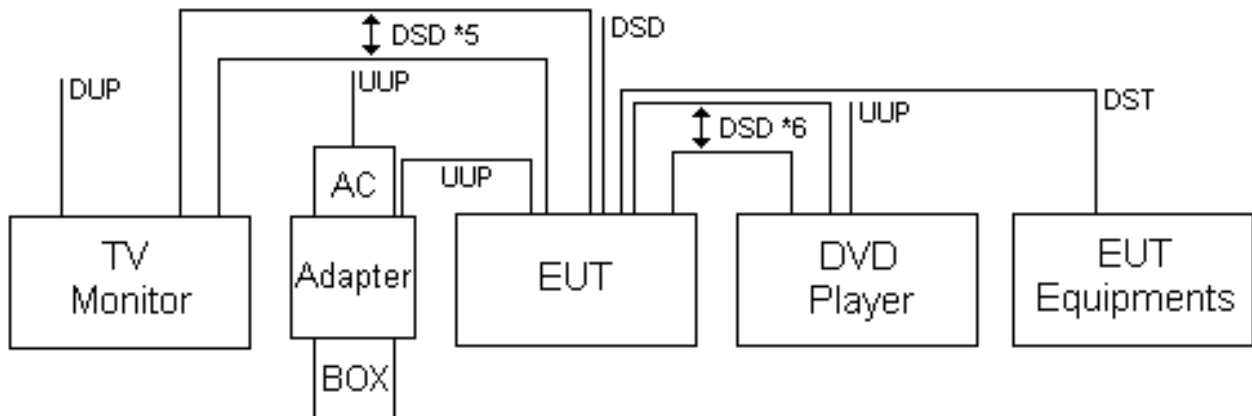

Note:

1. Main Test Sample: YEXXDALX
The series products were not tested.
2. I/O Port Setup

Type of Port	Total Q'ty	Test Status
AUDIO IN	3	Operating 3
AUDIO OUT	3	Operating 2
VIDEO IN	3	Operating 3
VIDEO OUT	3	Operating 3
Power	1	Operating 1
LAN OUT	1	Operating 1

3. Legend:

UUD : Undetachable Unshielded Data cable.	UUP : Undetachable Unshielded Power cord.
USD : Undetachable Shielded Data cable.	USP : Undetachable Shielded Power cord.
DSD : Detachable Shielded Data cable.	DUP : Detachable Unshielded Power cord.
DUD : Detachable Unshielded Data cable.	DSP : Detachable Shielded Power cord.
UTP : Unshielded Data Twisted Pair Cable.	STP : Shielded Data Twisted Pair Cable.

1.5 Identifying the Final Test Mode

1. Operation Mode 1: Play DVD Movie

Note: After pre-test, we identified that the Operation Mode 1(the worst case) was most likely to cause maximum disturbance and most likely to be susceptible to disturbance. Therefore, the Final EMC Assessment was performed for the worst case. All pre-test data show at appendix.

1.6 Final Test Mode

Operation Mode 1:Play DVD Movie

1.7 Condition of Power Supply

AC 230 V; 50 Hz

1.8 EUT Configuration

1. Setup the EUT as shown in Sec.1.4 EUT SETUP.
2. Turn on the power of all equipments.
3. Activate the selected Final Test Mode.

1.9 Qualification of Test Facility

BSMI Certificate No. : SL2-IS-E-0023, SL2-IN-E-0023, SL2-R1-E-0023, SL2-R2-E-0023, SL2-A1-E-0023, SL2-L1-E-0023.

Nemko Authorization No. : ELA 184

VCCI Certificate No. : R-2156, C-2329, T-219

TAF Accreditation No. : 1163

FCC Designation No. : TW1001

2 Conducted Disturbance Emission Test

2.1 Test Instruments

Refer to Sec. 1.2 Test Instruments.

2.2 Test Arrangement and Procedure

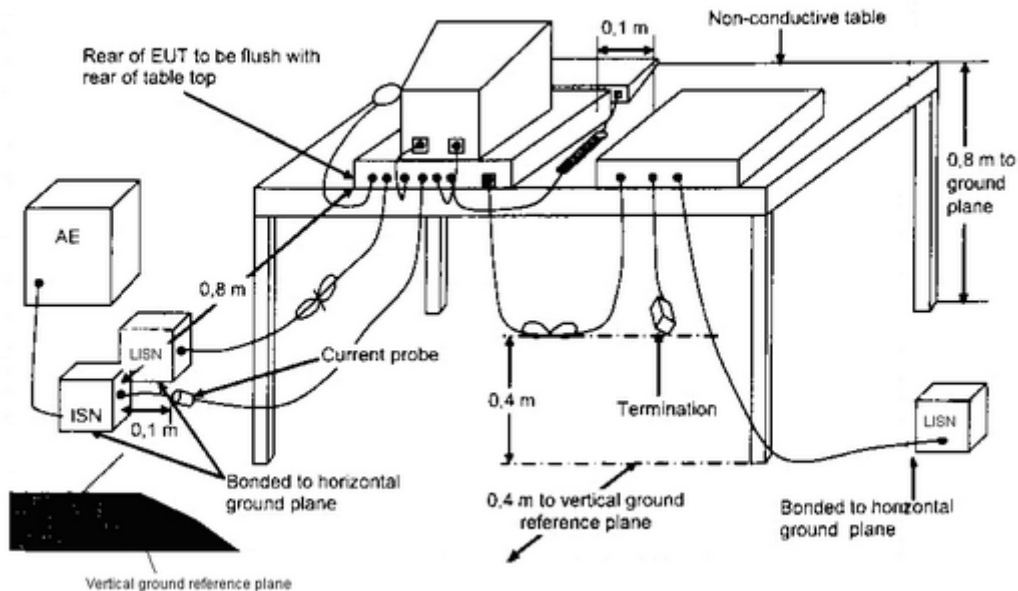

Table-top Equipment

- The EUT was placed on a non-conductive table which was 80 cm above the horizontal coupling plane. The rear of the EUT was 40 cm from the vertical coupling plane.
- The excess interface cables were folded at the cable center into a bundle no longer than 40 cm, so that the bundles were on the table.
- The EUT was connected to the main power through a L.I.S.N. This set up provided 50 ohm / 50 μ H coupling impedance for the measuring equipment.
- All auxiliary equipment received power from a second L.I.S.N.
- The conducted emissions were measured between the Line Phase and the PE ground and between the Neutral Phase and the PE ground using an EMI Receiver.
- The values were recorded.

2.3 Conducted Disturbance Limit

Limits for conducted disturbance at the mains ports of Class B ITE

Frequency Range MHz	Limit [dB (μV)]	
	Quasi-Peak	Average
0.15~0.50	66~56	56~46
0.50~5.0	56	46
5.0~30	60	50

Notes 1 At the transition frequencies the lower limit applies.
 Notes 2 The limit decreases linearly with the logarithm of the frequency in the range 0.15MHz to 0.50MHz.

Limits of conducted common mode (asymmetric mode) disturbance at telecommunication ports in the frequency range 0.15 MHz to 30 MHz for Class B equipment

Frequency Range MHz	Voltage Limits dB (μV)		Current Limits dB (μA)	
	Quasi-peak	Average	Quasi-peak	Average
0.15 ~ 0.5	84 ~ 74	74 ~ 64	40 ~ 30	30 ~ 20
0.5 ~ 30	74	64	30	20

NOTE 1 The limits decrease linearly with the logarithm of the frequency in the range 0.15 MHz to 0.5 MHz.
 NOTE 2 The current and voltage disturbance limits are derived for use with an impedance stabilization network (ISN) which presents a common mode (asymmetric mode) of 150 Ω to the telecommunication port under test (conversion factor is $20 \log_{10} 150 / 1 = 44$ dB).

2.4 Test Result

Compliance.

The final test data are shown on the following page(s).

Conducted Disturbance Emission Test Data for Mains Port

Test Date : 09-DEC-2011 Tested by : M.S.SHI
 Temp. : 22 °C Humidity : 51 %
 Power Mains : 230V/50Hz Power Line : LINE
 Description : N/A

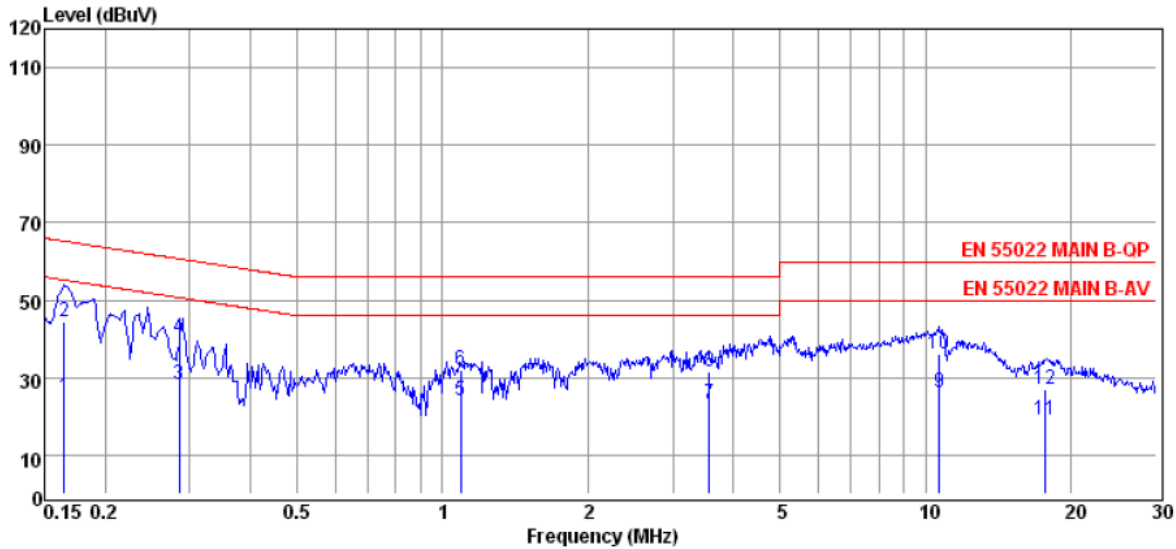

No.	Freq MHz	Reading dBµV	C.F dB	Result dBµV	Limit dBµV	Margin dB	Power Line	Remark
1	0.17	24.50	0.40	24.90	55.21	-30.31	LINE	Average
2	0.17	43.90	0.40	44.30	65.21	-20.91	LINE	QP
3	0.29	28.00	0.38	28.38	50.67	-22.29	LINE	Average
4	0.29	39.70	0.38	40.08	60.67	-20.59	LINE	QP
5	1.09	23.80	0.46	24.26	46.00	-21.74	LINE	Average
6	1.09	31.60	0.46	32.06	56.00	-23.94	LINE	QP
7	3.56	22.81	0.59	23.40	46.00	-22.60	LINE	Average
8	3.56	31.01	0.59	31.60	56.00	-24.40	LINE	QP
9	10.68	25.20	0.90	26.10	50.00	-23.90	LINE	Average
10	10.68	35.10	0.90	36.00	60.00	-24.00	LINE	QP
11	17.71	17.80	1.16	18.96	50.00	-31.04	LINE	Average
12	17.71	25.90	1.16	27.06	60.00	-32.94	LINE	QP

- Peak, Average and QP signifies the measurement detector used for performing measurements.
- Negative number in the margin column indicates the amount (in dB) that the recorded emission is below the limit.
- P denotes Phase, N denotes Neutral, AV denotes Average, QP denotes Quasi-Peak.
- Corr. Factor = Insertion loss(LISN Factor)+ Cable loss.
- Margin value = (Measured+ Corr. Factor) – limit value.

Conducted Disturbance Emission Test Data for Main Port

Test Date : 09-DEC-2011 Tested by : M.S.SHI
 Temp. : 22 °C Humidity : 51 %
 Power Mains : 230V/50Hz Power Line : Neutral
 Description : N/A

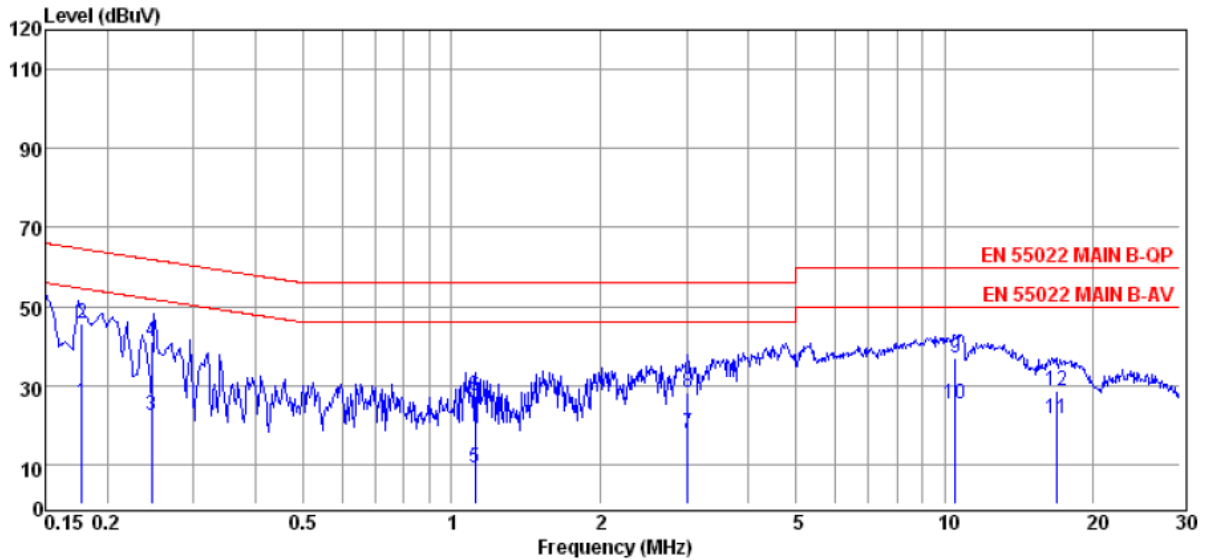

No.	Freq MHz	Reading dBμV	C.F dB	Result dBμV	Limit dBμV	Margin dB	Power Line	Remark
1	0.18	25.50	0.39	25.89	54.58	-28.69	NEUTRAL	Average
2	0.18	45.10	0.39	45.49	64.58	-19.09	NEUTRAL	QP
3	0.25	22.01	0.37	22.38	51.89	-29.51	NEUTRAL	Average
4	0.25	40.81	0.37	41.18	61.89	-20.71	NEUTRAL	QP
5	1.12	8.50	0.46	8.96	46.00	-37.04	NEUTRAL	Average
6	1.12	27.00	0.46	27.46	56.00	-28.54	NEUTRAL	QP
7	3.02	17.50	0.53	18.03	46.00	-27.97	NEUTRAL	Average
8	3.02	27.80	0.53	28.33	56.00	-27.67	NEUTRAL	QP
9	10.53	35.89	0.87	36.76	50.00	-13.24	NEUTRAL	Average
10	10.53	24.29	0.87	25.16	50.00	-24.84	NEUTRAL	Average
11	16.91	20.41	1.05	21.46	50.00	-28.54	NEUTRAL	Average
12	16.91	27.41	1.05	28.46	60.00	-31.54	NEUTRAL	QP

- Peak, Average and QP signifies the measurement detector used for performing measurements.
- Negative number in the margin column indicates the amount (in dB) that the recorded emission is below the limit.
- P denotes Phase, N denotes Neutral, AV denotes Average, QP denotes Quasi-Peak.
- Corr. Factor = Insertion loss(LISN Factor)+ Cable loss.
- Margin value = (Measured+ Corr. Factor) – limit value.

3 Radiated Disturbance Emission Test

3.1 Test Instruments

Refer to Sec. 1.2 Test Instruments.

3.2 Test Arrangement and Procedure

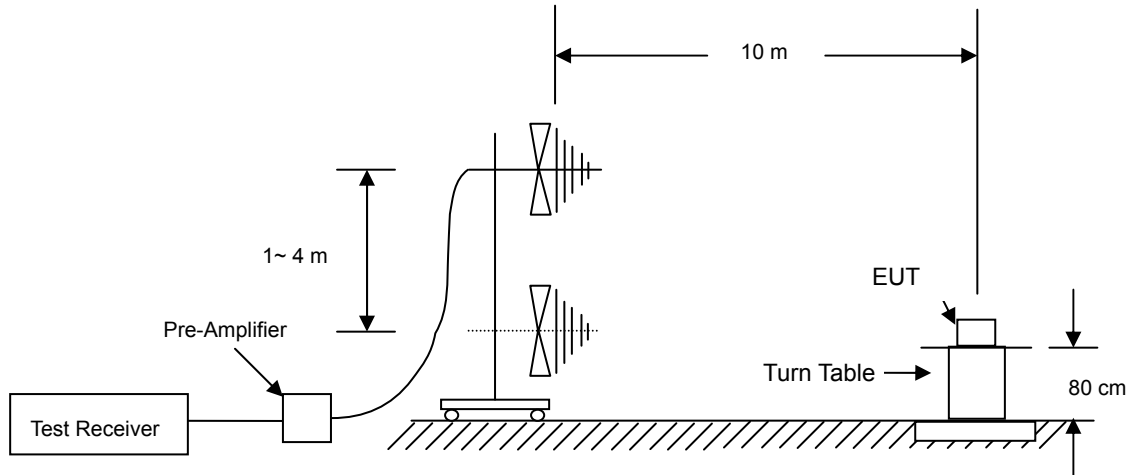

Table-top Equipment

- The EUT was placed on a non-conductive turntable which was 80 cm above the horizontal ground plane. The EUT was set 10 m away from the receiving antenna that was mounted on a non-conductive mast.
- Main cables draped to the ground plane and were routed to the mains power outlet. The mains power outlet was bonded to and did not protrude above the ground plane.
- The antenna was adjusted between 1 m and 4 m in height above the ground plane and the Antenna-to-EUT azimuth was also varied during the measurements to find the top 6 maximum meter readings within the frequency range limit as indicated in Sec 3.3.
- The radiated emissions were measured when the Antenna-to-EUT polarization was set horizontally and vertically.
- The values were recorded.

3.3 Radiated Disturbance Limit

Limits for radiated disturbance of Class B ITE		
Frequency Range (MHz)	Measuring Distance (Meter)	Quasi-peak Limits [dB (μV/m)]
30~230	10	30
230~1000	10	37

Note1 The lower limit shall apply at the transition frequencies.
 Note2 Additional provisions may be required for cases where interference occurs.

Limits for radiated disturbance of Class B ITE			
Frequency Range (GHz)	Measuring Distance (Meter)	Average Limits [dB (μV/m)]	Peak Limits [dB (μV/m)]
1 ~ 3	3	50	70
3 ~ 6	3	54	74

Note The lower limit shall apply at the transition frequencies.

3.4 Test Result

Compliance

The final test data are shown on the following page(s).

Radiated Disturbance Emission Test Data- Horizontal

Test Date : 09-DEC-2011 Tested by : M.S.SHI
 Temp. : 23 °C Humidity : 51 %
 Description : N/A

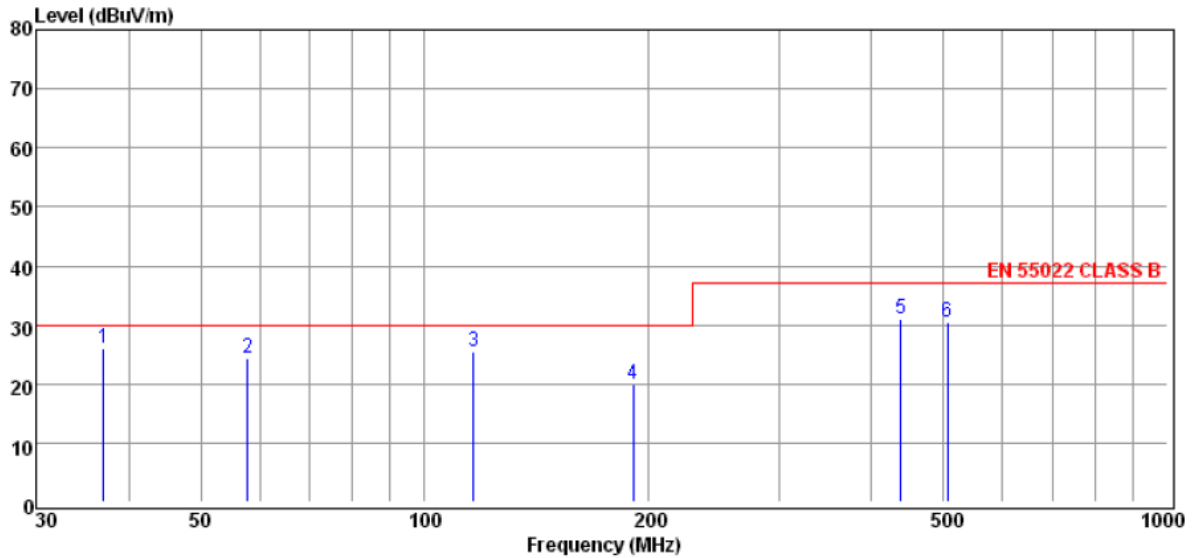

No.	Freq MHz	Reading dBuV	C.F dB	Result dBuV/m	Limit dBuV/m	Margin dB	Height cm	Angle deg	Antenna Pol.	Remark
1	36.96	40.95	-14.90	26.05	30.00	-3.95	400	40	HORIZONTAL	QP
2	57.78	46.87	-22.56	24.31	30.00	-5.69	400	55	HORIZONTAL	Peak
3	116.49	42.48	-17.02	25.46	30.00	-4.54	398	90	HORIZONTAL	QP
4	190.79	39.77	-19.78	19.99	30.00	-10.01	395	37	HORIZONTAL	Peak
5	438.20	42.66	-11.65	31.01	37.00	-5.99	381	114	HORIZONTAL	QP
6	506.60	41.11	-10.76	30.35	37.00	-6.65	280	182	HORIZONTAL	Peak

- Negative number in the margin column indicates the amount (in dB) that the recorded emission is Below the limit.
- V means in Vertical Antenna Polarization, H means in Horizontal, and QP means in Quasi-Peak.
- Corrected Factor = Insertion loss (Antenna Factor) + Cable loss.
- Corrected Reading = Reading + Corrected Factor.
- Margin limit = Correction Reading - limit value.

Radiated Disturbance Emission Test Data- Vertical

Test Date : 09-DEC-2011 Tested by : M.S.SHI
 Temp. : 23 °C Humidity : 51 %
 Description : N/A

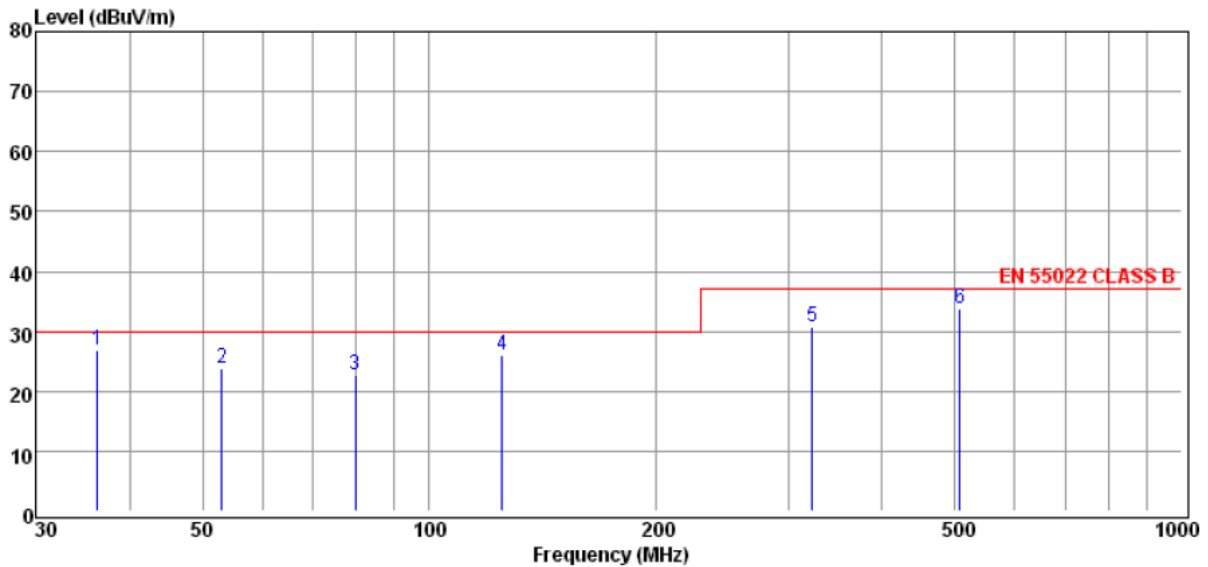

No.	Freq MHz	Reading dBμV	C.F dB	Result dBμV/m	Limit dBμV/m	Margin dB	Height cm	Angle deg	Antenna Pol.	Remark
1	36.21	41.29	-14.45	26.84	30.00	-3.16	100	56	VERTICAL	QP
2	53.08	45.31	-21.63	23.68	30.00	-6.32	100	17	VERTICAL	Peak
3	79.88	45.03	-22.27	22.76	30.00	-7.24	100	99	VERTICAL	Peak
4	125.14	43.10	-16.99	26.11	30.00	-3.89	102	36	VERTICAL	QP
5	322.80	45.50	-14.77	30.73	37.00	-6.27	110	80	VERTICAL	QP
6	507.00	44.40	-10.76	33.64	37.00	-3.36	205	150	VERTICAL	QP

- Negative number in the margin column indicates the amount (in dB) that the recorded emission is Below the limit.
- V means in Vertical Antenna Polarization, H means in Horizontal, and QP means in Quasi-Peak.
- Corrected Factor = Insertion loss (Antenna Factor) + Cable loss.
- Corrected Reading = Reading + Corrected Factor.
- Margin limit = Correction Reading - limit value.

4 Harmonic Current Emission Measurement

4.1 Test Instruments

Refer to Sec. 1.2 Test Instruments.

4.2 Test Configuration and Procedure

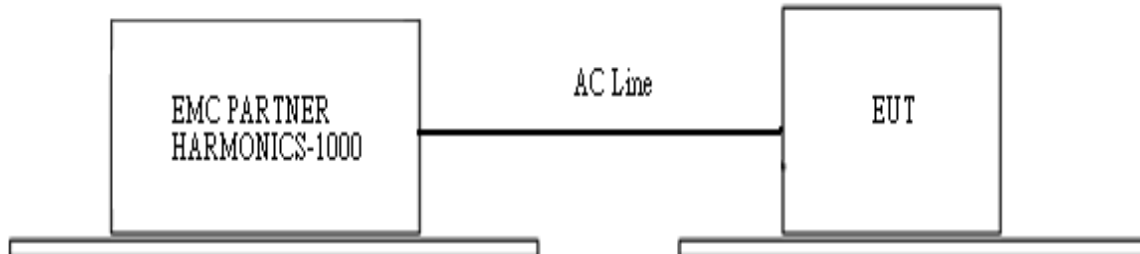

- The EUT was set in series with the Power Analyzer through an Impedance Network for the measurement of harmonic currents.
- The supply voltage and frequency setting on the Programmable AC Source was programmed as the rated voltage and frequency of the EUT.
- Classify the EUT class in accordance with the EN61000-3-2 for the purpose of harmonic current limitation. The measurement was automatically performed by test software. The test result was collected and analyzed by the computer.

4.3 EUT Operation Condition

Temperature	Humidity	Atmospheric Pressure	Tested by	Test Date
23°C	50%RH	1015 mbar	M.S.SHI	12-DEC-2011

4.4 Test Limit

Class A Equipment

Harmonic Order (n)	Maximum permissible harmonic current (A)
Odd harmonics	
3	2.30
5	1.14
7	0.77
9	0.40
11	0.33
13	0.21
$15 \leq n \leq 39$	$0.15 * 15 / n$
Even harmonics	
2	1.08
4	0.43
6	0.30
$8 \leq n \leq 40$	$0.23 * 8 / n$

4.5 Test Result

Compliance

The final test data are shown on the following page(s).

Harmonic Current Emission Measurement Test Data

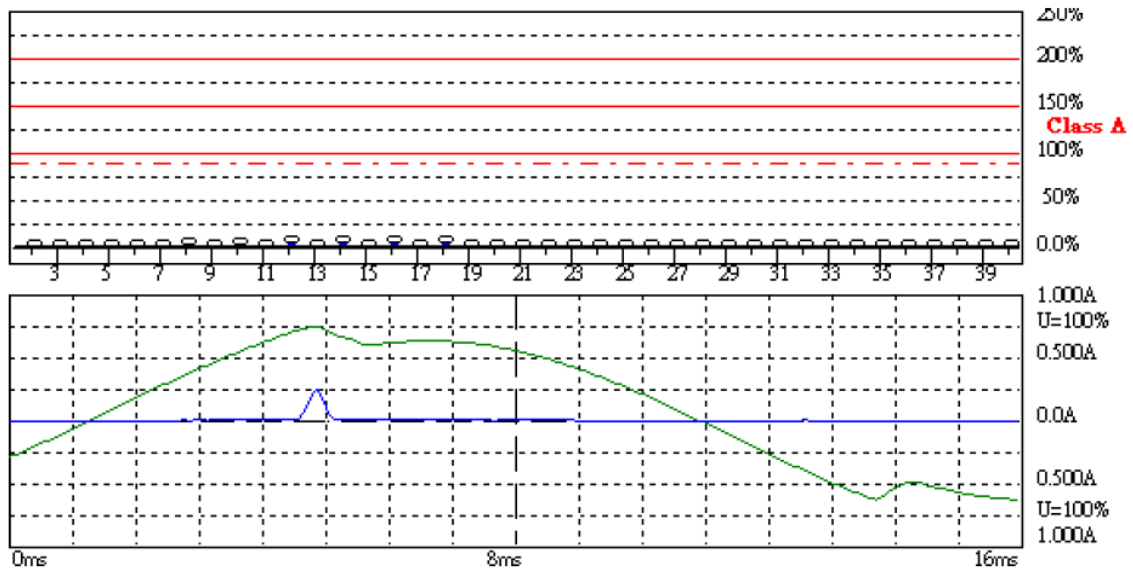

Urms = 203.8V Freq = 59.906 Range: 1 A
 Irms = 0.034A Ipk = 0.573A cf = 16.76
 P = 1.497W S = 6.966VA pf = 0.215
 THDi = 95.0 % THDu = 13.8 % Class A

Test - Time : 10min (100 %)

Test completed, Result: PASSED

Order	Freq. [Hz]	Iavg [A]	Irms [A]	Imax [A]	Limit [A]	Status
1	60	0.0101	0.0103	0.0106		
2	120	0.0020	0.0048	0.0056	1.0800	
3	180	0.0093	0.0093	0.0096	2.3000	
4	240	0.0051	0.0052	0.0058	0.4300	
5	300	0.0087	0.0089	0.0092	1.1400	
6	360	0.0058	0.0057	0.0064	0.3000	
7	420	0.0080	0.0082	0.0085	0.7700	
8	480	0.0062	0.0060	0.0070	0.2300	
9	540	0.0071	0.0074	0.0078	0.4000	
10	600	0.0064	0.0063	0.0072	0.1840	
11	660	0.0063	0.0065	0.0070	0.3300	
12	720	0.0065	0.0064	0.0072	0.1533	
13	780	0.0048	0.0058	0.0062	0.2100	
14	840	0.0063	0.0063	0.0069	0.1314	
15	900	0.0033	0.0052	0.0057	0.1500	
16	960	0.0059	0.0060	0.0063	0.1150	
17	1020	0.0007	0.0049	0.0053	0.1324	
18	1080	0.0049	0.0055	0.0057	0.1022	
19	1140	0.0000	0.0047	0.0050	0.1184	
20	1200	0.0004	0.0049	0.0052	0.0920	
21	1260	0.0000	0.0045	0.0047	0.1071	
22	1320	0.0000	0.0044	0.0047	0.0836	
23	1380	0.0000	0.0041	0.0043	0.0978	
24	1440	0.0000	0.0039	0.0043	0.0767	
25	1500	0.0000	0.0037	0.0040	0.0900	
26	1560	0.0000	0.0035	0.0039	0.0708	
27	1620	0.0000	0.0034	0.0036	0.0833	
28	1680	0.0000	0.0032	0.0035	0.0657	
29	1740	0.0000	0.0031	0.0032	0.0776	
30	1800	0.0000	0.0029	0.0032	0.0613	
31	1860	0.0000	0.0028	0.0030	0.0726	
32	1920	0.0000	0.0027	0.0029	0.0575	
33	1980	0.0000	0.0025	0.0027	0.0682	
34	2040	0.0000	0.0024	0.0026	0.0541	
35	2100	0.0000	0.0023	0.0025	0.0643	
36	2160	0.0000	0.0022	0.0024	0.0511	
37	2220	0.0000	0.0021	0.0023	0.0608	
38	2280	0.0000	0.0020	0.0022	0.0484	
39	2340	0.0000	0.0019	0.0021	0.0577	
40	2400	0.0000	0.0019	0.0020	0.0460	

5 Voltage Fluctuations and Flicker Measurement

5.1 Test Instruments

Refer to Sec. 1.2 Test Instruments.

5.2 Test Configuration and Procedure

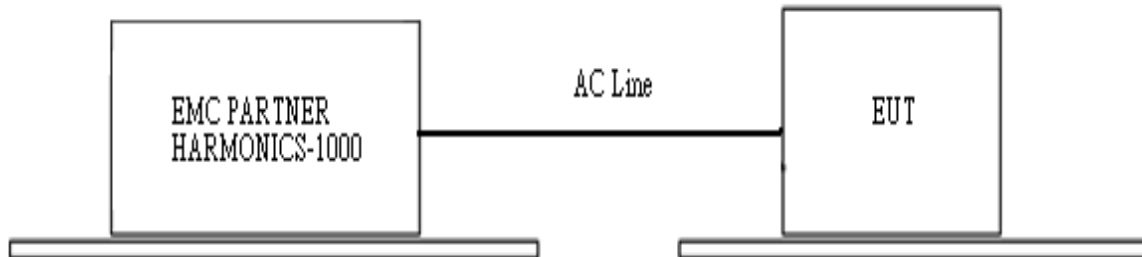

- The EUT was set in series with the Power Analyzer through an Impedance Network for the measurement of Flicker Voltage.
- The supply voltage and frequency setting on the Programmable AC Source was programmed as the rated voltage and frequency of the EUT.
- The measurement was automatically performed by test software. The test result was collected and analyzed by the computer.

5.3 EUT Operation Condition

Temperature	Humidity	Atmospheric Pressure	Tested by	Test Date
23°C	50%RH	1015 mbar	M.S.SHI	12-DEC-2011

5.4 Test Limit

Test Item	Limit	Test Item	Limit
Plt	: 0.65	Pst	: 1.00
dmax	: 4.00 %	dc	: 3.30 %
dtLim	: 3.30 %	dt>Lim	: 500ms

5.5 Test Result

Compliance

The final test data are shown on the following page(s).

Voltage Fluctuations and Flicker Measurement Test Data

Flickermeter 1000-4-15 for 120V/60Hz

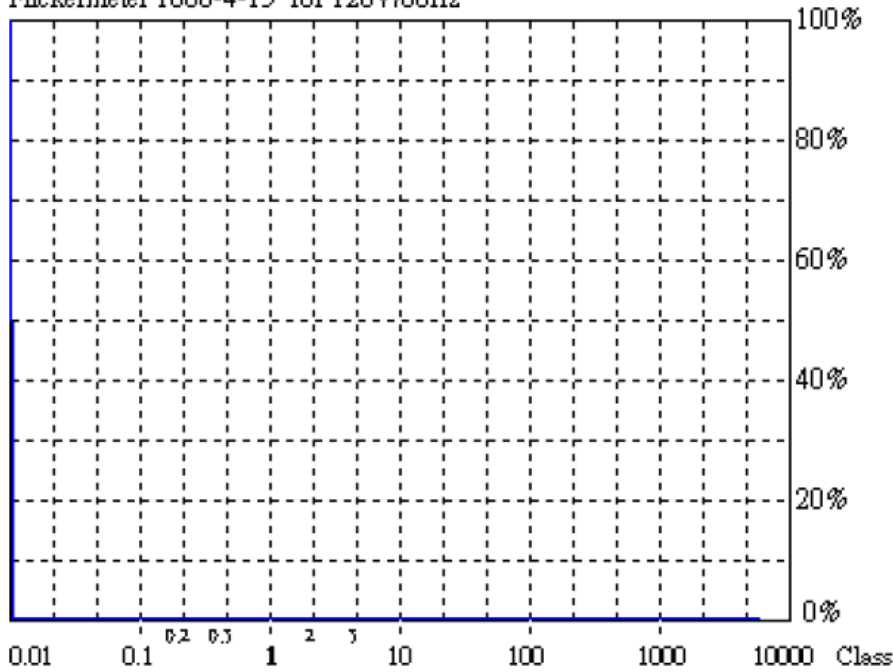

Actual Flicker (Fli): 0.00
Short-term Flicker (Pst): 0.07
 Limit (Pst): 1.00
Long-term Flicker (Plt): 0.07
 Limit (Plt): 0.65
Maximum Relative Volt. Change (dmax): 0.05%
 Limit (dmax): 4.00%
Relative Steady-state Voltage Change (dc): 0.07%
 Limit (dc): 3.30%
Maximum Interval exceeding 3.30% (dt): 0.00ms
 Limit (dt>Lim): 500ms

Urms = 204.0V Freq = 59.757 Range: 2 A
 Irms = 0.065A Ipik = 1.084A cf = 16.57
 P = 3.043W S = 13.35VA pf = 0.228

Test - Time : 1 x 10min = 10min (100 %)

LIN (Line Impedance Network) : L: 0.24ohm +j0.15ohm N: 0.16ohm +j0.10ohm

Limits : Plt : 0.65 Pst : 1.00
 dmax : 4.00 % dc : 3.30 %
 dtLim: 3.30 % dt>Lim: 500ms

Test completed, Result: PASSED

Plt = 0.072

	Pst	dmax	dc	dt>Lim
		[%]	[%]	[ms]
1	0.072	0.050	0.070	0.000

6 Electrostatic Discharge Immunity Test

6.1 Test Instruments

Refer to Sec. 1.2 Test Instruments.

6.2 Test Configuration and Procedure

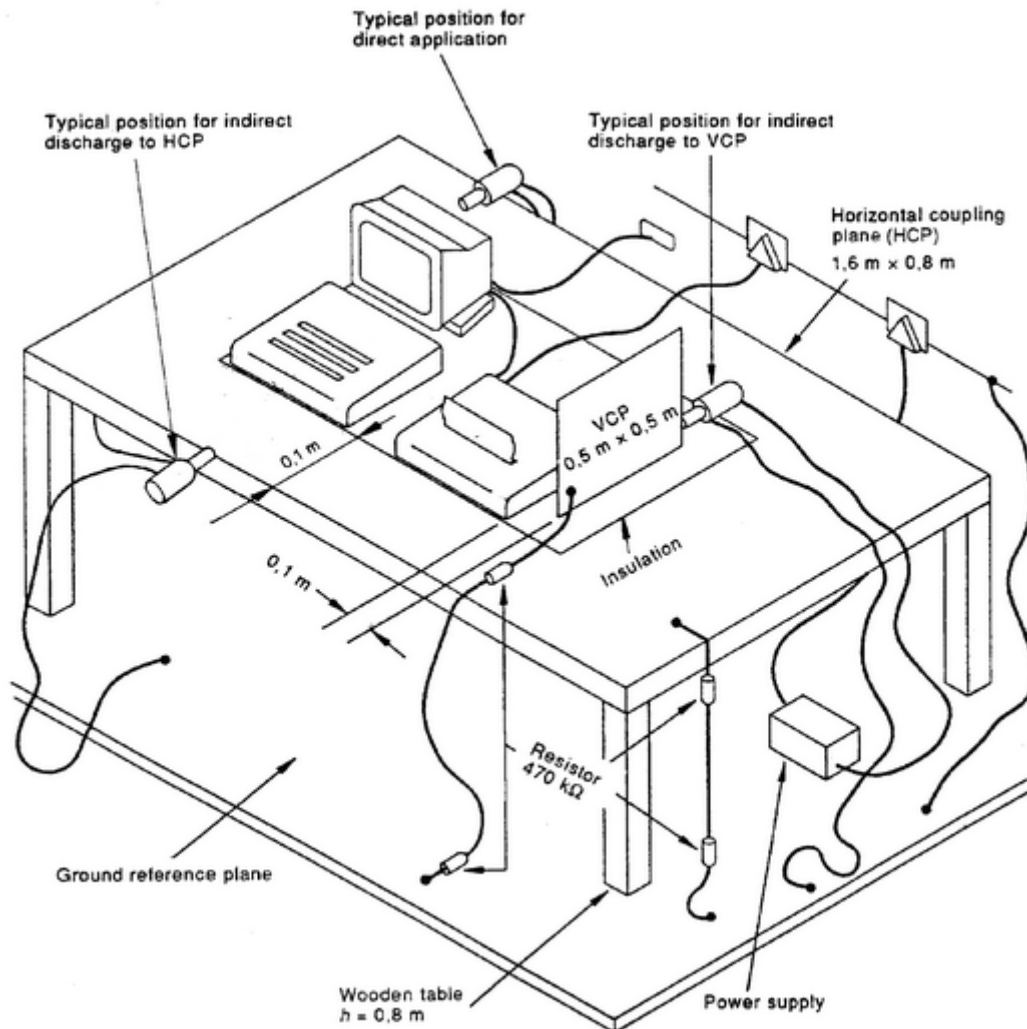

Table-top Equipment

- The EUT was located on a 0.8 m high wooden table standing on the ground reference plane with a 1.6 * 0.8 m horizontal coupling plane on the top. The EUT and cables was isolated from the coupling plane by an insulating support 0.5 mm thick.
- In Contact Discharge, the EUT was exposed to minimum 200 discharges, 10 each at negative and positive polarity on the selected test points (the selected test points were marked with red labels on the EUT)
- In Air Discharge, the EUT exposed to minimum of 10 single discharges on the selected test points.
- The result was observed and analyzed.

6.3 Test Result

Test Date	: 13 - DEC - 2011	Tested By	: M.S. SHI
Temp.	: 22 °C	Pressure In Bar	: 1014 mB
Humidity	: 52 %	Test Condition Mains	: 230VAC/50Hz
Description	: N/A		

Basic Standard : EN 61000-4-2

Level.

Customer Apply to	Contact Discharge		Customer Apply to	Air Discharge	
	Level	Test Voltage (KV)		Level	Test Voltage (KV)
<input type="checkbox"/>	1	± 2	<input type="checkbox"/>	1	± 2
<input checked="" type="checkbox"/>	2	± 4	<input type="checkbox"/>	2	± 4
<input type="checkbox"/>	3	± 6	<input checked="" type="checkbox"/>	3	± 8
<input type="checkbox"/>	4	± 8	<input type="checkbox"/>	4	± 15

Test Data.

By Product Standard : EN 55024, Performance Criteria : A B C D

Direct Discharge.

Test Point on EUT	Polarity	Test Voltage (KV)		Performance Criteria (observed)		Result	
		Contact	Air	Contact	Air	Contact	Air
Surface of case	+	2, 4	2, 4, 8	B	B	P	P
	-	2, 4	2, 4, 8	B	B	P	P
Junction of case	+	2, 4	2, 4, 8	B	B	P	P
	-	2, 4	2, 4, 8	B	B	P	P
ALL I/O Port & Bracket	+	2, 4	2, 4, 8	B	B	P	P
	-	2, 4	2, 4, 8	B	B	P	P

Indirect Discharge.

Test Point on EUT	Polarity	Test Voltage (KV)		Performance Criteria (observed)		Result	
		VCP	HCP	VCP	HCP	VCP	HCP
Front	+	2, 4	2, 4	B	B	P	P
	-	2, 4	2, 4	B	B	P	P
Rear	+	2, 4	2, 4	B	B	P	P
	-	2, 4	2, 4	B	B	P	P
Left	+	2, 4	2, 4	B	B	P	P
	-	2, 4	2, 4	B	B	P	P
Right	+	2, 4	2, 4	B	B	P	P
	-	2, 4	2, 4	B	B	P	P
Bottom	+	2, 4	2, 4	B	B	P	P
	-	2, 4	2, 4	B	B	P	P

Performance Criteria (observed) : [A] means " No loss of function " [B] means " Self-restoring "

: [C] means " Reset by operator " [D] means " Damage "

Result : [P] means " Pass " [F] means " Fail "

: [N/A] means "Not Tested"

Test Result : **Compliance** **Noncompliance**

7 Radio-frequency, Electromagnetic Field Immunity Test

7.1 Test Instruments

Refer to Sec. 1.2 Test Instruments.

7.2 Test Configuration and Procedure

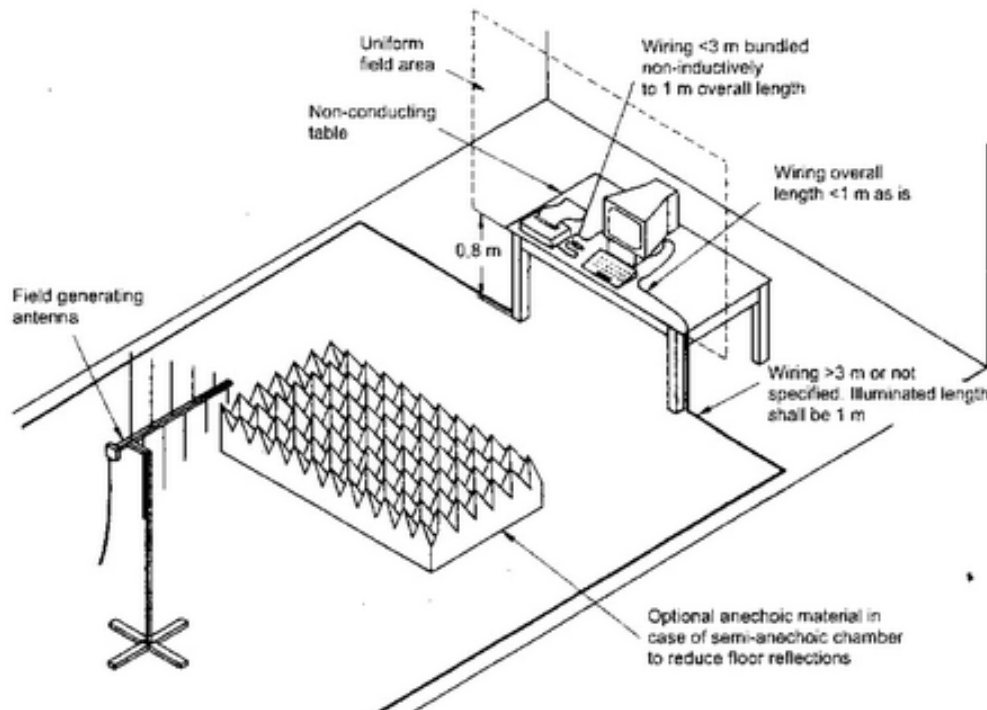

Table-top Equipment

- The field calibration was executed to create a uniform field area (UFA), 3 m away from the antenna, to ensure the validity of the test results.
- The EUT was placed on a non-conductive table 0.8 m high in the UFA.
- The EUT was then connected to power and signal wires according to relevant installation instruction.
- The EUT was positioned so that the four sides of the EUT were exposed to the electromagnetic field in sequence. In each position, the performance of the EUT was investigated and monitored by a CCD camera.

7.3 Test Result

Test Date	: 13 - DEC - 2011	Tested By	: M.S. SHI
Temp.	: 22 °C	Pressure In Bar	: 1014 mB
Humidity	: 52 %	Test Condition Mains	: 230VAC/50Hz
Description	: N/A		

Basic Standard : EN 61000-4-3

Level.

Customer Apply to	Level	Test field strength (V/m)
<input type="checkbox"/>	1	1
<input checked="" type="checkbox"/>	2	3
<input type="checkbox"/>	3	10

Test Data.

By Product Standard : EN 55024, Performance Criteria : A B C D
 Modulation : 1KHz, AM 80% sinusoidal.

Frequency Range (MHz)	Table Position (°)	Field (V/m)	Performance Criteria (observed).		Result	
			Antenna Polarization		Horizontal.	Vertical.
			Horizontal.	Vertical.		
80 to 1000	0	3	A	A	P	P
80 to 1000	90	3	A	A	P	P
80 to 1000	180	3	A	A	P	P
80 to 1000	270	3	A	A	P	P

Performance Criteria (observed) : [A] means " No loss of function " [B] means " Self-restoring "
 : [C] means " Reset by operator " [D] means " Damage "
 Result : [P] means " Pass " [F] means " Fail "
 : [N/A] means "Not Tested"

Test Result : **Compliance** **Noncompliance**

8 Electrical Fast Transient Test

8.1 Test Instrument

Refer to Sec. 1.2 Test Instruments.

8.2 Test Configuration and Procedure

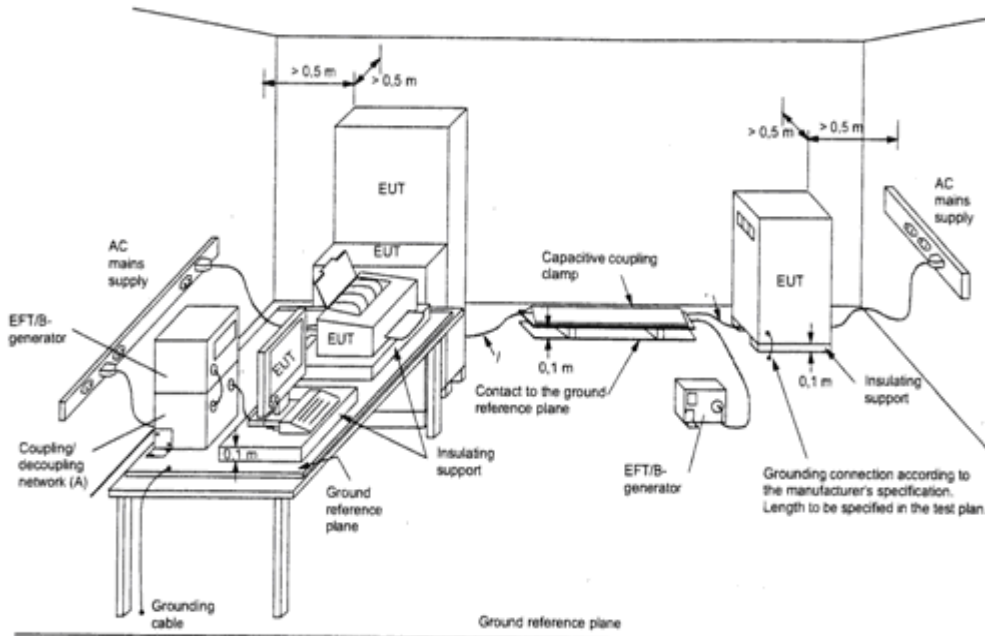

Table-top Equipment

- The EUT was placed on a table of 0.4 m height above the 1 * 1.5 m metallic ground reference plane, which projected beyond the EUT by at least 0.1 m on all sides.
- The ground plane was connected to the protective earth.
- The distance between the EUT and all other conductive structures, except the ground plane beneath the EUT was more than 0.5 m.
- The length of the signal and power lines between the coupling device and the EUT was 0.5 m.
- All cables to the EUT were placed on the insulation support 0.1 m above the ground reference plane.
- The EUT was connected to the power mains through a coupling device that directly coupled the EFT interference signal. Each of the Line, Neutral and Protective Earth conductors was injected with burst for 60 sec. The test time was broken down into six 10 sec bursts separated by a 10 sec pause for avoiding synchronization. Both voltage polarities were applied for each test level.
- Operating condition was shown on the monitor and observed.

8.3 Test Result

Test Date	: 13 - DEC - 2011	Tested By	: M.S. SHI
Temp.	: 22 °C	Pressure In Bar	: 1014 mB
Humidity	: 52 %	Test Condition Mains	: 230VAC/50Hz
Description	: N/A		

Basic Standard : EN 61000-4-4

Level

Open circuit output test voltage and repetition rate of the impulses							
Customer Apply to	Level	On Power Port, PE		Customer Apply to	Level	On I/O (input/output) Signal, Data and Control Ports	
		Voltage Peak (KV)	Repetition Rate (KHz)			Voltage Peak (KV)	Repetition Rate (KHz)
<input type="checkbox"/>	1	0.5	5	<input type="checkbox"/>	1	0.25	5
<input checked="" type="checkbox"/>	2	1.0	5	<input type="checkbox"/>	2	0.5	5
<input type="checkbox"/>	3	2.0	5	<input type="checkbox"/>	3	1.0	5
<input type="checkbox"/>	4	4.0	5	<input type="checkbox"/>	4	2.0	5

Test Data

By Product Standard : EN 55024, Performance Criteria : A B C D

On Power Port, PE

Inject Line	Voltage Peak (KV)	Polarity	Inject Method	Duration (Sec)	Performance Criteria(observed)	Result
L1	1	+	Direct	60	B	P
		-			B	P
L2	1	+	Direct	60	B	P
		-			B	P
PE	1	+	Direct	60	N/A	N/A
		-			N/A	N/A

On I/O (input/output) Signal, Data and Control Ports :

Test Port	Voltage Peak (KV)	Polarity	Inject Method	Duration (Sec)	Performance Criteria(observed)	Result
Signal	0.5	+	Indirect	60	N/A	N/A
		-			N/A	N/A

Performance Criteria (observed) : [A] means " No loss of function " [B] means " Self-restoring "

Result : [C] means " Reset by operator " [D] means " Damage "

: [P] means " Pass " [F] means " Fail "

: [N/A] means "Not Tested"

Test Result : Compliance Noncompliance

9 Surge Immunity Test

9.1 Test Instrument

Refer to Sec. 1.2 Test Instruments.

9.2 Test Configuration and Procedure

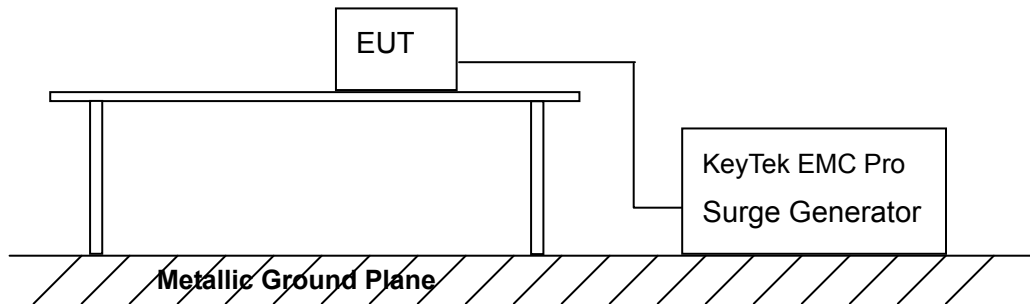

- The EUT was placed on a table of 0.4 m height above the 1 * 1.5 m metallic ground reference plane, which projected beyond the EUT by at least 0.1 m on all sides.
- The ground plane was connected to the protective earth.
- The length of power cord between the coupling device and the EUT is less than 2 m (provided by the manufacturer).
- The EUT was connected to the power mains through a coupling device that directly couples the Surge interference signal. The surge noise was applied synchronized to the voltage phase at the zero crossing and the peak value of the AC voltage wave (positive and negative).
- The surges were applied line to line and line(s) to earth. When testing line to earth the test voltage was applied successively between each of the lines and earth. Steps up to the test level specified increased the test voltage. All lower levels including the selected test level were tested. The polarity of each surge level included positive and negative test pulses.
- Operating condition was shown on the monitor and observed.

9.3 Test Result

Test Date	: 13 - DEC - 2011	Tested By	: M.S. SHI
Temp.	: 22 °C	Pressure In Bar	: 1014 mB
Humidity	: 52 %	Test Condition Mains	: 230VAC/50Hz
Description	: N/A		

Basic Standard : EN 61000-4-5

Level

Customer Apply to	Mode	Level	Open-circuit test voltage±10%(KV)	Customer Apply to	Mode	Level	Open-circuit test voltage±10%(KV)
<input type="checkbox"/>	Differential	1	0.5	<input type="checkbox"/>	Common	1	0.5
<input checked="" type="checkbox"/>	Differential	2	1.0	<input type="checkbox"/>	Common	2	1.0
<input type="checkbox"/>	Differential	3	2.0	<input type="checkbox"/>	Common	3	2.0
<input type="checkbox"/>	Differential	4	4.0	<input type="checkbox"/>	Common	4	4.0

Test Data

By Product Standard : EN 55024, Performance Criteria : A B C D

Differential Mode

Mode	Open-circuit test voltage (KV)	Delay (Sec)	Test	Polarity \ Angle	0°	90°	180°	270°	Result
					Performance Criteria (observed).				
L1 to L2	0.5, 1	60	5	+	B	B	B	B	P
				-	B	B	B	B	P

Common Mode

Mode	Open-circuit test voltage (KV)	Delay (Sec)	Test	Polarity \ Angle	0°	90°	180°	270°	Result
					Performance Criteria (observed).				
L1 to PE	0.5, 1, 2	60	5	+	N/A	N/A	N/A	N/A	N/A
				-	N/A	N/A	N/A	N/A	N/A
L2 to PE	0.5, 1, 2	60	5	+	N/A	N/A	N/A	N/A	N/A
				-	N/A	N/A	N/A	N/A	N/A

Performance Criteria (observed) : [A] means " No loss of function " [B] means " Self-restoring "

: [C] means " Reset by operator " [D] means " Damage "

Result : [P] means " Pass " [F] means " Fail "

: [N/A] means "Not Tested"

Test Result : Compliance Noncompliance

10 Radio-frequency, Conducted Disturbances Immunity Test

10.1 Test Instruments

Refer to Sec. 1.2 Test Instruments.

10.2 Test Configuration and Procedure

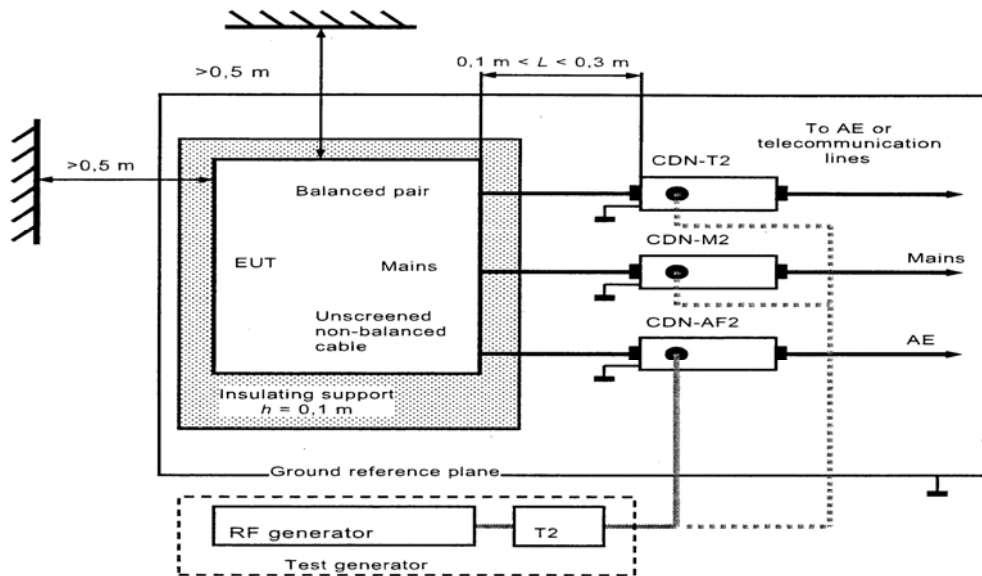

- The EUT was placed on an insulating support of 0.1 m height above a ground reference plane. All cables exiting the EUT was supported at a height of 30 mm above the ground reference plane.
- The EUT was connected to the power mains through a Coupling and Decoupling Networks (CDN).
- The CDN was located 0.3 m from the EUT as indicated in the diagram above.
- The test was performed with the test generator connected to each of the CDN in turn while the other non-excited RF input ports of the coupling devices were terminated by a 50 Ω terminator.
- The conducted disturbance was applied on the EUT from 150 kHz to 80 MHz using the signal levels established during the setting process. .
- Operating condition was shown on the monitor and observed.

10.3 Test Result

Test Date	: 13 - DEC - 2011	Tested By	: M.S. SHI
Temp.	: 22 °C	Pressure In Bar	: 1014 mB
Humidity	: 52 %	Test Condition Mains	: 230VAC/50Hz
Description	: N/A		

Basic Standard : EN 61000-4-6

Level

Customer Apply to	Level	Voltage Level (e.m.f.)	
		U ₀ [dB(μV)]	U ₀ [V]
<input type="checkbox"/>	1	120	1
<input checked="" type="checkbox"/>	2	130	3
<input type="checkbox"/>	3	140	10

Test Data.

By Product Standard : EN 55024, Performance Criteria : A B C D
 Modulation : 1KHz, AM 80% sinusoidal.

Input a.c. power ports

Frequency Range (MHz)	Voltage Level (e.m.f.)		Performance Criteria (observed)	Result
	U ₀ [dB(μV)]	U ₀ [V]		
0.15 to 80	130	3	A	P

Signal & Telecommunication ports :

Frequency Range (MHz)	Voltage Level (e.m.f.)		Performance Criteria (observed)	Result
	U ₀ [dB(μV)]	U ₀ [V]		
0.15 to 80	130	3	N/A	N/A

Performance Criteria (observed) : [A] means “ No loss of function ” [B] means “ Self-restoring ”
 : [C] means “ Reset by operator ” [D] means “ Damage ”
 Result : [P] means “ Pass ” [F] means “ Fail ”
 : [N/A] means “Not Tested”

Test Result : Compliance Noncompliance

11 Power Frequency Magnetic Field Immunity Test

11.1 Test Instruments

Refer to Sec. 1.2 Test Instruments.

11.2 Test Configuration and Procedure

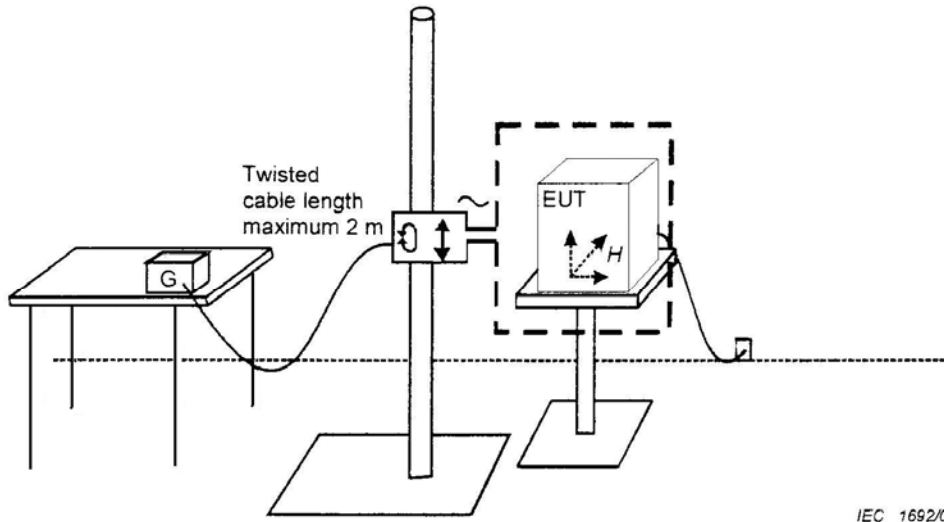

Table-top Equipment

- The EUT was placed on a non-magnetic metal ground plane of 0.25 mm thickness with the interposition of a 0.1 m thickness insulating support. The ground plane was connected to the protected earth.
- The EUT was placed at the center of the 1 * 1 m induction coil with the test generator placed within 3 m distance.
- The test was operated by moving and shifting the induction coil to expose to the test field.
- The operation condition was observed and analyzed.
- The induction coil was then rotated by 90° to expose the EUT to the test field with different orientations and the same procedure.

11.3 Test Result

Test Date	: 13 - DEC - 2011	Tested By	: M.S. SHI
Temp.	: 22 °C	Pressure In Bar	: 1014 mB
Humidity	: 52 %	Test Condition Mains	: 230VAC/50Hz
Description	: N/A		

Basic Standard : EN 61000-4-8

Level

Customer Apply to	Level	Magnetic field strength (A/m)
<input checked="" type="checkbox"/>	1	1
<input type="checkbox"/>	2	3
<input type="checkbox"/>	3	10
<input type="checkbox"/>	4	30
<input type="checkbox"/>	5	100

Test Data.

By Product Standard : EN 55024, Performance Criteria : A B C D

Power Frequency (Hz)	Magnetic field strength (A/m)	Duration (sec)	Orthogonal (axis)	Performance Criteria (observed)	Result
50	1	60	X	A	P
50	1	60	Y	A	P
50	1	60	Z	A	P

Performance Criteria (observed) : [A] means " No loss of function " [B] means " Self-restoring "

: [C] means " Reset by operator " [D] means " Damage "

Result : [P] means " Pass " [F] means " Fail "

: [N/A] means "Not Tested"

Test Result : Compliance Noncompliance

12 Voltage Dips, Short Interruptions Immunity Test

12.1 Test Instrument

Refer to Sec. 1.2 Test Instruments.

12.2 Test Configuration and Procedure

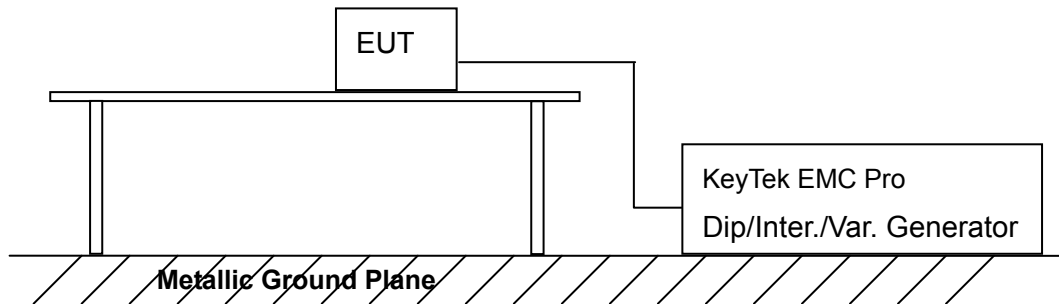

- The EUT was tested with (I) >95% voltage dip of supplied voltage with a duration of 0.5 periods (II) 30% voltage dip of supplied voltage with duration of 25 periods (III) >95% voltage interruption of supplied voltage with duration of 250 periods.
- For each selected combination of test level and duration with a sequence of dips / interruptions with intervals of 60 sec.
- The EUT was placed on a table of 0.4 m height above the 1 * 1.5 m metallic ground reference plane, which projected beyond the EUT by at least 0.1 m on all sides.
- The ground plane was connected to the protective earth.
- The performance of the EUT was monitored and recorded.

12.3 Test Result

Test Date	: 13 - DEC - 2011	Tested By	: M.S. SHI
Temp.	: 22 °C	Pressure In Bar	: 1014 mB
Humidity	: 52 %	Test Condition Mains	: 230VAC/50Hz
Description	: N/A		

Basic Standard : EN 61000-4-11

Level

Class	Test level and durations for voltage dips (t _s) (50 Hz/60 Hz)				
1	Case-by-case according to the equipment requirements				
2	0% during 1/2 cycle	0% during 1 cycle	70% during 25/30* cycles		
3	0% during 1/2 cycle	0% during 1 cycle	40% during 10/12* cycle	70% during 25/30* cycle	80% during 250/300* cycle
Class	Test level and durations for voltage dips (t _s) (50 Hz/60 Hz)				
1	Case-by-case according to the equipment requirements				
2	0 % during 250/300* cycles				
3	0 % during 250/300* cycles				
* "25/30 cycles" means "25 cycles for 50Hz test" and "30 cycles for 60 Hz test"					

Test Data.

Environmental Phenomenon : **Voltage Dips**

By Product Standard : EN 55024, Performance Criteria : >95% B ; 30% C

Voltage reduction (%)	Starting Phase Angle (°)	Periods	Performance Criterion (observed)	Result
> 95	0, 45, 90, 135, 180,225, 270, 315	0.5	B	P
30	0, 45, 90, 135, 180,225, 270, 315	25	C	P

Environmental Phenomenon : **Voltage interruptions**

By Product Standard : EN 55024, Performance Criteria : >95% C

Voltage reduction (%)	Starting Phase Angle (°)	Periods	Performance Criterion (observed)	Result
> 95	0, 45, 90, 135, 180,225, 270, 315	250	C	P

Performance Criteria (observed) : [A] means " No loss of function " [B] means " Self-restoring "

: [C] means " Reset by operator " [D] means " Damage "

Result : [P] means " Pass " [F] means " Fail "

: [N/A] means "Not Tested"

Test Result : **Compliance** **Noncompliance**

13 Photographs of the Tests

13.1 Conducted Disturbance Emission Test



Front View



Rear View

13.2 Radiated Disturbances Emission Test



Front View



Rear View

13.3 Harmonic Current Emission Test & Voltage Fluctuation and Flicker Emission Test



13.4 Electrostatic Discharge Immunity Test



13.5 Radio-frequency, Radio-frequency, Electromagnetic Field Immunity Test



13.6 Electrical Fast Transient / Burst Immunity Test



13.7 Surge Immunity Test



13.8 Conducted Disturbances Test, Induced by Radio-frequency Field Immunity Test



14 Photographs of the EUT



Front View of the EUT



Rear View of the EUT



Inside View of the EUT



Front View of the PCB

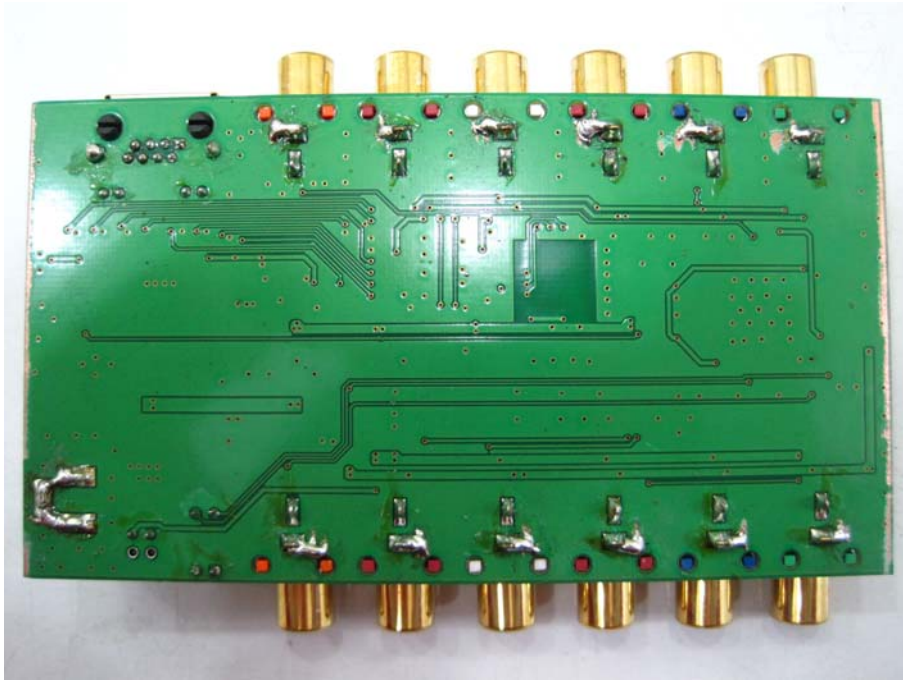

Rear View of the PCB



View of the EUT Equipments



View of the Power Adapter



View of the Power Adapter Cable Label



View of the AV Cable



View of the RJ45 Cable