

ADDRESS: No. 67-9, Shir Men Road, Tu Cheng City,
Taipei Hsien, Taiwan

PHONE : 886-2-22608375 FAX : 886-2-22748013

E - mail : hometek@ms15.hinet.net

CE TEST REPORT FOR

APPLICANT : Smart Home Engineering Corp.
ADDRESS : 10F., No. 493, Chung-Cheng Rd.,
Hsin-Tien City, Taipei 231, Taiwan, R. O. C.
Receipt Date : 11/08/2007 Final Test Date: 12/11/2007
EUT : Multimedia AV Switcher
MODEL NO. : YS0XXX

MEASUREMENT PROCEDURE USED

EN55022 CLASS B / EN61000-3-2 / EN61000-3-3 / EN55024 GIVEN IN
EUROPEAN COUNCIL DIRECTIVE 2004/108/EC

This test result of this report applies to above tested sample only.

This test report shall not be reproducing in part without written approval of HomeTek Technology Inc.

PREPARED BY :

HomeTek Technology Inc.

No. 67-9, Shir Men Road, Tu Cheng City,

Taipei Hsien. Taiwan

Report # : EB6K010

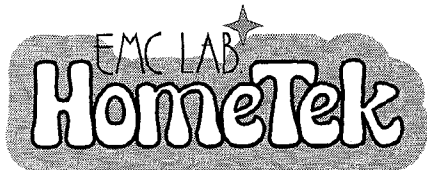

HomeTek Technology Inc.

ADDRESS: No. 67-9, Shir Men Road, Tu Cheng City,
Taipei Hsien

PHONE : 886-2-22608375 FAX : 886-2-22748013

E - mail : hometek@ms15.hinet.net

CERTIFICATE OF COMPLIANCE

EUT : Multimedia AV Switcher

MODEL NO. : YS0XXX

Receipt Date : 11/08/2007 Final Test Date: 12/15/2007

REPORT # : EB6K010

APPLICANT : Smart Home Engineering Corp.

ADDRESS : 10F., No. 493, Chung-Cheng Rd.,
Hsin-Tien City, Taipei 231, Taiwan, R. O. C.

Measurement procedure used:

EMI: EN 55022 Class B (1998) + A1 (2000) + A2 (2003),

EN 61000-3-2 (2006), EN 61000-3-3 (1995) + A1 (2001) + A2 (2005),

EMS: EN 55024 (1998) + A1 (2001) + A2 (2003):

IEC 61000-4-2 (2001), IEC 61000-4-3 (2002), IEC 61000-4-4 (2004), IEC 61000-4-5 (2001),

IEC 61000-4-6 (2003) + A1 (2004), IEC 61000-4-8 (2001), IEC 61000-4-11 (2004)

We hereby show that:

The measurements shown in this test report were made in accordance with the procedures given in **EUROPEAN COUNCIL DIRECTIVE 2004/108/EC**, and the energy emitted by the equipment was found to be within the limits applicable. This product, which has been issued the test report listed as above in HomeTek Technology Inc., is based on single evaluation of one sample and confirmed to comply with the requirements of the above-mentioned EMC standard.

APPROVED BY:



GRANT HUANG / Manager

TEST REPORT CERTIFICATION

EMC of electrical appliances

Report reference No. : EB6K010
 Date of issue : Dec., 15, 2007
 Applicant : Smart Home Engineering Corp.
 Address : 10F., No. 493, Chung-Cheng Rd.,
 Hsin-Tien City, Taipei 231, Taiwan, R. O. C.
 Manufacturer : Smart Home Engineering Corp.
 Type of test object : Multimedia AV Switcher
 Model/type reference : YS0XXX
 EUT Voltage : DC5V
 Test Result : Complied
 Testing laboratory : HomeTek Technology Inc.
 Address : No. 67-9, Shir Men Road, Tu Cheng City, Taipei Hsien,
 Taiwan, R. O. C.
 TEL / FAX : +886-2-22608375 / +886-2-22748013
 E-MAIL : hometek@ms15.hinet.net
 Standard : EN 55022 Class B (1998) + A1 (2000) + A2 (2003),
 EN 61000-3-2 (2006),
 EN 61000-3-3 (1995) + A1 (2001) + A2 (2005),
 EN 55024 (1998) + A1 (2001) + A2 (2003):
 IEC 61000-4-2 (2001), IEC 61000-4-3 (2002),
 IEC 61000-4-4 (2004), IEC 61000-4-5 (2001),
 IEC 61000-4-6 (2003) + A1 (2004), IEC 61000-4-8 (2001),
 IEC 61000-4-11 (2004)

Tested by (+ signature) :

Jason Lin / Engineer

Jason Lin

Approved by (+ signature) :

GRANT HUANG / Manager

Grant Huang



TEST REPORT CERTIFICATION..... 1

TABLE OF CONTENTS..... 2

TEST REPORT CERTIFICATION..... 1

GENERAL INFORMATION..... 5

MODIFICATION LIST..... 7

CONDUCTED POWER LINE TEST 8

1 TEST INSTRUMENTS & FACILITIES..... 8

2 TEST PROCEDURE..... 8

3 TEST SETUP 9

4 CONFIGURATION OF THE EUT 11

5 EUT OPERATING CONDITION..... 13

6 LIMIT OF CONDUCTED POWER LINE EMISSION CLASS B..... 13

7 RESULT OF CONDUCTED POWER LINE TEST..... 13

8 CONDUCTED POWER LINE TEST DATA (PAGE 1)..... 14

9 CONDUCTED POWER LINE TEST DATA (PAGE 2)..... 15

10 CONDUCTED POWER LINE TEST DATA (PAGE 3)..... 16

11 CONDUCTED POWER LINE TEST DATA (PAGE 4)..... 17

RADIATED EMISSION TEST..... 18

1 TEST INSTRUMENTS & FACILITIES..... 18

2 TEST PROCEDURE..... 19

3 TEST SETUP 19

4 CONFIGURATION OF THE EUT 21

5 EUT OPERATING CONDITION..... 21

6 LIMIT OF RADIATED EMISSION CLASS B 21

7 RESULT OF RADIATED EMISSION TEST..... 21

8 RADIATED EMISSION TEST DATA (PAGE 1)..... 22

9 RADIATED EMISSION TEST DATA (PAGE 2)..... 23

HARMONICS TEST..... 24

1 TEST INSTRUMENTS & FACILITIES..... 24

2 TEST PROCEDURE..... 24

3 TEST SETUP 24

4 CONFIGURATION OF THE EUT 24

5 OPERATION CONDITION OF EUT 24

6 TEST DATA & LIMIT..... 24

7 HARMONICS TEST DATA (PAGE 1~2)..... 25

VOLTAGE FLUCTUATIONS TEST 27

1 TEST INSTRUMENTS & FACILITIES..... 27

2 TEST PROCEDURE..... 27

3 TEST SETUP 27



4 CONFIGURATION OF THE EUT 27

5 OPERATION CONDITION OF EUT 27

6 TEST DATA & LIMIT 27

7 VOLTAGE FLUCTUATIONS TEST DATA (PAGE 1) 28

ELECTROSTATIC DISCHARGE IMMUNITY TEST (ESD) 29

1 TEST INSTRUMENTS & FACILITIES 29

2 TEST PROCEDURE 29

3 TEST SETUP 29

4 CONFIGURATION OF THE EUT 30

5 EUT OPERATION CONDITION 30

6 TEST CONDITION 30

7 PERFORMANCE CRITERIA 30

8 TEST RESULT 31

RADIO FREQUENCY ELECTROMAGNETIC FIELD IMMUNITY TEST (RF) 32

1 TEST INSTRUMENTS & FACILITIES 32

2 TEST PROCEDURE 32

3 TEST SETUP 33

4 CONFIGURATION OF THE EUT 34

5 OPERATION CONDITION OF EUT 34

6 TEST CONDITION 34

7 PERFORMANCE CRITERIA 34

8 TEST RESULT 35

ELECTRICAL FAST TRANSIENT/BURST IMMUNITY TEST (EFT) 36

1 TEST INSTRUMENTS & FACILITIES 36

2 TEST PROCEDURE 36

3 TEST SETUP 36

4 CONFIGURATION OF THE EUT 37

5 OPERATION CONDITION OF EUT 37

6 TEST CONDITION 37

7 PERFORMANCE CRITERIA 37

8 TEST RESULT 38

SURGE IMMUNITY TEST 39

1 TEST INSTRUMENTS & FACILITIES 39

2 TEST PROCEDURE 39

3 TEST SETUP 39

4 TEST LEVELS 40

5 CONFIGURATION OF THE EUT 40

6 EUT OPERATION CONDITION 40

7 CONDITIONS DURING TESTING 40

8 PERFORMANCE CRITERIA 41



9 TEST RESULT 41

IMMUNITY TEST TO CS CONDUCTED DISTURBANCE 42

1 TEST INSTRUMENTS & FACILITIES..... 42

2 TEST PROCEDURE..... 42

3 TEST SETUP 43

4 TEST LEVELS..... 44

5 CONFIGURATION OF THE EUT 44

6 EUT OPERATION CONDITION..... 44

7 CONDITIONS DURING TESTING..... 44

8 PERFORMANCE CRITERIA 45

9 TEST RESULT 45

POWER FREQUENCY MAGNETIC FIELD IMMUNITY TEST 46

1 TEST INSTRUMENTS & FACILITIES..... 46

2 TEST STANDARD..... 46

3 TEST SETUP 46

4 TEST LEVELS..... 47

5 CONFIGURATION OF THE EUT 47

6 OPERATION CONDITION OF EUT..... 47

7 CONDITIONS DURING TESTING..... 47

8 PERFORMANCE CRITERIA 47

9 TEST RESULTS 48

VOLTAGE DIPS, SHORT INTERRUPTIONS IMMUNITY TEST 49

1 TEST INSTRUMENTS & FACILITIES..... 49

2 TEST PROCEDURE..... 49

3 TEST SETUP 49

4 TEST LEVELS..... 50

5 CONFIGURATION OF THE EUT 50

6 EUT OPERATION CONDITION..... 50

7 CONDITIONS DURING TESTING..... 50

8 PERFORMANCE CRITERIA 51

9 TEST RESULT 51

APPENDIX A

PHOTOS OF TEST CONFIGURATION

APPENDIX B

PHOTOS OF EUT

GENERAL INFORMATION

- 1 APPLICANT : Smart Home Engineering Corp.
- 2 ADDRESS : 10F., No. 493, Chung-Cheng Rd.,
Hsin-Tien City, Taipei 231, Taiwan, R. O. C.
- 3 MANUFACTURER : Smart Home Engineering Corp.
- 4 ADDRESS : 10F., No. 493, Chung-Cheng Rd.,
Hsin-Tien City, Taipei 231, Taiwan, R. O. C.
- 5 DESCRIPTION OF EUT :
- EUT : Multimedia AV Switcher
- Model : YS0XXX
- Serial # : N/A

5.1 The difference between series of models YS0XXX are as shown below:

- (1) The first “X” represents different system input.
- (2) The second “X” represent different accessory.
- (3) The third “X” represent different color.

The PCB layout is similar. The worst case of EMC test data were shown in this test report.

6 FEATURES OF EUT :

4 Input 1 Output Component Video Switcher With Stereo Audio.

- HDTV Compatible at 480I/480p/720p/1080I.
- Connect up to 4/VV sources to one display.
- Expends both stereo audio and video input.
- The switcher box is the ideal for all of devices offering.
both high-definition video and audio switching capability.
- 1R remote control included.

7 TEST MODE :

The EUT were investigated with eight modes shown as below :

- (1) AV1 in and AV1 out Mode;
- (2) AV2 in and AV1 out Mode;
- (3) AV3 in and AV1 out Mode;
- (4) AV4 in and AV1 out Mode;
- (5) AV1 in and AV2 out Mode;
- (6) AV2 in and AV2 out Mode;
- (7) AV3 in and AV2 out Mode;
- (8) AV4 in and AV2 out Mode

The test mode of (3) AV3 in and AV1 out Mode is worst case, and the final test data were shown in this test report.

MODIFICATION LIST

THE FOLLOWING ACCESSORIES WERE ADDED TO THE EUT DURING TESTING :

NO MODIFICATION BY HOMETEK TECHNOLOGY INC.

CONDUCTED POWER LINE TEST

1 TEST INSTRUMENTS & FACILITIES

The following test Instruments was used during the conducted test :

Item	Instruments/ Facilities	Specification	Manufacturer	Model #	Date Of Cal.
1	EMI Receiver	9KHz ~ 30MHz	ROHDE & SCHWARZ	ESHS10 840449/001	DEC/2006
2	LISN (for EUT)	50Ω/50uH/16A 9KHz ~ 30MHz	AFJ	LT32 32039930056	DEC/2006
3	LISN (for Support Unit)	50Ω/50uH/15A 150KHz ~ 30MHz	SANKI	LISN1-15V 080404E	DEC/2006
4	Terminator	50Ω	N/A	N/A	DEC/2006
5	Attenuation	50Ω/10dB	Mini-Circuit	NAT-10 AT-002	DEC/2006
6	Cable	5.4m	SUHNER	RG-223 CON2-001	DEC/2006
7	ESXS-K1 (software)	Version 2.03b 9KHz ~ 30MHz	ROHDE & SCHWARZ	1082.9678.02 840.913/246	N/A

Note : Items 1 ~ 6 were calibrated within period of 1 year.

2 TEST PROCEDURE

- 2.1 The EUT was tested according to **EN55022 Class B**.
- 2.2 The EUT was placed 0.4 meter from the conducting wall of shielding room and kept at least 0.8 meter from any other grounded conducting surface.
- 2.3 The frequency range form 0.15 MHz to 30 MHz was investigated.
- 2.4 The LISN used was 50 Ohm / 50 uHenry as specified by **EN55022**.
- 2.5 All the support peripherals are connect to the other LISN.
- 2.6 Cables and peripherals were moved to find the maximum emission levels for each frequency.

3 TEST SETUP

3.1 Typical : Setup Of Conducted Test

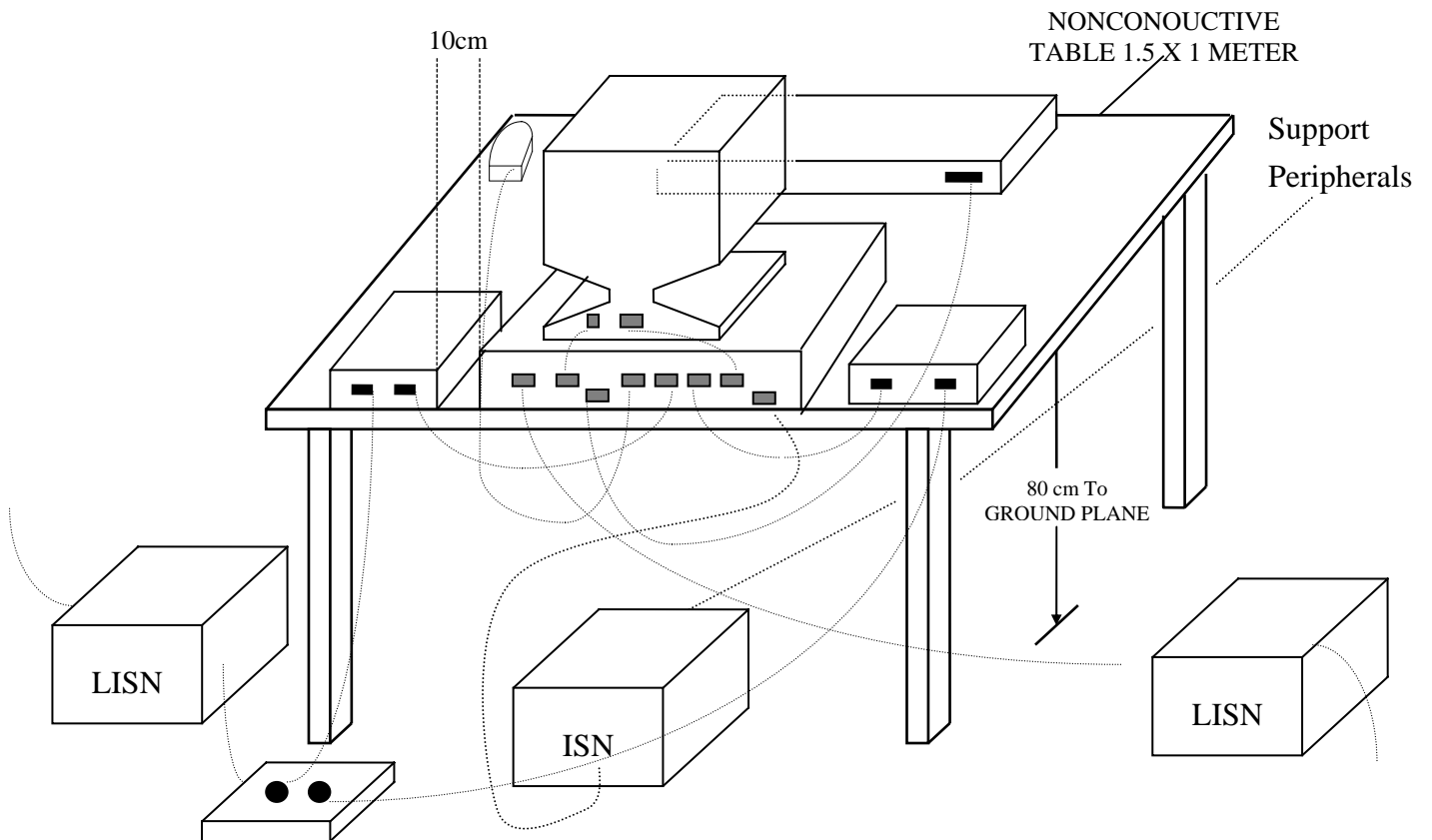

(Details for setup configuration, please refer to appendix A.)

3.2 Block Diagram Of Conducted Test

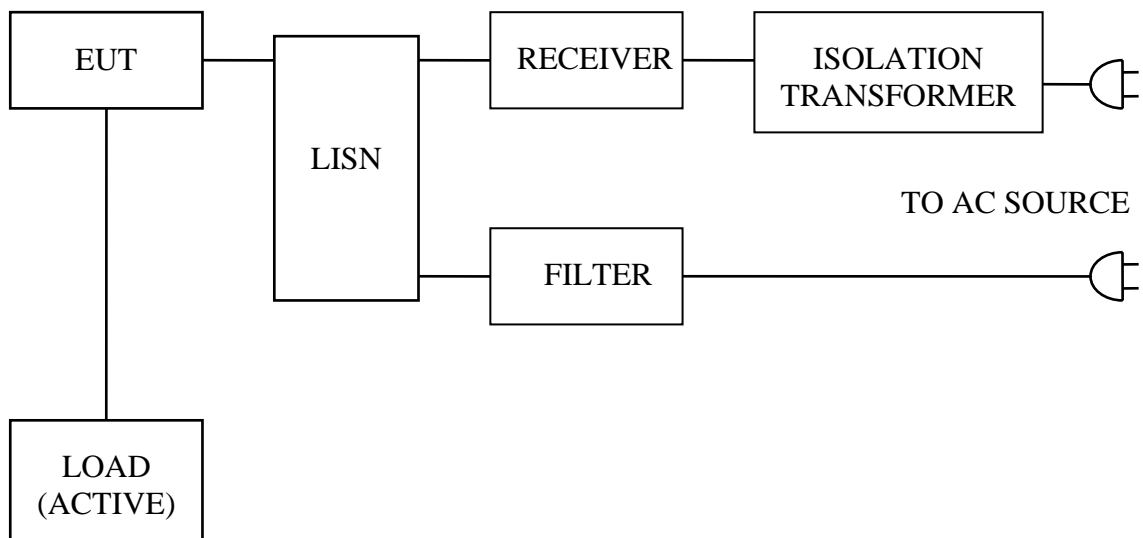

- DVD Player
- TV
- Power Adapter



4 CONFIGURATION OF THE EUT

The EUT was configured according to **EN55022**. All I/O ports were connected to the appropriate peripherals. All peripherals and cables are listed below (including internal device) :

4.1 EUT

EUT Type	: <input type="checkbox"/> Proto Type <input checked="" type="checkbox"/> Engineer Type <input type="checkbox"/> Mass Production
Condition when received	: <input checked="" type="checkbox"/> Good <input type="checkbox"/> Damage : _____
Device	: Multimedia AV Switcher
Applicant	: Smart Home Engineering Corp.
Manufacturer	: Smart Home Engineering Corp.
Model Number	: YS0XXX
Serial Number	: N/A
FCC ID	: N/A
Y In Cable x4	: Shielded, 1.5 m, Metal Type Connector
Y Out Cable x2	: Shielded, 1.5 m, Metal Type Connector
Audio In Cable x8	: Shielded, 1.7 m, Metal Type Connector
Audio Out Cable x4	: Shielded, 1.7 m, Metal Type Connector
Pb In Cable x4	: Shielded, 1.5 m, Metal Type Connector
Pb Out Cable x2	: Shielded, 1.5 m, Metal Type Connector
Pr In Cable x4	: Shielded, 1.5 m, Metal Type Connector
Pr Out Cable x2	: Shielded, 1.5 m, Metal Type Connector
Power Cord (AC)	: Direct-plug in, 2 pin
Power Cord (DC)	: Un-Shielded, 1.75 m
Power Supply Type	: Switching Power Adapter
	:

4.2 PERIPHERALS

DVD Player

Manufacturer : Philips
Model Number : DVP5960193
Serial Number : N/A
FCC ID : FCC DoC
Power Cord : Un-Shielded, 1.5 m

TV

Manufacturer : SAMSUNG
Model Number : LA26R51B
Serial Number : N/A
FCC ID : FCC DoC
Power Cord : Un-Shielded, 1.5 m

Power Adapter

Manufacturer : ELEC
Model Number : ADP051200R-2
Serial Number : N/A
FCC ID : N/A
Data Cable : N/A
Power Cord (DC) : Un-Shielded, 1.75 m

4.3 REMARK : N/A

5 EUT OPERATING CONDITION

- 5.1 The frequency of the EUT is none.
- 5.2 Configure the EUT according to the **ANSI C63.4 - 2003 & CISPR 22 - 1997**.
- 5.3 The test configuration included DVD Player, TV and Power Adapter.
- 5.4 Turn on all the power of EUT and peripheral.
- 5.5 Playing the DVD.
- 5.6 Adjust the location of EUT and peripheral to gain the maximum EMI noise.
- 5.7 The photos of conducted test configuration, please refer to appendix A.**

6 LIMIT OF CONDUCTED POWER LINE EMISSION CLASS B

Frequency Range	Quasi Peak	Average
0.15 ~ 0.5 MHz	66 - 56 dBuV	56 - 46 dBuV
0.5 ~ 5 MHz	56 dBuV	46 dBuV
5 ~ 30 MHz	60 dBuV	50 dBuV

7 RESULT OF CONDUCTED POWER LINE TEST

- 7.1 The frequency range from 0.15 MHz to 30 MHz was investigated. All readings are quasi-peak values and average.
- 7.2 IF bandwidth : 9 kHz, Meas Time : 1 sec.
- 7.3 Temperature : 23.6 °C, Humidity : 54 % RH.
- 7.4 Deviations from the test standards and rules : None.
- 7.5 The conducted test result were gained by following procedures :
 Level = Reading Level + Insertion Loss of LISN + Cable Loss
 (All calculation were done by ESHS10 EMI test receiver.)
- 7.6 Result : **PASSED**

8 CONDUCTED POWER LINE TEST DATA (PAGE 1)

HomeTek EMC LAB. TEL :86-769-85303005 , 886-2-22608375

10 Dec 2007 14:08

CONDUCTED EMISSIONS

EUT: YS04A
 Manuf: 6K010
 Op Cond: UNE
 Operator: FELIX
 Test Spec: FOR EN55022 CLASS B
 Comment: 230V/50Hz
 AV3 IN and AV1 OUT MODE
 Result File: 6K0100021.dat

Prescan Measurement: Detectors: X PK / + AV
 Meas Time: see scan settings
 Subranges: 8
 Acc Margin: 55 dB

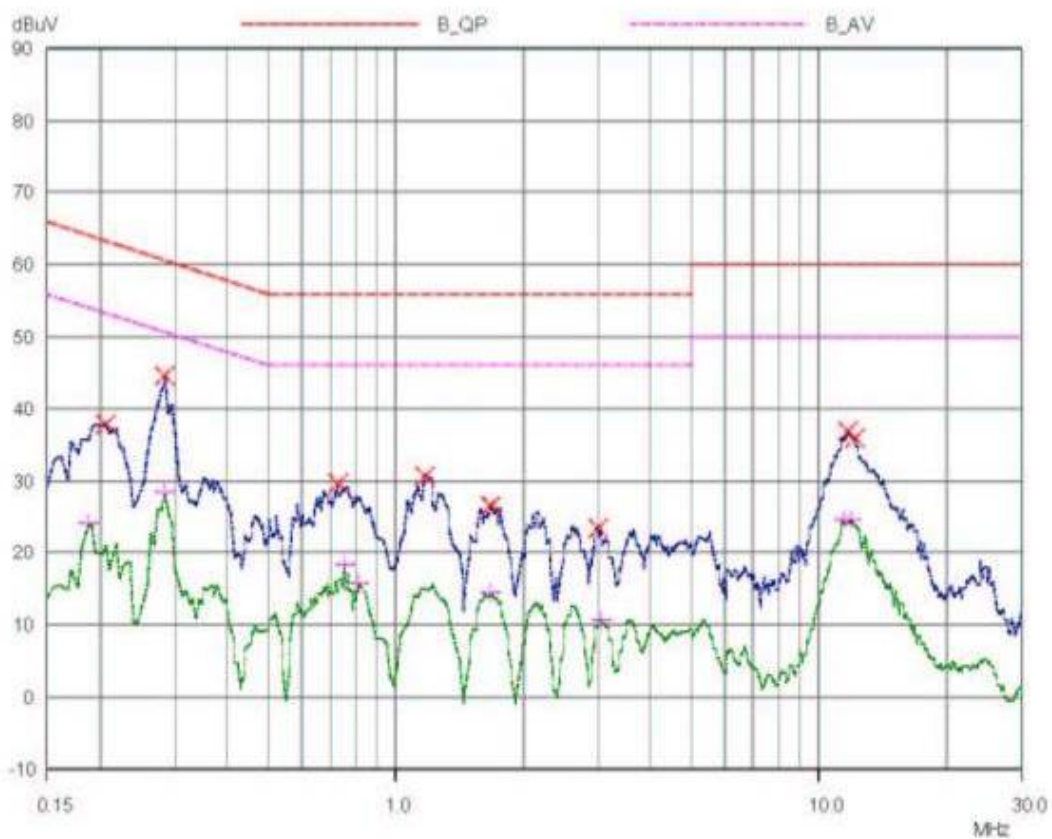



9 CONDUCTED POWER LINE TEST DATA (PAGE 2)

HomeTek EMC LAB. TEL :86-769-85303005 , 886-2-22608375
CONDUCTED EMISSIONS

10 Dec 2007 14:08

EUT: YS04A
Manuf: 6K010
Op Cond: LINE
Operator: FELIX
Test Spec: FOR EN55022 CLASS B
Comment: 230V/50Hz
AV3 IN and AV1 OUT MODE
Result File: 6K0100021.dat

Prescan Measurement: Detectors: X PK / + AV
Meas Time: see scan settings
Subranges: 8
Acc Margin: 55 dB

Peak Search Results

Frequency MHz	PK Level dBuV	PK Limit dBuV	PK Delta dB
0.205	37.87	63.41	25.54
0.285	44.67	60.67	16.00
0.723	29.78	56.00	26.22
1.16	30.63	56.00	25.37
1.68	26.54	56.00	29.46
2.98	23.45	56.00	32.55
11.64	36.99	60.00	23.01
12.06	36.00	60.00	24.00

Frequency MHz	AV Level dBuV	AV Limit dBuV	AV Delta dB
0.185	24.25	54.26	30.01
0.285	28.53	50.67	22.14
0.749	18.44	46.00	27.56
0.82	15.77	46.00	30.23
1.68	14.55	46.00	31.45
3.04	10.79	46.00	35.21
11.4	24.62	50.00	25.38
12.0	24.65	50.00	25.35

* limit exceeded

10 CONDUCTED POWER LINE TEST DATA (PAGE 3)

HomeTek EMC LAB. TEL :86-769-85303005 , 886-2-22608375

10 Dec 2007 14:23

CONDUCTED EMISSIONS

EUT: YS04A
 Manuf: 6K010
 Cp Cond: NEUTRAL
 Operator: FELIX
 Test Spec: FOR EN55022 CLASS B
 Comment: 230V/50Hz
 AV3 IN and AV1 OUT MODE
 Result File: 6K0100022.dat

Prescan Measurement: Detectors: X PK / + AV
 Meas Time: see scan settings
 Subranges: 8
 Acc Margin: 55 dB

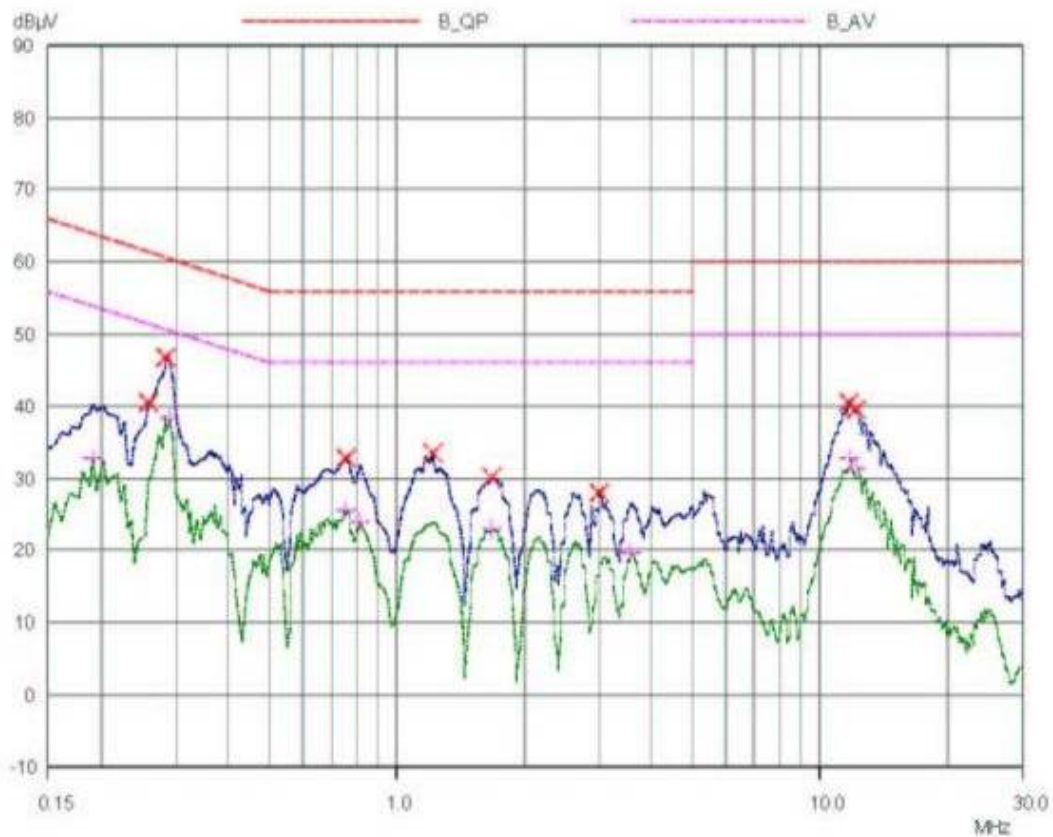



11 CONDUCTED POWER LINE TEST DATA (PAGE 4)

HomeTek EMC LAB. TEL :86-769-85303005 , 886-2-22608375

10 Dec 2007 14:23

CONDUCTED EMISSIONS

EUT: YS04A
 Manuf: 6K010
 Op Cond: NEUTRAL
 Operator: FELIX
 Test Spec: FOR EN55022 CLASS B
 Comment: 230V/50Hz
 AV3 IN and AV1 OUT MODE
 Result File: 6K0100022.dat

Prescan Measurement: Detectors: X PK / + AV
 Meas Time: see scan settings
 Subranges: 8
 Acc Margin: 55 dB

Peak Search Results

Frequency MHz	PK Level dBuV	PK Limit dBuV	PK Delta dB
0.255	40.57	61.59	21.02
0.285	46.84	60.67	13.83
0.7555	32.96	56.00	23.04
1.2	33.47	56.00	22.53
1.66	30.27	56.00	25.73
3.0	28.11	56.00	27.89
11.76	40.43	60.00	19.57
12.12	39.60	60.00	20.40

Frequency MHz	AV Level dBuV	AV Limit dBuV	AV Delta dB
0.19	32.82	54.04	21.22
0.29	38.34	50.52	12.18
0.7555	25.63	46.00	20.37
0.82	24.02	46.00	21.98
1.68	23.00	46.00	23.00
3.58	19.56	46.00	26.44
11.76	32.74	50.00	17.26
12.12	31.47	50.00	18.53

* limit exceeded

RADIATED EMISSION TEST

1 TEST INSTRUMENTS & FACILITIES

The following test Instruments was used during the radiated emission test :

Item	Instruments /facilities	Specification	Manufacturer	Model # / S/N#	Date of Cal.
1	OPEN AREA TEST SITE	<input checked="" type="checkbox"/> OATS 3	HomeTek	N/A	DEC/2006
2	EMI TEST RECEIVER	20Hz ~ 5GHz	ROHED& SCHWARZ	ESBI 845636/007	DEC/2006
3	PRE-AMPLIFIER	9KHz ~1300MHz	HEWLETT PACKARD	8447D 1937A02095	DEC/2006
4	ANTENNA (BI-LOG)	30MHz ~ 2GHz	ANTENNA RESEACH	LPB2520/A 1095	MAR/2007
5	Attenuation	50Ω/6dB	JYE BAO	FAT-N(M-F) 001	DEC/2006
6	Cable	10m	SUHNER	RG214/U OS3-003	DEC/2006
7	Cable	14m	BELDEN	9913 OS3-001	DEC/2006
8	EMI 32 (software)	N/A	AUDIX	19991013-0923	N/A

Note : Items 1 ~ 7 were calibrated within period of 1 year.

2 TEST PROCEDURE

- 2.1 The EUT was test according to **EN55022**.
- 2.2 The radiated test was performed at HomeTek Lab's Open Site 3.
- 2.3 The frequency range from 30 MHz to 1 GHz, the measurement were made at 10 meters, with a BI-log antenna.

3 TEST SETUP

3.1 TEST SETUP OF OPEN SITE.

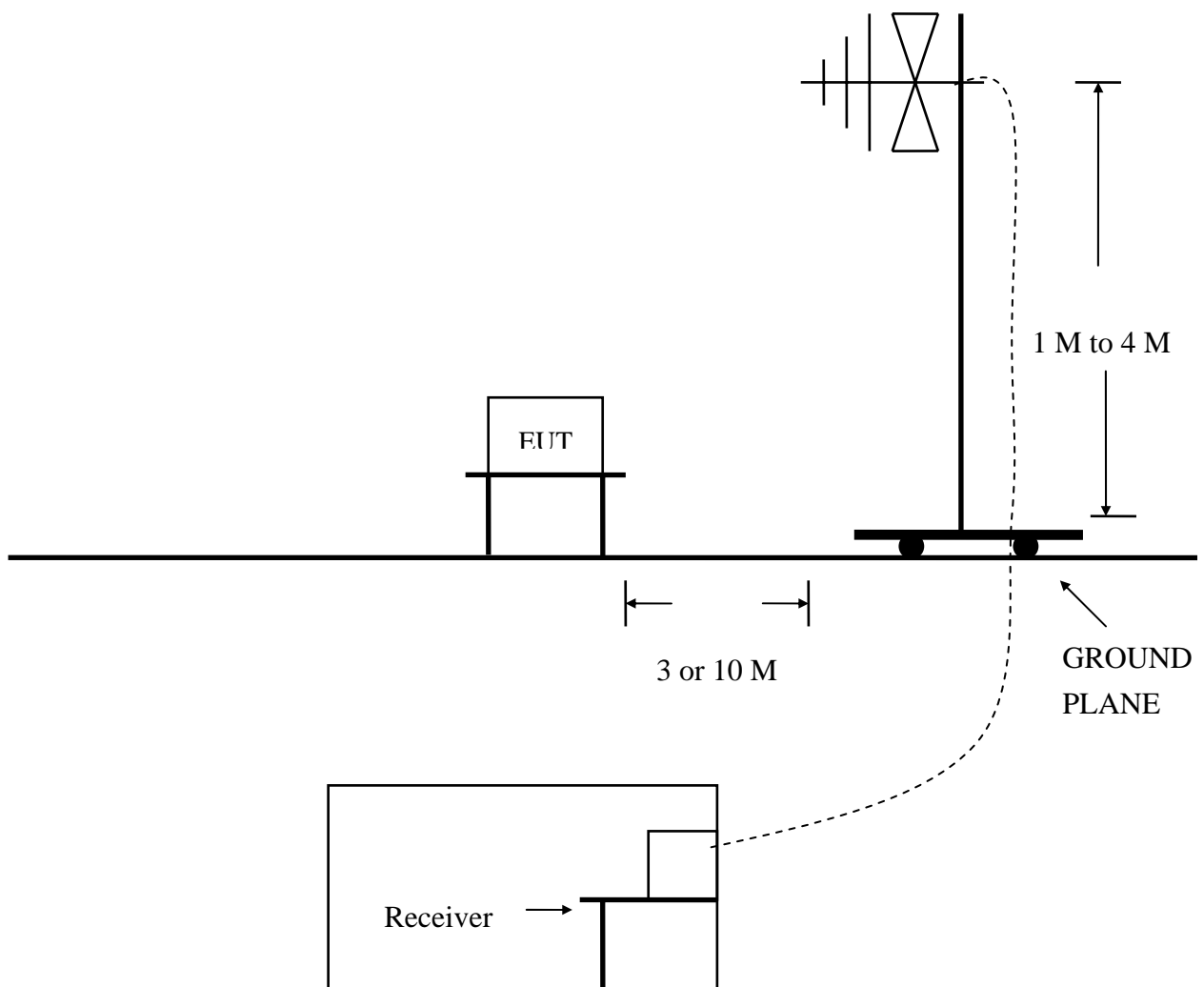

(Details for setup configuration, please refer to appendix A.)

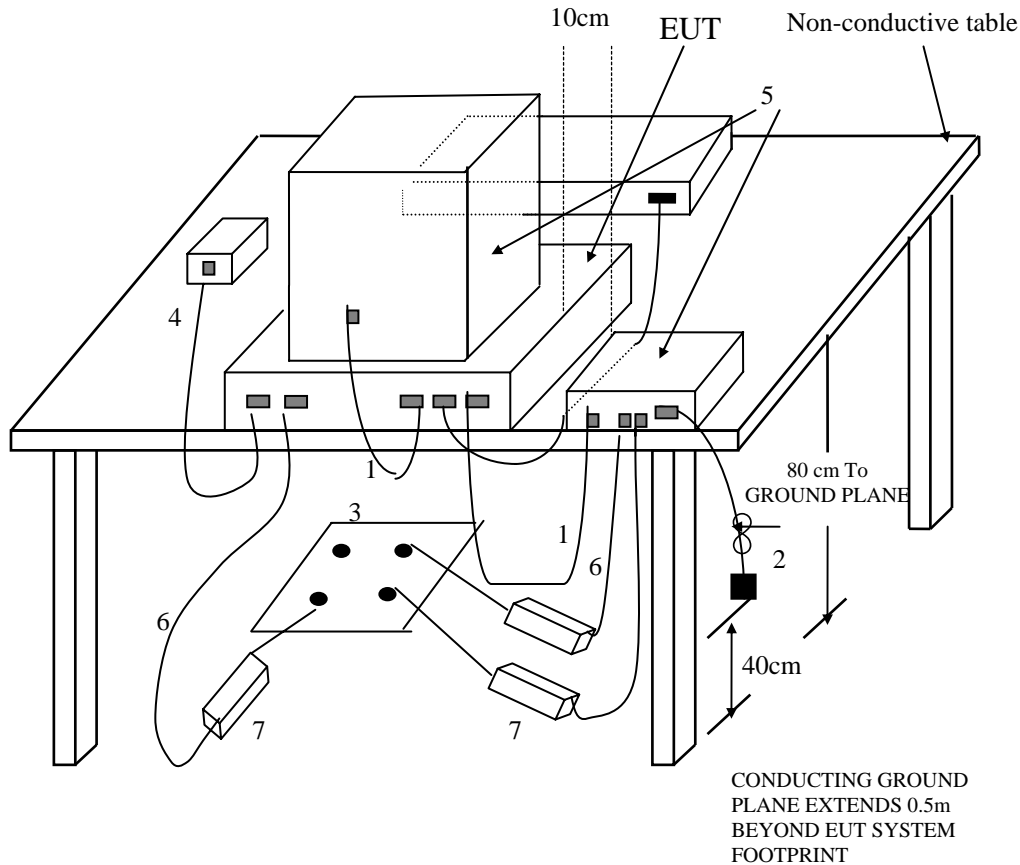

(Details for setup configuration, please refer to appendix A.)

LEGEND:

- 1.If cables, which hang closer than 40 cm to the horizontal metal ground plane cannot be shortened to the appropriate length, the excess shall be folded back and forth forming a bundle 30 cm to 40 cm long.
- 2.The end of I/O signal cables which are not connected to a peripheral may be terminated, if required for proper operation using correct terminating impedance.
- 3.Mains junction box(es) shall be flush with, and bonded directly to, the metal ground plane.
NOTE if used, the AMN shall be installed under the horizontal metal ground plane.
- 4.Cables of hand-operated devices such as keyboards, mice, etc. shall be placed as for normal usage.
- 5.Peripherals shall be placed at a distance of 10 cm from each other and from the controller, except for the monitor which, if for an acceptable installation practice, shall be placed directly on top of the controller.
- 6.Mains cables, telephone lines or other connections to auxiliary equipment located outside the test area shall drape to the floor, be fitted with ferrite clamps or ferrite tubes placed on the floor at the point where the cable reaches the floor and then routed to the place where they leave the turntable. No extension cords shall be used to mains receptacle.
- 7.Ferrite clamps or ferrite tubes with similar characteristics (as defined in 10.4). No more than one cable per clamp.

Test Configuration

Tabletop Equipment Radiated Measurement

4 CONFIGURATION OF THE EUT

Same as “Conducted Power Line test”, section 4

5 EUT OPERATING CONDITION

5.1 Same as “Conducted Power Line test”, section 5

5.2 The radiated emission in the frequency range from 30 MHz - 1000 MHz was test in a horizontal and vertical polarization at HomeTek Lab’s open site 3.

5.3 The photos of radiated test configuration, please refer to appendix A.

6 LIMIT OF RADIATED EMISSION CLASS B

Frequency (MHz)	Measurement Distance	Limit (dBuV/m)
30 - 230	10 (M)	30
230 - 1000	10 (M)	37

7 RESULT OF RADIATED EMISSION TEST

7.1 The frequency range from 30 MHz to 1 GHz was investigated.

7.2 All readings below or equal 1 GHz are quasi-peak or peak values with resolution bandwidth of 120 KHz.

7.3 The measurements were made at 10 meters of HomeTek Lab’s open site 3.

7.4 Temperature : 23.1 °C, Humidity : 54 % RH.

7.5 Deviation form the test standards and rules : None.

7.6 The radiated emission result were gained by the following method :

Level = Reading Level + Probe Factor (Antenna Factor) + Cable Loss – Preamp Factor
 Over Limit = Level – Limit Line

7.7 Result : **PASSED**

8 RADIATED EMISSION TEST DATA (PAGE 1)



HomeTek Technology Inc.

HomeTek Technology Inc.
 Tel:02-22608375
 Fax:02-22748013

Data#: 5 File#: 6K010.EMI

Date: 2007-12-10 Time: 11:00:37

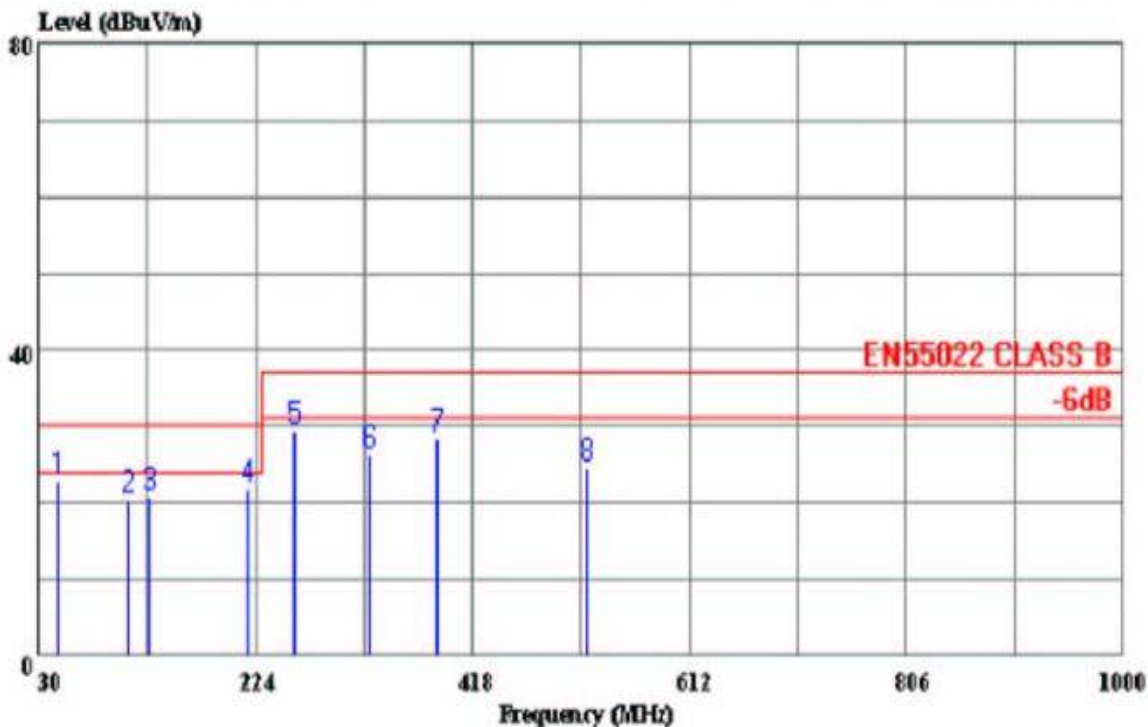

Trace:

Ref Trace:

Condition: EN55022 CLASS B 10m LPB-250/A-031028 HORIZONTAL
 out : YS04A
 power: 230V/50Hz
 memo : AV3 IN and AV1 OUT MODE

Page: 1

	Freq	Level	Limit	Over	Read		
	MHz	dBuV/m	dBuV/m	Limit	Level	Factor	Remark
				dB	dBuV	dB	
1	47.460	23.00	30.00	-7.00	36.70	-13.70	Peak
2	110.510	20.34	30.00	-9.66	38.80	-18.46	QP
3	128.940	20.84	30.00	-9.16	41.90	-21.06	Peak
4	216.240	21.78	30.00	-8.22	41.50	-19.72	Peak
5	257.950	29.32	37.00	-7.68	45.20	-15.88	Peak
6	325.850	26.33	37.00	-10.67	38.20	-11.87	Peak
7	386.960	28.43	37.00	-8.57	37.90	-9.47	Peak
8	519.850	24.68	37.00	-12.32	31.20	-6.52	Peak



9 RADIATED EMISSION TEST DATA (PAGE 2)



HomeTek Technology Inc.

HomeTek Technology Inc.
Tel:02-22608375
Fax:02-22748013

Data#: 6 File#: 6K010.EMI

Date: 2007-12-10 Time: 11:46:01

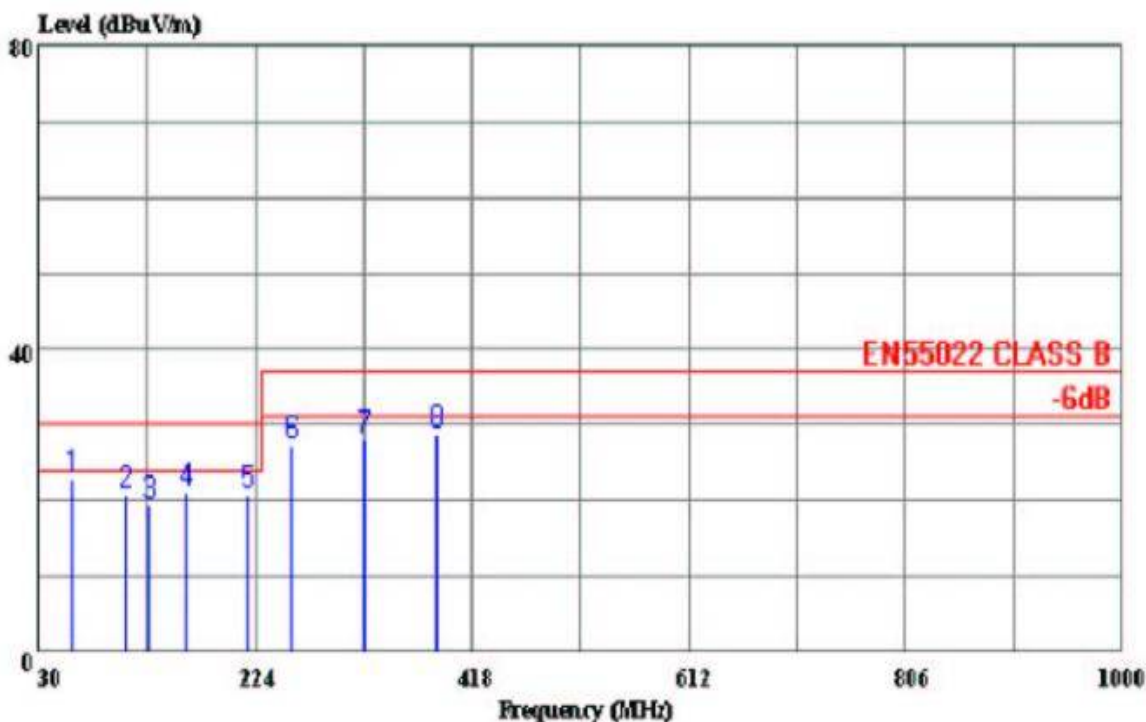

Trace:

Ref Trace:

Condition: EN55022 CLASS B 10m LPB-250/A-031028 VERTICAL
cut : YS04A
power: 230V/50Hz
memo : AV3 IN and AV1 OUT MODE

Page: 1

	Freq	Level	Limit	Over	Read		Remark
	MHz	dBuV/m	dBuV/m	dB	dBuV	dB	
1	60.070	22.93	30.00	-7.07	38.60	-15.67	Peak
2	107.600	20.83	30.00	-9.17	36.90	-16.07	QP
3	127.970	19.23	30.00	-10.77	36.50	-17.27	Peak
4	162.890	20.99	30.00	-9.01	43.20	-22.21	Peak
5	217.210	20.71	30.00	-9.29	33.70	-12.99	Peak
6	256.980	27.39	37.00	-9.61	42.40	-15.01	Peak
7	321.000	28.14	37.00	-8.86	34.80	-6.66	Peak
8	386.960	28.73	37.00	-8.28	38.80	-10.08	Peak

HARMONICS TEST

1 TEST INSTRUMENTS & FACILITIES

Instruments/ facilities	Manufacturer	Model # Serial #	Date of Cal.
POWER FREQUENCY TEST SYSTEM	HAEFELY	PHF555 080419-12	JAN/2007
CONTROL PC	KB TECH	KB P586/133	N/A

Note : Item 1 were calibrated with two years and verified before testing.

2 TEST PROCEDURE

According to EN 61000-3-2 (2006) Class A

3 TEST SETUP

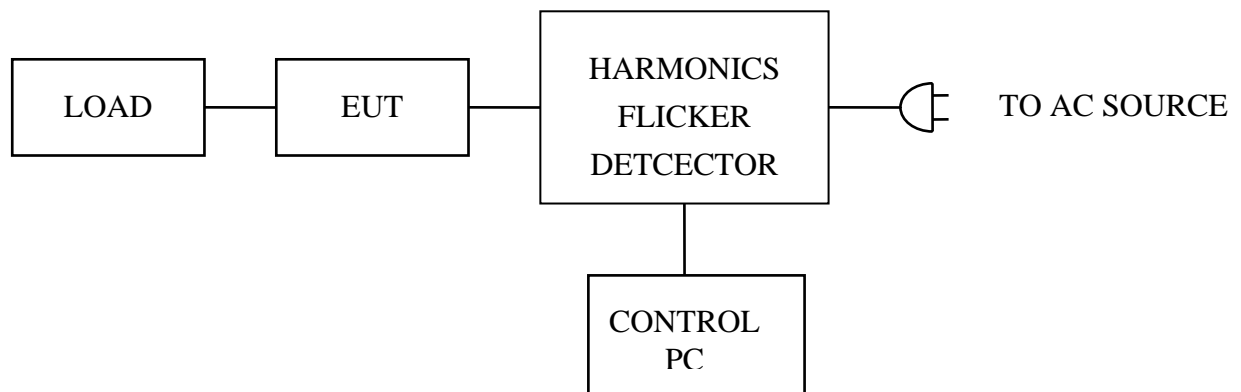

(Details for setup configuration, please refer to appendix A.)

4 CONFIGURATION OF THE EUT

Same as “Conducted Power Line test”, section 4

5 OPERATION CONDITION OF EUT

Same as “Conducted Power Line test”, section 5

6 TEST DATA & LIMIT

6.1 Temperature : 23.2 °C

6.2 Humidity : 59 % RH



7 HARMONICS TEST DATA (PAGE 1~2)

EN 61000-3-2 TEST REPORT 2007/12/10 8:55 PM

Unit : Multimedia AV Switcher
Serial No. : YS04A
Remarks : AV 3 IN and AV 1 OUT MODE
Operator: FELIX

TEST SETUP

Test Freq.: 50.00 Hz. Test Voltage: 230.0 vac
Waveform : SINE Test Time: 15 min.
Classification : CLASS A Test Type: STEADY-STATE
Prog. Zo Enabled: YES Prog. Zo: 0.000
Motor Driven with Phase Angle Control: NO
Impedance selected: DIRECT
Synthetic R+L Enabled: NO
Resistance: 0.400 Ohms Inductance: 795.775 uH

TEST DATA

Result: PASS

Harmonic Current Results

Harmonic Voltage Results

Table with 8 columns: Hn, AMPS, LO Limit, HI Limit, Result, %Fund., Limit, Result. Rows 0-9 showing harmonic test results.



10	0.000	0.276	0.276	PASS	0.001	0.200	PASS
11	0.001	0.495	0.495	PASS	0.003	0.100	PASS
12	0.000	0.230	0.230	PASS	0.001	0.100	PASS
13	0.000	0.315	0.315	PASS	0.003	0.100	PASS
14	0.000	0.197	0.197	PASS	0.001	0.100	PASS
15	0.001	0.225	0.225	PASS	0.001	0.100	PASS
16	0.000	0.172	0.172	PASS	0.001	0.100	PASS
17	0.000	0.199	0.199	PASS	0.001	0.100	PASS
18	0.000	0.153	0.153	PASS	0.001	0.100	PASS
19	0.000	0.178	0.178	PASS	0.002	0.100	PASS
20	0.000	0.138	0.138	PASS	0.001	0.100	PASS
21	0.000	0.161	0.161	PASS	0.002	0.100	PASS
22	0.000	0.125	0.125	PASS	0.001	0.100	PASS
23	0.000	0.147	0.147	PASS	0.003	0.100	PASS
24	0.000	0.115	0.115	PASS	0.001	0.100	PASS
25	0.000	0.135	0.135	PASS	0.003	0.100	PASS
26	0.000	0.106	0.106	PASS	0.001	0.100	PASS
27	0.000	0.125	0.125	PASS	0.003	0.100	PASS
28	0.000	0.099	0.099	PASS	0.001	0.100	PASS
29	0.000	0.116	0.116	PASS	0.001	0.100	PASS
30	0.000	0.092	0.092	PASS	0.001	0.100	PASS
31	0.000	0.109	0.109	PASS	0.002	0.100	PASS
32	0.000	0.086	0.086	PASS	0.001	0.100	PASS
33	0.000	0.102	0.102	PASS	0.003	0.100	PASS
34	0.000	0.081	0.081	PASS	0.001	0.100	PASS
35	0.000	0.096	0.096	PASS	0.002	0.100	PASS
36	0.000	0.077	0.077	PASS	0.001	0.100	PASS
37	0.000	0.091	0.091	PASS	0.001	0.100	PASS
38	0.000	0.073	0.073	PASS	0.000	0.100	PASS
39	0.000	0.087	0.087	PASS	0.002	0.100	PASS
40	0.000	0.069	0.069	PASS	0.001	0.100	PASS

PAGE 2
END OF REPORT

VOLTAGE FLUCTUATIONS TEST

1 TEST INSTRUMENTS & FACILITIES

Instruments/ facilities	Manufacturer	Model # Serial #	Date of Cal.
POWER FREQUENCY TEST SYSTEM	HAEFELY	PHF555 080419-12	JAN/2007
CONTROL PC	KB TECH	KB P586/133	N/A

Note : Item 1 were calibrated with two years and verified before testing.

2 TEST PROCEDURE

According to EN 61000-3-3 (1995) + A1 (2001) + A2 (2005)

3 TEST SETUP

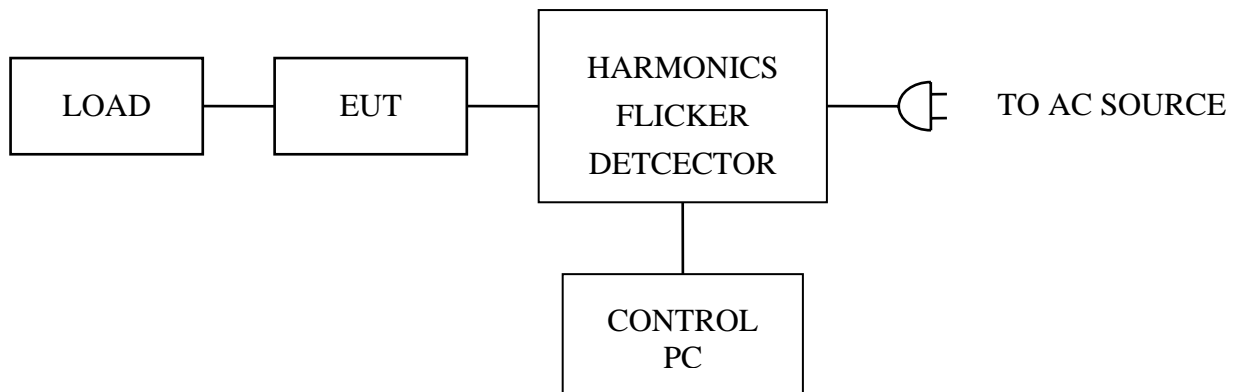

(Details for setup configuration, please refer to appendix A.)

4 CONFIGURATION OF THE EUT

Same as “Conducted Power Line test”, section 4

5 OPERATION CONDITION OF EUT

Same as “Conducted Power Line test”, section 5

6 TEST DATA & LIMIT

6.1 Temperature : 23.2 °C

6.2 Humidity : 59 % RH



7 VOLTAGE FLUCTUATIONS TEST DATA (PAGE 1)

EN 61000-3-3 TEST REPORT 2007/12/10 8:06 PM

Unit : Multimedia AV Switcher
Serial No. : YS04A
Remarks : AV 3 IN AV 1 OUT MODE
Operator: FELIX

TEST SETUP

Test Freq.: 50.00 Hz. Test Voltage: 230.0 vac
Waveform : SINE
Test Time: 15 min. Tshort: 15 min.
Prog. Zo Enabled: YES Prog. Zo: 0.000
Voltage Change less than once per Hour: NO
Impedance selected: DIRECT
Synthetic R+L Enabled: NO
Resistance: 0.400 Ohms Inductance: 795.775 uH

TEST DATA

Result: PASS

Table with 5 columns: EUT Data, Limit, Result, Test Enabled. Rows include Pst max, Plt max, dc %, dmax %, d(t) sec.

Power Source Data

Table with 5 columns: EUT Data, Limit, Result, Test Enabled. Rows include Source Pst max, % THD.

PAGE 1
END OF REPORT

ELECTROSTATIC DISCHARGE IMMUNITY TEST (ESD)

1 TEST INSTRUMENTS & FACILITIES

Instruments/ Facilities	Manufacturer	Model # Serial #	Data Of Cal.
ESD TESTER	NOISEKEN	ESS-2002 ESS05033971	DEC/2006
VCP	HOMETEK	--	--

2 TEST PROCEDURE

According to **IEC 61000-4-2 (2001)**

According to **EN 55024 (1998) + A1 (2001) + A2 (2003)**

3 TEST SETUP

TABLE SIZE

160L X 80W X 80H cm

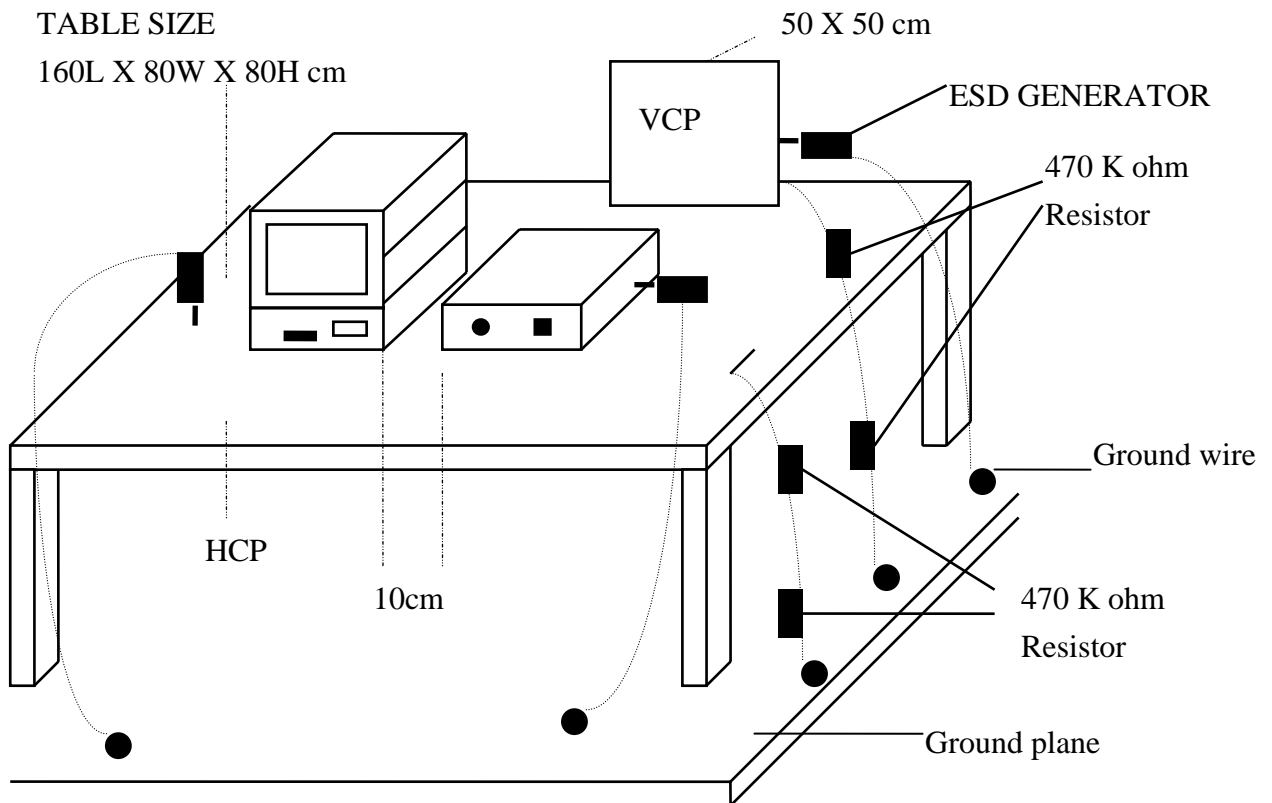

(Details for setup configuration, please refer to appendix A.)

4 CONFIGURATION OF THE EUT

Same as “Conducted Power Line test”, section 4

5 EUT OPERATION CONDITION

Same as “Conducted Power Line test”, section 5

6 TEST CONDITION

6.1 Test Level :

(A) ± 2 , ± 4 , ± 8 KV for air discharge.

(B) ± 2 , ± 4 KV for contact discharge.

6.2 Number of test : 10 Discharges / Test point / Polarity / Level

Particular requirements : at least 200 discharges, 100 each at negative and positive polarity, at a minimum of four test points.

6.3 Time between test : 1 sec.

6.4 Temperature : 22.7 °C

6.5 Humidity : 48 % RH.

7 PERFORMANCE CRITERIA

- A. The apparatus shall continue to operate as intended during and after the test. No degradation of performance or loss of function is allowed below a performance level specified by the manufacturer, when the apparatus is used as intended.
- B. The apparatus shall continue to operate as intended after the test. No degradation of performance or loss of function is allowed below a performance level specified by the manufacturer, when the apparatus is used as intended. The performance level may be replaced by a permissible loss of performance. During the test, degradation of performance is however allowed.
- C. Temporary loss of function is allowed, provided the function is self-recoverable or can be restored by the operation of the controls.

8 TEST RESULT

Test Point	Air Discharge	Contact Discharge	Performance Criteria	Result
HCP	---	$\pm 2, \pm 4KV$	B	PASSED
VCP	---	$\pm 2, \pm 4KV$	B	PASSED
CASE	$\pm 2, \pm 4, \pm 8KV$	$\pm 2, \pm 4KV$	B	PASSED
I/O PORTS	$\pm 2, \pm 4, \pm 8KV$	$\pm 2, \pm 4KV$	B	PASSED
LED	$\pm 2, \pm 4, \pm 8KV$	$\pm 2, \pm 4KV$	B	PASSED
BUTTON	$\pm 2, \pm 4, \pm 8KV$	$\pm 2, \pm 4KV$	B	PASSED
SCREWS	$\pm 2, \pm 4, \pm 8KV$	$\pm 2, \pm 4KV$	B	PASSED
DC SOCKET	$\pm 2, \pm 4, \pm 8KV$	$\pm 2, \pm 4KV$	B	PASSED

RADIO FREQUENCY ELECTROMAGNETIC FIELD IMMUNITY TEST (RS)

1 TEST INSTRUMENTS & FACILITIES

Item	Instruments Facilities	Manufacturer	Model # Serial #	Data Of Cal.
1	SIGNAL GENERATOR	MARCONI INSTRUMENTS	2022D 119229/010	DEC/2006
2	AMPLIFIER	KALMUS	7100LC-CE 748813-2	DEC/2006
3	FIELD SENSOR	AMPLIFIER RESEARCH	FP2000	DEC/2006
4	FIELD MONITOR	AMPLIFIER RESEARCH	FM2000	DEC/2006
5	RF VOLTMETER	BOONTON	9200C 354201AA	DEC/2006
6	RF PROBE	BOONTON	952001B 37082	DEC/2006
7	DIRECTION COUPLER	WERLATON	G2630 4795	DEC/2006
8	ANTENNA	EMCO	3810/2NM S/N:9701-1763	DEC/2006
9	CONTROL PC	KB TECH	KB P586/133	--

Note : Items 3 ~ 4 were calibrated with two years and verified before testing.

2 TEST PROCEDURE

According to **IEC 61000-4-3 (2002)**

According to **EN 55024 (1998) + A1 (2001) + A2 (2003)**

3 TEST SETUP

FERRITE TILE

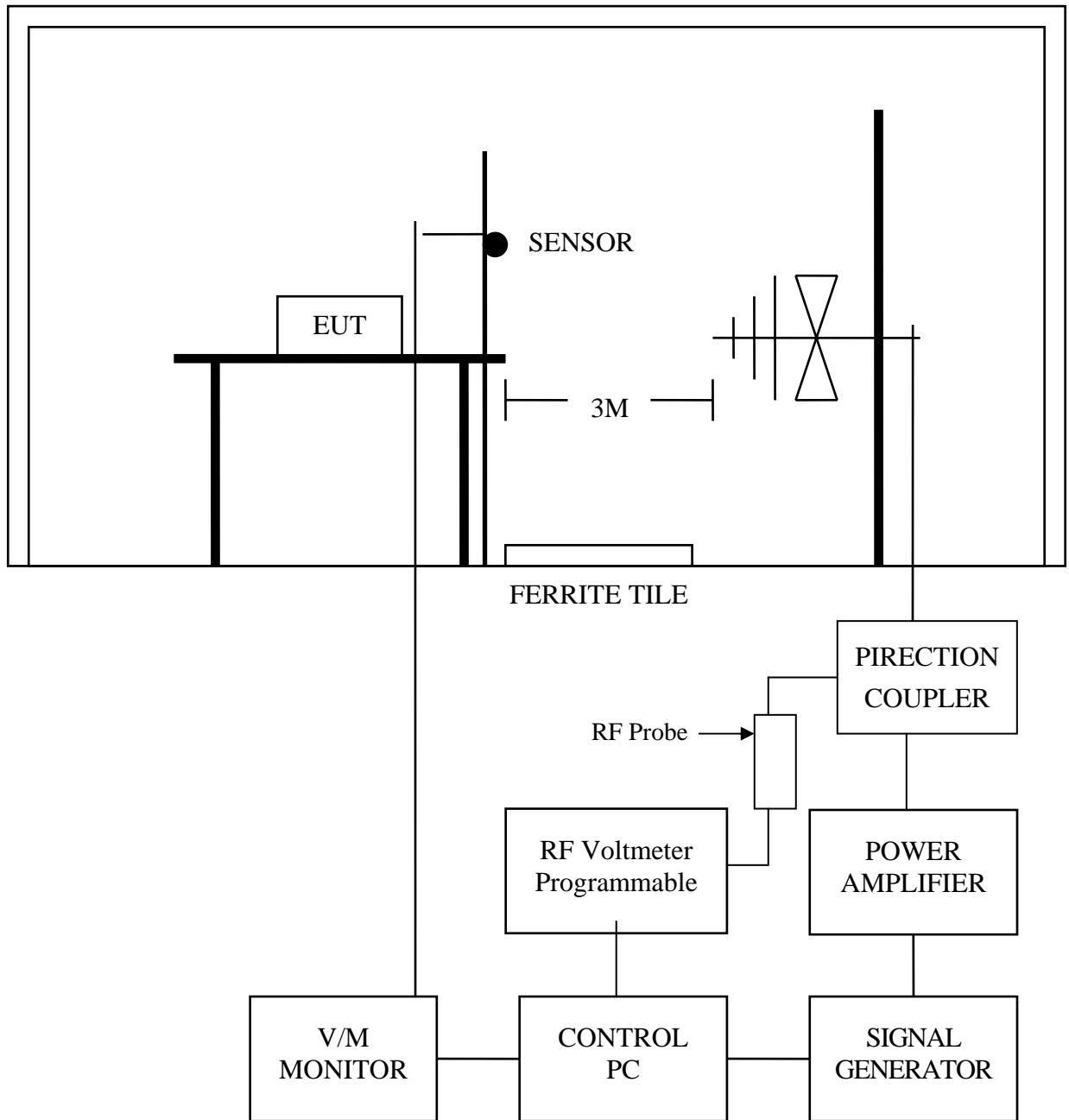

3.1 Chamber Size :

12M x 5M x 5M

(Details for setup configuration, please refer to appendix A.)

4 CONFIGURATION OF THE EUT

Same as “Conducted Power Line test”, section 4

5 OPERATION CONDITION OF EUT

Same as “Conducted Power Line test”, section 5

6 TEST CONDITION

6.1 Frequency Range : 80 MHz ~ 1000 MHz

(Frequency Range : 1.4 GHz ~ 2.0 GHz is not applicable for EN55024:1998+A1:2001+A2:2003)

6.2 Filed Strength : 3 V / M (1KHz 80% Modulation)

6.3 Frequency Step : 1 %, 3 sec. / each step size

6.4 Antenna Polarity : HORIZONTAL & VERTICAL

6.5 The four sides of EUT are tested
(FRONT, REAR, RIGHT, LEFT)

6.6 Temperature : 22.8 °C

6.7 Humidity : 48 % RH

7 PERFORMANCE CRITERIA

- A. The apparatus shall continue to operate as intended during and after the test. No degradation of performance or loss of function is allowed below a performance level specified by the manufacturer, when the apparatus is used as intended.
- B. The apparatus shall continue to operate as intended after the test. No degradation of performance or loss of function is allowed below a performance level specified by the manufacturer, when the apparatus is used as intended. The performance level may be replaced by a permissible loss of performance. During the test, degradation of performance is however allowed.
- C. Temporary loss of function is allowed, provided the function is self-recoverable or can be restored by the operation of the controls.

8 TEST RESULT

ANT SIDE	HORIZONTAL	VERTICAL	RESULT
FRONT	A	A	PASSED
REAR	A	A	PASSED
RIGHT	A	A	PASSED
LEFT	A	A	PASSED

ELECTRICAL FAST TRANSIENT/BURST IMMUNITY TEST (EFT)

1 TEST INSTRUMENTS & FACILITIES

Instruments/ Facilities	Manufacturer	Model # Serial #	Data Of Cal.
BURST-TESTER	EMC PARTNER	TRANSIENT-1000 TRA1000-317	DEC/2006
CONTROL PC	KB TECH	KB P586/133	--

2 TEST PROCEDURE

According to **IEC 61000-4-4 (2004)**

According to **EN 55024 (1998) + A1 (2001) + A2 (2003)**

3 TEST SETUP

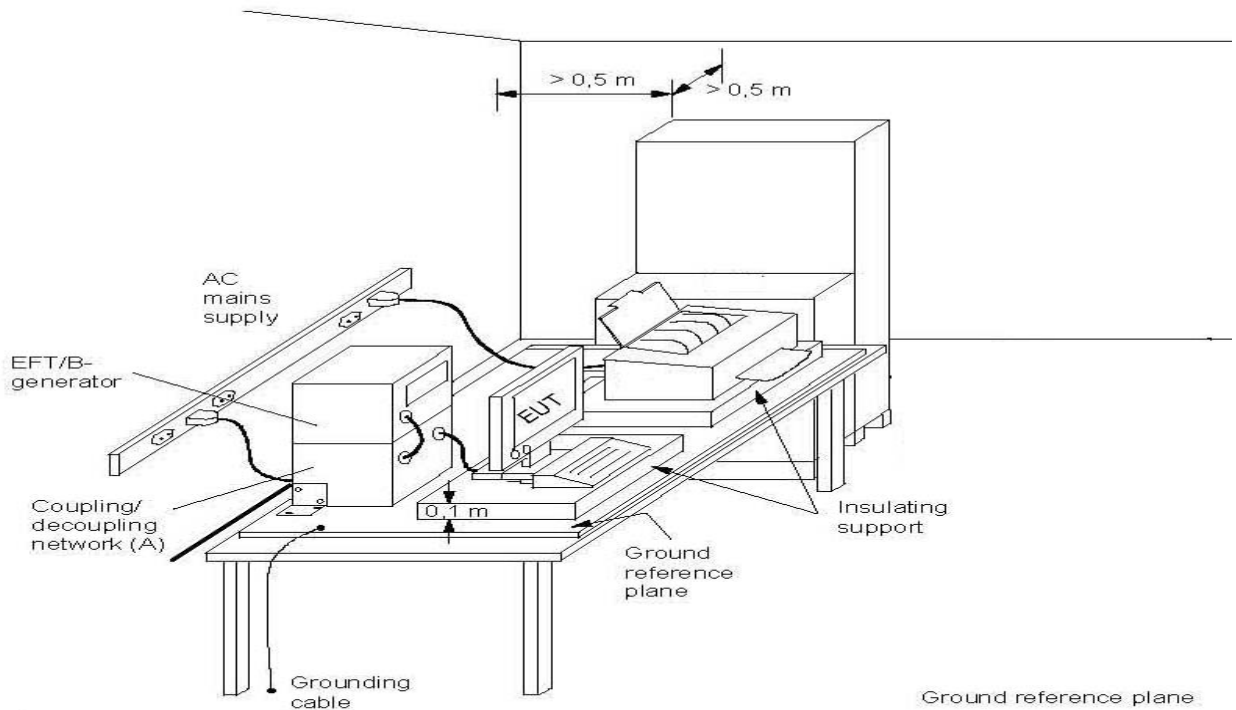

(Details for setup configuration, please refer to appendix A.)

Note: length between clamp and the EUT to be tested (should be $0.5\text{ m} \pm 0.05\text{ m}$)

(A) location for supply line coupling

(B) location for signal line coupling

4 CONFIGURATION OF THE EUT

Same as “Conducted Power Line test”, section 4

5 OPERATION CONDITION OF EUT

Same as “Conducted Power Line test”, section 5

6 TEST CONDITION

6.1 Pulse Rise time & Duration : 5 nS / 50 nS

6.2 Pulse Repetition : 5 kHz

6.3 Polarity : POSITIVE / NEGATIVE

6.4 Test Voltage : $\pm 0.5\text{KV}$, $\pm 1\text{KV}$

6.5 Coupling of power line :

L, N, L+N

6.6 Temperature : 22.6 °C

6.7 Humidity : 49 % RH

7 PERFORMANCE CRITERIA

- A. The apparatus shall continue to operate as intended during and after the test. No degradation of performance or loss of function is allowed below a performance level specified by the manufacturer, when the apparatus is used as intended.
- B. The apparatus shall continue to operate as intended after the test. No degradation of performance or loss of function is allowed below a performance level specified by the manufacturer, when the apparatus is used as intended. The performance level may be replaced by a permissible loss of performance. During the test, degradation of performance is however allowed.
- C. Temporary loss of function is allowed, provided the function is self-recoverable or can be restored by the operation of the controls.

8 TEST RESULT

TEST VOLTAGE	L	N	L+N
$\pm 0.5\text{KV}$	A	A	A
$\pm 1\text{KV}$	A	A	A

8.1 Model : YS04A8.2 Test Mode : AV3 in and AV1 out Mode8.3 Final Result : PASSED

8.4 Remark :

SURGE IMMUNITY TEST

1 TEST INSTRUMENTS & FACILITIES

Instruments/ Facilities	Manufacturer	Model # Serial #	Data Of Cal.
BURST-TESTER	EMC PARTNER	TRANSIENT-1000 TRA1000-317	DEC/2006
CONTROL PC	KB TECH	KB P586/133	--

2 TEST PROCEDURE

According To **IEC 61000-4-5 (2001)**

According To **EN 55024 (1998) + A1 (2001) + A2 (2003)**

3 TEST SETUP

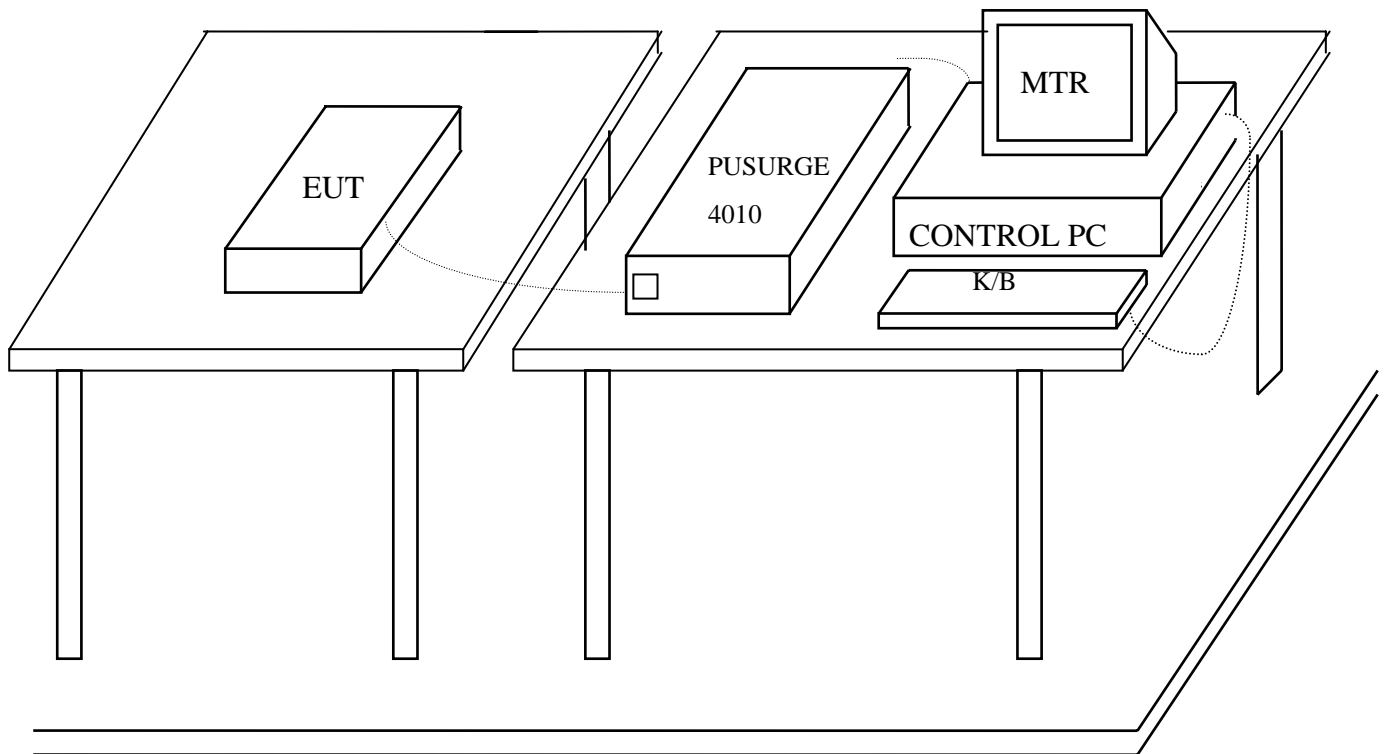

GROUND PLANE

(Details for setup configuration, please refer to appendix A.)

4 TEST LEVELS

- Input and Output AC Power Ports.
- DC Input and DC Output Power Ports.

Environmental Phenomena	Test Specification		Units	Performance Criteria
	AC	DC		
Surges	1.2 / 50 (8/20)		Tr /Th us	
Line to Line	±1	±0.5	KV (Charge Voltage)	B

5 CONFIGURATION OF THE EUT

Same as “Conducted Power Line test”, section 4

6 EUT OPERATION CONDITION

Same as “Conducted Power Line test”, section 5

7 CONDITIONS DURING TESTING

7.1 Coupling of power line :

(A) Line to Line ±1KV (AC) or ±0.5KV (DC)

7.2 Polarity : POSITIVE / NEGATIVE

7.3 Phase shifting in a range between 0° to 360°

7.4 Repletion rate at least 1 per min

7.5 Temperature : 23.5 °C (15°C ~ 35°C)

Humidity : 48 % RH.(10 % ~ 75%)

8 PERFORMANCE CRITERIA

- A. The apparatus shall continue to operate as intended during and after the test. No degradation of performance or loss of function is allowed below a performance level specified by the manufacturer, when the apparatus is used as intended.
- B. The apparatus shall continue to operate as intended after the test. No degradation of performance or loss of function is allowed below a performance level specified by the manufacturer, when the apparatus is used as intended. The performance level may be replaced by a permissible loss of performance. During the test, degradation of performance is however allowed.
- C. Temporary loss of function is allowed, provided the function is self-recoverable or can be restored by the operation of the controls.

9 TEST RESULT

Environmental Phenomena	Test Specification	Units	Performance
Line to Line	± 1	KV (Charge Voltage)	A

9.1 Model : YS04A

9.2 Test Mode : AV3 in and AV1 out Mode

9.3 Final Result : PASSED

9.4 Remark :

IMMUNITY TEST TO CS CONDUCTED DISTURBANCE

1 TEST INSTRUMENTS & FACILITIES

Instruments/ Facilities	Manufacturer	Model # Serial #	Date Of Cal.
SIGNAL GENERATOR	MARCONI INSTRUMENTS	2022D 119229/010	DEC/2006
AMPLIFIER	KALMUS	7100LC-CE	DEC/2006
RF VOLTMETER	BOONTON	9200C 354201AA	DEC/2006
RF PROBE	BOONTON	952001B 37082	DEC/2006
DIRECTION COUPLER	WERLATON	G2630 4795	DEC/2006
COUPLING DECOUPLING NETWORK	ELECTRO-METRICS	EM-7801 103	DEC/2006
CONTROL PC	KB TECH	KB P586/133	--

2 TEST PROCEDURE

According To **IEC 61000-4-6 (2003) + A1 (2004)**

According To **EN 55024 (1998) + A1 (2001) + A2 (2003)**

3 TEST SETUP

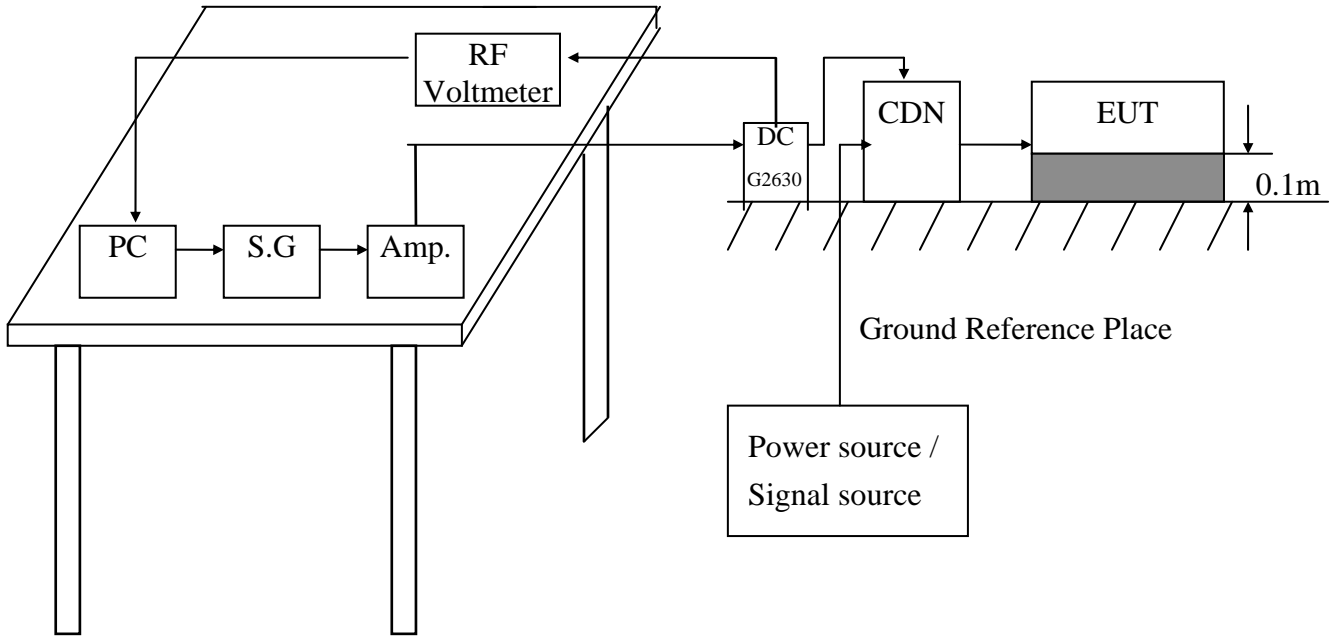

(Details for setup configuration, please refer to appendix A.)

4 TEST LEVELS

- Ports for signal lines and control lines.
- DC input and DC output power ports.
- Input and Output AC Power Ports.
- Functional earth Ports.

Environmental	Test Specification	Units	Performance
Radio-frequency	0.15 - 80	MHz	
Common mode	3	V	A
	80	% AM (1KHz)	

5 CONFIGURATION OF THE EUT

Same as “Conducted Power Line test”, section 4

6 EUT OPERATION CONDITION

Same as “Conducted Power Line test”, section 5

7 CONDITIONS DURING TESTING

7.1 The EUT tested type :

- Single unit
- Multiple unit

7.2 Dwell time : < 1%

7.3 Temperature : 23.4 °C (15°C ~ 35°C)

Humidity : 50 % RH.(10 % ~ 75%)

8 PERFORMANCE CRITERIA

- A. The apparatus shall continue to operate as intended during and after the test. No degradation of performance or loss of function is allowed below a performance level specified by the manufacturer, when the apparatus is used as intended.
- B. The apparatus shall continue to operate as intended after the test. No degradation of performance or loss of function is allowed below a performance level specified by the manufacturer, when the apparatus is used as intended. The performance level may be replaced by a permissible loss of performance. During the test, degradation of performance is however allowed.
- C. Temporary loss of function is allowed, provided the function is self-recoverable or can be restored by the operation of the controls.

9 TEST RESULT

TEST Specification	Unit	Performance Criteria
0.15 - 80	MHz	A
3	V	
80	% AM (1KHz)	

9.1 Model : YS04A

9.2 Test Mode : AV3 in and AV1 out Mode

9.3 Final Result : PASSED

9.4 Remark :

POWER FREQUENCY MAGNETIC FIELD IMMUNITY TEST

1 TEST INSTRUMENTS & FACILITIES

Instruments/ Facilities	Manufacturer	Model # Serial #	Data Of Cal.
LINE INTERFERENCE TESTER	HAEFELY	PLINE 1610 080166-10	FEB/2007
MAGNETIC FIELD TESTER	HAEFELY	MAG 100.1 080206-01	N/A
TRIAXIAL ELF MAGNETIC FIELD METER	F.W.BELL	4080 9645	AUG/2007
CONTROL PC	KB TECH	KB P586/133	--

2 TEST STANDARD

According To **IEC 61000-4-8 (2001)**

According To **EN 55024 (1998) + A1 (2001) + A2 (2003)**

3 TEST SETUP

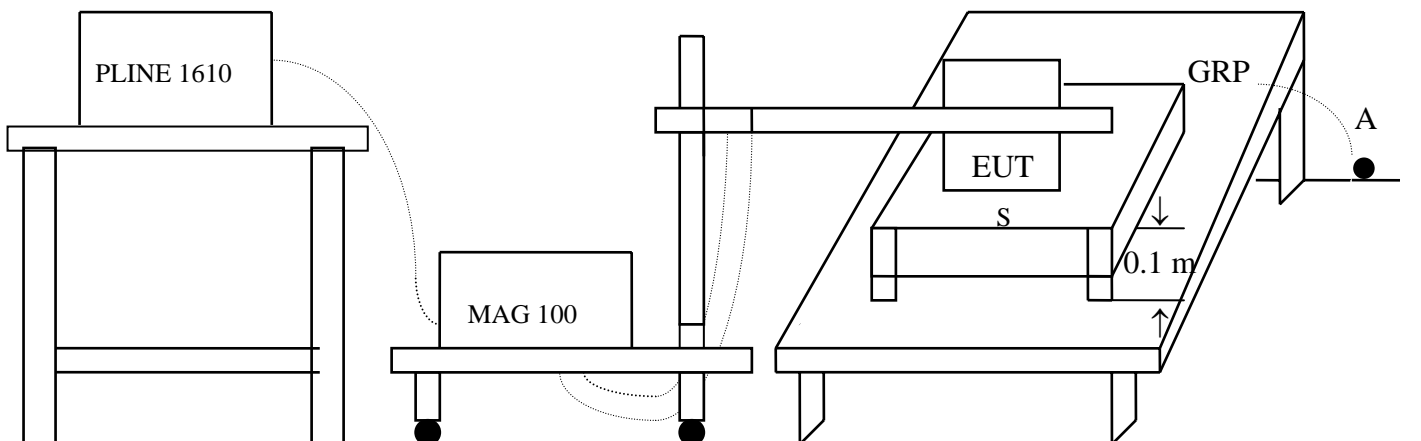

S: Insulating support

A: Safety earth

GRP: Ground plane

(Details for setup configuration, please refer to appendix A.)

4 TEST LEVELS

Environmental Phenomena	Test Specification	Units	Performance Criteria
Power Frequency	50	HZ	
Magnetic Field	1	A/m	B

5 CONFIGURATION OF THE EUT

Same as “Conducted Power Line test”, section 4

6 OPERATION CONDITION OF EUT

Same as “Conducted Power Line test”, section 5

7 CONDITIONS DURING TESTING

7.1 Temperature : 23.1 °C (15°C ~ 35°C)

Humidity : 46 % RH.(25 % ~ 75%)

7.2 The induction coil shall be rotated by 90°

8 PERFORMANCE CRITERIA

- A. The apparatus shall continue to operate as intended during and after the test. No degradation of performance or loss of function is allowed below a performance level specified by the manufacturer, when the apparatus is used as intended.
- B. The apparatus shall continue to operate as intended after the test. No degradation of performance or loss of function is allowed below a performance level specified by the manufacturer, when the apparatus is used as intended. The performance level may be replaced by a permissible loss of performance. During the test, degradation of performance is however allowed.
- C. Temporary loss of function is allowed, provided the function is self-recoverable or can be restored by the operation of the controls.

9 TEST RESULTS

Environmental Phenomena	Test Specification	Units	Performance Criteria
Magnetic Field	1	A/m	A

9.1 Model : YS04A

9.2 Test Mode : AV3 in and AV1 out Mode

9.3 Final Results : PASSED

9.4 Remark :

VOLTAGE DIPS, SHORT INTERRUPTIONS IMMUNITY TEST

1 TEST INSTRUMENTS & FACILITIES

Instruments/ Facilities	Manufacturer	Model # Serial #	Data Of Cal.
LINE INTERFERENCE -TESTER	EMC PARTNER	TRANSIENT-1000 TRA1000-317	DEC/2006
CONTROL PC	KB TECH	KB P586/133	--

2 TEST PROCEDURE

According To **IEC 61000-4-11 (2004)**

According To **EN 55024 (1998) + A1 (2001) + A2 (2003)**

3 TEST SETUP

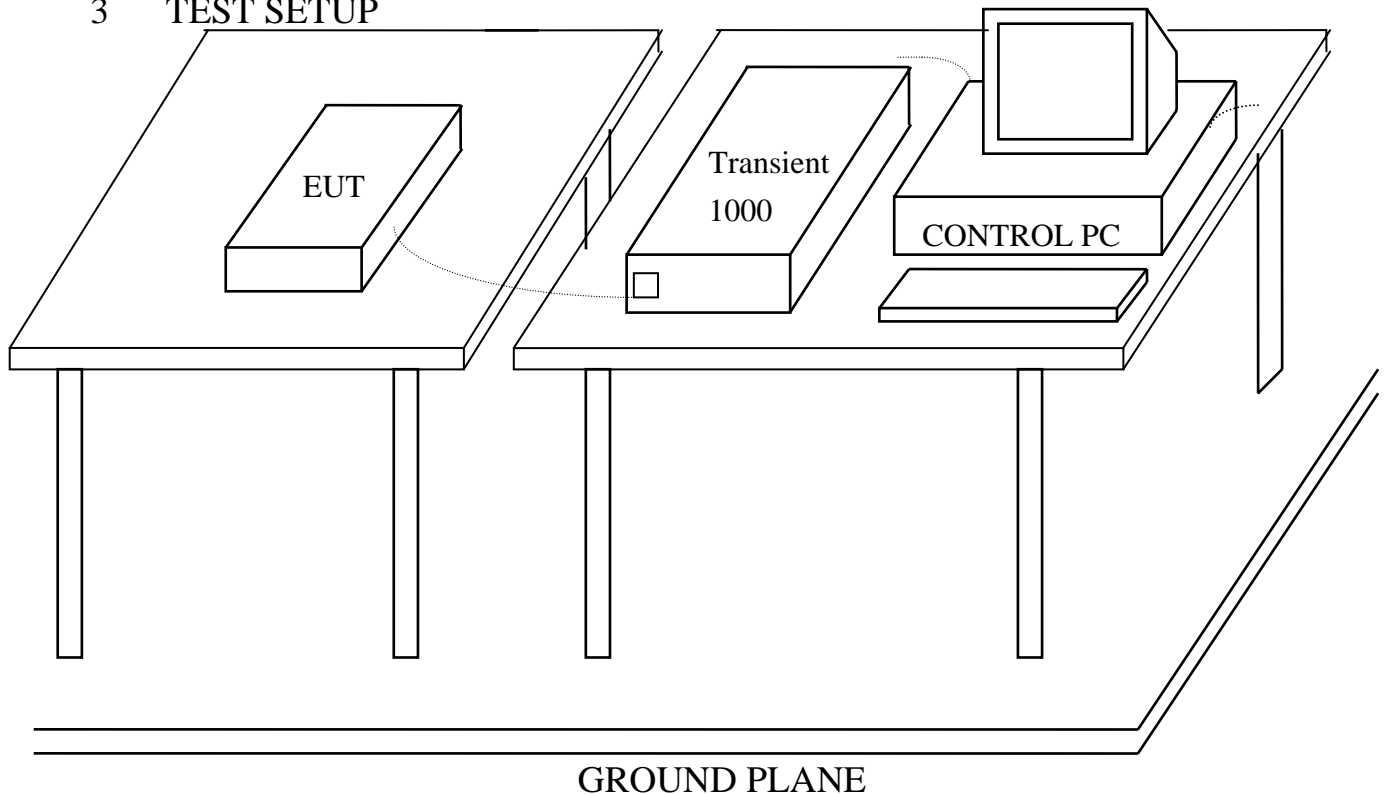

(Details for setup configuration, please refer to appendix A.)

4 TEST LEVELS

Input and Output AC Power Ports.

- Voltage Dips.
- Voltage Interruptions.

Class ^a	Test level and durations for voltage dips				
Class 1	Case-by-case according to the equipment requirements				
Class 2	0 % during 1/2 cycle	0 % during 1 cycle	70 % during 25/30 ^c cycles		
Class 3	0 % during 1/2 cycle	0 % during 1 cycle	40 % during 10/12 ^c cycles	70 % during 25/30 ^c cycles	80 % during 250/300 ^c cycles
a: Classes as per IEC 61000-2-4. b: To be defined by product committee. For equipment connected directly or indirectly to the public network, the levels must not be less severe than Class 2. c: “25/30 cycles” means “25 cycles for 50 Hz test” and “30 cycles for 60 Hz tet”.					

Class ^a	Test level and durations for short interruptions (t _s) (50Hz / 60Hz)
Class 1	Case-by-case according to the equipment requirements
Class 2	0 % during 250/300 ^c cycles
Class 3	0 % during 250/300 ^c cycles
Class X ^b	X
a: Classes as per IEC 61000-2-4. b: To be defined by product committee. For equipment connected directly or indirectly to the public network, the levels must not be less severe than Class 2. c: “250/300 cycles” means “250 cycles for 50 Hz test” and “300 cycles for 60 Hz test”.	

✳ **According to the specification of EUT, Class 2 is applied.**

5 CONFIGURATION OF THE EUT

Same as “Conducted Power Line test”, section 4

6 EUT OPERATION CONDITION

Same as “Conducted Power Line test”, section 5

7 CONDITIONS DURING TESTING

7.1 Temperature : 22.8 °C (15°C ~ 35°C)

Humidity : 57 % RH.(25 % ~ 75%)

8 PERFORMANCE CRITERIA

- A. The apparatus shall continue to operate as intended during and after the test. No degradation of performance or loss of function is allowed below a performance level specified by the manufacturer, when the apparatus is used as intended.
- B. The apparatus shall continue to operate as intended after the test. No degradation of performance or loss of function is allowed below a performance level specified by the manufacturer, when the apparatus is used as intended. The performance level may be replaced by a permissible loss of performance. During the test, degradation of performance is however allowed.
- C. Temporary loss of function is allowed, provided the function is self-recoverable or can be restored by the operation of the controls.

9 TEST RESULT

Environmental Phenomena	Test Specification	Units	Perform Criteria
Voltage Dips	0 1/2	% during Cycle	B
	0 1	% during Cycle	B
	70 25	% during Cycles	C
Voltage Short Interruptions	0	% during	C
	250	Cycles	

9.1 Model : YS04A

9.2 Test Mode : AV3 in and AV1 out Mode

9.3 Final Results : PASSED

9.4 Remark :



HomeTek Technology Inc.

Appendix A

PHOTOS OF TEST CONFIGURATION

PHOTO OF CONDUCTED POWER LINE TEST



Front View

PHOTO OF RADIATED EMISSION TEST



Front View



HomeTek Technology Inc.

Appendix B

PHOTOS OF EUT

PHOTO OF EUT



Front View of EUT



Rear View of EUT



Inside View of EUT



Full View of Adapter

Declaration of Conformity

We(Manufacturer/Importer)

(company name)

(address)

declares under our sole responsibility that the product

Product name : Multimedia AV Switcher

Model No. : YS0XXX

to which this declaration relates is in conformity with the following standard(s) or other normative document(s)

- | | |
|---|---|
| <input checked="" type="checkbox"/> EN 55022 Class B (1998) | <input checked="" type="checkbox"/> EN 55024 (1998) |
| + A1 (2000) | + A1 (2001) |
| + A2 (2003) | + A2 (2003) |
| <input checked="" type="checkbox"/> EN 61000-3-2 (2006) | <input checked="" type="checkbox"/> IEC 61000-4-2 (2001) |
| <input checked="" type="checkbox"/> EN 61000-3-3 (1995) | <input checked="" type="checkbox"/> IEC 61000-4-3 (2002) |
| + A1 (2001) | <input checked="" type="checkbox"/> IEC 61000-4-4 (2004) |
| + A2 (2005) | <input checked="" type="checkbox"/> IEC 61000-4-5 (2001) |
| | <input checked="" type="checkbox"/> IEC 61000-4-6 (2003) |
| | + A1 (2004) |
| | <input checked="" type="checkbox"/> IEC 61000-4-8 (2001) |
| | <input checked="" type="checkbox"/> IEC 61000-4-11 (2004) |

following the provisions of 2004/108/EC Directive

Place: _____ Signature: _____

Date : _____ Full name: _____



Title: _____



TÜV Rheinland Taiwan Ltd.

Certificate of Appointment

for the applicant:

Hometek Technology Inc.
No. 67-9, Shir Men Rd., Tu-Cheng City,
Taipei Hsien 236, Taiwan, R.O.C.

has been authorized to carry out EMC tests by order and under supervision of TÜV Rheinland. It has successfully demonstrated capability to conduct measurement and to process test data according to:

**European and International EMC Standards as listed in the
Scope of Authorization on the attachment to this certificate**

An assessment of the facility was conducted by TÜV Rheinland auditors according to the TÜV Rheinland requirements for "Test Site Approval" with reference to

ISO 17025: 2005

Certificate No. : 10012161-2007

Valid until : Sept. 7, 2008

TÜV Rheinland Taiwan Ltd.
Taipei, June 20, 2007

Dipl.-Ing. Andreas Klinker
Certification Body

Dipl.-Ing. Bodo Kretzschmar
Product Safety and Quality



Attachment to
Certificate
of Appointment

SCOPE OF AUTHORIZATION

Hometek Technology Inc.
No. 67-9, Shir Men Rd., Tu-Cheng City,
Taipei Hsien 236, Taiwan, R.O.C.

European Standards

EN 50081-1	EN 61000-3-3	ENV 50140
EN 50081-2	EN 61000-6-1	ENV 50141
EN 50082-1	EN 61000-6-2	ENV 50204
EN 50130-4	EN 61000-6-3	
EN 50091-2	EN 61000-6-4	
EN 55011	EN 61000-3-11	
EN 55013	EN 61000-4-2	
EN 55014-1	EN 61000-4-3	
EN 55014-2	EN 61000-4-4	
EN 55022	EN 61000-4-5	
EN 55024	EN 61000-4-6	
EN 60601-1-2	EN 61000-4-8	
EN 60801	EN 61000-4-11	
EN 60945	EN 61204-3	
EN 61000-3-2	EN 62040-2	

International Standards

CISPR 11	IEC 61000-4-2	IEC 61000-3-2
CISPR 13	IEC 61000-4-3	IEC 61000-3-3
CISPR 14-1	IEC 61000-4-4	IEC 61000-3-11
CISPR 14-2	IEC 61000-4-5	IEC 61000-6-1
CISPR 22	IEC 61000-4-6	IEC 61000-6-2
CISPR 24	IEC 61000-4-8	IEC 61000-6-3
	IEC 61000-4-11	IEC 61000-6-4
IEC 801.2	IEC 61000-4-12	IEC 60945
IEC 801.3		IEC 62040-2
IEC 801.4		

Certificate No. : 10012161-2007

Taipei, June 20, 2007

Dipl.-Ing. Bodo Kretzschmar
Product Safety and Quality