



HomeTek Technology Inc.

ADDRESS: No. 67-9, Shir Men Road, Tu Cheng City,
Taipei Hsien, Taiwan, R. O. C.

PHONE : 886-2-22608375 FAX : 886-2-22748013

E - mail : hometek@ms15.hinet.net

CERTIFICATE OF COMPLIANCE

EUT : Video Distributor & Amplifier
MODEL NO. : CD816XXX
Receipt Date : 03/18/2004 Final Test Date: 03/30/2004
REPORT # : EB3C030
APPLICANT : SMART CABLING & TRANSMISSION CORP.
ADDRESS : 3F., No. 4, Lane 130, Min-Chung Rd.,
Hsin-Tien City, Taipei Hsien, Taiwan, R. O. C.

Measurement procedure used:

EMI: EN 55013 (2001),

EN 61000-3-2 (2000), EN 61000-3-3 (1995) + A1 (2001)

EMS: EN 61000-6-1 (2001):

IEC 61000-4-2 (1995), IEC 61000-4-3 (1995), IEC 61000-4-4 (1995), IEC 61000-4-5 (1995),
IEC 61000-4-6 (1996), IEC 61000-4-8 (1993), IEC 61000-4-11 (1994)

We hereby show that:

The measurements shown in this test report were made in accordance with the procedures given in **EUROPEAN COUNCIL DIRECTIVE 89/336/EEC**, and the energy emitted by the equipment was found to be within the limits applicable.

This test result of this report applies to above tested sample only.

This test report shall not be reproduce in part without written approval of HomeTek Technology Inc.

PREPARED BY : Ming yu Li DATE : 3/30/2004
MING YU LI

CHECK BY : Albert Tsai DATE : 3/30/2004
ALBERT TSAI / Senior Engineer

APPROVED BY : Tommy Rau DATE : 3/30/2004
TOMMY RAU / Manager



TABLE OF CONTENTS

GENERAL INFORMATION.....4

MODIFICATION LIST.....6

CONDUCTED POWER LINE TEST.....7

1 TEST INSTRUMENTS & FACILITIES7

2 TEST PROCEDURE.....7

3 TEST SETUP8

4 CONFIGURATION OF THE EUT.....10

5 EUT OPERATING CONDITION.....14

6 LIMIT OF CONDUCTED POWER LINE EMISSION :14

7 RESULT OF CONDUCTED POWER LINE TEST14

RADIATED EMISSION TEST 19

1 TEST PROCEDURE.....19

2 RESULT OF RADIATED EMISSION TEST19

DISTURBANCE VOLTAGE AT THE ANTENNA TERMINALS TEST..... 20

1 TEST PROCEDURE.....20

2 RESULT OF DISTURBANCE VOLTAGE AT THE ANTENNA TERMINALS TEST.....20

CLAMP EMISSION TEST..... 21

1 TEST INSTRUMENTS & FACILITIES21

2 TEST PROCEDURE.....22

3 TEST SETUP23

4 CONFIGURATION OF THE EUT.....24

5 EUT OPERATING CONDITION.....24

6 LIMIT OF CLAMP EMISSION TEST :24

7 RESULT OF CLAMP EMISSION TEST24

HARMONICS TEST..... 26

1 TEST INSTRUMENTS & FACILITIES26

2 TEST PROCEDURE.....26

3 TEST SETUP26

4 CONFIGURATION OF THE EUT.....26

5 OPERATION CONDITION OF EUT26

6 TEST DATA & LIMIT.....26

VOLTAGE FLUCTUATIONS TEST..... 29

1 TEST INSTRUMENTS & FACILITIES29

2 TEST PROCEDURE.....29

3 TEST SETUP29

4 CONFIGURATION OF THE EUT.....29

5 OPERATION CONDITION OF EUT29



6 TEST DATA & LIMIT29

ELECTROSTATIC DISCHARGE IMMUNITY TEST (ESD) 31

1 TEST INSTRUMENTS & FACILITIES31

2 TEST PROCEDURE.....31

3 TEST SETUP31

4 CONFIGURATION OF THE EUT.....32

5 EUT OPERATION CONDITION32

6 TEST CONDITION.....32

7 PERFORMANCE CRITERIA32

8 TEST RESULT33

RADIO FREQUENCY ELECTROMAGNETIC FIELD IMMUNITY TEST (RF) 34

1 TEST INSTRUMENTS & FACILITIES34

2 TEST PROCEDURE.....34

3 TEST SETUP35

4 CONFIGURATION OF THE EUT.....36

5 OPERATION CONDITION OF EUT36

6 TEST CONDITION.....36

7 PERFORMANCE CRITERIA36

8 TEST RESULT37

ELECTRICAL FAST TRANSIENT/BURST IMMUNITY TEST (EFT) 38

1 TEST INSTRUMENTS & FACILITIES38

2 TEST PROCEDURE.....38

3 TEST SETUP38

4 CONFIGURATION OF THE EUT.....39

5 OPERATION CONDITION OF EUT39

6 TEST CONDITION.....39

7 PERFORMANCE CRITERIA39

8 TEST RESULT40

SURGE IMMUNITY TEST..... 41

1 TEST INSTRUMENTS & FACILITIES41

2 TEST PROCEDURE.....41

3 TEST SETUP41

4 TEST LEVELS42

5 CONFIGURATION OF THE EUT.....42

6 EUT OPERATION CONDITION42

7 CONDITIONS DURING TESTING.....42

8 PERFORMANCE CRITERIA43

9 TEST RESULT43

IMMUNITY TEST TO RF CONDUCTED DISTURBANCE..... 44



1	TEST INSTRUMENTS & FACILITIES	44
2	TEST PROCEDURE.....	44
3	TEST SETUP	45
4	TEST LEVELS	46
5	CONFIGURATION OF THE EUT.....	46
6	EUT OPERATION CONDITION	46
7	CONDITIONS DURING TESTING.....	46
8	PERFORMANCE CRITERIA	47
9	TEST RESULT	47
POWER FREQUENCY MAGNETIC FIELD IMMUNITY TEST.....		48
1	TEST INSTRUMENTS & FACILITIES	48
2	TEST STANDARD.....	48
3	TEST SETUP	48
4	TEST LEVELS	49
5	CONFIGURATION OF THE EUT.....	49
6	OPERATION CONDITION OF EUT	49
7	CONDITIONS DURING TESTING.....	49
8	PERFORMANCE CRITERIA	49
9	TEST RESULTS	50
VOLTAGE DIPS, SHORT INTERRUPTIONS IMMUNITY TEST.....		51
1	TEST INSTRUMENTS & FACILITIES	51
2	TEST PROCEDURE.....	51
3	TEST SETUP	51
4	TEST LEVELS	52
5	CONFIGURATION OF THE EUT.....	52
6	EUT OPERATION CONDITION	52
7	CONDITIONS DURING TESTING.....	52
8	PERFORMANCE CRITERIA	52
9	TEST RESULT	53
APPENDIX A		
PHOTOS OF TEST CONFIGURATION		
APPENDIX B		
PHOTOS OF EUT		



GENERAL INFORMATION

- 1 APPLICANT : SMART CABLING & TRANSMISSION CORP.
- 2 ADDRESS : 3F., No. 4, Lane 130, Min-Chung Rd.,
Hsin-Tien City, Taipei Hsien, Taiwan, R. O. C.
- 3 MANUFACTURER : SMART CABLING & TRANSMISSION CORP.
- 4 ADDRESS : 3F., No. 4, Lane 130, Min-Chung Rd.,
Hsin-Tien City, Taipei Hsien, Taiwan, R. O. C.
- 5 DESCRIPTION OF EUT :
 - EUT : Video Distributor & Amplifier
 - Model : CD816XXX
 - Serial # : N/A
 - Data Cable : N/A

5.1 The difference between series of models CD816XXX is shown as below:

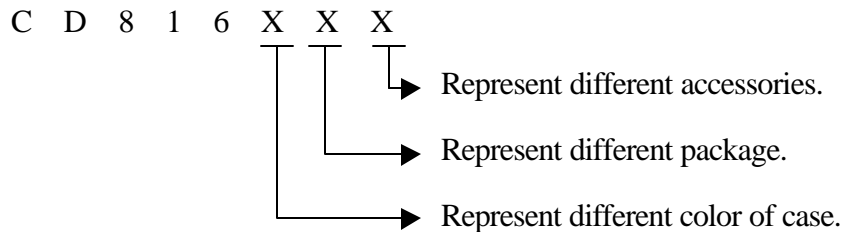

The worst case of EMC test model is CD816A and the final test data were shown in this test report.



6 FEATURES OF EUT :
Model No. CD816A

Video Input Channel	8
Video Output Channel	16
Video Input Level	0.8~1.2Vp-p, 75ohms
Video Bandwidth	10Hz ~ 10MHz
Power Supply	DC 12V
Power Consumption	500mA
Brightness	YES
Sharpness	YES
Dimensions (mm)	482x170x44 standard 1U Rack Panel
Weight	2.6kg
Material	Metal Black



MODIFICATION LIST

THE FOLLOWING ACCESSORIES WERE ADDED TO THE EUT DURING TESTING :

NO MODIFICATION BY HOMETEK TECHNOLOGY INC.



CONDUCTED POWER LINE TEST

1 TEST INSTRUMENTS & FACILITIES

The following test Instruments was used during the conducted test :

Item	Instruments/ Facilities	Specification	Manufacturer	Model #	Date Of Cal.
1	EMI Receiver	9KHz ~ 30MHz	ROHDE & SCHWARZ	ESHS 30 844827/007	MAR/2004
2	LISN (for EUT)	50 /50uH/100A 150KHz ~ 30MHz	SCHWARZ BECK	NNLK 8121 8121370	OCT/2003
3	LISN (for Support Unit)	50 /50uH/10A 9KHz ~ 30MHz	ROHDE & SCHWARZ	ESH3-Z5 846128/007	FEB/2004
4	Terminator	50	N/A	N/A	NOV/2003
5	Attenuation	50 /10dB	Mini-Circuit	NAT-10 AT-002	JUL/2003
6	Cable	3m	SUHNER	RG-223 CON2-001	DEC/2003
7	ESXS-K1 (software)	Version 2.03b 9KHz ~ 30MHz	ROHDE & SCHWARZ	1082.9678.02 840.913/246	N/A

Note : Items 1 ~ 6 were calibrated within period of 1 year.

2 TEST PROCEDURE

- 2.1 The EUT was tested according to **EN 55013**.
- 2.2 The EUT was placed 0.4 meter from the conducting wall of shielding room and kept at least 0.8 meter from any other grounded conducting surface.
- 2.3 The frequency range form 0.15 MHz to 30 MHz was investigated.
- 2.4 The LISN used was 50 Ohm / 50 uHenry as specified by **EN 55013**.
- 2.5 All the support peripherals are connect to the other LISN.
- 2.6 Cables and peripherals were moved to find the maximum emission levels for each frequency.

3 TEST SETUP

3.1 Typical : Setup Of Conducted Test

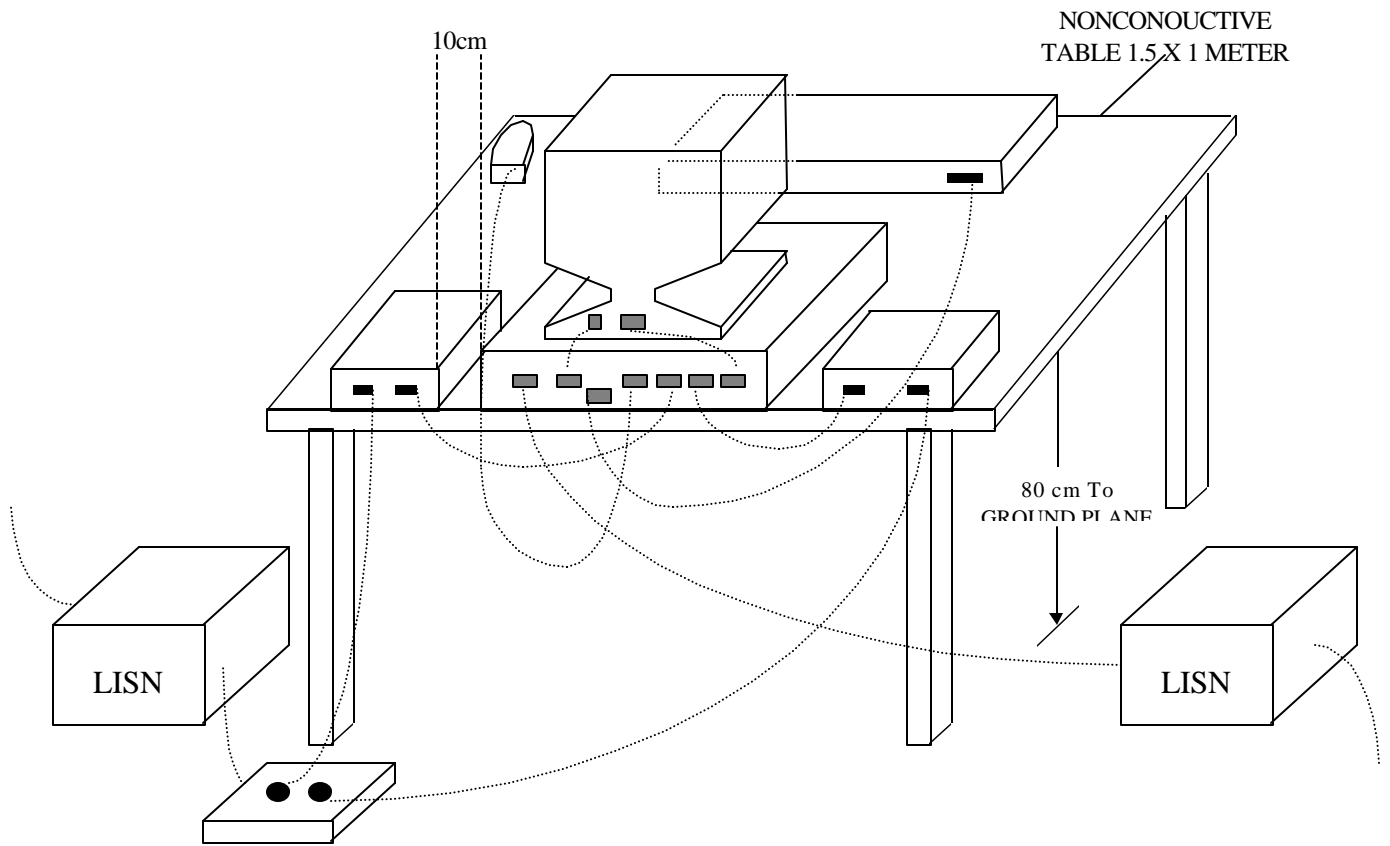

(Details for setup configuration, please refer to appendix A.)

3.2 Block Diagram Of Conducted Test

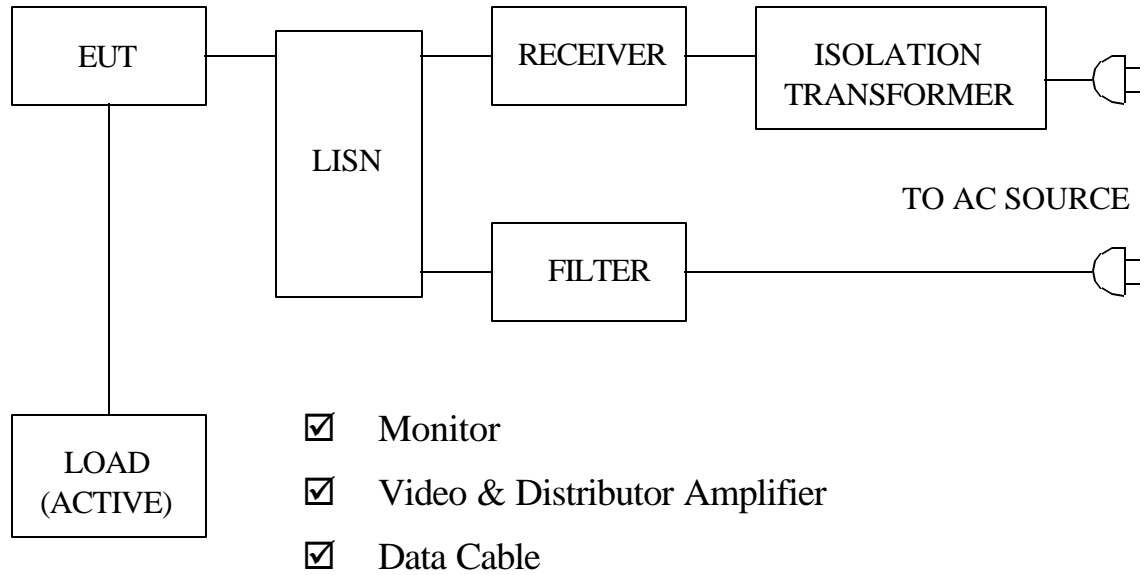

4 CONFIGURATION OF THE EUT

The EUT was configured according to **EN 55013**. All I/O ports were connected to the appropriate peripherals. All peripherals and cables are listed below (including internal device) :

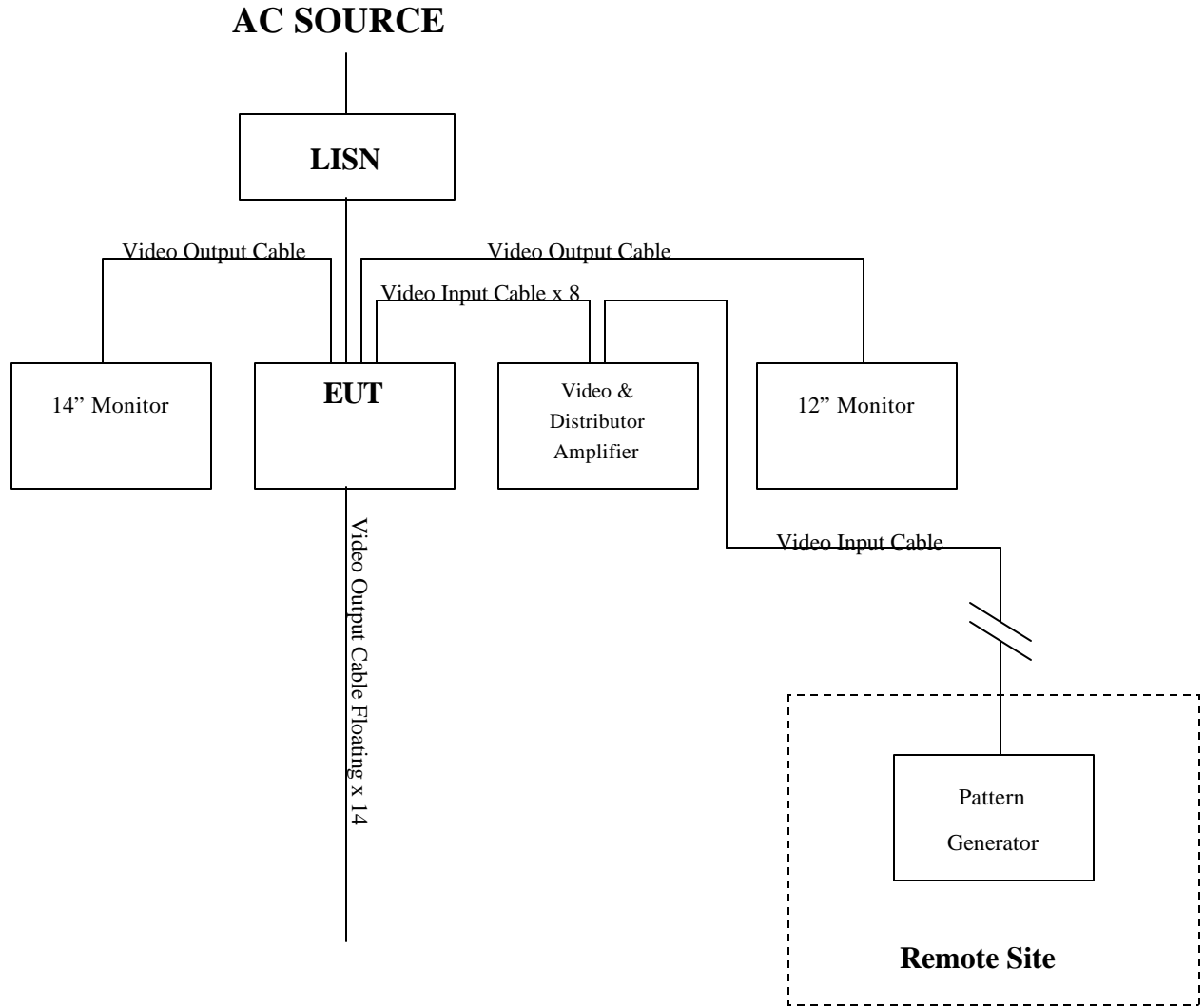

Figure 1



4.1 EUT

EUT Type : Proto Type Engineer Type Mass Production

Condition when received : Good Damage : _____

Device : Video Distributor & Amplifier

Applicant : SMART CABLING & TRANSMISSION CORP.

Manufacturer : SMART CABLING & TRANSMISSION CORP.

Model Number : CD816XXX

Serial Number : N/A

FCC ID : N/A

Data Cable1 (Video Input) : Shielded, 1.8 m, Metal Type

Data Cable2 (Video Input) : Shielded, 10 m, Metal Type

Data Cable3 (Video Output) : Shielded, 1.8 m, Metal Type

Power Cord (AC) Adapter : 2 pin

Power Cord (DC) Adapter : Un-Shielded, 1.9 m, 2 pin

Power Supply Type : Linear Adapter

4.2 PERIPHERALS

14" Monitor

Manufacturer : YOKO

Model Number : YK-8111

Serial Number : N/A

FCC ID : N/A

Data Cable : Shielded, 1.8 m

Power Cord : Un-Shielded, 1.8 m



12" Monitor

Manufacturer : YOKO
Model Number : YK-8102
Serial Number : N/A
FCC ID : N/A
Data Cable : Shielded, 1.8 m
Power Cord : Un-Shielded, 1.8 m

Video Distributor & Amplifier

Manufacturer : SMART CABLING
Model Number : CD108
Serial Number : N/A
FCC ID : N/A
Data Cable : Shielded, 1.8 m
Power Cord : Un-Shielded, 1.9 m

Power Adapter

Manufacturer : JELEC
Model Number : YAD-1200500E
Serial Number : N/A
FCC ID : N/A
Data Cable : N/A
Power Cord : Un-Shielded, 1.9 m



Pattern Generator (Remote Site)

Manufacturer	:	LEADER
Model Number	:	408
Serial Number	:	3037775
FCC ID	:	FCC DoC
Data Cable	:	Shielded
Power Cord	:	Un-Shielded, 1.8 m

4.3 REMARK : N/A



5 EUT OPERATING CONDITION

- 5.1 The operation frequency of the EUT is 10Hz ~ 10MHz.
- 5.2 Configure the EUT according to the **EN 55013**.
- 5.3 Turn on all the power of EUT and peripheral.
- 5.4 Remote pattern generator send 1KHz audio and color bar signal to EUT.
- 5.5 Monitor the output signal of EUT during the test. (For EMS testing)
- 5.6 The photos of conducted test configuration, please refer to appendix A.**

6 LIMIT OF CONDUCTED POWER LINE EMISSION :

Frequency Range	Quasi Peak	Average
0.15 ~ 0.5 MHz	66 - 56 dBuV	56 - 46 dBuV
0.5 ~ 5 MHz	56 dBuV	46 dBuV
5 ~ 30 MHz	60 dBuV	50 dBuV

7 RESULT OF CONDUCTED POWER LINE TEST

- 7.1 The frequency range from 0.15 MHz to 30 MHz was investigated. All readings are quasi-peak values and average.
- 7.2 IF bandwidth : 9 kHz, Meas Time : 1 sec.
- 7.3 Temperature : 27 , Humidity : 60 % RH.
- 7.4 Deviations from the test standards and rules : None
- 7.5 The conducted test result were gained by following procedures :
 Level = Reading Level + Insertion Loss of LISN + Cable Loss
 (All calculation were done by ESHS30 EMI test receiver.)
- 7.6 Result : **PASSED**



HomeTek EMC LAB. TEL :886-2-22608375

27 Mar 2004 17:18

CONDUCTED EMISSIONS

EUT: Video Distributor & Amplifier
Manuf: 3C030
Op Cond: LINE 1
Operator: ALBERT
Test Spec: FOR EN55013
Comment: 230V/50Hz
CD816A
Result File: 3c03011c.dat : CD816A

Prescan Measurement: Detectors X PK / + AV
Meas Time: see scan settings
Subranges: 18
Acc Margin: 55 dB

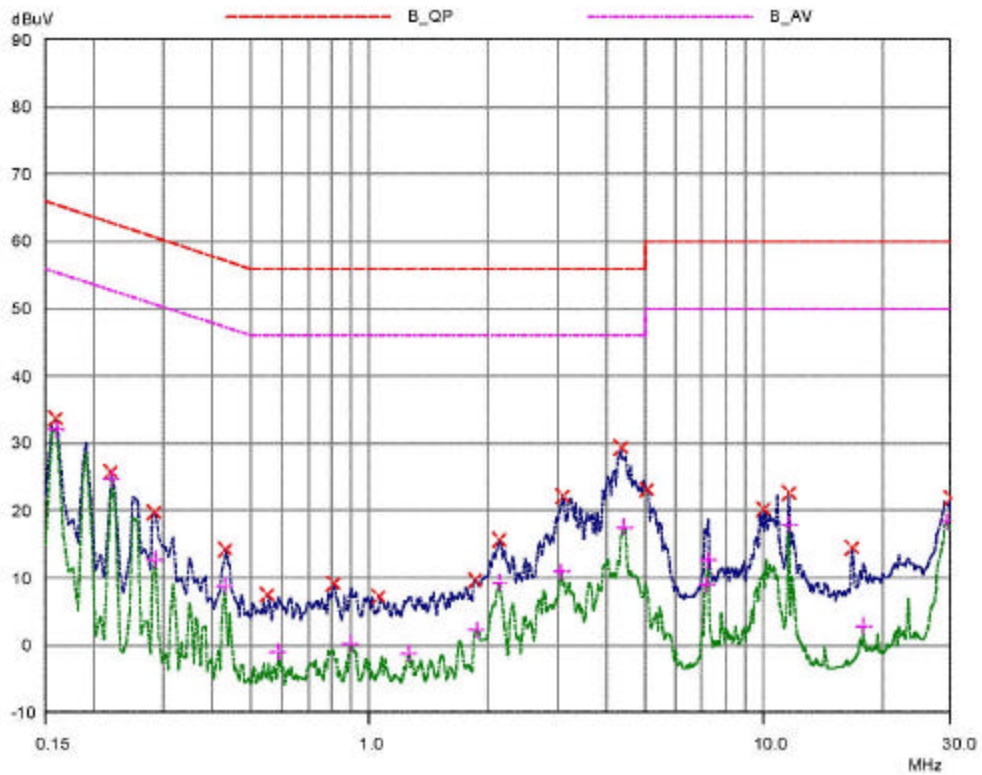



HomeTek EMC LAB. TEL :886-2-22608375

27 Mar 2004 17:18

CONDUCTED EMISSIONS

EUT: Video Distributor & Amplifier
 Manuf: 3C030
 Op Cond: LINE 1
 Operator: ALBERT
 Test Spec: FOR EN55013
 Comment: 230V/50Hz
 CD816A
 Result File: 3c03011c.dat : CD816A

Prescan Measurement: Detectors X PK / + AV
 Meas Time: see scan settings
 Subranges: 18
 Acc Margin: 55 dB

Peak Search Results

Frequency MHz	PK Level dBuV	PK Limit dBuV	PK Delta dB
0.16	33.68	65.46	31.78
0.22	25.84	62.82	36.98
0.285	19.71	60.67	40.96
0.43	14.29	57.25	42.96
0.55	7.81	56.00	48.39
0.81	9.13	56.00	46.87
1.055	7.21	56.00	48.79
1.855	9.87	56.00	46.33
2.125	15.68	56.00	40.32
3.085	22.15	56.00	33.85
4.345	29.36	56.00	26.64
5.04	23.16	60.00	36.84
10.01	20.19	60.00	39.81
11.64	22.61	60.00	37.39
18.84	14.44	60.00	45.56
29.99	21.83	60.00	38.17

Frequency MHz	AV Level dBuV	AV Limit dBuV	AV Delta dB
0.16	32.12	55.46	23.34
0.22	24.79	62.82	28.03
0.285	12.77	50.67	37.90
0.425	8.92	47.35	38.43
0.585	-0.97	46.00	46.97
0.895	0.24	46.00	45.76
1.28	-1.21	46.00	47.21
1.875	2.23	46.00	43.77
2.125	9.33	46.00	36.67
3.055	10.92	46.00	35.08
4.41	17.48	46.00	28.52
7.14	8.98	50.00	41.02
7.19	12.62	50.00	37.38
11.64	18.00	50.00	32.00
17.85	2.87	50.00	47.13
28.89	18.39	50.00	31.61

* limit exceeded



HomeTek EMC LAB. TEL :886-2-22608375

27 Mar 2004 17:11

CONDUCTED EMISSIONS

EUT: Video Distributor & Amplifier
Manuf: 3C030
Op Cond: LINE 2
Operator: ALBERT
Test Spec: FOR EN55013
Comment: 230V/50Hz
CD816A
Result File: 3c03021c.dat : CD816A

Prescan Measurement: Detectors X PK / + AV
Meas Time: see scan settings
Subranges: 18
Acc Margin: 55 dB

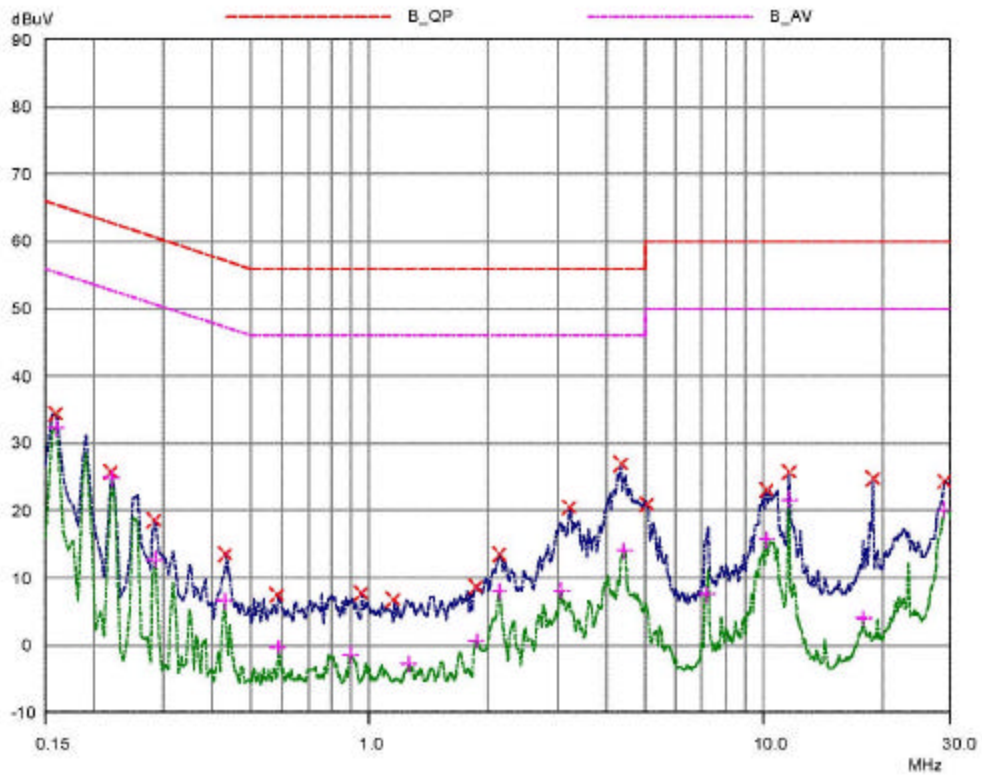



HomeTek EMC LAB. TEL :886-2-22608375

27 Mar 2004 17:11

CONDUCTED EMISSIONS

EUT: Video Distributor & Amplifier
 Manuf: 3C030
 Op Cond: LINE 2
 Operator: ALBERT
 Test Spec: FOR EN55013
 Comment: 230V/50Hz
 CD816A
 Result File: 3c03021c.dat : CD816A

Prescan Measurement: Detectors X PK / + AV
 Meas Time: see scan settings
 Subranges: 18
 Acc Margin: 55 dB

Peak Search Results

Frequency MHz	PK Level dBuV	PK Limit dBuV	PK Delta dB
0.16	34.36	65.46	31.10
0.22	25.86	62.82	36.96
0.285	18.45	60.67	42.22
0.43	13.55	57.25	43.70
0.585	7.53	56.00	48.47
0.955	7.83	56.00	48.17
1.155	6.71	56.00	49.29
1.86	8.76	56.00	47.24
2.125	13.60	56.00	42.40
3.21	20.37	56.00	35.63
4.345	26.86	56.00	29.14
5.04	21.00	60.00	39.00
10.14	23.04	60.00	36.96
11.64	25.78	60.00	34.22
19.0	24.92	60.00	35.08
28.62	24.42	60.00	35.58

Frequency MHz	AV Level dBuV	AV Limit dBuV	AV Delta dB
0.16	32.27	55.46	23.19
0.22	24.92	52.82	27.90
0.285	12.77	50.67	37.90
0.425	6.65	47.35	40.70
0.585	-0.32	46.00	46.32
0.895	-1.47	46.00	47.47
1.26	-2.81	46.00	48.81
1.875	0.65	46.00	45.35
2.125	8.01	46.00	37.99
3.055	8.19	46.00	37.81
4.41	14.09	46.00	31.91
7.14	7.52	50.00	42.48
10.14	15.75	50.00	34.25
11.64	21.67	50.00	28.33
17.87	4.01	50.00	45.99
28.7	20.20	50.00	29.80

* limit exceeded



RADIATED EMISSION TEST

1 TEST PROCEDURE

According to **EN 55013**.

2 RESULT OF RADIATED EMISSION TEST

N/A (This standard is not applicable to this EUT (Model : CD816A)).



DISTURBANCE VOLTAGE AT THE ANTENNA TERMINALS TEST

1 TEST PROCEDURE

According to **EN 55013**.

2 RESULT OF DISTURBANCE VOLTAGE AT THE ANTENNA TERMINALS TEST

N/A (This standard is not applicable to this EUT (Model : CD816A)).



CLAMP EMISSION TEST

1 TEST INSTRUMENTS & FACILITIES

The following test Instruments was used during the radiated emission test :

Item	Instruments /facilities	Specification	Manufacturer	Model # / S/N#	Location	Date of Cal.
1	Clamp Test Site	30MHz ~ 300MHz/6m	HomeTek	Clamp #1	Clamp Test Site	N/A
2	EMI TEST RECEIVER	30MHz ~ 1GHz	ROHDE & SCHWARZ	ESVS10 845165/017	Clamp Test Site	SEP/2003
3	RF SPECTRUM ANALYZER	N/A	HEWLETT PACKARD	8591E 3710A06158	Clamp Test Site	MAY/2003
4	PRE-AMPLIFIER	100KHz ~ 1.3GHz	HP	8447D 1937A03120	Clamp Test Site	MAR/2004
5	ABSORBING CLAMP	30MHz ~ 300MHz	ROHDE & SCHWARZ	MDS21 845061/004	Clamp Test Site	DEC/2003
6	EMI 32 (software)	N/A	AUDIX	19991013-0923		N/A

Note : Items 2 ~ 5 upon which need to calibrated are with period of 1 year.



2 TEST PROCEDURE

- 2.1 The EUT was test according to **EN 55013**.
- 2.2 The disturbance power test was performed at HomeTek Lab' s CLAMP Test Site .
- 2.3 The frequency range from 30 MHz to 300 MHz, the measurement were made with absorbing clamp.
- 2.4 The EUT were investigated with all signal cables individually as below:
 - Video Input toward EUT cable;
 - Video Input toward support unit cable;
 - Video output toward EUT cable;
 - Video output toward support unit cable;
 - AC power toward EUT cable;
 - DC power toward EUT cable;
 - DC power toward support unit cable

and the worst case of test data were shown in this test report.

3 TEST SETUP

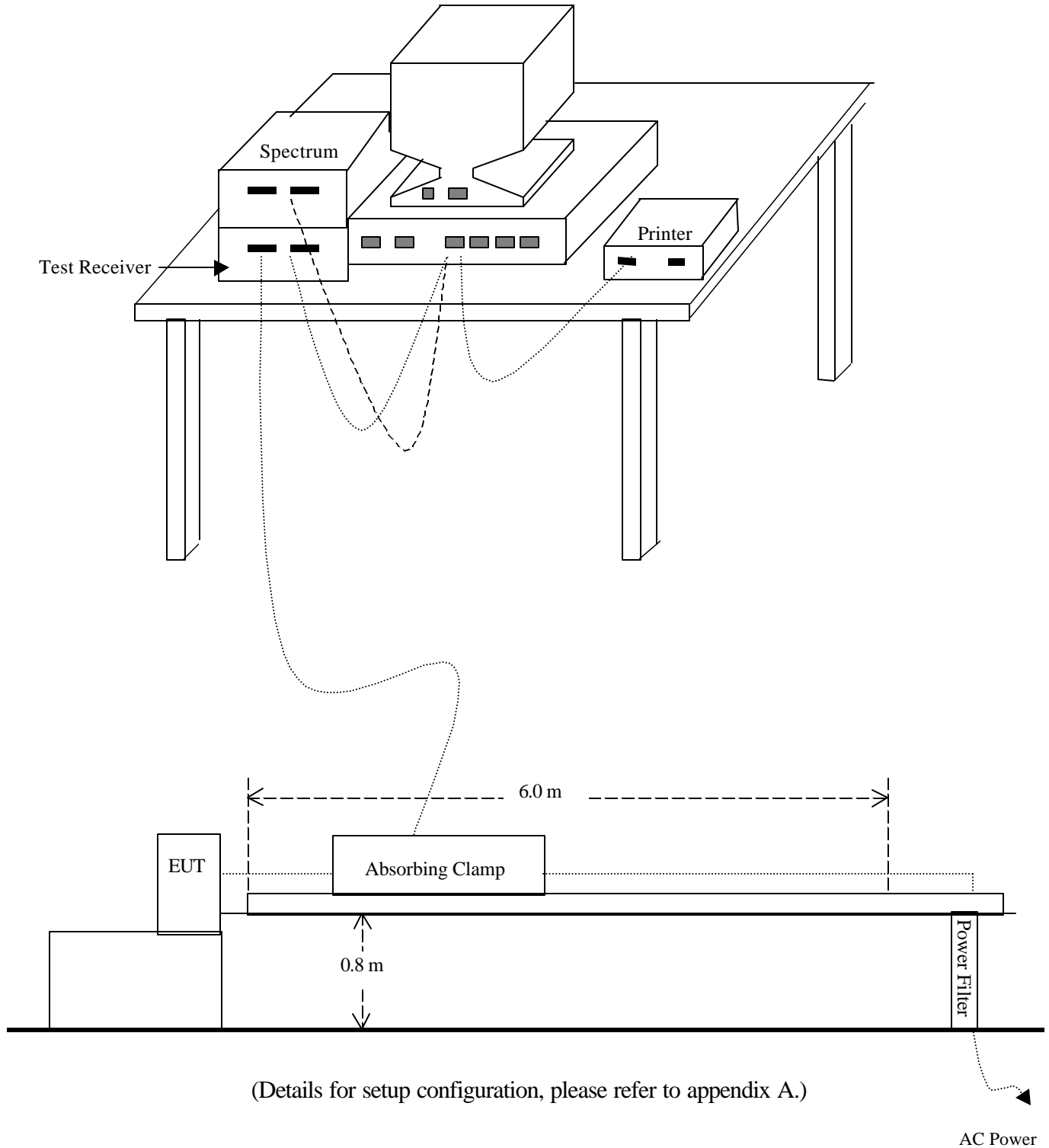



4 CONFIGURATION OF THE EUT

Same as “Conducted Power Line test”, section 4

5 EUT OPERATING CONDITION

5.1 Same as “Conducted Power Line test”, section 5

5.2 The photos of clamp emission test configuration, please refer to appendix A.

6 LIMIT OF CLAMP EMISSION TEST :

Frequency (MHz)	Limit Values (dBpW)	
	QP	AV
30 – 300	45 - 55	35 - 45
300 – 1000	N/A	N/A

7 RESULT OF CLAMP EMISSION TEST

7.1 The frequency range from 30 MHz to 300 MHz, the measurement were made with absorbing clamp.

7.2 The disturbance power test was performed at HomeTek Lab’ s CLAMP Test Site .

7.3 Temperature : 23 , Humidity : 55 % RH.

7.4 Test Mode : **Video Output toward EUT cable**

7.5 The clamp emission result were gained by the following method :

Level = Reading Level + Probe Factor (Antenna Factor) + Cable Loss – Preamp Factor
Over Limit = Level – Limit Line

7.6 The clamp mission test was passed at minimum margin :

30.00 MHz/ 34.22 dBuV/m, Antenna Height 5 Meter,
The Mode : Video Output toward EUT cable , Model : CD816A .

7.7 Result : **PASSED**



No 67-9, Shi-Men Rd., Tu-Chen City, Taipei County, Taiwan R.O.C
Tel: 02-22608375
Fax: 02-22748013

HomeTek Technology Inc.

Data#: 15 File#: 3c030.emi Date: 2004-03-29 Time: 17:53:24

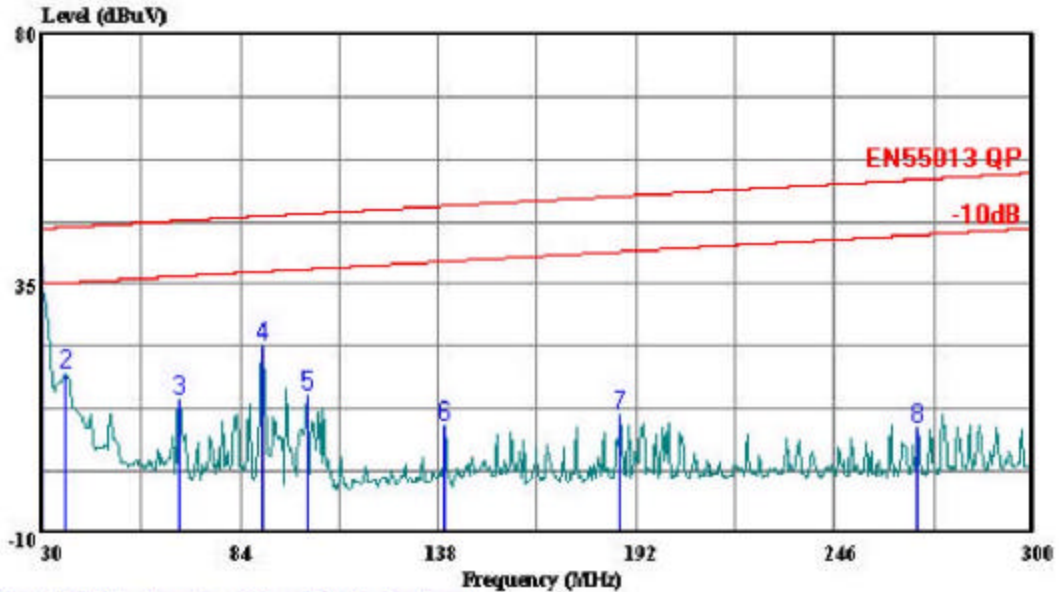

HomeTek Technology Inc. (HomeTek Technology)

Trace: 7

Ref Trace:

Condition: EN55013 QP MDS-21 120403
eut : Video Distributor & Amplifier
power: 230V/50Hz
memo : CD816A Video Output Toward EUT

Page:

	Freq	Level	Over Limit	Limit Line	Read Level	Probe Factor	Cable Loss	Preamp Factor	Remarks
	MHz	dBuV	dB	dBuV	dBuV	dB	dB	dB	
1	30.000	34.22	-10.78	45.00	58.30	2.40	1.42	27.90	Peak
2	36.480	18.92	-26.32	45.24	44.74	0.44	1.57	27.83	Peak
3	67.530	14.31	-32.08	46.39	41.32	-1.45	2.18	27.74	Peak
4	89.940	23.84	-23.38	47.22	50.81	-1.70	2.51	27.78	Peak
5	102.090	14.75	-32.92	47.67	41.73	-1.88	2.67	27.78	Peak
6	139.890	9.50	-39.57	49.07	35.92	-2.10	3.18	27.51	Peak
7	187.680	11.43	-39.41	50.84	36.72	-1.70	3.66	27.25	Peak
8	268.680	8.90	-44.94	53.84	33.40	-1.88	4.51	27.13	Peak

HARMONICS TEST

1 TEST INSTRUMENTS & FACILITIES

Instruments/ facilities	Manufacturer	Model # Serial #	Date of Cal.
HARMONICS/ VOLTAGE FLUCTUATIONS TEST	EMC-PARTNER	HAR1000-1P	OCT/2003
CONTROL PC	KB TECH	KB P586/133	N/A

2 TEST PROCEDURE

According to **EN 61000-3-2 (2000) Class A**

3 TEST SETUP

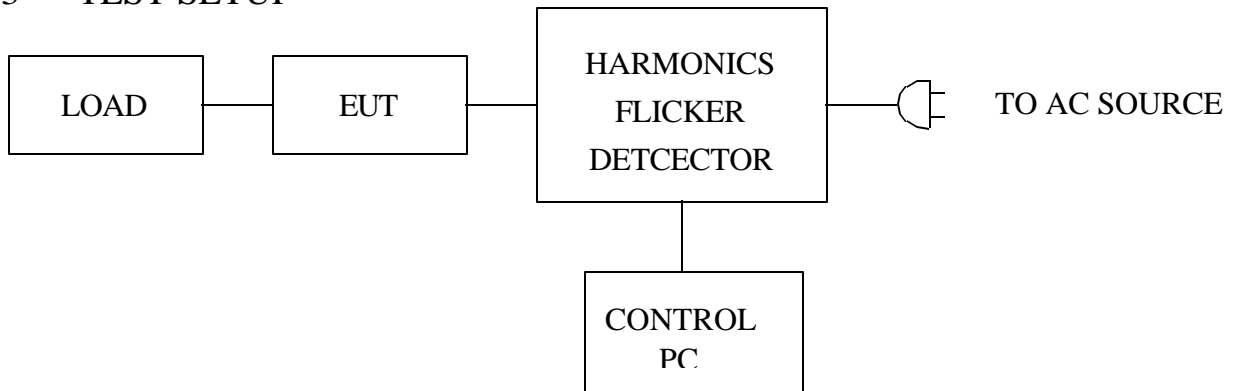

(Details for setup configuration, please refer to appendix A.)

4 CONFIGURATION OF THE EUT

Same as “Conducted Power Line test”, section 4

5 OPERATION CONDITION OF EUT

Same as “Conducted Power Line test”, section 5

6 TEST DATA & LIMIT

6.1 Temperature : 27

6.2 Humidity : 60 % RH

7 Photos of test configuration please refer to appendix A.



(3C030-H)

HOMETEK EMC LAB

Date : 2004/3/29 11:10:41 A V2.05

File :

Operator : TIM
 Unit : Video Distributor & Amplifier
 Serialnumber : CD816A
 Remarks : 3C030

Urms = 229.5V Freq = 50.000 Range: 0.25 A
 Irms = 0.031A Ipk = 0.061A cf = 1.922
 P = 4.129W Pap = 7.229VA pf = 0.571
 THDi = 43.7 % THDu = 0.10 % Class A

Test - Time : 15min (100 %)

Test completed, Result: PASSED

Order	Freq. [Hz]	I _{max} [A]	I _{max} % [%]	Limit [A]	Status
1	50	0.0284			
2	100	0.0003	0.0667	1.0800	
3	150	0.0096	2.0967	2.3000	
4	200	0.0002	0.0367	0.4300	
5	250	0.0100	2.1800	1.1400	
6	300	0.0001	0.0167	0.3000	
7	350	0.0006	0.1233	0.7700	
8	400	0.0000	0.0066	0.2300	
9	450	0.0008	0.1800	0.4000	
10	500	0.0000	0.0000	0.1840	
11	550	0.0009	0.2067	0.3300	
12	600	0.0000	0.0100	0.1533	
13	650	0.0005	0.2252	0.2100	
14	700	0.0000	0.0000	0.1314	
15	750	0.0003	0.2238	0.1500	
16	800	0.0000	0.0000	0.1150	
17	850	0.0003	0.2190	0.1324	
18	900	0.0000	0.0000	0.1022	
19	950	0.0002	0.1417	0.1184	
20	1000	0.0000	0.0000	0.0920	
21	1050	0.0001	0.1282	0.1071	
22	1100	0.0000	0.0000	0.0836	
23	1150	0.0001	0.1404	0.0978	
24	1200	0.0000	0.0000	0.0767	
25	1250	0.0001	0.1017	0.0900	
26	1300	0.0000	0.0000	0.0708	



(3C030-H)

27	1350	0.0001	0.1099	0.0833
28	1400	0.0000	0.0000	0.0657
29	1450	0.0001	0.0983	0.0776
30	1500	0.0000	0.0000	0.0613
31	1550	0.0001	0.0841	0.0726
32	1600	0.0000	0.0000	0.0575
33	1650	0.0001	0.0895	0.0682
34	1700	0.0000	0.0000	0.0541
35	1750	0.0000	0.0712	0.0643
36	1800	0.0000	0.0000	0.0511
37	1850	0.0000	0.0753	0.0608
38	1900	0.0000	0.0000	0.0484
39	1950	0.0000	0.0793	0.0577
40	2000	0.0000	0.0000	0.0460

VOLTAGE FLUCTUATIONS TEST

1 TEST INSTRUMENTS & FACILITIES

Instruments/ facilities	Manufacturer	Model # Serial #	Date of Cal.
HARMONICS/ VOLTAGE FLUCTUATIONS TEST	EMC-PARTNER	HAR1000-1P	OCT/2003
CONTROL PC	KB TECH	KB P586/133	N/A

2 TEST PROCEDURE

According to **EN 61000-3-3 (1995) + A1 (2001)**

3 TEST SETUP

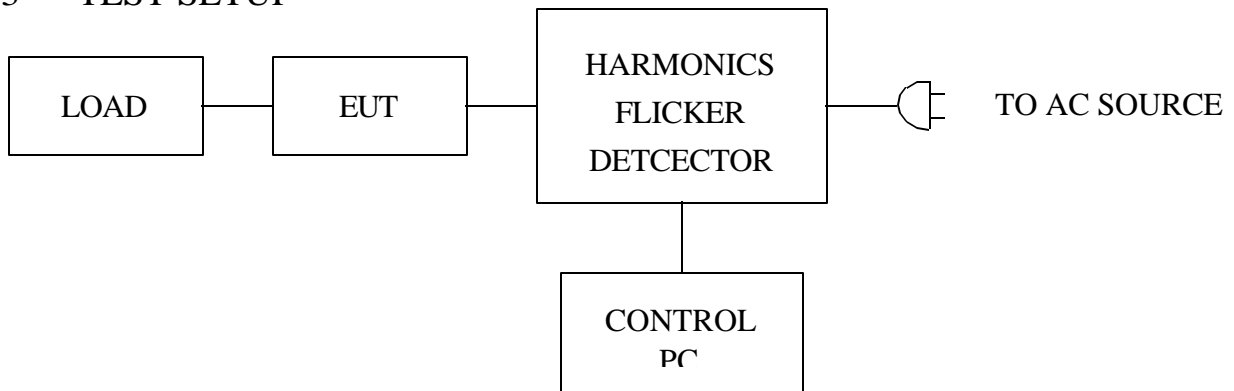

(Details for setup configuration, please refer to appendix A.)

4 CONFIGURATION OF THE EUT

Same as “Conducted Power Line test”, section 4

5 OPERATION CONDITION OF EUT

Same as “Conducted Power Line test”, section 5

6 TEST DATA & LIMIT

6.1 Temperature : 27

6.2 Humidity : 60 % RH

7 Photos of test configuration please refer to appendix A.



(3C030-F)

HOMETEK EMC LAB

Date : 2004/3/29 12:50:39 A V2.05

File :

Operator : TIM
 Unit : Video Distributor & Amplifier
 Serialnumber : CD816A
 Remarks : 3C030

Urms = 229.5V Freq = 50.000 Range: 0.25 A
 Irms = 0.031A Ipk = 0.061A cf = 1.922
 P = 4.123W Pap = 7.229VA pf = 0.570

Test - Time : 1 x 15min = 15min (100 %)

LIN (Line Impedance Network) : Soft LIN 0.24 Ohm +j 0.15 Ohm N: 0.16 Ohm +j 0.10 Ohm

Limits : Plt : 0.65 Pst : 1.00
 dmax : 4.00 % dc : 3.00 %
 dtLim: 3.00 % dt>Lim: 200ms

Test completed, Result: PASSED

Plt = 0.072

	Pst	dmax [%]
1	0.072	0.000

ELECTROSTATIC DISCHARGE IMMUNITY TEST (ESD)

1 TEST INSTRUMENTS & FACILITIES

Instruments/ Facilities	Manufacturer	Model # Serial #	Data Of Cal.
ESD TESTER	NOISEKEN	ESS-100L (A)	OCT/2003
VCP	HOMETEK	--	--

2 TEST PROCEDURE

According to **IEC 1000-4-2 (1995)**

According to **EN 61000-6-1 (2001)**

3 TEST SETUP

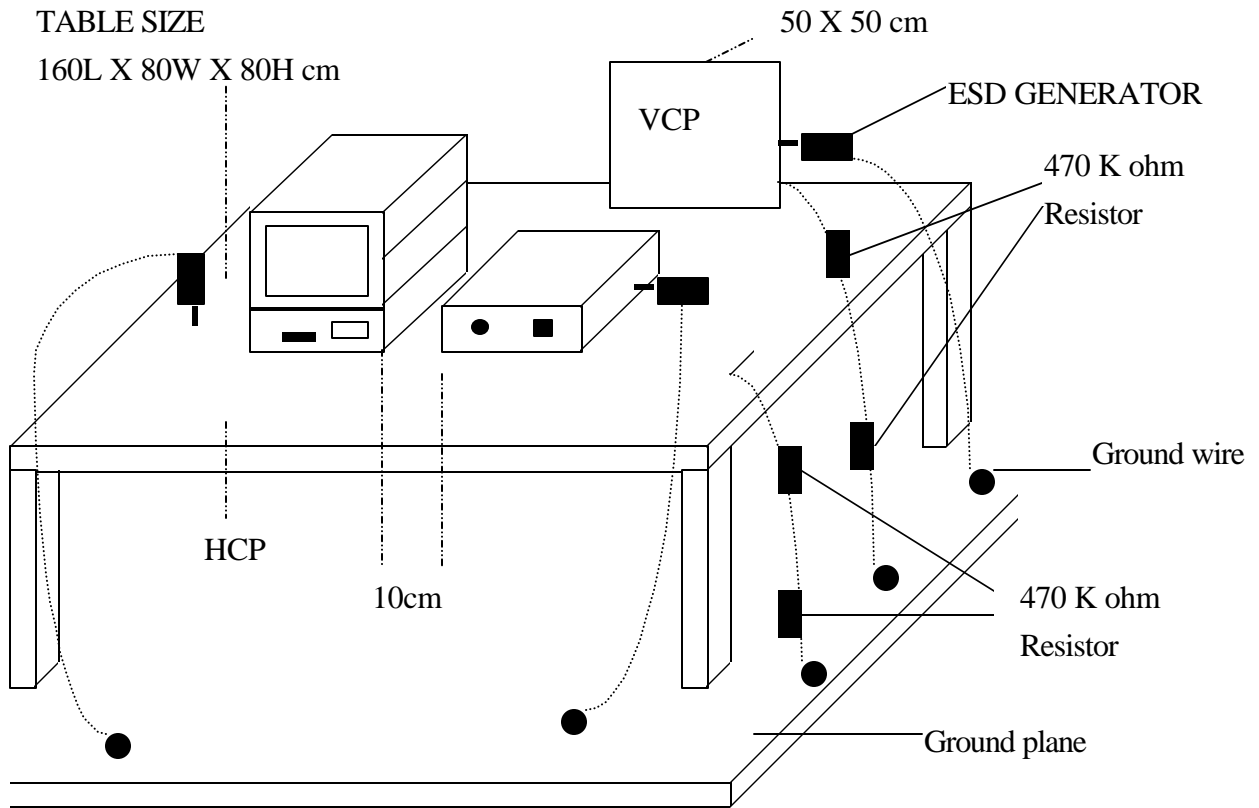

(Details for setup configuration, please refer to appendix A.)



4 CONFIGURATION OF THE EUT

Same as “Conducted Power Line test”, section 4

5 EUT OPERATION CONDITION

Same as “Conducted Power Line test”, section 5

6 TEST CONDITION

6.1 Test Level :

(A) $\pm 2, 4, 8$ KV for air discharge.

(B) $\pm 2, 4$ KV for contact discharge.

6.2 Number of test : 10 Discharges / Level

6.3 Time between test : 1 sec.

6.4 Temperature : 25

6.5 Humidity : 50 % RH.

7 PERFORMANCE CRITERIA

A. Normal performance within the specification.

B. Temporary degradation or loss function or performance which is self-recoverable.

C. Temporary degradation or loss function or performance which requires operator intervention system reset.

D. Degradation or loss function which is not recoverable due to damage of EUT or software, or loss of data.



8 TEST RESULT

Test Point	Air Discharge	Contact Discharge	Performance Criteria	Result
HCP	± 2, 4, 8KV	± 2, 4KV	A	PASSED
VCP	± 2, 4, 8KV	± 2, 4KV	A	PASSED
CASE	± 2, 4, 8KV	± 2, 4KV	A	PASSED
I/O PORTS	± 2, 4, 8KV	± 2, 4KV	A	PASSED
SCREWS	± 2, 4, 8KV	± 2, 4KV	A	PASSED
DC SOCKET	± 2, 4, 8KV	± 2, 4KV	A	PASSED
BUTTON	± 2, 4, 8KV	± 2, 4KV	A	PASSED

9 Photos of test configuration please refer to appendix A.



RADIO FREQUENCY ELECTROMAGNETIC FILE IMMUNITY TEST (RS)

1 TEST INSTRUMENTS & FACILITIES

Item	Instruments Facilities	Manufacturer	Model # Serial #	Data Of Cal.
1	SIGNAL GENERATOR	ROHDE & SCHWARZ	SMY02 845181/025	MAR/2004
2	AMPLIFIER	AMPLIFIER RESEARCH	100W1000M1A	N/A
3	FIELD SENSOR	AMPLIFIER RESEARCH	FP2000	AUG/2002
4	FIELD MONITOR	AMPLIFIER RESEARCH	FM2000	AUG/2002
5	RF VOLTMETER	BOONTON	9200C 361701AA	MAR/2004
6	RF PROBE	BOONTON	952001B 37082	MAR/2004
7	DIRECTION COUPLER	AMPLIFIER RESEARCH	DC6180 20521	N/A
8	ANTENNA	EMCO	3142B S/N: 1789	N/A
9	CONTROL PC	KB TECH	KB P586/133	--

Note : Items 3 ~ 4 were calibrated with two years and verified before testing.

2 TEST PROCEDURE

According to **IEC 61000-4-3 (1995)**

According to **EN 61000-6-1 (2001)**

3 TEST SETUP

FERRITE TILE

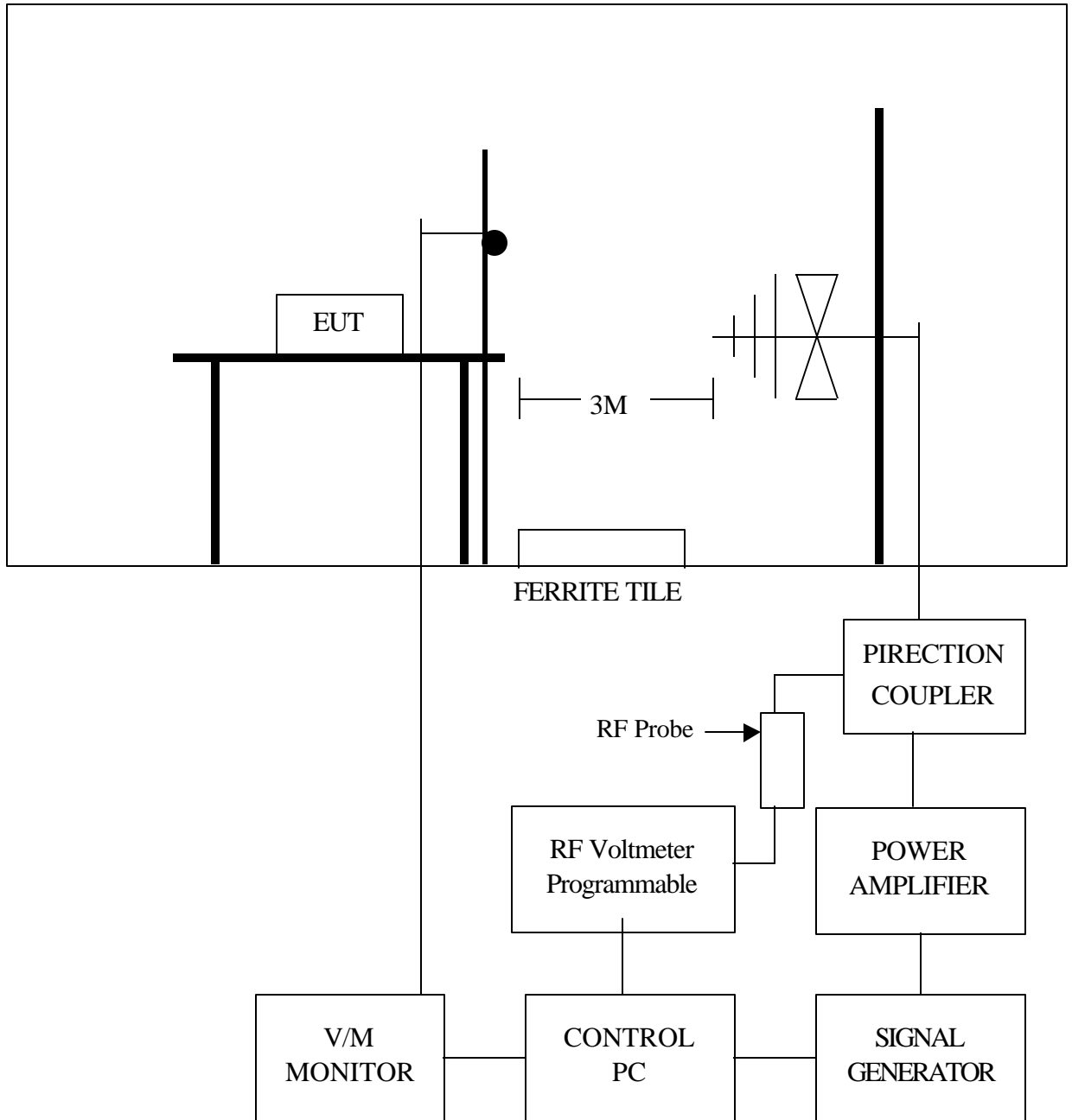

3.1 Chamber Size :

12M x 5M x 5M

(Details for setup configuration, please refer to appendix A.)



4 CONFIGURATION OF THE EUT

Same as “Conducted Power Line test”, section 4

5 OPERATION CONDITION OF EUT

Same as “Conducted Power Line test”, section 5

6 TEST CONDITION

6.1 Frequency Range : 80 MHz ~ 1000 MHz

6.2 Field Strength : 3 V / M (1KHz 80% Modulation)

6.3 Frequency Step : 1 %

6.4 Antenna Polarity : HORIZONTAL & VERTICAL

6.5 The four sides of EUT are tested
(FRONT, REAR, RIGHT, LEFT)

6.6 Temperature : 20

6.7 Humidity : 72 % RH

7 PERFORMANCE CRITERIA

- A. Normal performance within the specification.
- B. Temporary degradation or loss function or performance which is self-recoverable.
- C. Temporary degradation or loss function or performance which requires operator intervention system reset.
- D. Degradation or loss function which is not recoverable due to damage of EUT or software, or loss of data.



8 TEST RESULT

ANT SIDE	HORIZONTAL	VERTICAL	RESULT
FRONT	A	A	PASSED
REAR	A	A	PASSED
RIGHT	A	A	PASSED
LEFT	A	A	PASSED

9 Photos of test configuration please refer to appendix A.

ELECTRICAL FAST TRANSIENT/BURST IMMUNITY TEST (EFT)

1 TEST INSTRUMENTS & FACILITIES

Instruments/ Facilities	Manufacturer	Model # Serial #	Data Of Cal.
BURST-TESTER	HAEFELY	PEFT/JUNIOR	FEB/2004
CONTROL PC	KB TECH	KB P586/133	--

2 TEST PROCEDURE

According to **IEC 61000-4-4 (1995)**

According to **EN 61000-6-1 (2001)**

3 TEST SETUP

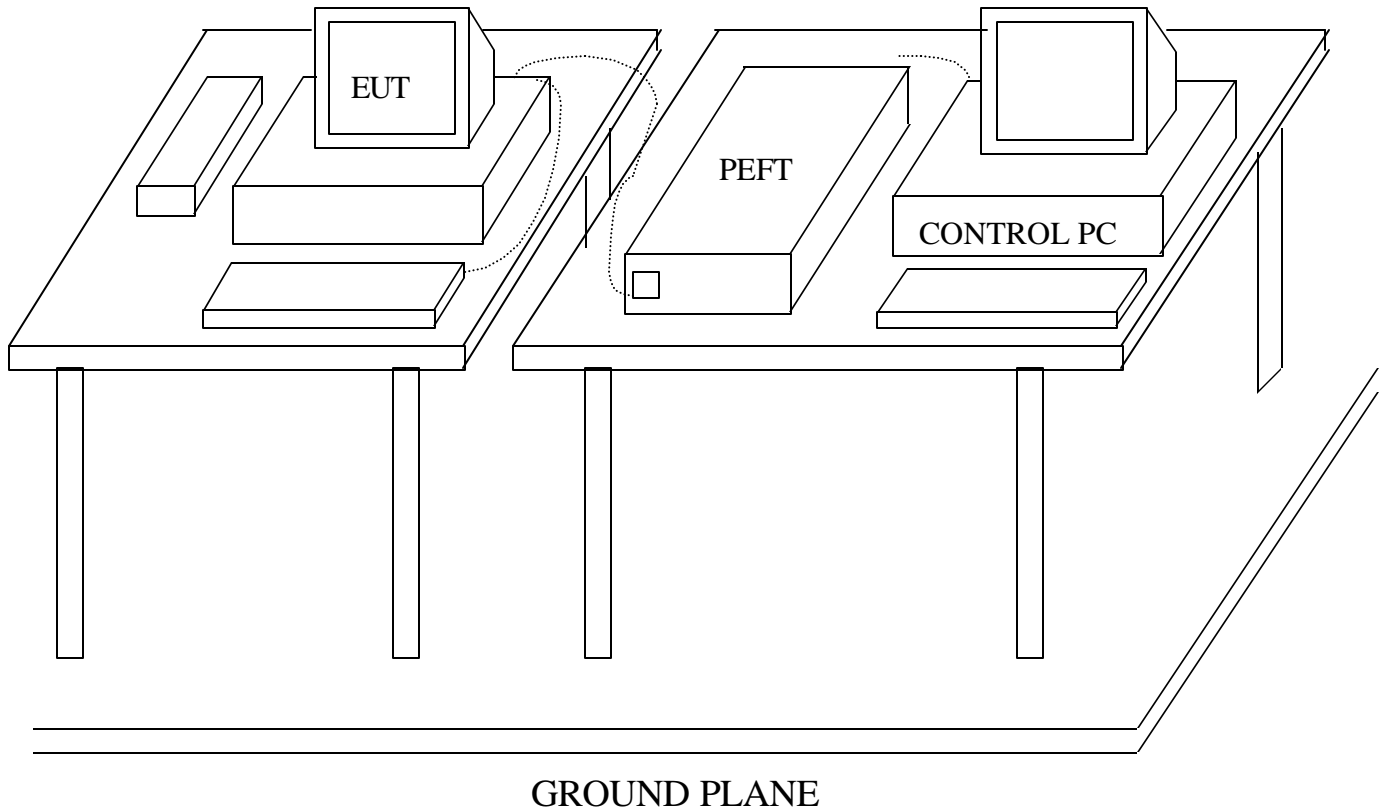

(Details for setup configuration, please refer to appendix A.)



4 CONFIGURATION OF THE EUT

Same as “Conducted Power Line test”, section 4

5 OPERATION CONDITION OF EUT

Same as “Conducted Power Line test”, section 5

6 TEST CONDITION

6.1 Pulse Rise time & Duration : 5 nS / 50 nS

6.2 Pulse Repetition : 5 kHz

6.3 Polarity : POSITIVE / NEGATIVE

6.4 Test Voltage of Power Line : $\pm 0.5KV$, $\pm 1KV$

6.5 Coupling of power line :
L, N, L+N

6.6 Test Voltage of Signal Control Line : $\pm 0.25KV$, $\pm 0.5KV$

6.7 Temperature : 27

6.8 Humidity : 60 % RH

7 PERFORMANCE CRITERIA

- A. Normal performance within the specification.
- B. Temporary degradation or loss function or performance which is self-recoverable.
- C. Temporary degradation or loss function or performance which requires operator intervention system reset.
- D. Degradation or loss function which is not recoverable due to damage of EUT or software, or loss of data.



8 TEST RESULT

Power Line :

TEST VOLTAGE	L	N	L+N
± 0.5KV	A	A	A
± 1KV	A	A	A

Signal Control Line :

TEST VOLTAGE	PERFORMACE CRITERIA
± 0.25KV	A
± 0.5KV	A

8.1 Model : CD816A

8.2 Final Result : PASSED

8.3 Remark :

9 Photos of test configuration please refer to appendix A.

SURGE IMMUNITY TEST

1 TEST INSTRUMENTS & FACILITIES

Instruments/ Facilities	Manufacturer	Model # Serial #	Data Of Cal.
SURGER-TESTER	HAEFELY	PSURGE 4010 583334-38	FEB/2004
CONTROL PC	KB TECH	KB P586/133	--

2 TEST PROCEDURE

According to **IEC 61000-4-5 (1995)**

According to **EN 61000-6-1 (2001)**

3 TEST SETUP

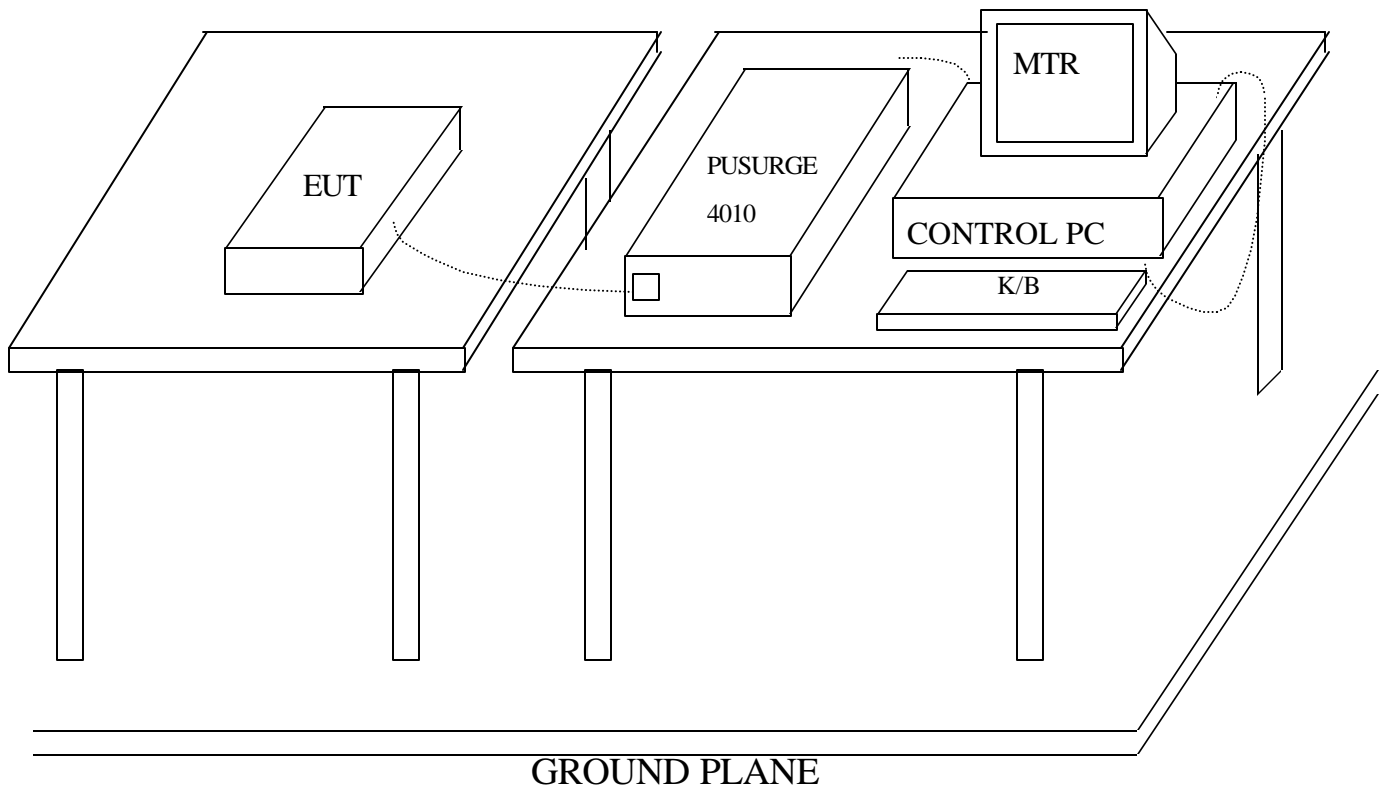

(Details for setup configuration, please refer to appendix A.)



4 TEST LEVELS

- Input and Output AC Power Ports.
- DC Input and DC Output Power Ports.

Environmental Phenomena	Test Specification		Units	Performance Criteria
	AC	DC		
Surges	1.2 / 50 (8/20)		Tr /Th us	
Line to Line	± 1	± 0.5	KV (Charge Voltage)	B

5 CONFIGURATION OF THE EUT

Same as “Conducted Power Line test”, section 4

6 EUT OPERATION CONDITION

Same as “Conducted Power Line test”, section 5

7 CONDITIONS DURING TESTING

7.1 Coupling of power line :

(A) Line to Line ± 1KV (AC) or ± 0.5KV (DC)

7.2 Polarity : POSITIVE / NEGATIVE

7.3 Phase shifting in a range between 0 ° to 360 °

7.4 Repetion rate at least 1 per min

7.5 Temperature : 22 (15 ~ 35)

Humidity : 70 % RH.(10 % ~ 75%)



8 PERFORMANCE CRITERIA

- A. Normal performance within the specification limits.
- B. Temporary degradation or loss of function or performance which is self-recoverable.
- C. Temporary degradation or loss of function or performance which requires operator intervention or system reset.
- D. Degradation or loss of function which is not recoverable due to damage of equipment (components).

9 TEST RESULT

Environmental Phenomena	Test Specification	Units	Performance
Line to Line	± 1	KV (Charge Voltage)	A

9.1 Model : CD816A

9.2 Final Result : PASSED

9.3 Remark :



IMMUNITY TEST TO RF CONDUCTED DISTURBANCE

1 TEST INSTRUMENTS & FACILITIES

Instruments/ Facilities	Manufacturer	Model # Serial #	Date Of Cal.
SIGNAL GENERATOR	ROHDE & SCHWARZ	SMY02 845181/025	MAR/2004
AMPLIFIER	AMPLIFIER RESEARCH	75A250 25680	N/A
RF VOLTMETER	BOONTON	9200C 361701AA	MAR/2004
RF PROBE	BOONTON	952001B 37082	MAR/2004
DIRECTION COUPLER	AMPLIFIER RESEARCH	DC2600 20508	N/A
COUPLING DECOUPLING NETWORK	FCC	FCC-801-M3-25A 9993	FEB/2004
CONTROL PC	KB TECH	KB P586/133	--

2 TEST PROCEDURE

According to **IEC 61000-4-6 (1996)**

According to **EN 61000-6-1 (2001)**

3 TEST SETUP

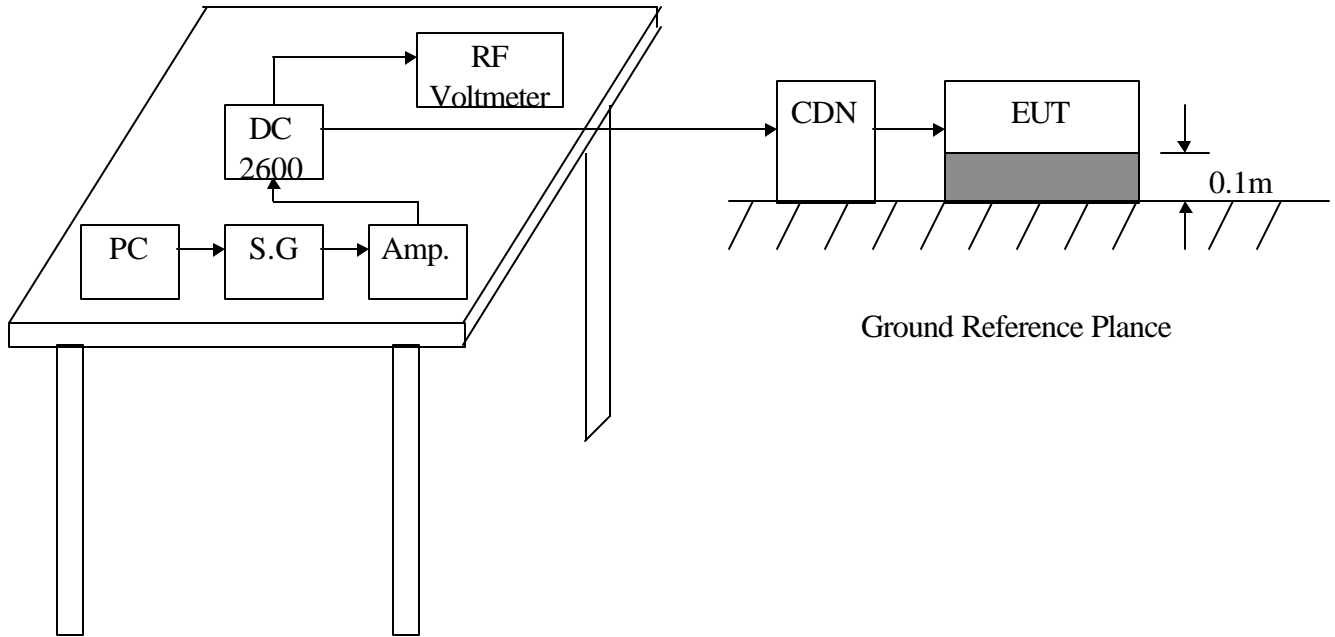

(Details for setup configuration, please refer to appendix A.)



4 TEST LEVELS

- Ports for signal lines and control lines.
- DC input and DC output power ports.
- Input and Output AC Power Ports.
- Functional earth Ports.

Environmental	Test Specification	Units	Performance
Radio-frequency	0.15 - 80	MHz	
Common mode	3	V	A
	80	% AM (1KHz)	

5 CONFIGURATION OF THE EUT

Same as “Conducted Power Line test”, section 4

6 EUT OPERATION CONDITION

Same as “Conducted Power Line test”, section 5

7 CONDITIONS DURING TESTING

7.1 The EUT tested type :

- Single unit
- Multiple unit

7.2 Dwell time : < 1%

7.3 Temperature : 24 (15 ~ 35)

Humidity : 72 % RH.(10 % ~ 75%)



8 PERFORMANCE CRITERIA

- A. Normal performance within the specification limits.
- B. Temporary degradation or loss of function or performance which is self-recoverable.
- C. Temporary degradation or loss of function or performance which requires operator intervention or system reset.
- D. Degradation or loss of function which is not recoverable due to damage of equipment (components).

9 TEST RESULT

TEST Specification	Unit	Performance Criteria
0.15 - 80	MHz	A
3	V	
80	% AM (1KHz)	

9.1 Model : CD816A

9.2 Final Result : PASSED

9.3 Remark :

POWER FREQUENCY MAGNETIC FIELD IMMUNITY TEST

1 TEST INSTRUMENTS & FACILITIES

Instruments/ Facilities	Manufacturer	Model # Serial #	Data Of Cal.
LINE INTERFERENCE TESTER	HAEFELY	PLINE 1610 080166-10	MAR/2004
MAGNETIC FIELD TESTER	HAEFELY	MAG 100.1 080206-01	N/A
TRIAXIAL ELF MAGNETIC FIELD METER	F.W.BELL	4080 9645	MAY/2003
CONTROL PC	KB TECH	KB P586/133	--

2 TEST STANDARD

According to **IEC 61000-4-8 (1993)**

According to **EN 61000-6-1 (2001)**

3 TEST SETUP

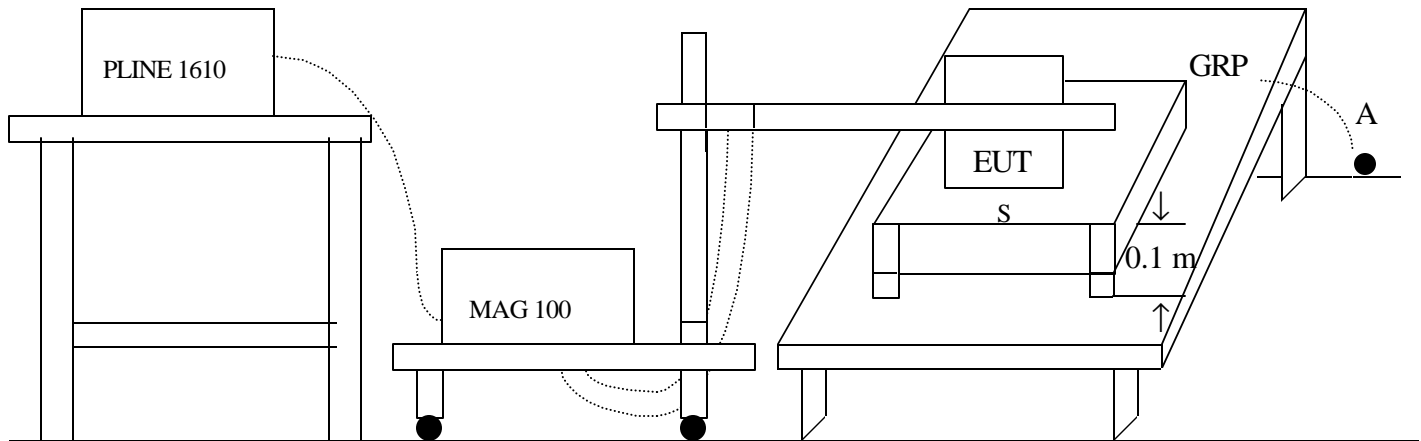

S: Insulating support

A: Safety earth

GRP: Ground plane

(Details for setup configuration, please refer to appendix A.)



4 TEST LEVELS

Environmental Phenomena	Test Specification	Units	Performance Criteria
Power Frequency	50	HZ	
Magnetic Field	3	A/m	A

5 CONFIGURATION OF THE EUT

Same as “Conducted Power Line test”, section 4

6 OPERATION CONDITION OF EUT

Same as “Conducted Power Line test”, section 5

7 CONDITIONS DURING TESTING

7.1 Temperature : 21 (15 ~ 35)

Humidity : 72 % RH.(25 % ~ 75%)

7.2 The induction coil shall be rotated by 90 °

8 PERFORMANCE CRITERIA

- A. Normal performance within the specification limits.
- B. Temporary degradation or loss of function or performance which is self-recoverable.
- C. Temporary degradation or loss of function or performance which requires operator intervention or system reset.
- D. Degradation or loss of function which is not recoverable due to damage of equipment (components).



9 TEST RESULTS

Environmental Phenomena	Test Specification	Units	Performance Criteria
Magnetic Field	3	A/m	A

9.1 Model : CD816A

9.2 Final Results : PASSED

9.3 Remark :

VOLTAGE DIPS, SHORT INTERRUPTIONS IMMUNITY TEST

1 TEST INSTRUMENTS & FACILITIES

Instruments/ Facilities	Manufacturer	Model # Serial #	Data Of Cal.
LINE INTERFERENCE -TESTER	HAEFELY	PLINE 1610 080166-10	MAR/2004
CONTROL PC	KB TECH	KB P586/133	--

2 TEST PROCEDURE

According to **IEC 61000-4-11 (1994)**

According to **EN 61000-6-1 (2001)**

3 TEST SETUP

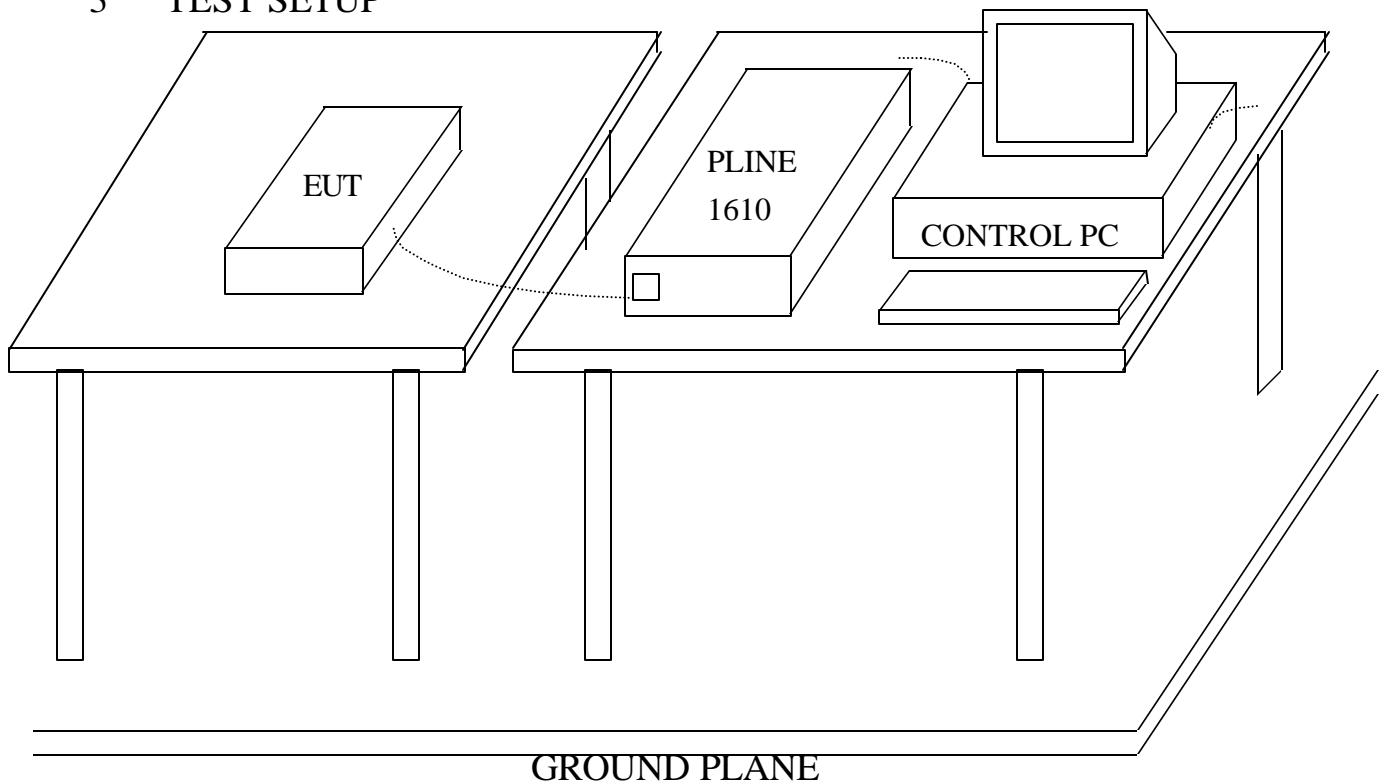



4 TEST LEVELS

Input and Output AC Power Ports.

- Voltage Dips.
- Voltage Interruptions.

Environmental Phenomena	Test Specification	Units	Perform Criteria
Voltage Dips	30	% Reduction	B
	10	ms	
	60	% Reduction	C
100	ms		
Voltage Interruptions	> 95 % 5000	% Reduction ms	C

5 CONFIGURATION OF THE EUT

Same as “Conducted Power Line test”, section 4

6 EUT OPERATION CONDITION

Same as “Conducted Power Line test”, section 5

7 CONDITIONS DURING TESTING

7.1 Temperature : 24 (15 ~ 35)

Humidity : 72 % RH.(25 % ~ 75%)

8 PERFORMANCE CRITERIA

- A. Normal performance within the specification limits.
- B. Temporary degradation or loss of function or performance which is self-recoverable.
- C. Temporary degradation or loss of function or performance which requires operator intervention or system reset.
- D. Degradation or loss of function which is not recoverable due to damage of equipment (components).



9 TEST RESULT

Environmental Phenomena	Test Specification	Units	Perform Criteria
Voltage Dips	30	% Reduction	A
	10	ms	
	60	% Reduction	C
100	ms		
Voltage Interruptions	> 95 %	% Reduction	C
	5000	ms	

9.1 Model : CD816A

9.2 Final Results : PASSED

9.3 Remark :



HomeTek Technology Inc.

Appendix A
PHOTOS OF TEST CONFIGURATION

PHOTO OF CONDUCTED POWER LINE TEST

Model: CD816A



Front View

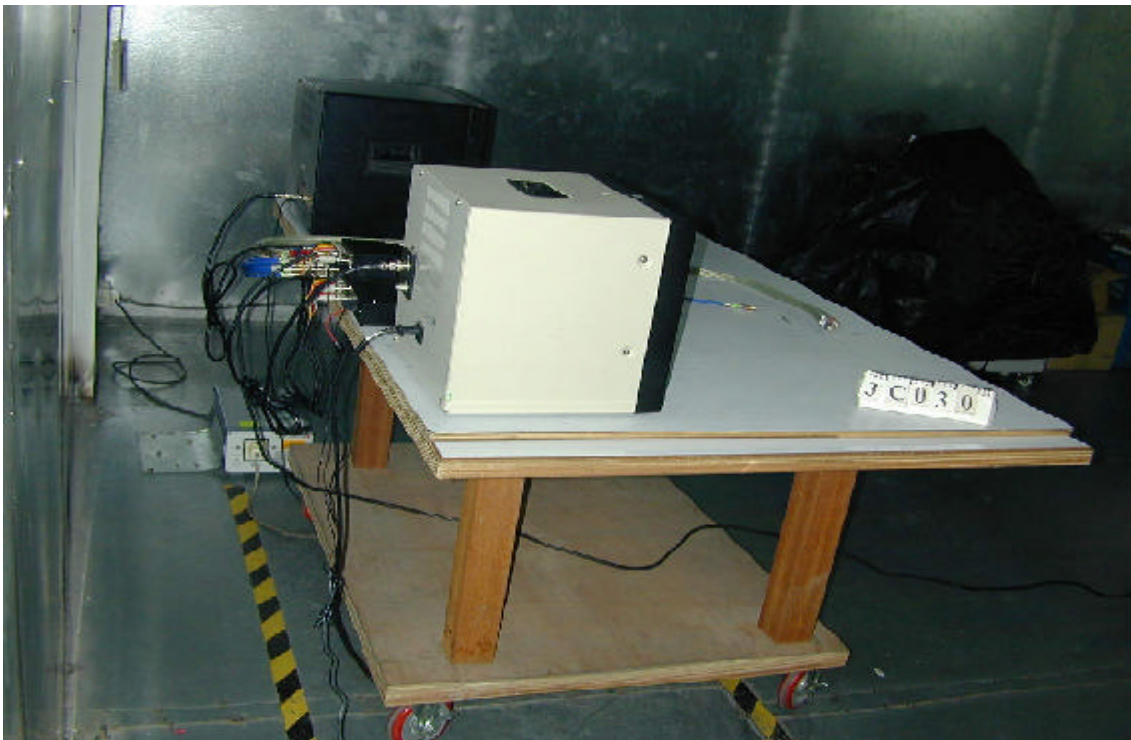

Rear View

PHOTO OF CLAMP EMISSION TEST

Test Mode : VIDEO OUTPUT , Model : CD816A

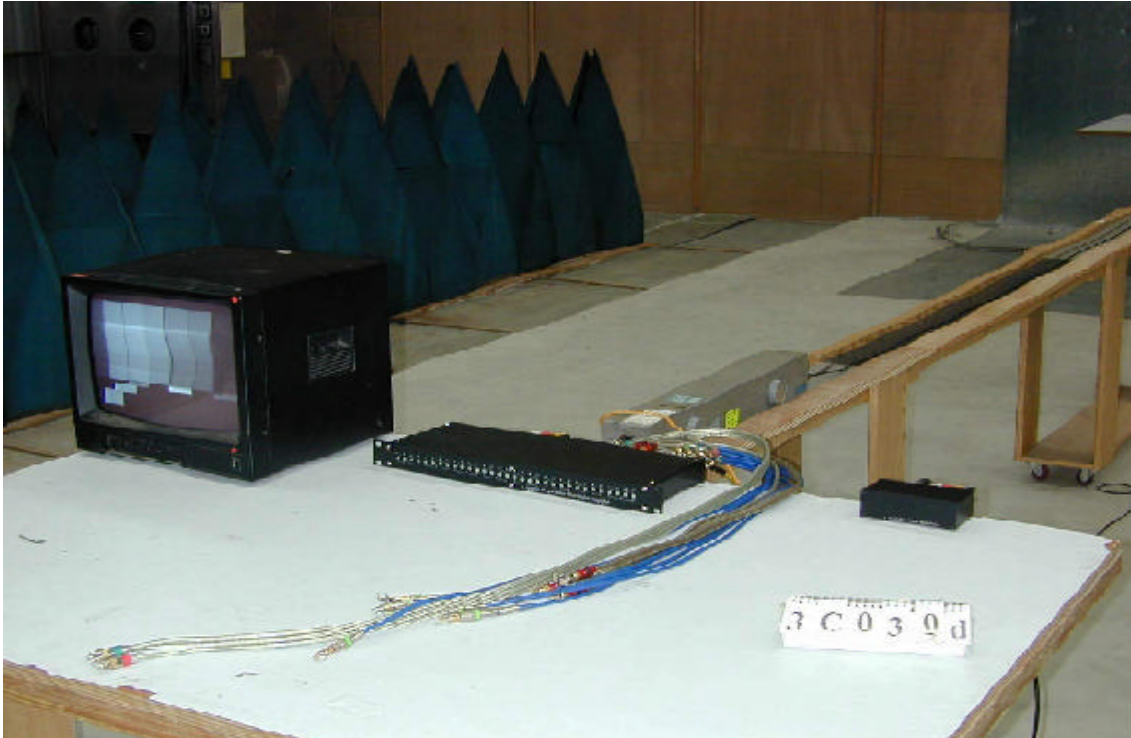

Front View



Rear View

**PHOTO OF HARMONICS & VOLTAGE FLUCTUATIONS TEST
AND SURGE IMMUNITY TEST AND ELECTRICAL FAST TRAN-
SIENT/BURST IMMUNITY TEST AND VOLTAGE DIPS, SHORT
INTERRUPTIONS IMMUNITY TEST**

Model : CD816A



Front View

**PHOTO OF ELECTROSTATIC DISCHARGE IMMUNITY TEST
(ESD)**

Model: CD816A



**PHOTO OF POWER FREQUENCY MAGNETIC FIELD
IMMUNITY TEST**



**PHOTO OF RADIO FREQUENCY ELECTROMAGNETIC FILE
IMMUNITY TEST (RS)**

Model: CD816A

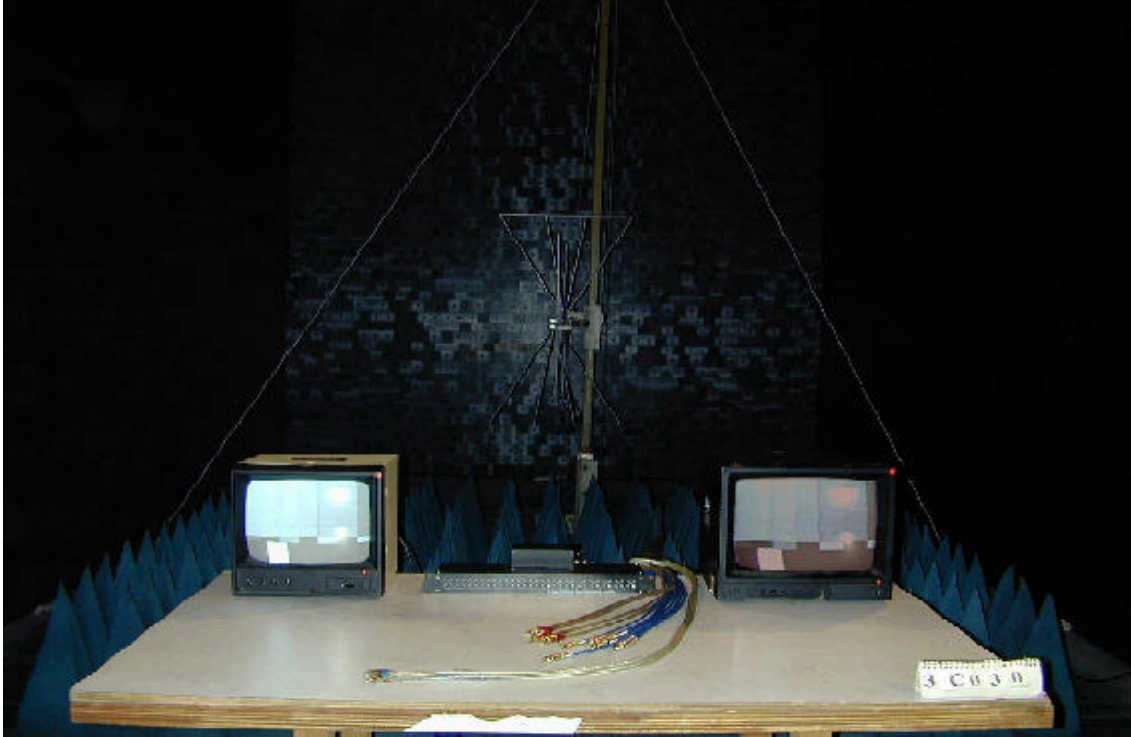
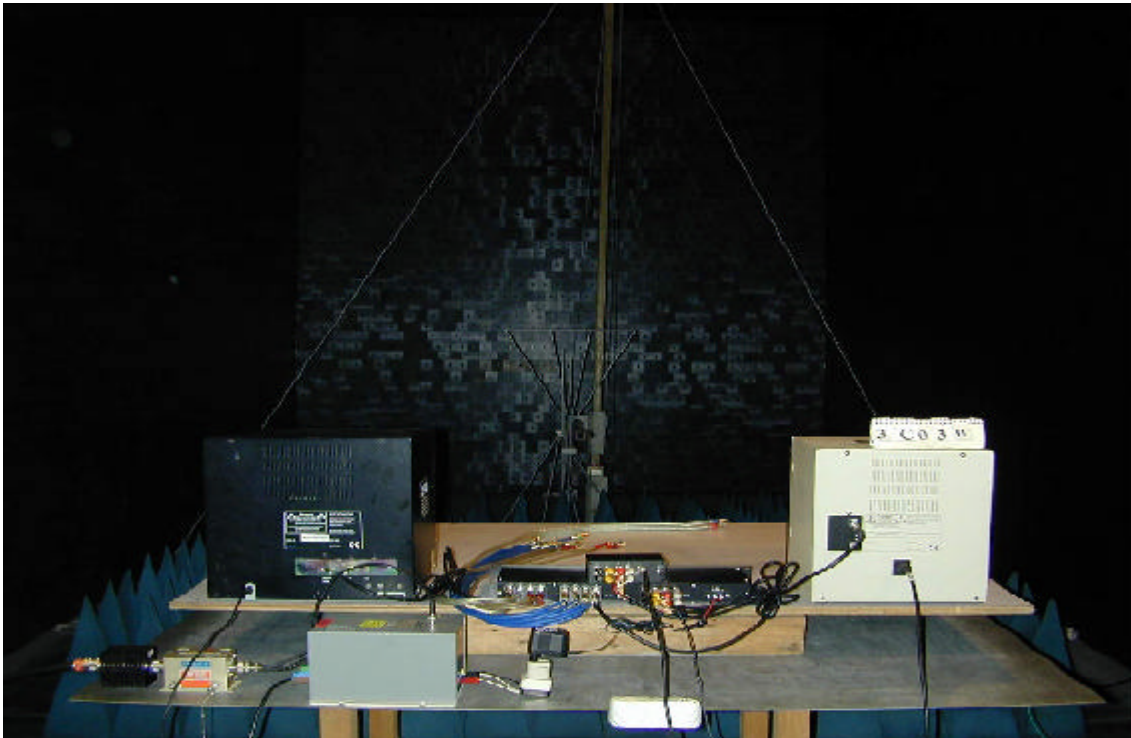

PHOTO OF CS CONDUCTED DISTURBANCE IMMUNITY TEST





HomeTek Technology Inc.

Appendix B

PHOTOS OF EUT

PHOTO OF EUT

Model : CD816A



Full View of EUT

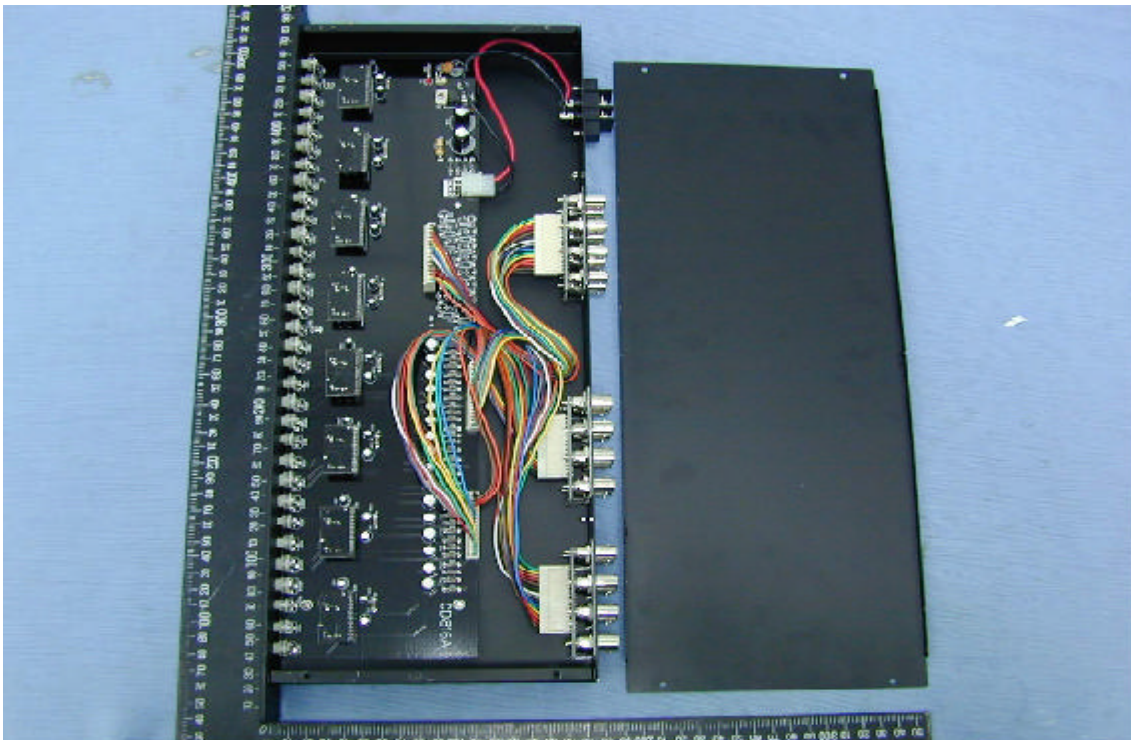

Inside View of EUT

PHOTO OF EUT

Model : CD816A

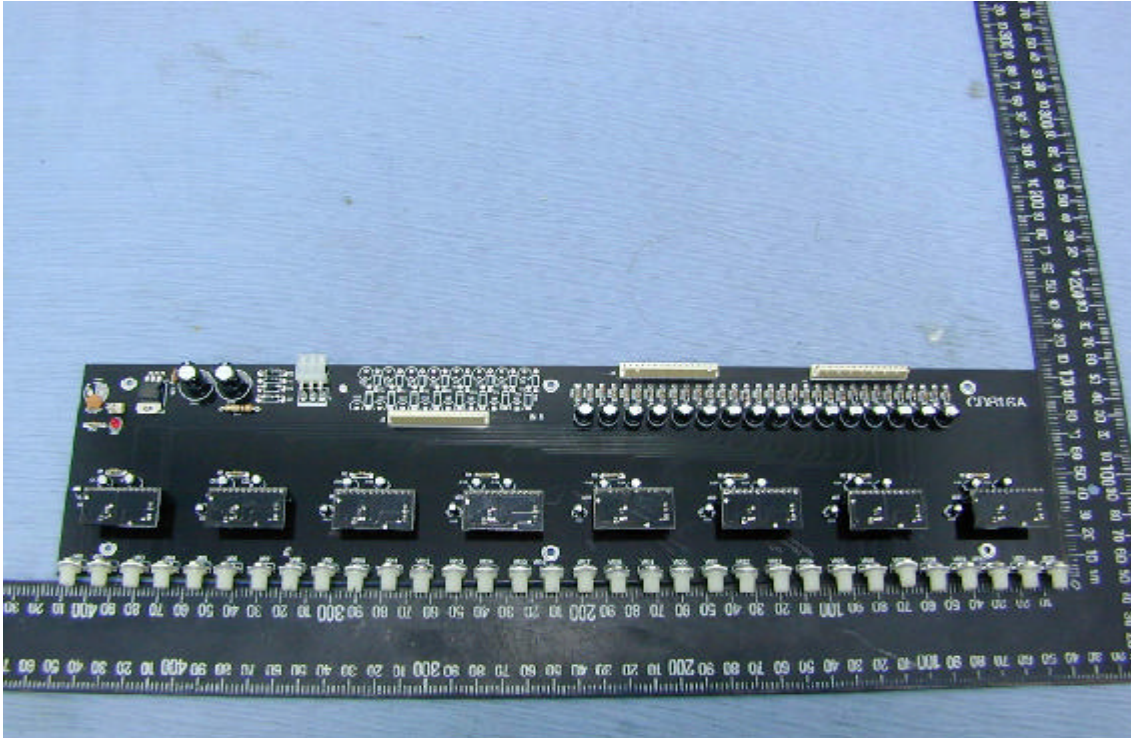

Component Side of Main Board - 1

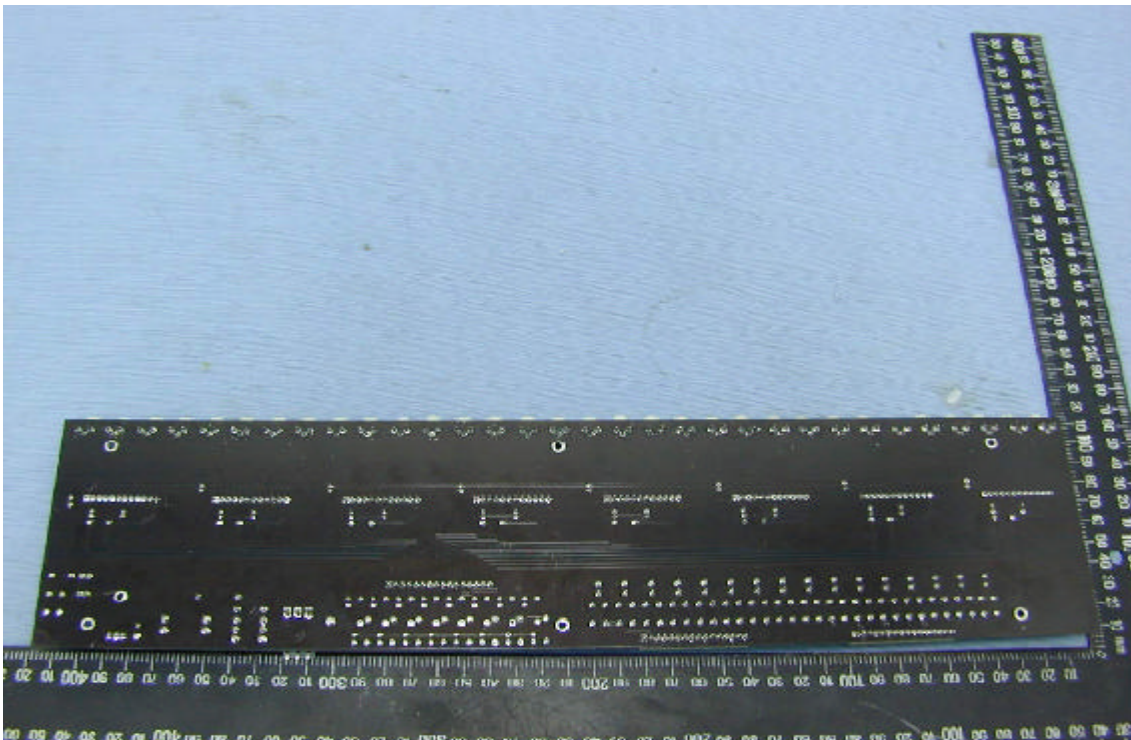

Solder Side of Main Board - 1

PHOTO OF EUT

Model : CD816A

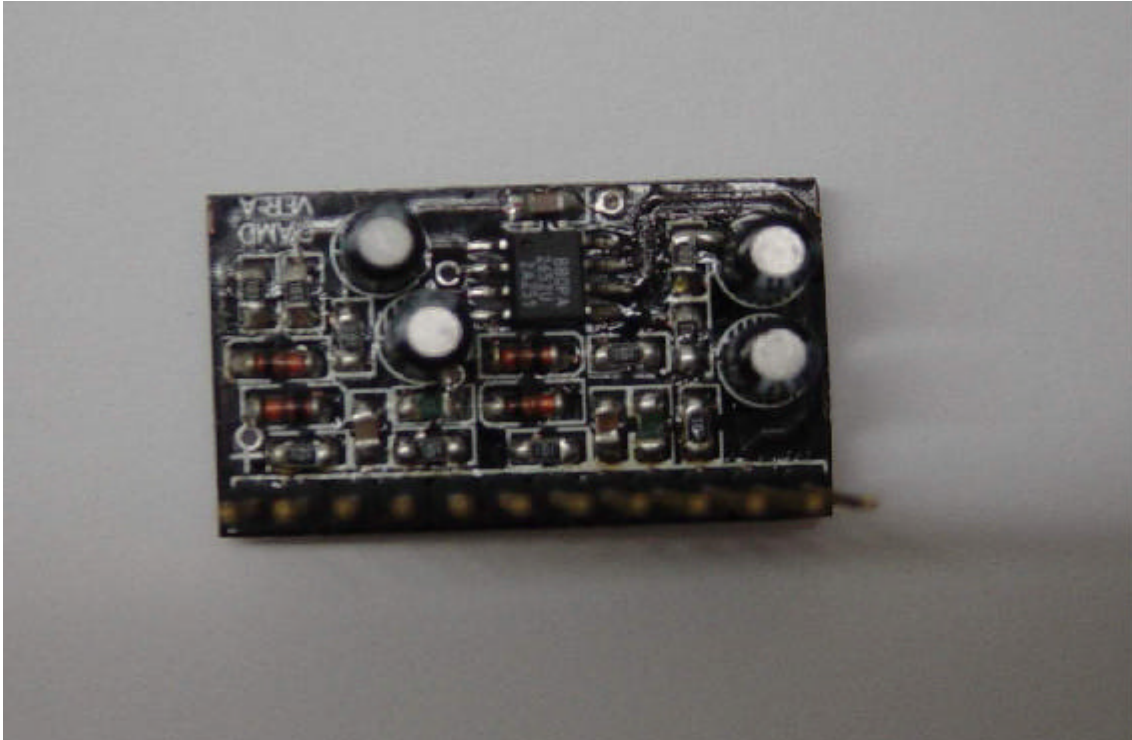

Component Side of Main Board - 2

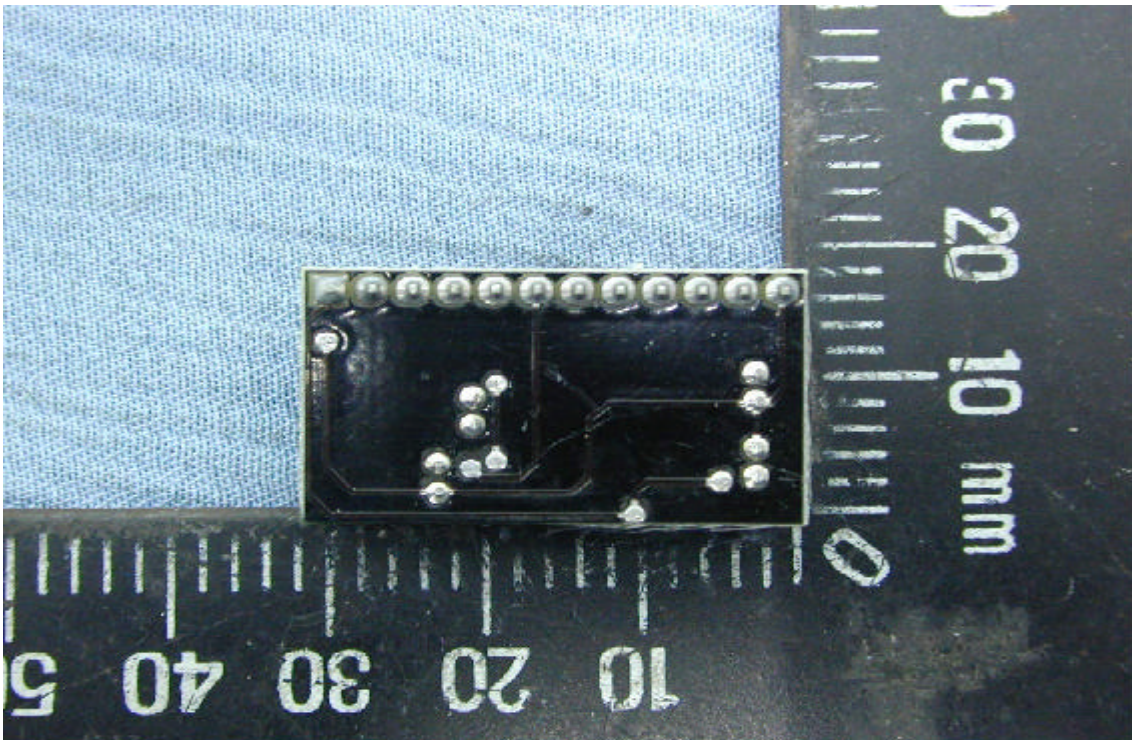

Solder Side of Main Board - 2

PHOTO OF EUT

Model : CD816A



Front View of Adaptor



Rear View of Adaptor

Declaration of Conformity

We(Manufacturer/Importer)

(company name)

(address)

declares under our sole responsibility that the product

Product name : Video Distributor & Amplifier

Model No. : CD816XXX

to which this declaration relates is in conformity with the following standard(s) or other normative document(s)

- | | |
|---|---|
| <input checked="" type="checkbox"/> EN 55013 (2001) | <input checked="" type="checkbox"/> EN 61000-6-1 (2001) |
| <input checked="" type="checkbox"/> EN 61000-3-2 (2000) | <input checked="" type="checkbox"/> IEC 61000-4-2 (1995) |
| <input checked="" type="checkbox"/> EN 61000-3-3 (1995) | <input checked="" type="checkbox"/> IEC 61000-4-3 (1995) |
| + A1 (2001) | <input checked="" type="checkbox"/> IEC 61000-4-4 (1995) |
| | <input checked="" type="checkbox"/> IEC 61000-4-5 (1995) |
| | <input checked="" type="checkbox"/> IEC 61000-4-6 (1996) |
| | <input checked="" type="checkbox"/> IEC 61000-4-8 (1993) |
| | <input checked="" type="checkbox"/> IEC 61000-4-11 (1994) |

following the provisions of 89/336/EEC Directive

Place: _____ Signature: _____

Date : _____ Full name: _____



Title: _____

EMC Laboratory Authorisation

Aut. No.: ELA 183

EMC Laboratory: **HomeTek Technology Inc.**
P.O.Box 13-131, Pan-Chiao City,
No. 67-9, Shi-Men Rd., Tu-Chen City,
Taipei Shien
Taiwan R.O.C.

Scope of
Authorization: **All CENELEC standards [ENs] for EMC that are listed on the
accompanying page, and, all of the corresponding CISPR,
IEC, and ISO EMC standards that are listed on the
accompanying page.**

Nemko has assessed the testing facilities, qualifications and testing practices and the relevant part of the organization. The above-mentioned EMC Laboratory has been validated against EN 45001 and ISO 17025 and found to be compliant. The laboratory also fulfils the conditions described in Nemko Document ELA-INFO-10. During Nemko's visit it was found that the EMC Laboratory is capable of performing tests within the Scope of Authorisation given on the accompanying page(s).

Accordingly, Nemko will accept test reports from the laboratory as a basis for attesting conformity to these EMC Standards under either the European Union EMC Directive (89/336/EEC) or, when applicable, the national standards of countries Nemko has been authorised to attest conformity with.

In order to maintain the Authorisation, the information given in the pertinent ELA-INFO-10 must be carefully followed. Nemko is to be promptly notified about any changes in the situation at the EMC Laboratory, which may affect the basis for this Authorisation. The Authorisation may be withdrawn at any time if the conditions are no longer considered to be fulfilled.

The Authorisation is valid through 31 December 2004.

Oslo, 28 November 2002

For Nemko AS:

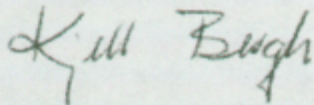

Kjell Bergh, Nemko Group EMC Co-ordinator

EMC Laboratory Authorisation

Aut. No.: ELA 183

SCOPE OF AUTHORIZATION

GENERIC & PRODUCT-FAMILY STANDARDS

EN 50081-1:1992 EN 61000-6-3: 2001 IEC 61000-6-3:1996 (mod)	EN 50082-1 :1997 EN 61000-6-1:2001 IEC 61000-6-1:1997 (mod)	EN 61000-6-2:1999 IEC 61000-6-2:1999 EN 61000-6-2: 2001 IEC 61000-6-2:1999 (mod)
EN 50081-2:1993 EN 61000-6-4 : 2001 IEC 61000-6-4:1997 (mod)	EN 55014-1:1993 + A1:1997 + A2 :1999 CISPR 14:1993 + A1:1996 + A2 :1998 EN 55014-1 :2000 + A1 :2001 CISPR 14-1 :2000 + A1 :2001	EN 55014-2:1997 CISPR 14-2:1997
EN 61000-3-2:1995 + A1:1998 + A2:1998 + A14 :2000 IEC 61000-3-2:1995 + A1:1997 + A2:1998 EN 61000-3-2 :2000 IEC 61000-3-2 :2000 (mod) + A1 :2001	EN 61000-3-3 :1995 + A1 :2001 IEC 61000-3-3 :1994 + A1 :2001 EN 61000-3-11 :00 IEC 61000-3-11 :00	EN 55022:1994 + A1:1995 + A2:1997 CISPR 22:1993 + A1:1995 + A2:1996 EN 55022:1998 + A1 :2000 CISPR 22:1997 + A1 :2000
EN 55024:1998 + A1 :2001 CISPR 24:1997 + A1 :2001	EN 50091-2:1995	EN 60945:1997 IEC 60945:1996
EN 55013: 1990 + A12 :1994 + A13 :1996 + A14 :1999 CISPR 13 :1975 + A1 :1983 (mod) EN55013: 2001 CISPR 13 : 2001 (mod)		

BASIC STANDARDS

EN 61000-4-2:1995 + A1:98 IEC 61000-4-2:1995 + A1:98 EN 60801-1:1993 IEC 801.2:1991 IEC 801.2:1984	EN 61000-4-3:1996 + A1:98 IEC 61000-4-3:1995 + A1:98 IEC 801.3:1984 ENV 50140:1993 + ENV 50204:1995	EN 61000-4-4:1995 IEC 61000-4-4:1995 IEC 801.4:1990
EN 61000-4-5:1995 IEC 61000-4-5:1995 ENV 50142:1994	EN 61000-4-6:1996 IEC 61000-4-6:1996 ENV 50141:1993	EN 61000-4-8:1993 IEC 61000-4-8:1993
EN 61000-4-11:1994 IEC 61000-4-11:1994		

Oslo, 28 November 2002

Kjell Bergh, Nemko Group EMC Co-ordinator