

HomeTek Technology Inc.

ADDRESS: No. 67-9, Shir Men Road, Tu Cheng City,
Taipei Hsien

PHONE : 886-2-22608375 FAX : 886-2-22748013

E - mail : hometek@ms15.hinet.net

CERTIFICATE OF COMPLIANCE

EUT : Video Interference Blocker
MODEL NO. : CHB00XXXT
Receipt Date : 06/15/2006 Final Test Date: 06/26/2006
REPORT # : EB5F011
APPLICANT : SMART CABLING & TRANSMISSION CORP.
ADDRESS : 10F, No. 493, Chung-Cheng Rd.,
Hsin Tien City, Taipei 231, Taiwan, R. O. C.

Measurement procedure used:

EMI: EN 55022 Class B (1998) + A1 (2000) + A2 (2003),

EN 61000-3-2 (2000), EN 61000-3-3 (1995) + A1 (2001)

EMS: EN 55024 (1998) + A1 (2001) + A2 (2003):

IEC 61000-4-2 (2001), IEC 61000-4-3 (2002), IEC 61000-4-4 (2004), IEC 61000-4-5 (2001),

IEC 61000-4-6 (2003) + A1 (2004), IEC 61000-4-8 (2001), IEC 61000-4-11 (2004)

We hereby show that:

The measurements shown in this test report were made in accordance with the procedures given in **EUROPEAN COUNCIL DIRECTIVE 89/336/EEC**, and the energy emitted by the equipment was found to be within the limits applicable.

This test result of this report applies to above tested sample only.

This test report shall not be reproduce in part without written approval of HomeTek Technology Inc.

APPROVED BY :  6/29/2006

ALAIN LIN / Supervisor



TABLE OF CONTENTS 1

GENERAL INFORMATION 4

MODIFICATION LIST 5

CONDUCTED POWER LINE TEST 6

1 TEST INSTRUMENTS & FACILITIES 6

2 TEST PROCEDURE 6

3 TEST SETUP 7

4 CONFIGURATION OF THE EUT 9

5 EUT OPERATING CONDITION 13

6 LIMIT OF CONDUCTED POWER LINE EMISSION CLASS B 13

7 RESULT OF CONDUCTED POWER LINE TEST 13

8 CONDUCTED POWER LINE TEST DATA (PAGE 1) 14

9 CONDUCTED POWER LINE TEST DATA (PAGE 2) 15

10 CONDUCTED POWER LINE TEST DATA (PAGE 3) 16

11 CONDUCTED POWER LINE TEST DATA (PAGE 4) 17

RADIATED EMISSION TEST 18

1 TEST INSTRUMENTS & FACILITIES 18

2 TEST PROCEDURE 19

3 TEST SETUP 19

4 CONFIGURATION OF THE EUT 21

5 EUT OPERATING CONDITION 21

6 LIMIT OF RADIATED EMISSION CLASS B 21

7 RESULT OF RADIATED EMISSION TEST 21

8 RADIATED EMISSION TEST DATA (PAGE 1) 22

9 RADIATED EMISSION TEST DATA (PAGE 2) 23

HARMONICS TEST 24

1 TEST INSTRUMENTS & FACILITIES 24

2 TEST PROCEDURE 24

3 TEST SETUP 24

4 CONFIGURATION OF THE EUT 24

5 OPERATION CONDITION OF EUT 24

6 TEST DATA & LIMIT 24

7 PHOTOS OF TEST CONFIGURATION PLEASE REFER TO APPENDIX A. 24

8 HARMONICS TEST DATA (PAGE 1~2) 25

VOLTAGE FLUCTUATIONS TEST 27

1 TEST INSTRUMENTS & FACILITIES 27

2 TEST PROCEDURE 27

3 TEST SETUP 27



4 CONFIGURATION OF THE EUT27

5 OPERATION CONDITION OF EUT27

6 TEST DATA & LIMIT27

7 PHOTOS OF TEST CONFIGURATION PLEASE REFER TO APPENDIX A.27

8 VOLTAGE FLUCTUATIONS TEST DATA (PAGE 1)28

ELECTROSTATIC DISCHARGE IMMUNITY TEST (ESD).....29

1 TEST INSTRUMENTS & FACILITIES29

2 TEST PROCEDURE29

3 TEST SETUP29

4 CONFIGURATION OF THE EUT30

5 EUT OPERATION CONDITION30

6 TEST CONDITION30

7 PERFORMANCE CRITERIA30

8 TEST RESULT31

RADIO FREQUENCY ELECTROMAGNETIC FIELD IMMUNITY TEST (RF)32

1 TEST INSTRUMENTS & FACILITIES32

2 TEST PROCEDURE32

3 TEST SETUP33

4 CONFIGURATION OF THE EUT34

5 OPERATION CONDITION OF EUT34

6 TEST CONDITION34

7 PERFORMANCE CRITERIA34

8 TEST RESULT35

ELECTRICAL FAST TRANSIENT/BURST IMMUNITY TEST (EFT).....36

1 TEST INSTRUMENTS & FACILITIES36

2 TEST PROCEDURE36

3 TEST SETUP36

4 CONFIGURATION OF THE EUT37

5 OPERATION CONDITION OF EUT37

6 TEST CONDITION37

7 PERFORMANCE CRITERIA37

8 TEST RESULT38

SURGE IMMUNITY TEST39

1 TEST INSTRUMENTS & FACILITIES39

2 TEST PROCEDURE39

3 TEST SETUP39

4 TEST LEVELS40

5 CONFIGURATION OF THE EUT40

6 EUT OPERATION CONDITION40



7 CONDITIONS DURING TESTING40

8 PERFORMANCE CRITERIA41

9 TEST RESULT41

IMMUNITY TEST TO CS CONDUCTED DISTURBANCE.....42

1 TEST INSTRUMENTS & FACILITIES42

2 TEST PROCEDURE42

3 TEST SETUP43

4 TEST LEVELS44

5 CONFIGURATION OF THE EUT44

6 EUT OPERATION CONDITION44

7 CONDITIONS DURING TESTING44

8 PERFORMANCE CRITERIA45

9 TEST RESULT45

POWER FREQUENCY MAGNETIC FIELD IMMUNITY TEST.....46

1 TEST INSTRUMENTS & FACILITIES46

2 TEST STANDARD46

3 TEST SETUP46

4 TEST LEVELS47

5 CONFIGURATION OF THE EUT47

6 OPERATION CONDITION OF EUT47

7 CONDITIONS DURING TESTING47

8 PERFORMANCE CRITERIA47

9 TEST RESULTS48

VOLTAGE DIPS, SHORT INTERRUPTIONS IMMUNITY TEST.....49

1 TEST INSTRUMENTS & FACILITIES49

2 TEST PROCEDURE49

3 TEST SETUP49

4 TEST LEVELS50

5 CONFIGURATION OF THE EUT50

6 EUT OPERATION CONDITION50

7 CONDITIONS DURING TESTING50

8 PERFORMANCE CRITERIA51

9 TEST RESULT51

APPENDIX A

PHOTOS OF TEST CONFIGURATION

APPENDIX B

PHOTOS OF EUT

GENERAL INFORMATION

- 1 APPLICANT : SMART CABLING & TRANSMISSION CORP.
- 2 ADDRESS : 10F, No. 493, Chung-Cheng Rd.,
Hsin Tien City, Taipei 231, Taiwan, R. O. C.
- 3 MANUFACTURER : SMART CABLING & TRANSMISSION CORP.
- 4 ADDRESS : 10F, No. 493, Chung-Cheng Rd.,
Hsin Tien City, Taipei 231, Taiwan, R. O. C.
- 5 DESCRIPTION OF EUT :
- EUT : Video Interference Blocker
- Model : CHB00XXXT
- Serial # : N/A

5.1 The difference between series of models CHB00XXXT are as shown below:

- (1) The first “X” represents different system input.
- (2) The second “X” represent different accessory.
- (3) The third “X” represent different color.

The PCB layout is similar. The worst case of EMC test data were shown in this test report.

6 FEATURES OF EUT :

Please refer to user manual or product specification.

MODIFICATION LIST

THE FOLLOWING ACCESSORIES WERE ADDED TO THE EUT DURING TESTING :

NO MODIFICATION BY HOMETEK TECHNOLOGY INC.

CONDUCTED POWER LINE TEST

1 TEST INSTRUMENTS & FACILITIES

The following test Instruments was used during the conducted test :

Item	Instruments/ Facilities	Specification	Manufacturer	Model #	Date Of Cal.
1	EMI Receiver	9KHz ~ 30MHz	ROHDE & SCHWARZ	ESHS 30 844827/007	FEB/2006
2	LISN (for EUT)	50Ω/50uH/100A 150KHz ~ 30MHz	SCHWARZ BECK	NNLK 8121 8121370	OCT/2005
3	LISN (for Support Unit)	50Ω/50uH/10A 9KHz ~ 30MHz	ROHDE & SCHWARZ	ESH3-Z5 846128/007	MAR/2006
4	Terminator	50Ω	N/A	N/A	NOV/2005
5	Attenuation	50Ω/10dB	Mini-Circuit	NAT-10 AT-002	JUL/2005
6	Cable	5.4m	SUHNER	RG-223 CON2-002	AUG/2005
7	ESXS-K1 (software)	Version 2.03b 9KHz ~ 30MHz	ROHDE & SCHWARZ	1082.9678.02 840.913/246	N/A

Note : Items 1 ~ 6 were calibrated within period of 1 year.

2 TEST PROCEDURE

- 2.1 The EUT was tested according to **EN55022 Class B**.
- 2.2 The EUT was placed 0.4 meter from the conducting wall of shielding room and kept at least 0.8 meter from any other grounded conducting surface.
- 2.3 The frequency range form 0.15 MHz to 30 MHz was investigated.
- 2.4 The LISN used was 50 Ohm / 50 uHenry as specified by **EN55022**.
- 2.5 All the support peripherals are connect to the other LISN.
- 2.6 Cables and peripherals were moved to find the maximum emission levels for each frequency.

3 TEST SETUP

3.1 Typical : Setup Of Conducted Test

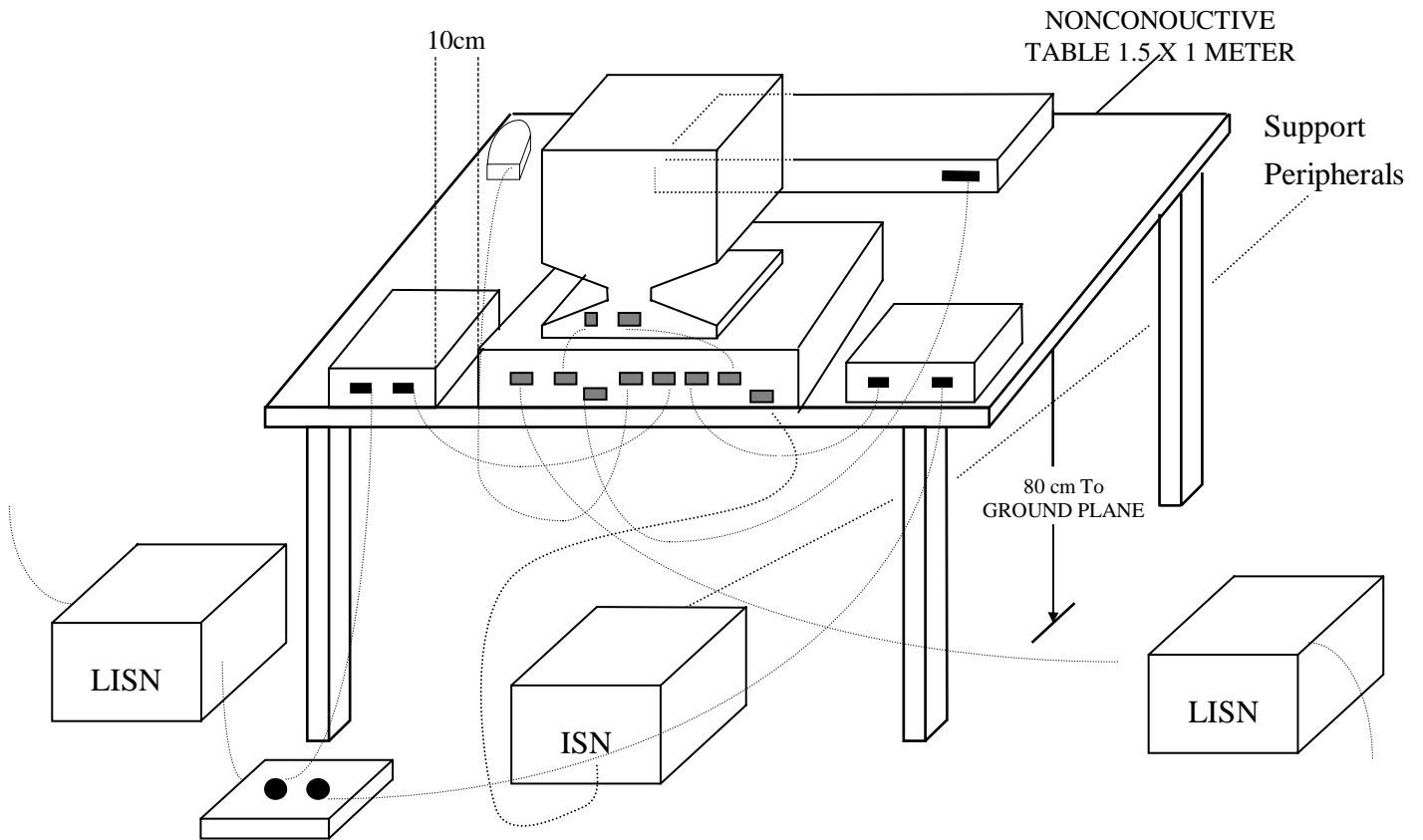

(Details for setup configuration, please refer to appendix A.)

3.2 Block Diagram Of Conducted Test

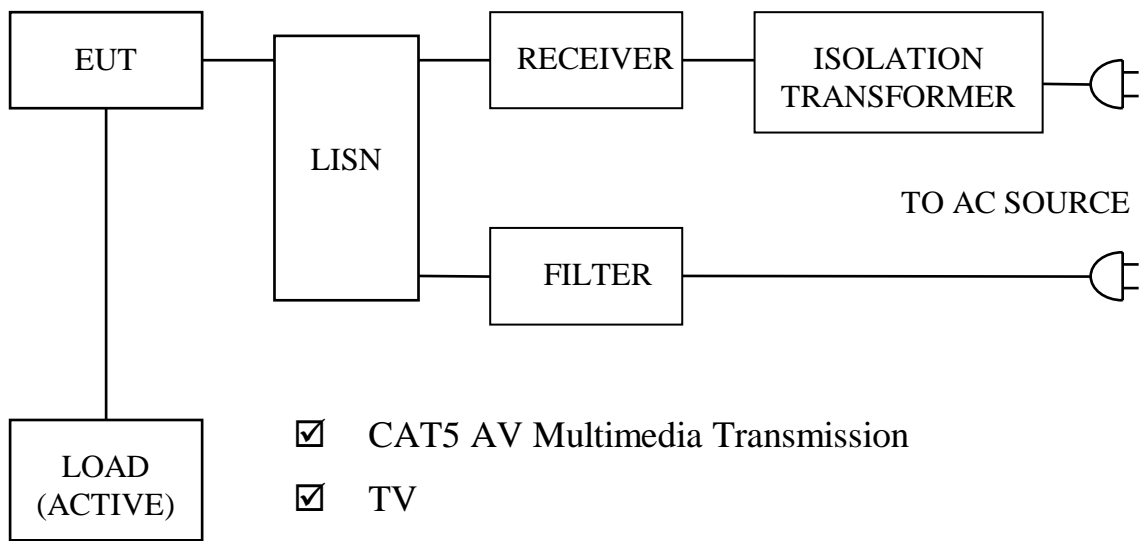

- CAT5 AV Multimedia Transmission
- TV
- DV
- Video Interference Blocker

4 CONFIGURATION OF THE EUT

The EUT was configured according to **EN55022**. All I/O ports were connected to the appropriate peripherals. All peripherals and cables are listed below (including internal device) :

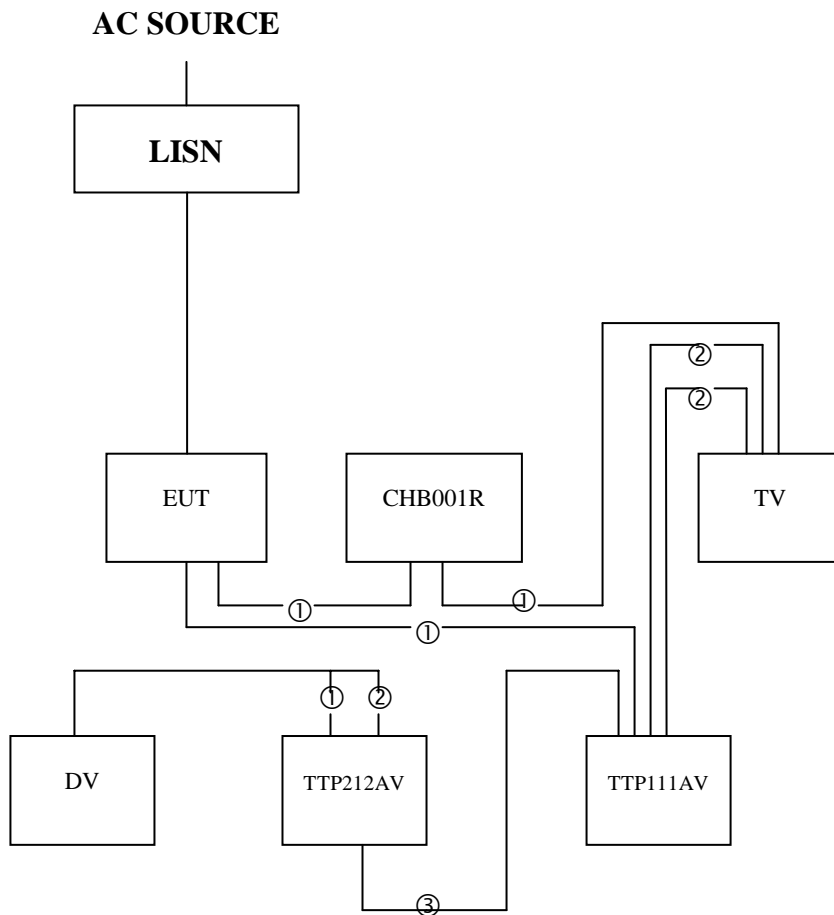

- ① Video Cable
- ② Audio Cable
- ③ RJ-45 Cable

Figure 1



4.1 EUT

EUT Type : Proto Type Engineer Type Mass Production
Condition when received : Good Damage : _____
Device : Video Interference Blocker
Applicant : SMART CABLING & TRANSMISSION CORP.
Manufacturer : SMART CABLING & TRANSMISSION CORP.
Model Number : CHB00XXXT
Serial Number : N/A
FCC ID : N/A
Video Input Port : Metal Type Connector
Video Output Port : Metal Type Connector
Power Cord (AC) : 2 pin
Power Cord (AC) : Un-Shielded, 1.8 m, 2 pin
Power Supply Type : Linear Power Adapter

4.2 PERIPHERALS

DV

Manufacturer : SONY
Model Number : DCR-PC110
Serial Number : 1158142
FCC ID : FCC DoC
Data Cable 1 : Shielded, 1.8 m, Connect to the Video port
Data Cable 2 : Shielded, 1.8 m, Connect to the Audio port
Power Cord : Un-Shielded, 1.8 m



TV

Manufacturer : TCL
Model Number : 1419A
Serial Number : N/A
FCC ID : N/A
Data Cable 1 : Shielded, 1.0 m, Connect to the Video port
Data Cable 2 x 2 : Shielded, 1.5 m, Connect to the Audio port
Power Cord : Un-Shielded, 1.8 m

CAT5 AV Multimedia Transmission 1

Manufacturer : SMART CABLING & TRANSMISSION CORP.
Model Number : TTP212AV
Serial Number : N/A
FCC ID : N/A
Data Cable 1 : Shielded, 1.8 m, Connect to the Video port
Data Cable 2 : Shielded, 1.8 m, Connect to the Audio port
Data Cable 3 : Un-Shielded, 1.0 m, Connect to the RJ-45 port
Power Cord : N/A

CAT5 AV Multimedia Transmission 2

Manufacturer : SMART CABLING & TRANSMISSION CORP.
Model Number : TTP111AV
Serial Number : N/A
FCC ID : N/A
Data Cable 1 : Shielded, 1.0 m, Connect to the Video port
Data Cable 2 x 2 : Shielded, 1.5 m, Connect to the Audio port
Data Cable 3 : Un-Shielded, 1.0 m, Connect to the RJ-45 port
Power Cord : N/A



Video Interference Blocker

Manufacturer : SMART CABLING & TRANSMISSION CORP.
Model Number : CHB001R
Serial Number : N/A
FCC ID : N/A
Data Cable x 2 : Un-Shielded, 1.0 m, Connect to the Video port
Power Cord : N/A

Power Adapter

Manufacturer : YN
Model Number : YAA-2400500E
Serial Number : N/A
FCC ID : N/A
Data Cable : N/A
Power Cord : Un-Shielded, 1.8 m

4.3 REMARK : N/A

5 EUT OPERATING CONDITION

- 5.1 The operation frequency of the EUT is none.
- 5.2 Configure the EUT according to the **EN 55022 Class B**.

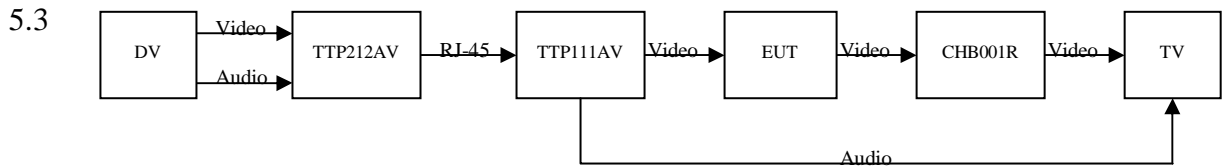

- 5.4 TV receives DV's video signal (color bar) through EUT, CHB001R, TTP111AV, TTP212AV via video cable or RJ-45 cable.
- 5.5 TV receives DV's audio signal (1KHz audio) through TTP111AV and TTP212AV via audio cable or RJ-45 cable.
- 5.6 TV display color bar and measure the emission noise.
- 5.7 **The photos of conducted test configuration, please refer to appendix A.**

6 LIMIT OF CONDUCTED POWER LINE EMISSION CLASS B

Frequency Range	Quasi Peak	Average
0.15 ~ 0.5 MHz	66 - 56 dBuV	56 - 46 dBuV
0.5 ~ 5 MHz	56 dBuV	46 dBuV
5 ~ 30 MHz	60 dBuV	50 dBuV

7 RESULT OF CONDUCTED POWER LINE TEST

- 7.1 The frequency range from 0.15 MHz to 30 MHz was investigated. All readings are quasi-peak values and average.
- 7.2 IF bandwidth : 9 kHz, Meas Time : 1 sec.
- 7.3 Temperature : 28 °C, Humidity : 56 % RH.
- 7.4 Deviations from the test standards and rules : None.
- 7.5 The conducted test result were gained by following procedures :
 Level = Reading Level + Insertion Loss of LISN + Cable Loss
 (All calculation were done by ESHS30 EMI test receiver.)
- 7.6 Result : **PASSED**

8 CONDUCTED POWER LINE TEST DATA (PAGE 1)

HomeTek EMC LAB. TEL :886-2-22608375

24 Jun 2006 10:15

CONDUCTED EMISSIONS

EUT: Video Interference Blocker
 Manuf: 5F011
 Op Cond: LINE 1
 Operator: Makoto
 Test Spec: FOR EN55022 CLASS B
 Comment: 230V/50Hz
 CHB001T
 Result File: 5f01111c.dat : CHB001T

Prescan Measurement: Detectors: X PK / + AV
 Meas Time: see scan settings
 Subranges: 16
 Acc Margin: 55 dB

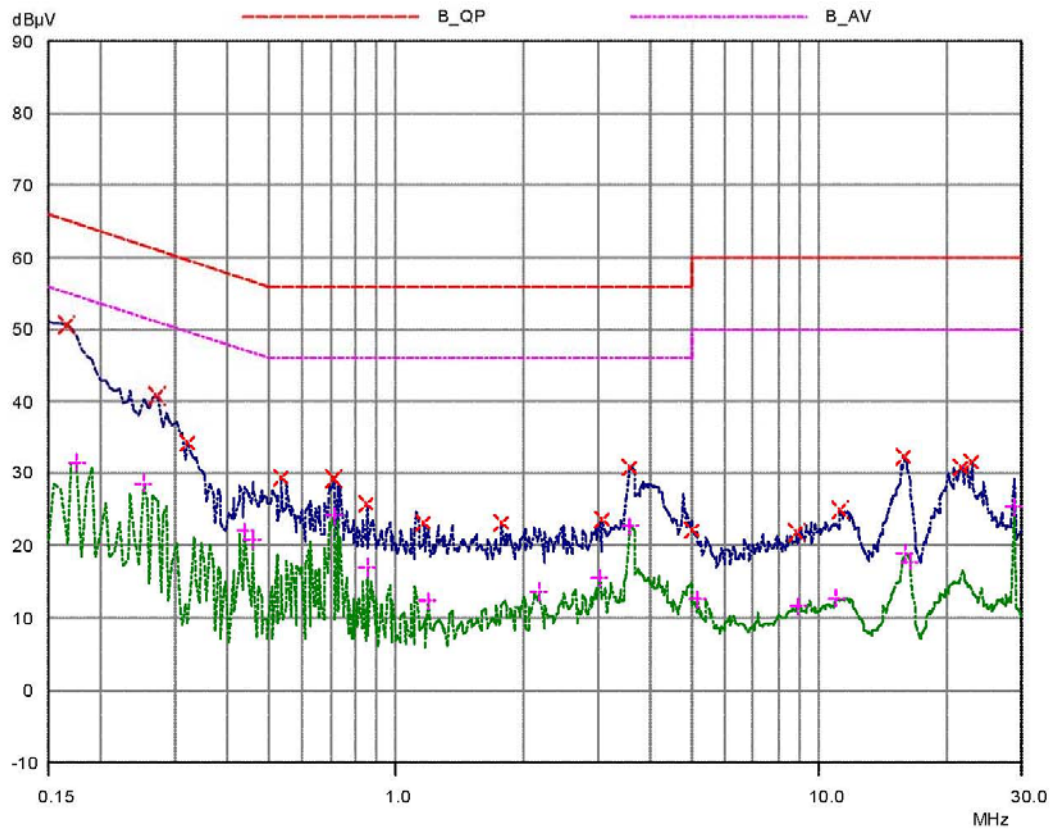



9 CONDUCTED POWER LINE TEST DATA (PAGE 2)

HomeTek EMC LAB. TEL :886-2-22608375

24 Jun 2006 10:15

CONDUCTED EMISSIONS

EUT: Video Interference Blocker
 Manuf: 5F011
 Op Cond: LINE 1
 Operator: Makoto
 Test Spec: FOR EN55022 CLASS B
 Comment: 230V/50Hz
 CHB001T
 Result File: 5f01111c.dat : CHB001T

Prescan Measurement: Detectors: X PK / + AV
 Meas Time: see scan settings
 Subranges: 16
 Acc Margin: 55 dB

Peak Search Results

Frequency MHz	PK Level dBµV	PK Limit dBµV	PK Delta dB
0.165	50.66	65.21	14.55
0.27	40.78	61.12	20.34
0.32	34.24	59.71	25.47
0.535	29.34	56.00	26.66
0.71	29.24	56.00	26.76
0.849	25.70	56.00	30.30
1.164	23.09	56.00	32.91
1.78	23.20	56.00	32.80
3.068	23.54	56.00	32.46
3.565	30.92	56.00	25.08
5.02	22.19	60.00	37.81
8.8	21.79	60.00	38.21
11.17	24.93	60.00	35.07
15.84	32.19	60.00	27.81
21.6	30.85	60.00	29.15
23.0	31.57	60.00	28.43

Frequency MHz	AV Level dBµV	AV Limit dBµV	AV Delta dB
0.175	31.44	54.72	23.28
0.25	28.64	51.76	23.12
0.44	21.94	47.06	25.12
0.455	20.79	46.78	25.99
0.71	24.12	46.00	21.88
0.849	17.01	46.00	28.99
1.178	12.35	46.00	33.65
2.172	13.62	46.00	32.38
3.005	15.45	46.00	30.55
3.565	22.65	46.00	23.35
5.16	12.63	50.00	37.37
8.89	11.68	50.00	38.32
11.01	12.75	50.00	37.25
15.84	19.00	50.00	31.00
16.30999	17.74	50.00	32.26
28.64	25.33	50.00	24.67

* limit exceeded

10 CONDUCTED POWER LINE TEST DATA (PAGE 3)

HomeTek EMC LAB. TEL :886-2-22608375

24 Jun 2006 10:20

CONDUCTED EMISSIONS

EUT: Video Interference Blocker
 Manuf: 5F011
 Op Cond: LINE 2
 Operator: Makoto
 Test Spec: FOR EN55022 CLASS B
 Comment: 230V/50Hz
 CHB001T
 Result File: 5f01121c.dat : CHB001T

Prescan Measurement: Detectors: X PK / + AV
 Meas Time: see scan settings
 Subranges: 16
 Acc Margin: 55 dB

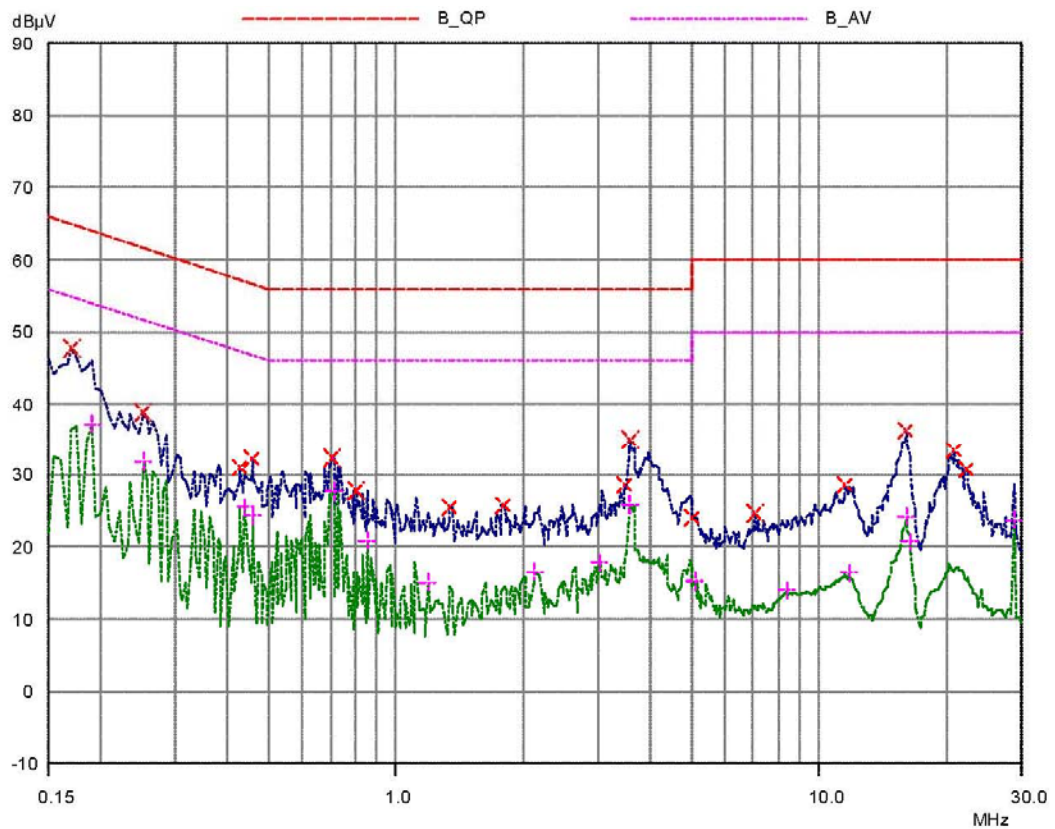



11 CONDUCTED POWER LINE TEST DATA (PAGE 4)

HomeTek EMC LAB. TEL :886-2-22608375

24 Jun 2006 10:20

CONDUCTED EMISSIONS

EUT: Video Interference Blocker
 Manuf: 5F011
 Op Cond: LINE 2
 Operator: Makoto
 Test Spec: FOR EN55022 CLASS B
 Comment: 230V/50Hz
 CHB001T
 Result File: 5f01121c.dat : CHB001T

Prescan Measurement: Detectors: X PK / + AV
 Meas Time: see scan settings
 Subranges: 16
 Acc Margin: 55 dB

Peak Search Results

Frequency MHz	PK Level dBµV	PK Limit dBµV	PK Delta dB
0.17	47.75	64.96	17.21
0.25	38.88	61.76	22.88
0.425	31.09	57.35	26.26
0.455	32.30	56.78	24.48
0.705	32.38	56.00	23.62
0.8	27.83	56.00	28.17
1.339	25.56	56.00	30.44
1.794	25.84	56.00	30.16
3.46	28.57	56.00	27.43
3.565	35.01	56.00	20.99
5.02	24.10	60.00	35.90
7.05	24.70	60.00	35.30
11.47	28.66	60.00	31.34
16.02	36.26	60.00	23.74
20.78	33.44	60.00	26.56
22.3	30.76	60.00	29.24

Frequency MHz	AV Level dBµV	AV Limit dBµV	AV Delta dB
0.19	37.25	54.04	16.79
0.25	31.92	51.76	19.84
0.44	25.56	47.06	21.50
0.455	24.43	46.78	22.35
0.71	27.81	46.00	18.19
0.849	20.90	46.00	25.10
1.178	15.13	46.00	30.87
2.123	16.55	46.00	29.45
3.005	17.86	46.00	28.14
3.565	25.90	46.00	20.10
5.05	15.33	50.00	34.67
8.31	14.05	50.00	35.95
11.69	16.44	50.00	33.56
15.99	24.25	50.00	25.75
16.30999	20.79	50.00	29.21
28.64	23.77	50.00	26.23

* limit exceeded

RADIATED EMISSION TEST

1 TEST INSTRUMENTS & FACILITIES

The following test Instruments was used during the radiated emission test :

Item	Instruments /facilities	Specification	Manufacturer	Model # / S/N#	Date of Cal.
1	OPEN AREA TEST SITE	<input checked="" type="checkbox"/> OATS 3			JUL/2005
2	EMI TEST RECEIVER	20Hz ~ 26.5GHz	ROHDE & SCHWARZ	ESMI 845442/006	FEB/2006
3	PRE-AMPLIFIER	9KHz ~ 3000MHz	ADVANTEST	BB525C 90081001	OCT/2005
4	ANTENNA (BI-LOG)	25MHz ~ 2GHz	SCHAFFNER	CBL6112B S/N : 2614	JUN/2006
5	Attenuation	50Ω/6dB	JYE BAO	FAT-N (M-F) 001	JUL/2005
6	Ferrite Clamp	30 ~ 1000MHz	ADT	FC18 910030	DEC/2005
7	Ferrite Clamp	30 ~ 1000MHz	HomeTek	HFC 001	DEC/2005
8	Cable	10m	SUHNER	RG214/U OS3-003	DEC/2005
9	Cable	14m	BELDEN	9913 OS3-001	DEC/2005
10	EMI 32 (software)	N/A	AUDIX	19991013-0923	N/A

Note : Items 1 ~ 9 were calibrated within period of 1 year.

2 TEST PROCEDURE

- 2.1 The EUT was test according to **EN55022**.
- 2.2 The radiated test was performed at HomeTek Lab's Open Site III.
- 2.3 The frequency range from 30 MHz to 1 GHz, the measurement were made at 10 meters, with a BI-log antenna.

3 TEST SETUP

3.1 TEST SETUP OF OPEN SITE.

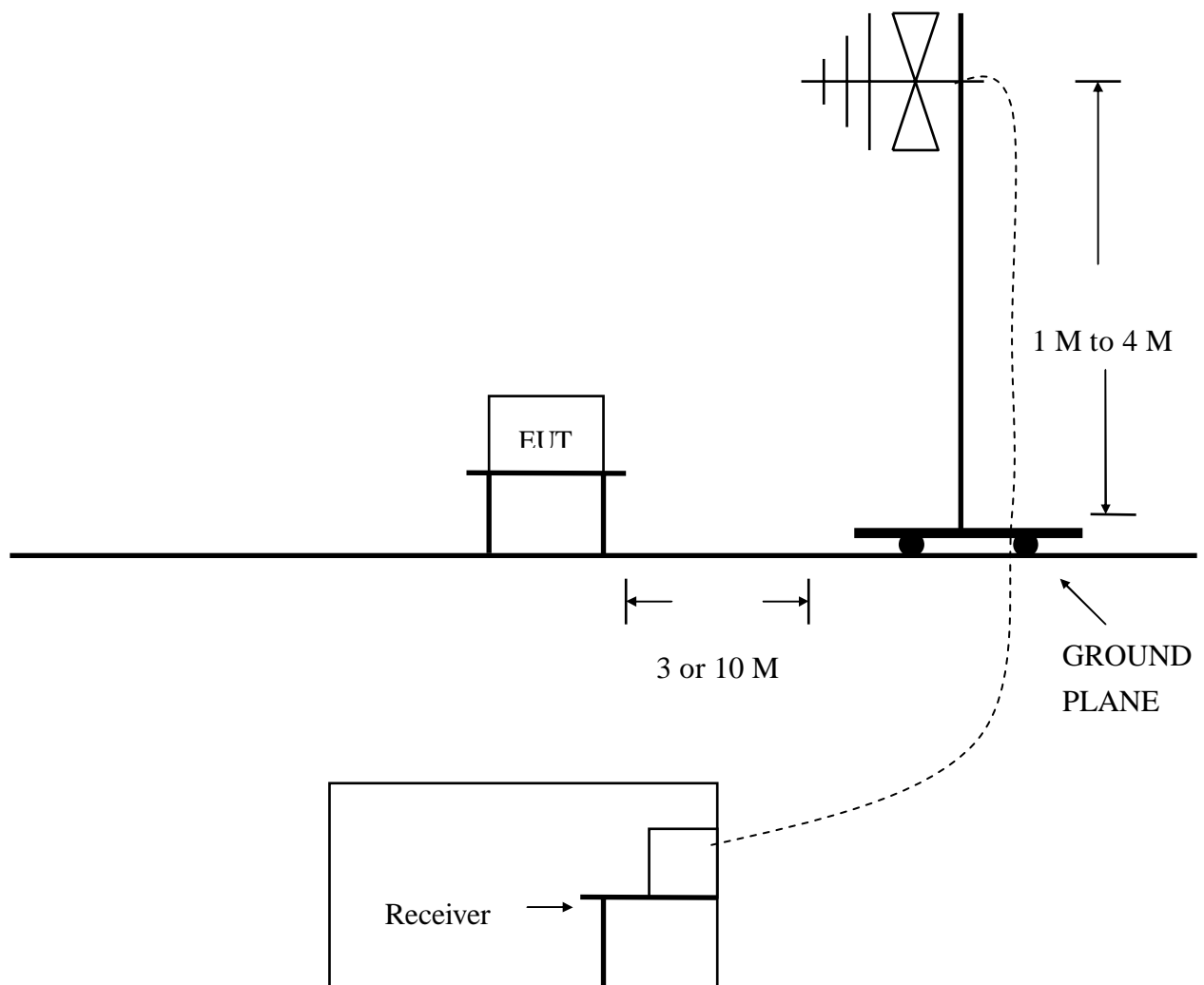

(Details for setup configuration, please refer to appendix A.)

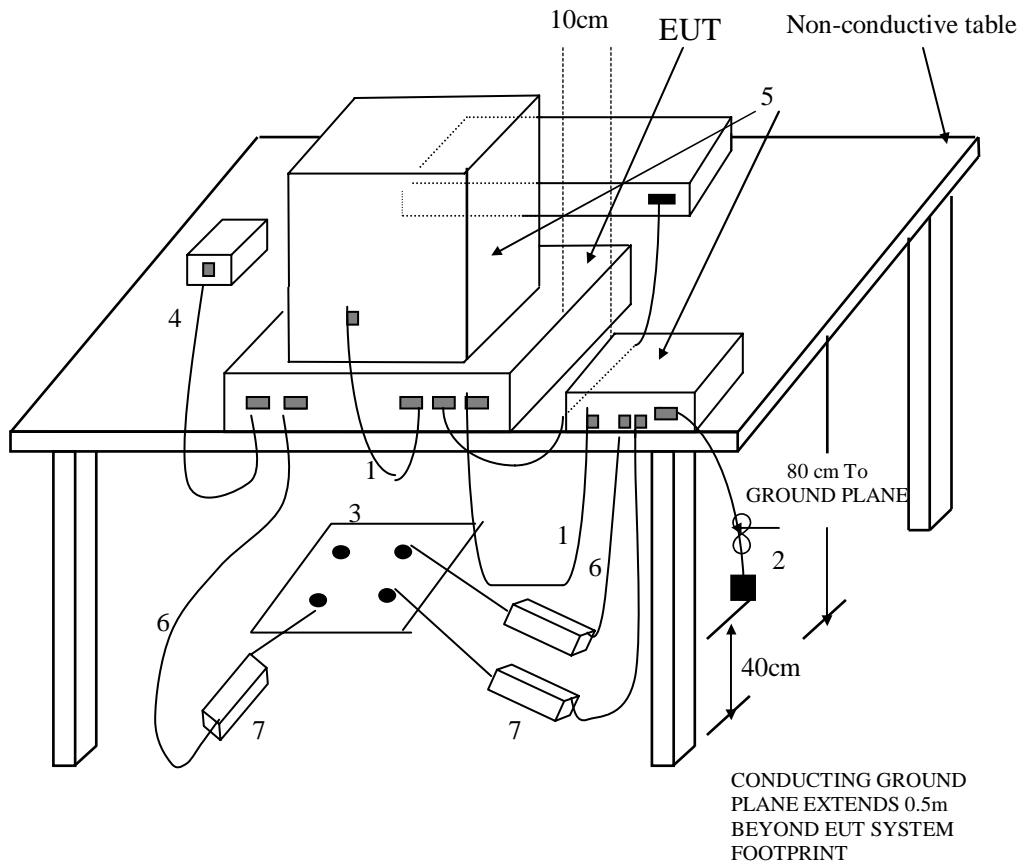

(Details for setup configuration, please refer to appendix A.)

LEGEND:

- 1.If cables, which hang closer than 40 cm to the horizontal metal ground plane cannot be shortened to the appropriate length, the excess shall be folded back and forth forming a bundle 30 m to 40 cm long.
- 2.The end of I/O signal cables which are not connected to a peripheral may be terminated, if required for proper operation using correct terminating impedance.
- 3.Mains junction box(es) shall be flush with, and bonded directly to , the metal ground plane.
NOTE if used, the AMN shall be installed under the horizontal metal ground plane.
- 4.Cables of hand-operated devices such as keyboards, mice, etc. shall be placed as for normal usage.
- 5.Peripherals shall be placed at a distance of 10 cm from each other and from the controller, except for the monitor which, if for an acceptable installation practice, shall be placed directly on top of the controller.
- 6.Mains cables, telephone lines or other connections to auxiliary equipment located outside the test area shall drape to the floor, be fitted with ferrite clamps or ferrite tubes placed on the floor at the point where the cable reaches the floor and then routed to the place where they leave the turntable. No extension cords shall be used to mains receptacle.
- 7.Ferrite clamps or ferrite tubes with similar characteristics (as defined in 10.4). No more than one cable per clamp.

Test Configuration Tabletop Equipment Radiated Measurement

4 CONFIGURATION OF THE EUT

Same as “Conducted Power Line test”, section 4

5 EUT OPERATING CONDITION

5.1 Same as “Conducted Power Line test”, section 5

5.2 The radiated emission in the frequency range from 30 MHz - 1000 MHz was test in a horizontal and vertical polarization at HomeTek Lab’s open site III.

5.3 The photos of radiated test configuration, please refer to appendix A.

6 LIMIT OF RADIATED EMISSION CLASS B

Frequency (MHz)	Measurement Distance	Limit (dBuV/m)
30 - 230	10 (M)	30
230 - 1000	10 (M)	37

7 RESULT OF RADIATED EMISSION TEST

7.1 The frequency range from 30 MHz to 1 GHz was investigated.

7.2 All readings below or equal 1 GHz are quasi-peak or peak values with resolution bandwidth of 120 KHz.

7.3 The measurements were made at 10 meters of HomeTek Lab’s open site III.

7.4 Temperature : 31 °C, Humidity : 51 % RH.

7.5 Deviation form the test standards and rules : None.

7.6 The radiated emission result were gained by the following method :

Level = Reading Level + Probe Factor (Antenna Factor) + Cable Loss – Preamp Factor

Over Limit = Level – Limit Line

7.7 Result : **PASSED**



8 RADIATED EMISSION TEST DATA (PAGE 1)



HomeTek Technology Inc.

No 67-9, Shi-Men Rd., Tu-Chen City, Taipei County, Taiwan R.O.C. Tel:02-22608375 Fax:02-22748013

Data#: 2 File#: 5F011.EMI

Date: 2006-06-26 Time: 19:54:44

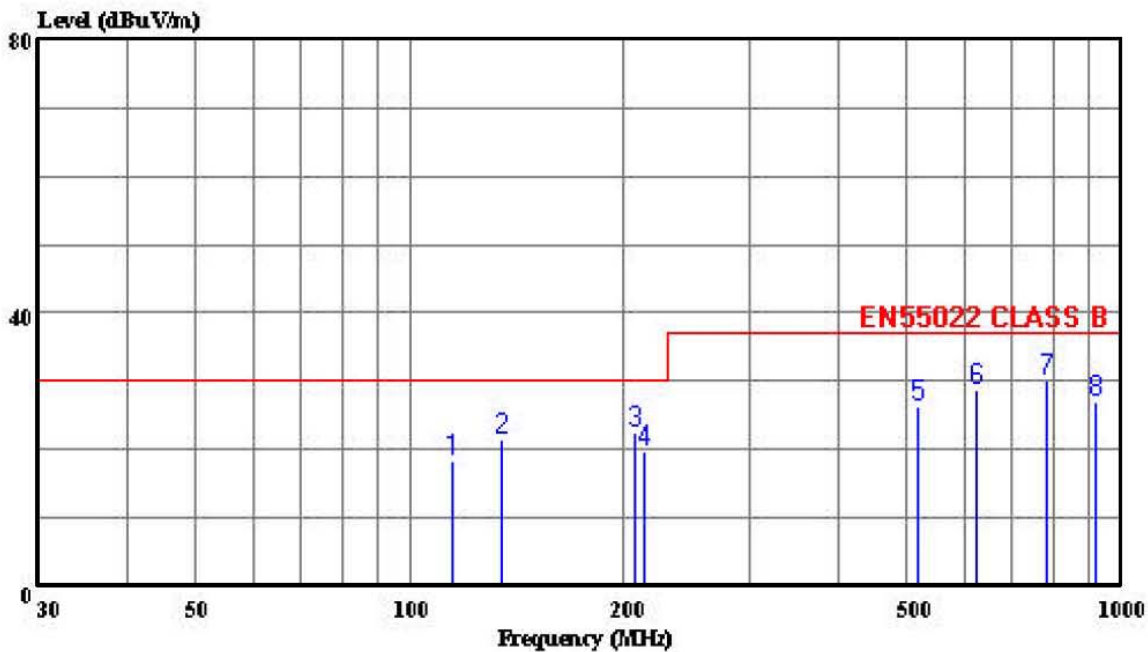

Trace:

Ref Trace:

Condition: EN55022 CLASS B 10m CHASE 2614 060506 HORIZONTAL
 eut : Video Interference Blocker
 power: 230V/50Hz
 memo : CHB001T

Page: 1

	Limit	Over	ReadAntenna	Cable	Preamp	Remark		
Freq	Line	Limit	Level	Factor	Loss	Factor		
MHz	dBuV/m	dBuV/m	dB	dB	dB	dB		
1	114.993	18.18	30.00	-11.82	30.23	12.25	1.46	25.76 Peak
2	134.000	21.52	30.00	-8.48	34.21	11.46	1.58	25.72 Peak
3	206.480	22.44	30.00	-7.56	36.95	9.10	2.01	25.62 Peak
4	214.000	19.86	30.00	-10.14	34.33	9.10	2.04	25.61 Peak
5	518.553	26.45	37.00	-10.55	30.07	17.87	3.41	24.89 Peak
6	627.627	28.82	37.00	-8.18	30.65	18.77	3.81	24.40 Peak
7	782.573	30.01	37.00	-6.99	29.89	19.70	4.26	23.84 Peak
8	917.280	26.93	37.00	-10.07	24.65	20.50	5.15	23.36 Peak



9 RADIATED EMISSION TEST DATA (PAGE 2)



HomeTek Technology Inc.

No 67-9, Shi-Men Rd., Tu-Chen City, Taipei County, Taiwan R.O.C. Tel:02-22608375 Fax:02-22748013

Data#: 1 File#: 5F011.EMI

Date: 2006-06-26 Time: 19:01:52

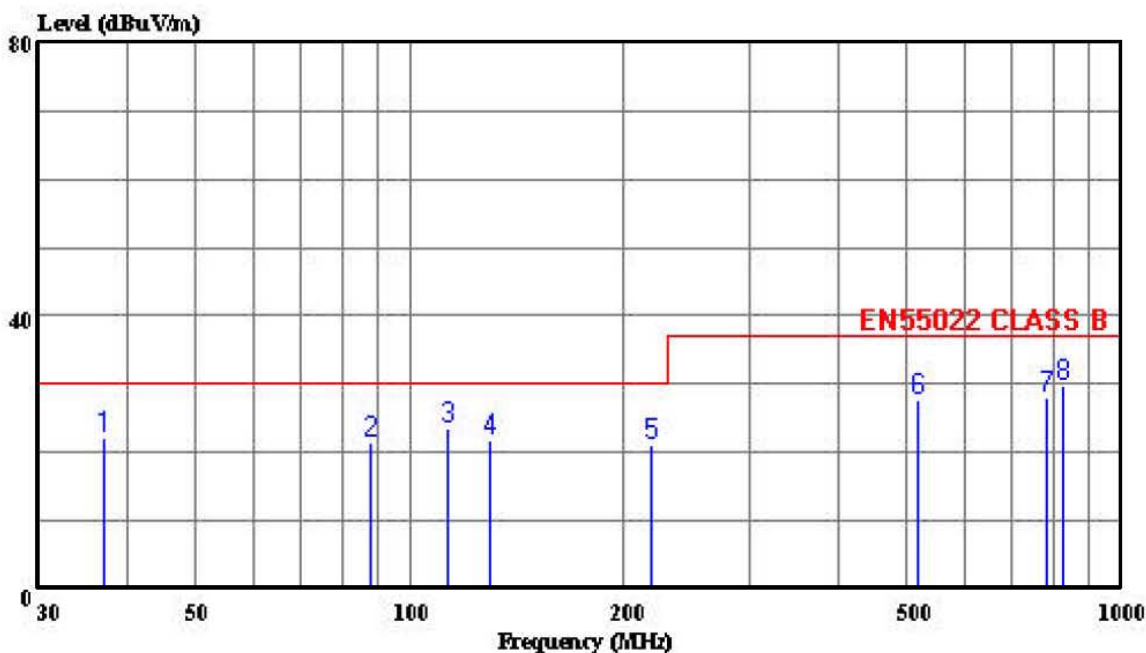

Trace:

Ref Trace:

Condition: EN55022 CLASS B 10m CHASE 2614 060506 VERTICAL
eut : Video Interference Blocker
power: 230V/50Hz
memo : CHB001T

Page: 1

	Freq	Level	Limit	Over	ReadAntenna	Cable	Preamp	Remark
	MHz	dBuV/m	dBuV/m	dB	dBuV	dB/m	dB	dB
1	37.000	22.18	30.00	-7.82	31.70	15.62	0.82	25.96 Peak
2	88.000	21.31	30.00	-8.69	37.21	8.65	1.27	25.82 Peak
3	113.000	23.60	30.00	-6.40	35.73	12.18	1.45	25.76 Peak
4	129.313	21.90	30.00	-8.10	34.54	11.54	1.55	25.73 Peak
5	219.000	21.25	30.00	-8.75	35.63	9.17	2.06	25.60 Peak
6	515.680	27.67	37.00	-9.33	31.42	17.76	3.39	24.91 Peak
7	782.033	27.99	37.00	-9.01	27.87	19.70	4.26	23.84 Peak
8	827.687	29.61	37.00	-7.39	28.79	20.04	4.51	23.72 Peak

HARMONICS TEST

1 TEST INSTRUMENTS & FACILITIES

Instruments/ facilities	Manufacturer	Model # Serial #	Date of Cal.
HARMONICS/ VOLTAGE FLUCTUATIONS TEST	EMC-PARTNER	HAR1000-1P	OCT/2004
CONTROL PC	KB TECH	KB P586/133	N/A

Note : Item 1 were calibrated with two years and verified before testing.

2 TEST PROCEDURE

According to **EN 61000-3-2 (2000) Class A**

3 TEST SETUP

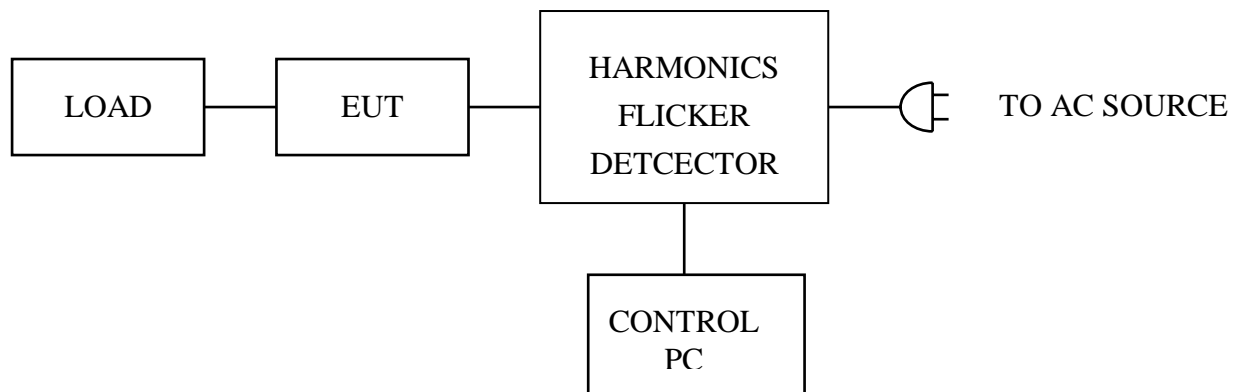

(Details for setup configuration, please refer to appendix A.)

4 CONFIGURATION OF THE EUT

Same as “Conducted Power Line test”, section 4

5 OPERATION CONDITION OF EUT

Same as “Conducted Power Line test”, section 5

6 TEST DATA & LIMIT

6.1 Temperature : 24 °C

6.2 Humidity : 55 % RH

7 Photos of test configuration please refer to appendix A.



8 HARMONICS TEST DATA (PAGE 1~2)

EMC PARTNER AG, SWITZERLAND

Date : 2006/6/26 PM 16:16:4 V4.14

Operator : CHAD
 Unit : Video Interference Blocker
 Serialnumber : CHB001T
 Remarks : 5F011

Urms = 229.9V Freq = 49.987 Range: 0.25 A
 Irms = 0.046A Ipk = 0.108A cf = 2.361
 P = 3.718W S = 10.50VA pf = 0.354
 THDi = 50.0 % THDu = 0.10 % Class A

Test - Time : 15min (100 %)

Test completed, Result: PASSED

Order	Freq. [Hz]	Imax [A]	Imax%L [%]	Limit [A]	Status
1	50	0.0397			
2	100	0.0007	0.0636	1.0800	
3	150	0.0192	0.8333	2.3000	
4	200	0.0005	0.1065	0.4300	
5	250	0.0117	1.0226	1.1400	
6	300	0.0002	0.0712	0.3000	
7	350	0.0030	0.3844	0.7700	
8	400	0.0001	0.0464	0.2300	
9	450	0.0036	0.9117	0.4000	
10	500	0.0000	0.0000	0.1840	
11	550	0.0003	0.0786	0.3300	
12	600	0.0000	0.0100	0.1533	
13	650	0.0003	0.1453	0.2100	
14	700	0.0000	0.0116	0.1314	
15	750	0.0001	0.0509	0.1500	
16	800	0.0000	0.0133	0.1150	
17	850	0.0004	0.2998	0.1324	
18	900	0.0000	0.0000	0.1022	
19	950	0.0001	0.1160	0.1184	
20	1000	0.0000	0.0000	0.0920	
21	1050	0.0001	0.1282	0.1071	
22	1100	0.0000	0.0000	0.0836	
23	1150	0.0001	0.0780	0.0978	
24	1200	0.0000	0.0000	0.0767	



HomeTek Technology Inc.

25	1250	0.0001	0.1356	0.0900
26	1300	0.0000	0.0000	0.0708
27	1350	0.0001	0.0916	0.0833
28	1400	0.0000	0.0000	0.0657
29	1450	0.0001	0.0983	0.0776
30	1500	0.0000	0.0000	0.0613
31	1550	0.0000	0.0631	0.0726
32	1600	0.0000	0.0000	0.0575
33	1650	0.0000	0.0671	0.0682
34	1700	0.0000	0.0000	0.0541
35	1750	0.0001	0.0949	0.0643
36	1800	0.0000	0.0000	0.0511
37	1850	0.0000	0.0753	0.0608
38	1900	0.0000	0.0000	0.0484
39	1950	0.0000	0.0529	0.0577
40	2000	0.0000	0.0000	0.0460

Important:

- without "1000-4-7 Ed. 2" (DFT-window is 16 periods)

VOLTAGE FLUCTUATIONS TEST

1 TEST INSTRUMENTS & FACILITIES

Instruments/ facilities	Manufacturer	Model # Serial #	Date of Cal.
HARMONICS/ VOLTAGE FLUCTUATIONS TEST	EMC-PARTNER	HAR1000-1P	OCT/2004
CONTROL PC	KB TECH	KB P586/133	N/A

Note : Item 1 were calibrated with two years and verified before testing.

2 TEST PROCEDURE

According to **EN 61000-3-3 (1995) + A1 (2001)**

3 TEST SETUP

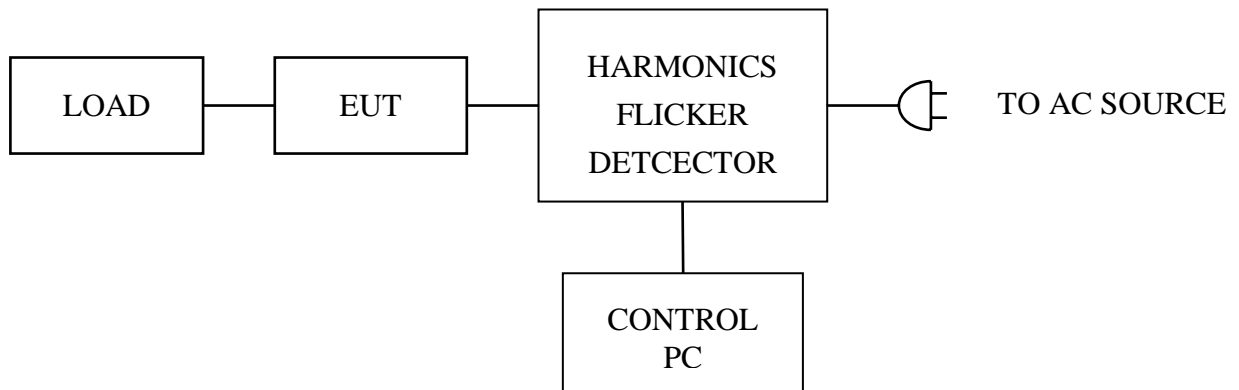

(Details for setup configuration, please refer to appendix A.)

4 CONFIGURATION OF THE EUT

Same as “Conducted Power Line test”, section 4

5 OPERATION CONDITION OF EUT

Same as “Conducted Power Line test”, section 5

6 TEST DATA & LIMIT

6.1 Temperature : 24 °C

6.2 Humidity : 55 % RH

7 Photos of test configuration please refer to appendix A.



8 VOLTAGE FLUCTUATIONS TEST DATA (PAGE 1)

EMC PARTNER AG, SWITZERLAND

Date : 2006/6/26 PM 16:27:4 V4.14

Operator : CHAD
 Unit : Video Interference Blocker
 Serialnumber : CHB001T
 Remarks : 5F011

Urms = 229.9V Freq = 50.000 Range: 0.25 A
 Irms = 0.046A Ipk = 0.108A cf = 2.349
 P = 3.780W S = 10.52VA pf = 0.359

Test - Time : 1 x 15min = 15min(100 %)

LIN (Line Impedance Network) : L: 0.24ohm +j0.15ohm N: 0.16ohm +j0.10ohm

Limits : Plt : 0.65 Pst : 1.00
 dmax : 4.00 % dc : 3.30 %
 dtLim: 3.30 % dt>Lim: 500ms

Test completed, Result: PASSED

Plt = 0.072

Pst dmax
 [%]
 1 0.072 0.000

4 CONFIGURATION OF THE EUT

Same as “Conducted Power Line test”, section 4

5 EUT OPERATION CONDITION

Same as “Conducted Power Line test”, section 5

6 TEST CONDITION

6.1 Test Level :

(A) $\pm 2, 4, 8$ KV for air discharge.

(B) $\pm 2, 4$ KV for contact discharge.

6.2 Number of test : 10 Discharges / Test point / Polarity / Level

Particular requirements : at least 200 discharges, 100 each at negative and positive polarity, at a minimum of four test points.

6.3 Time between test : 1 sec.

6.4 Temperature : 23 °C

6.5 Humidity : 50 % RH.

7 PERFORMANCE CRITERIA

- A. The apparatus shall continue to operate as intended during and after the test. No degradation of performance or loss of function is allowed below a performance level specified by the manufacturer, when the apparatus is used as intended.
- B. The apparatus shall continue to operate as intended after the test. No degradation of performance or loss of function is allowed below a performance level specified by the manufacturer, when the apparatus is used as intended. The performance level may be replaced by a permissible loss of performance. During the test, degradation of performance is however allowed.
- C. Temporary loss of function is allowed, provided the function is self-recoverable or can be restored by the operation of the controls.

8 TEST RESULT

Test Point	Air Discharge	Contact Discharge	Performance Criteria	Result
HCP	---	$\pm 2, 4KV$	A	PASSED
VCP	---	$\pm 2, 4KV$	A	PASSED
CASE	$\pm 2, 4, 8KV$	$\pm 2, 4KV$	A	PASSED
I/O PORTS	$\pm 2, 4, 8KV$	$\pm 2, 4KV$	A	PASSED
LED	$\pm 2, 4, 8KV$	$\pm 2, 4KV$	A	PASSED
AC SOCKET	$\pm 2, 4, 8KV$	$\pm 2, 4KV$	A	PASSED

9 Photos of test configuration please refer to appendix A.

RADIO FREQUENCY ELECTROMAGNETIC FIELD IMMUNITY TEST (RS)

1 TEST INSTRUMENTS & FACILITIES

Item	Instruments Facilities	Manufacturer	Model # Serial #	Data Of Cal.
1	SIGNAL GENERATOR	ROHDE & SCHWARZ	SMY02 845181/025	MAR/2006
2	AMPLIFIER	AMPLIFIER RESEARCH	100W1000M1A	N/A
3	FIELD SENSOR	AMPLIFIER RESEARCH	FP2000	AUG/2004
4	FIELD MONITOR	AMPLIFIER RESEARCH	FM2000	AUG/2004
5	RF VOLTMETER	BOONTON	9200C 361701AA	MAR/2006
6	RF PROBE	BOONTON	952001B 37082	MAR/2006
7	DIRECTION COUPLER	AMPLIFIER RESEARCH	DC6180 20521	N/A
8	ANTENNA	EMCO	3142B S/N: 1789	N/A
9	CONTROL PC	KB TECH	KB P586/133	--

Note : Items 3 ~ 4 were calibrated with two years and verified before testing.

2 TEST PROCEDURE

According to **IEC 61000-4-3 (2002)**

According to **EN 55024 (1998) + A1 (2001) + A2 (2003)**

3 TEST SETUP

FERRITE TILE

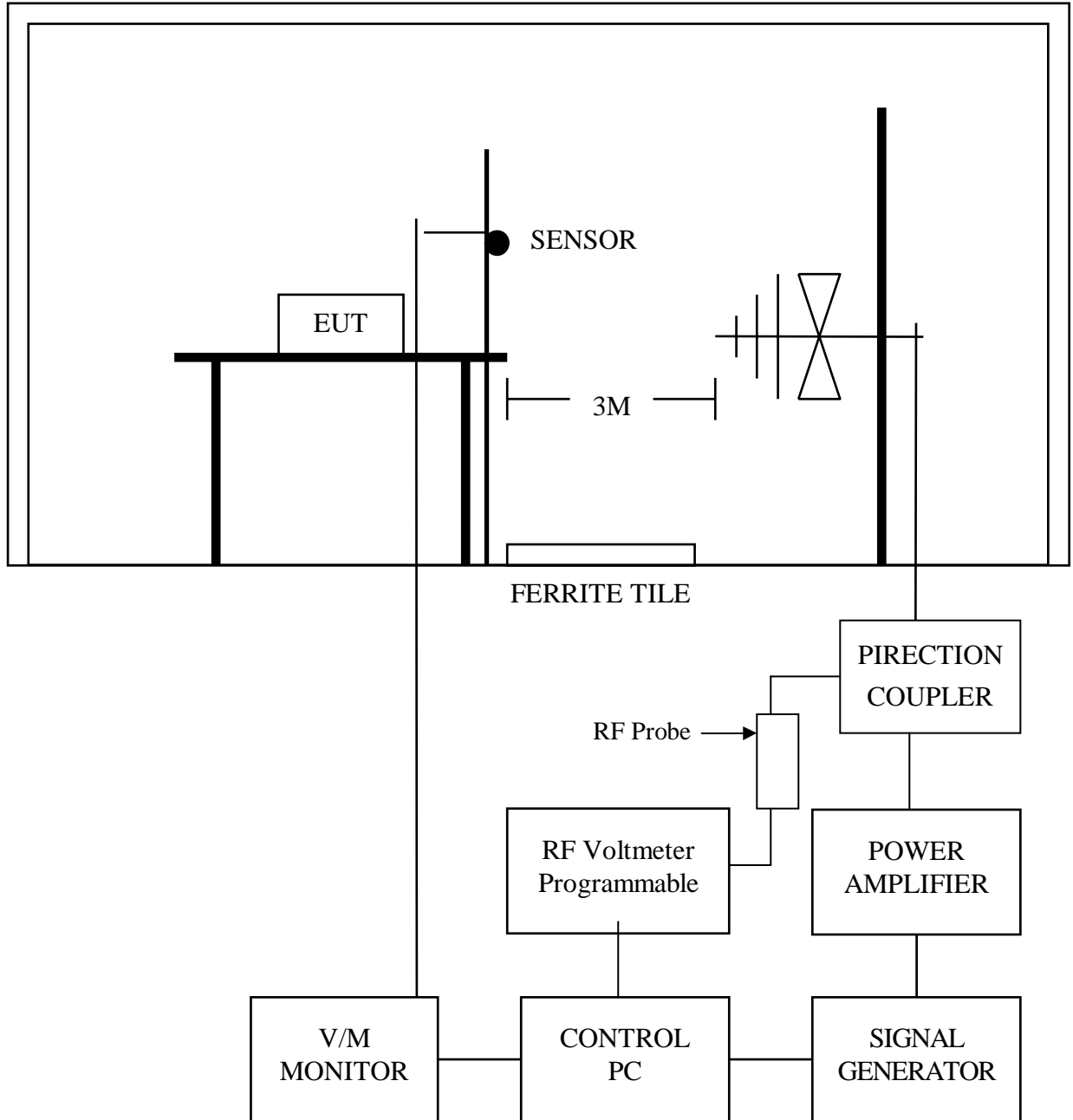

3.1 Chamber Size :

12M x 5M x 5M

(Details for setup configuration, please refer to appendix A.)

4 CONFIGURATION OF THE EUT

Same as “Conducted Power Line test”, section 4

5 OPERATION CONDITION OF EUT

Same as “Conducted Power Line test”, section 5

6 TEST CONDITION

6.1 Frequency Range : 80 MHz ~ 1000 MHz

(Frequency Range : 1.4 GHz ~ 2.0 GHz is not applicable for EN55024:1998+A1:2001+A2:2003)

6.2 Field Strength : 3 V / M (1KHz 80% Modulation)

6.3 Frequency Step : 1 %, 3 sec. / each step size

6.4 Antenna Polarity : HORIZONTAL & VERTICAL

6.5 The four sides of EUT are tested
(FRONT, REAR, RIGHT, LEFT)

6.6 Temperature : 26 °C

6.7 Humidity : 55 % RH

7 PERFORMANCE CRITERIA

- A. The apparatus shall continue to operate as intended during and after the test. No degradation of performance or loss of function is allowed below a performance level specified by the manufacturer, when the apparatus is used as intended.
- B. The apparatus shall continue to operate as intended after the test. No degradation of performance or loss of function is allowed below a performance level specified by the manufacturer, when the apparatus is used as intended. The performance level may be replaced by a permissible loss of performance. During the test, degradation of performance is however allowed.
- C. Temporary loss of function is allowed, provided the function is self-recoverable or can be restored by the operation of the controls.

8 TEST RESULT

ANT SIDE	HORIZONTAL	VERTICAL	RESULT
FRONT	A	A	PASSED
REAR	A	A	PASSED
RIGHT	A	A	PASSED
LEFT	A	A	PASSED

9 Photos of test configuration please refer to appendix A.

ELECTRICAL FAST TRANSIENT/BURST IMMUNITY TEST (EFT)

1 TEST INSTRUMENTS & FACILITIES

Instruments/ Facilities	Manufacturer	Model # Serial #	Data Of Cal.
BURST-TESTER	HAEFELY	PEFT/JUNIOR	FEB/2006
CONTROL PC	KB TECH	KB P586/133	--

2 TEST PROCEDURE

According to **IEC 61000-4-4 (2004)**

According to **EN 55024 (1998) + A1 (2001) + A2 (2003)**

3 TEST SETUP

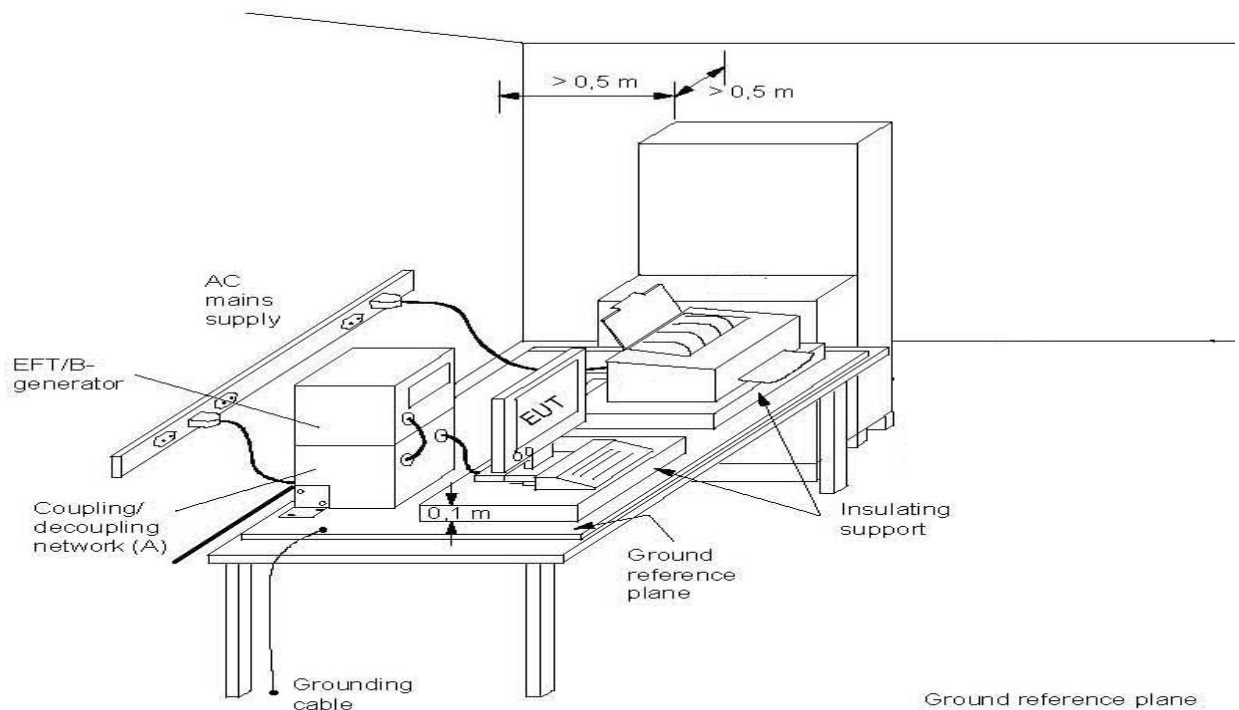

(Details for setup configuration, please refer to appendix A.)

Note: length between clamp and the EUT to be tested (should be $0.5\text{ m} \pm 0.05\text{ m}$)

(A) location for supply line coupling

(B) location for signal line coupling

4 CONFIGURATION OF THE EUT

Same as “Conducted Power Line test”, section 4

5 OPERATION CONDITION OF EUT

Same as “Conducted Power Line test”, section 5

6 TEST CONDITION

6.1 Pulse Rise time & Duration : 5 nS / 50 nS

6.2 Pulse Repetition : 5 kHz

6.3 Polarity : POSITIVE / NEGATIVE

6.4 Test Voltage of Power Line : $\pm 0.5\text{KV}$, $\pm 1\text{KV}$

6.5 Coupling of power line :
L, N, L+N

6.6 Temperature : 24 °C

6.7 Humidity : 55 % RH

7 PERFORMANCE CRITERIA

- A. The apparatus shall continue to operate as intended during and after the test. No degradation of performance or loss of function is allowed below a performance level specified by the manufacturer, when the apparatus is used as intended.
- B. The apparatus shall continue to operate as intended after the test. No degradation of performance or loss of function is allowed below a performance level specified by the manufacturer, when the apparatus is used as intended. The performance level may be replaced by a permissible loss of performance. During the test, degradation of performance is however allowed.
- C. Temporary loss of function is allowed, provided the function is self-recoverable or can be restored by the operation of the controls.

8 TEST RESULT

Power Line :

TEST VOLTAGE	L	N	L+N
±0.5KV	B	B	B
±1KV	B	B	B

※ The screen display snowflake, during the test. After the test, EUT resume automatically.

8.1 Model : CHB001T

8.2 Final Result : PASSED

8.3 Remark :

9 Photos of test configuration please refer to appendix A.

SURGE IMMUNITY TEST

1 TEST INSTRUMENTS & FACILITIES

Instruments/ Facilities	Manufacturer	Model # Serial #	Data Of Cal.
SURGER-TESTER	HAEFELY	PSURGE 4010 583334-38	FEB/2006
CONTROL PC	KB TECH	KB P586/133	--

2 TEST PROCEDURE

According To **IEC 61000-4-5 (2001)**

According To **EN 55024 (1998) + A1 (2001) + A2 (2003)**

3 TEST SETUP

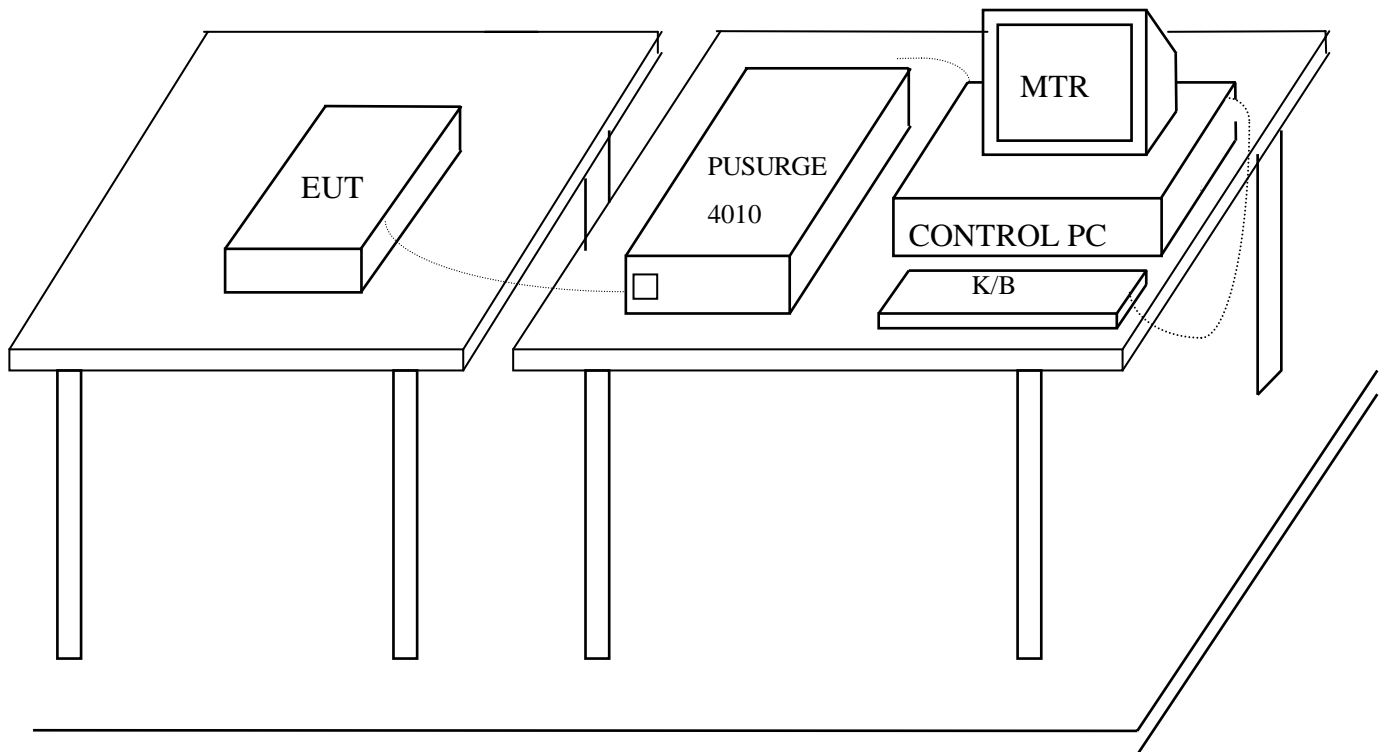

GROUND PLANE

(Details for setup configuration, please refer to appendix A.)

4 TEST LEVELS

- Input and Output AC Power Ports.
- DC Input and DC Output Power Ports.

Environmental Phenomena	Test Specification		Units	Performance Criteria
	AC	DC		
Surges	1.2 / 50 (8/20)		Tr /Th us	
Line to Line	±1	±0.5	KV (Charge Voltage)	B

5 CONFIGURATION OF THE EUT

Same as “Conducted Power Line test”, section 4

6 EUT OPERATION CONDITION

Same as “Conducted Power Line test”, section 5

7 CONDITIONS DURING TESTING

7.1 Coupling of power line :

(A) Line to Line ±1KV (AC) or ±0.5KV (DC)

7.2 Polarity : POSITIVE / NEGATIVE

7.3 Phase shifting in a range between 0° to 360°

7.4 Repletion rate at least 1 per min

7.5 Temperature : 24 °C (15°C ~ 35°C)

Humidity : 55 % RH.(10 % ~ 75%)

8 PERFORMANCE CRITERIA

- A. The apparatus shall continue to operate as intended during and after the test. No degradation of performance or loss of function is allowed below a performance level specified by the manufacturer, when the apparatus is used as intended.
- B. The apparatus shall continue to operate as intended after the test. No degradation of performance or loss of function is allowed below a performance level specified by the manufacturer, when the apparatus is used as intended. The performance level may be replaced by a permissible loss of performance. During the test, degradation of performance is however allowed.
- C. Temporary loss of function is allowed, provided the function is self-recoverable or can be restored by the operation of the controls.

9 TEST RESULT

Environmental Phenomena	Test Specification	Units	Performance
Line to Line	±1	KV (Charge Voltage)	A

9.1 Model : CHB001T

9.2 Final Result : PASSED

9.3 Remark :

10 Photos of test configuration please refer to appendix A.

IMMUNITY TEST TO CS CONDUCTED DISTURBANCE

1 TEST INSTRUMENTS & FACILITIES

Instruments/ Facilities	Manufacturer	Model # Serial #	Date Of Cal.
SIGNAL GENERATOR	ROHDE & SCHWARZ	SMY02 845181/025	MAR/2006
AMPLIFIER	AMPLIFIER RESEARCH	75A250 25680	N/A
RF VOLTMETER	BOONTON	9200C 361701AA	MAR/2006
RF PROBE	BOONTON	952001B 37082	MAR/2006
DIRECTION COUPLER	AMPLIFIER RESEARCH	DC2600 20508	N/A
COUPLING DECOUPLING NETWORK	FCC	FCC-801-M3-25A 9993	MAR/2006
CONTROL PC	KB TECH	KB P586/133	--

2 TEST PROCEDURE

According To **IEC 61000-4-6 (2003) + A1 (2004)**

According To **EN 55024 (1998) + A1 (2001) + A2 (2003)**

3 TEST SETUP

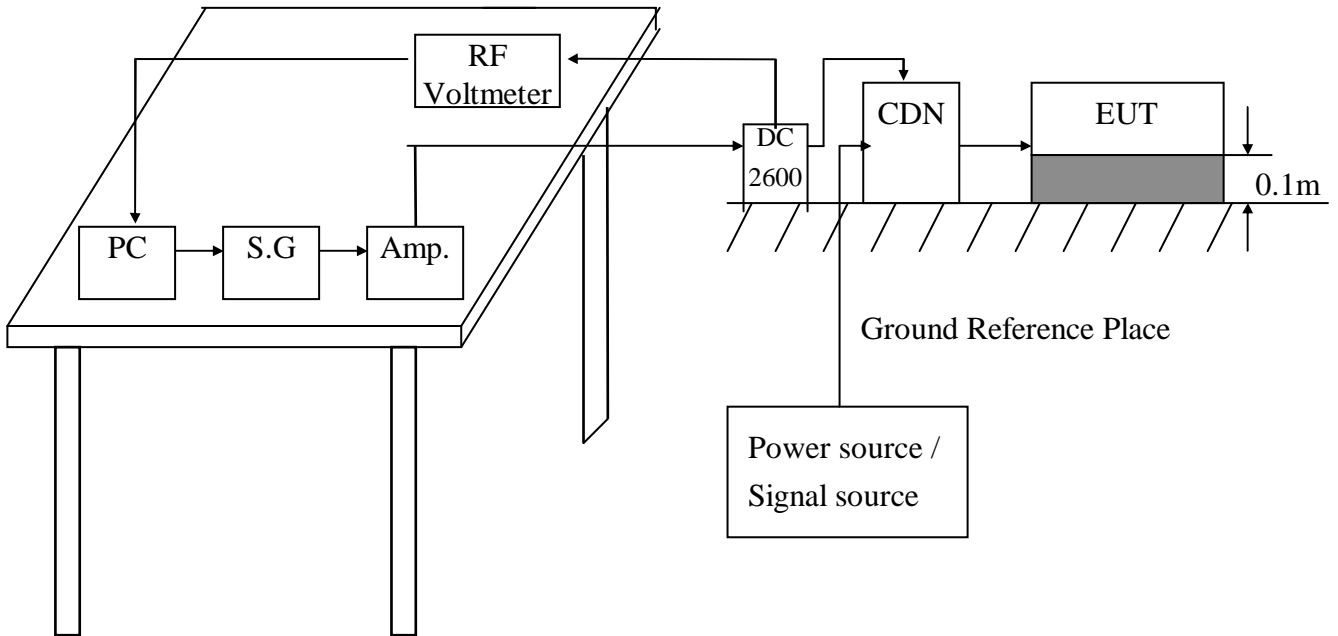

(Details for setup configuration, please refer to appendix A.)

4 TEST LEVELS

- Ports for signal lines and control lines.
- DC input and DC output power ports.
- Input and Output AC Power Ports.
- Functional earth Ports.

Environmental	Test Specification	Units	Performance
Radio-frequency	0.15 - 80	MHz	
Common mode	3	V	A
	80	% AM (1KHz)	

5 CONFIGURATION OF THE EUT

Same as “Conducted Power Line test”, section 4

6 EUT OPERATION CONDITION

Same as “Conducted Power Line test”, section 5

7 CONDITIONS DURING TESTING

7.1 The EUT tested type :

- Single unit
- Multiple unit

7.2 Dwell time : < 1%

7.3 Temperature : 24 °C (15°C ~ 35°C)

Humidity : 55 % RH.(10 % ~ 75%)

8 PERFORMANCE CRITERIA

- A. The apparatus shall continue to operate as intended during and after the test. No degradation of performance or loss of function is allowed below a performance level specified by the manufacturer, when the apparatus is used as intended.
- B. The apparatus shall continue to operate as intended after the test. No degradation of performance or loss of function is allowed below a performance level specified by the manufacturer, when the apparatus is used as intended. The performance level may be replaced by a permissible loss of performance. During the test, degradation of performance is however allowed.
- C. Temporary loss of function is allowed, provided the function is self-recoverable or can be restored by the operation of the controls.

9 TEST RESULT

TEST Specification	Unit	Performance Criteria
0.15 - 80	MHz	A
3	V	
80	% AM (1KHz)	

9.1 Model : CHB001T

9.2 Final Result : PASSED

9.3 Remark :

10 Photos of test configuration please refer to appendix A.

POWER FREQUENCY MAGNETIC FIELD IMMUNITY TEST

1 TEST INSTRUMENTS & FACILITIES

Instruments/ Facilities	Manufacturer	Model # Serial #	Data Of Cal.
LINE INTERFERENCE TESTER	HAEFELY	PLINE 1610 080166-10	MAR/2006
MAGNETIC FIELD TESTER	HAEFELY	MAG 100.1 080206-01	N/A
TRIAXIAL ELF MAGNETIC FIELD METER	F.W.BELL	4080 9645	JUL/2005
CONTROL PC	KB TECH	KB P586/133	--

2 TEST STANDARD

According To **IEC 61000-4-8 (2001)**

According To **EN 55024 (1998) + A1 (2001) + A2 (2003)**

3 TEST SETUP

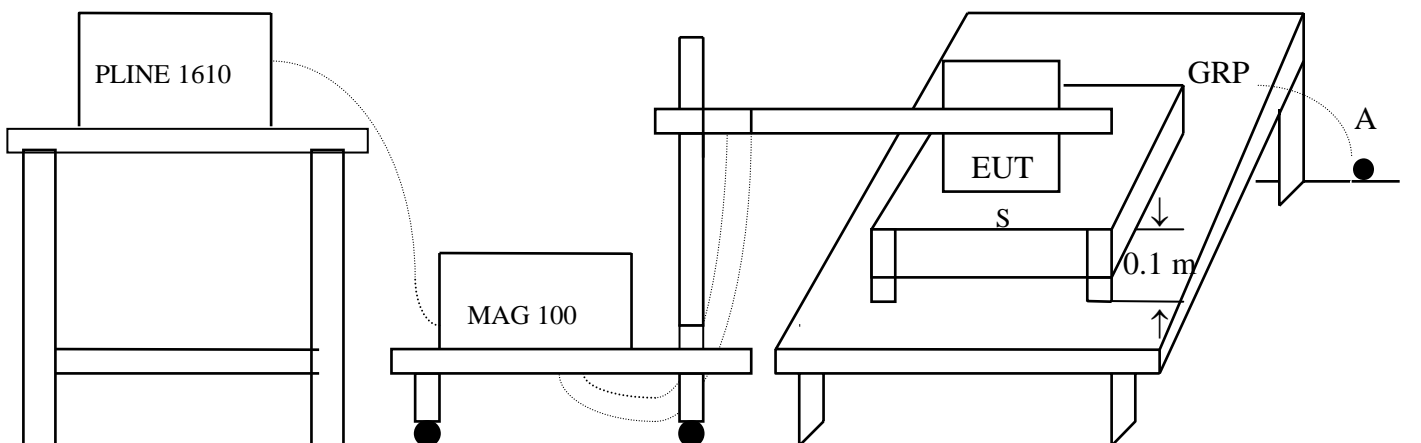

S: Insulating support

A: Safety earth

GRP: Ground plane

(Details for setup configuration, please refer to appendix A.)

4 TEST LEVELS

Environmental Phenomena	Test Specification	Units	Performance Criteria
Power Frequency	50	HZ	
Magnetic Field	1	A/m	B

5 CONFIGURATION OF THE EUT

Same as “Conducted Power Line test”, section 4

6 OPERATION CONDITION OF EUT

Same as “Conducted Power Line test”, section 5

7 CONDITIONS DURING TESTING

7.1 Temperature : 24 °C (15°C ~ 35°C)

Humidity : 55 % RH.(25 % ~ 75%)

7.2 The induction coil shall be rotated by 90°

8 PERFORMANCE CRITERIA

- A. The apparatus shall continue to operate as intended during and after the test. No degradation of performance or loss of function is allowed below a performance level specified by the manufacturer, when the apparatus is used as intended.
- B. The apparatus shall continue to operate as intended after the test. No degradation of performance or loss of function is allowed below a performance level specified by the manufacturer, when the apparatus is used as intended. The performance level may be replaced by a permissible loss of performance. During the test, degradation of performance is however allowed.
- C. Temporary loss of function is allowed, provided the function is self-recoverable or can be restored by the operation of the controls.

9 TEST RESULTS

Environmental Phenomena	Test Specification	Units	Performance Criteria
Magnetic Field	1	A/m	A

9.1 Model : CHB001T

9.2 Final Results : PASSED

9.3 Remark :

10 Photos of test configuration please refer to appendix A.

VOLTAGE DIPS, SHORT INTERRUPTIONS IMMUNITY TEST

1 TEST INSTRUMENTS & FACILITIES

Instruments/ Facilities	Manufacturer	Model # Serial #	Data Of Cal.
LINE INTERFERENCE -TESTER	HAEFELY	PLINE 1610 080166-10	MAR/2006
CONTROL PC	KB TECH	KB P586/133	--

2 TEST PROCEDURE

According To **IEC 61000-4-11 (2004)**

According To **EN 55024 (1998) + A1 (2001) + A2 (2003)**

3 TEST SETUP

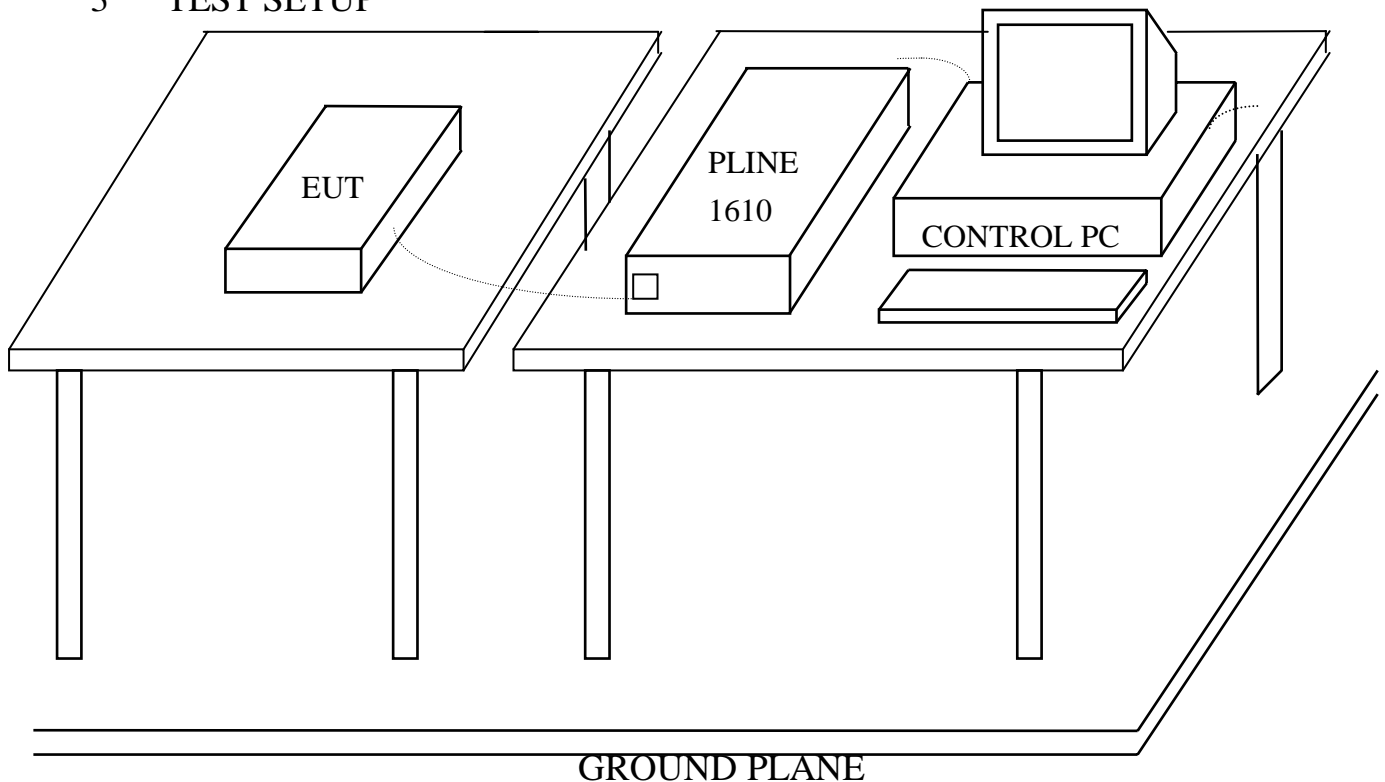

(Details for setup configuration, please refer to appendix A.)

4 TEST LEVELS

Input and Output AC Power Ports.

- Voltage Dips.
- Voltage Interruptions.

Class ^a	Test level and durations for voltage dips				
Class 1	Case-by-case according to the equipment requirements				
Class 2	0 % during 1/2 cycle	0 % during 1 cycle	70 % during 25/30 ^c cycles		
Class 3	0 % during 1/2 cycle	0 % during 1 cycle	40 % during 10/12 ^c cycles	70 % during 25/30 ^c cycles	80 % during 250/300 ^c cycles
a: Classes as per IEC 61000-2-4. b: To be defined by product committee. For equipment connected directly or indirectly to the public network, the levels must not be less severe than Class 2. c: “25/30 cycles” means “25 cycles for 50 Hz test” and “30 cycles for 60 Hz tet”.					

Class ^a	Test level and durations for short interruptions (t _s) (50Hz / 60Hz)
Class 1	Case-by-case according to the equipment requirements
Class 2	0 % during 250/300 ^c cycles
Class 3	0 % during 250/300 ^c cycles
Class X ^b	X
a: Classes as per IEC 61000-2-4. b: To be defined by product committee. For equipment connected directly or indirectly to the public network, the levels must not be less severe than Class 2. c: “250/300 cycles” means “250 cycles for 50 Hz test” and “300 cycles for 60 Hz test”.	

✘ **According to the specification of EUT, Class 2 is applied.**

5 CONFIGURATION OF THE EUT

Same as “Conducted Power Line test”, section 4

6 EUT OPERATION CONDITION

Same as “Conducted Power Line test”, section 5

7 CONDITIONS DURING TESTING

- 7.1 Temperature : 24 °C (15°C ~ 35°C)
 Humidity : 55 % RH.(25 % ~ 75%)

8 PERFORMANCE CRITERIA

- A. The apparatus shall continue to operate as intended during and after the test. No degradation of performance or loss of function is allowed below a performance level specified by the manufacturer, when the apparatus is used as intended.
- B. The apparatus shall continue to operate as intended after the test. No degradation of performance or loss of function is allowed below a performance level specified by the manufacturer, when the apparatus is used as intended. The performance level may be replaced by a permissible loss of performance. During the test, degradation of performance is however allowed.
- C. Temporary loss of function is allowed, provided the function is self-recoverable or can be restored by the operation of the controls.

9 TEST RESULT

Environmental Phenomena	Test Specification	Units	Perform Criteria
Voltage Dips	0 1/2	% during Cycle	A
	0 1	% during Cycle	C
	70 25	% during Cycles	C
Voltage Short Interruptions	0	% during	C
	250	Cycles	

9.1 Model : CHB001T

9.2 Final Results : PASSED

9.3 Remark :

10 Photos of test configuration please refer to appendix A.



HomeTek Technology Inc.

Appendix A

PHOTOS OF TEST CONFIGURATION

PHOTO OF CONDUCTED POWER LINE TEST

Model : CHB001T



Front View



Rear View

PHOTO OF RADIATED EMISSION TEST

Model : CHB001T



Front View

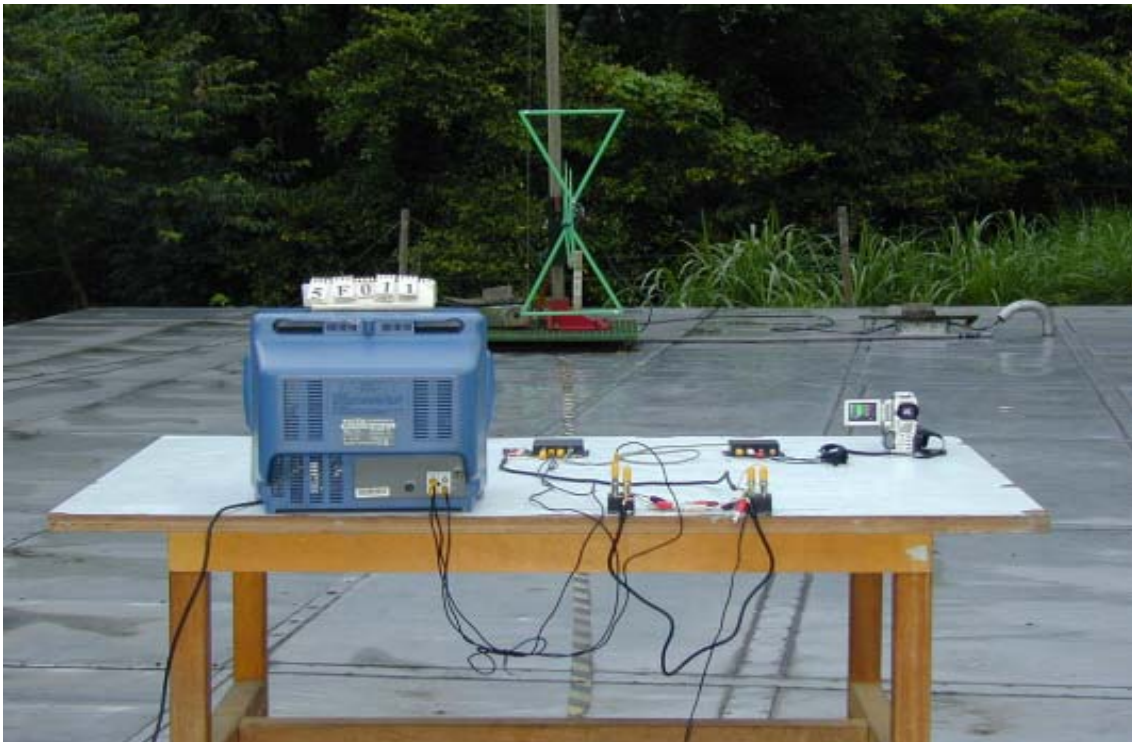

Rear View

**PHOTO OF HARMONICS & VOLTAGE FLUCTUATIONS TEST
AND SURGE IMMUNITY TEST AND VOLTAGE DIPS, SHORT
INTERRUPTIONS IMMUNITY TEST**

Model : CHB001T



**PHOTO OF ELECTRICAL FAST TRANSIENT/BURST IMMUNITY
TEST**



PHOTO OF ELECTROSTATIC DISCHARGE IMMUNITY TEST (ESD)

Model : CHB001T



PHOTO OF POWER FREQUENCY MAGNETIC FIELD IMMUNITY TEST



PHOTO OF RADIO FREQUENCY ELECTROMAGNETIC FIELD IMMUNITY TEST (RS)

Model : CHB001T



PHOTO OF CS CONDUCTED DISTURBANCE IMMUNITY TEST





HomeTek Technology Inc.

Appendix B

PHOTOS OF EUT

PHOTO OF EUT

Model : CHB001T

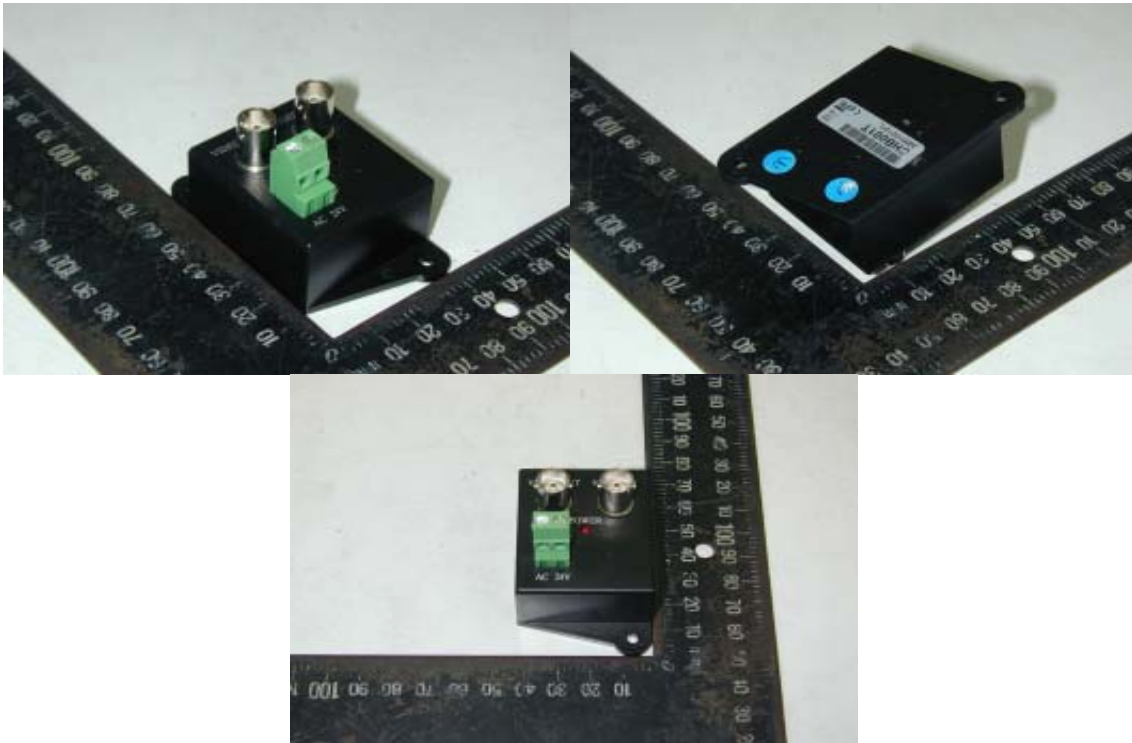

Full View of EUT

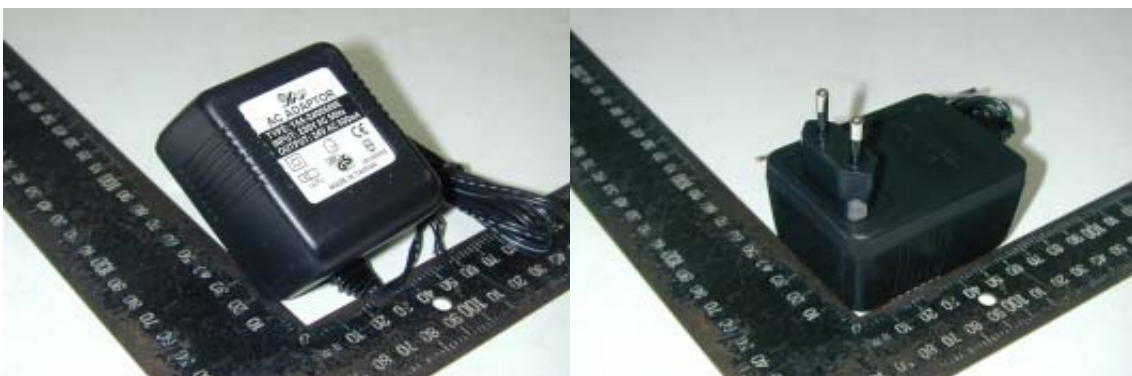

Full View of Adaptor

Declaration of Conformity

We(Manufacturer/Importer)

(company name)

(address)

declares under our sole responsibility that the product

Product name : Video Interference Blocker

Model No. : CHB00XXXT

to which this declaration relates is in conformity with the following standard(s) or other normative document(s)

- | | |
|---|---|
| <input checked="" type="checkbox"/> EN 55022 Class B (1998) | <input checked="" type="checkbox"/> EN 55024 (1998) |
| + A1 (2000) | + A1 (2001) |
| + A2 (2003) | + A2 (2003) |
| <input checked="" type="checkbox"/> EN 61000-3-2 (2000) | <input checked="" type="checkbox"/> IEC 61000-4-2 (2001) |
| <input checked="" type="checkbox"/> EN 61000-3-3 (1995) | <input checked="" type="checkbox"/> IEC 61000-4-3 (2002) |
| + A1 (2001) | <input checked="" type="checkbox"/> IEC 61000-4-4 (2004) |
| | <input checked="" type="checkbox"/> IEC 61000-4-5 (2001) |
| | <input checked="" type="checkbox"/> IEC 61000-4-6 (2003) |
| | + A1 (2004) |
| | <input checked="" type="checkbox"/> IEC 61000-4-8 (2001) |
| | <input checked="" type="checkbox"/> IEC 61000-4-11 (2004) |

following the provisions of 89/336/EEC Directive

Place: _____ Signature: _____

Date : _____ Full name: _____



Title: _____



TÜV Rheinland Taiwan Ltd.

Certificate

of

Appointment

for the applicant:

Hometek Technology Inc.
No. 67-9, Shir Men Rd., Tu-Cheng City,
Taipei Hsien 236, Taiwan, R.O.C.

has been authorized to carry out EMC tests by order and under supervision of TÜV Rheinland. It has successfully demonstrated capability to conduct measurement and to process test data according to:

**European and International EMC Standards as listed in the
Scope of Authorization on the attachment to this certificate**

An assessment of the facility was conducted by TÜV Rheinland auditors according to the TÜV Rheinland requirements for "Test Site Approval" with reference to

ISO 17 025:1999

Certificate No. : 10012161-2006

Valid until : June 14, 2007

TÜV Rheinland Taiwan Ltd.
Taipei, April 13, 2006

Dipl.-Ing. Andreas Klinker
Certification Body

Dipl.-Ing. Bodo Kretzschmar
Product Safety and Quality



Attachment to
Certificate
of Appointment

SCOPE OF AUTHORIZATION

Hometek Technology Inc.
No. 67-9, Shir Men Rd., Tu-Cheng City,
Taipei Hsien 236, Taiwan, R.O.C.

European Standards

EN 50081-1	EN 61000-3-2	ENV 50140
EN 50081-2	EN 61000-3-3	ENV 50141
EN 50082-1	EN 61000-6-1	ENV 50204
EN 50130-4	EN 61000-6-2	
EN 50091-2	EN 61000-6-3	
EN 55011	EN 61000-6-4	
EN 55013	EN 61000-3-11	
EN 55014-1	EN 61000-4-2	
EN 55014-2	EN 61000-4-3	
EN 55022	EN 61000-4-4	
EN 55024	EN 61000-4-5	
EN 60601-1-2	EN 61000-4-6	
EN 60801	EN 61000-4-8	
EN 60945	EN 61000-4-11	
	EN 61204-3	

International Standards

CISPR 11	IEC 61000-4-2	IEC 61000-3-2
CISPR 13	IEC 61000-4-3	IEC 61000-3-3
CISPR 14-1	IEC 61000-4-4	IEC 61000-3-11
CISPR 14-2	IEC 61000-4-5	IEC 61000-6-1
CISPR 22	IEC 61000-4-6	IEC 61000-6-2
CISPR 24	IEC 61000-4-8	IEC 61000-6-3
	IEC 61000-4-11	IEC 61000-6-4
IEC 801.2	IEC 61000-4-12	IEC 60945
IEC 801.3		
IEC 801.4		

Certificate No. : 10012161-2006

Taipei, April 13, 2006

Dipl.-Ing. Bodo Kretzschmar
Product Safety and Quality