



HomeTek Technology Inc.

ADDRESS: No. 67-9, Shir Men Road, Tu Cheng City,  
Taipei Hsien, Taiwan, R. O. C.

PHONE : 886-2-22608375 FAX : 886-2-22748013

E - mail : hometek@ms15.hinet.net

## CERTIFICATE OF COMPLIANCE

EUT : Video Ground Loop Isolator  
MODEL NO. : GL00X, GB00X (X = 1~9)  
Receipt Date : 08/10/2004 Final Test Date: 08/12/2004  
REPORT # : EB3H007  
APPLICANT : SMART CABLING & TRANSMISSION CORP.  
ADDRESS : 7F-1, No. 168, Lien Cheng Rd.,  
Chung-Ho City, Taipei Hsien, Taiwan, R. O. C.

Measurement procedure used:

**EMI: EN 61000-6-3 (2001): CISPR 22 Class B (1997),**

**EN 61000-3-2 (2000), EN 61000-3-3 (1995) + A1 (2001)**

**EMS: EN 50130-4 (1996) + A1 (1998):**

**IEC 61000-4-2 (1995) + A1 (1998), IEC 61000-4-3 (1995) + A1 (1998),**

**IEC 61000-4-4 (1995), IEC 61000-4-5 (1995), ENV 50141 (1993), IEC 61000-4-11 (1994)**

We hereby show that:

The measurements shown in this test report were made in accordance with the procedures given in **EUROPEAN COUNCIL DIRECTIVE 89/336/EEC**, and the energy emitted by the equipment was found to be within the limits applicable.

This test result of this report applies to above tested sample only.

This test report shall not be reproduce in part without written approval of HomeTek Technology Inc.

PREPARED BY : Frankie DATE : 8/17/2004  
FRANKIE WANG

CHECK BY : Albert Tsai DATE : 8/17/2004  
ALBERT TSAI / Senior Engineer

APPROVED BY : Tommy Rau DATE : 8/17/2004  
TOMMY RAU / Manager



**TABLE OF CONTENTS .....1**

**GENERAL INFORMATION.....3**

**MODIFICATION LIST.....5**

**CONDUCTED POWER LINE TEST.....6**

1 TEST PROCEDURE.....6

2 RESULT OF CONDUCTED EMISSION TEST.....6

**RADIATED EMISSION TEST.....7**

1 TEST INSTRUMENTS & FACILITIES .....7

2 TEST PROCEDURE.....8

3 TEST SETUP .....8

4 CONFIGURATION OF THE EUT.....9

5 EUT OPERATING CONDITION.....12

6 LIMIT OF RADIATED EMISSION CLASS B.....12

7 RESULT OF RADIATED EMISSION TEST.....12

**HARMONICS TEST .....13**

1 TEST PROCEDURE.....13

2 RESULT OF HARMONICS TEST.....13

**VOLTAGE FLUCTUATIONS TEST.....14**

1 TEST PROCEDURE.....14

2 RESULT OF VOLTAGE FLUCTUATIONS TEST .....14

**ELECTROSTATIC DISCHARGE IMMUNITY TEST (ESD).....15**

1 TEST INSTRUMENTS & FACILITIES .....15

2 TEST PROCEDURE.....15

3 TEST SETUP .....15

4 CONFIGURATION OF THE EUT.....16

5 EUT OPERATION CONDITION.....16

6 TEST CONDITION .....16

7 PERFORMANCE CRITERIA .....16

8 TEST RESULT.....17

**RADIO FREQUENCY ELECTROMAGNETIC FIELD IMMUNITY TEST (RF).....18**

1 TEST INSTRUMENTS & FACILITIES.....18

2 TEST PROCEDURE.....18

3 TEST SETUP .....19

4 CONFIGURATION OF THE EUT.....20

5 OPERATION CONDITION OF EUT .....20

6 TEST CONDITION .....20

7 PERFORMANCE CRITERIA .....20

8 TEST RESULT.....21



**ELECTRICAL FAST TRANSIENT/BURST IMMUNITY TEST (EFT) .....22**

1 TEST INSTRUMENTS & FACILITIES .....22

2 TEST PROCEDURE .....22

3 TEST SETUP .....22

4 CONFIGURATION OF THE EUT.....23

5 OPERATION CONDITION OF EUT .....23

6 TEST CONDITION .....23

7 PERFORMANCE CRITERIA .....23

8 TEST RESULT.....24

**SURGE IMMUNITY TEST.....25**

1 TEST PROCEDURE .....25

2 RESULT OF SURGE IMMUNITY TEST.....25

**IMMUNITY TEST TO CS CONDUCTED DISTURBANCE .....26**

1 TEST PROCEDURE.....26

2 RESULT OF IMMUNITY TEST TO CS CONDUCTED DISTURBANCE.....26

**VOLTAGE DIPS, SHORT INTERRUPTIONS IMMUNITY TEST .....27**

1 TEST PROCEDURE.....27

2 RESULT OF VOLTAGE DIPS, SHORT INTERRUPTIONS IMMUNITY TEST.....27

**APPENDIX A**

PHOTOS OF TEST CONFIGURATION

**APPENDIX B**

PHOTOS OF EUT

**GENERAL INFORMATION**

- 1 APPLICANT : SMART CABLING & TRANSMISSION CORP.
- 2 ADDRESS : 7F-1, No. 168, Lien Cheng Rd.,  
Chung-Ho City, Taipei Hsien, Taiwan, R. O. C.
- 3 MANUFACTURER : SMART CABLING & TRANSMISSION CORP.
- 4 ADDRESS : 7F-1, No. 168, Lien Cheng Rd.,  
Chung-Ho City, Taipei Hsien, Taiwan, R. O. C.
- 5 DESCRIPTION OF EUT :
- EUT : Video Ground Loop Isolator
- Model : GL00X, GB00X (X = 1~9)
- Serial # : N/A

- 5.1 The difference between models GL00X, GB00X (X = 1~9) are different color of case and GB00X with BALUN for signal transmission. The circuits of these models are same, and EMI characteristic is same. The worst case of EMC test data was shown in this test report.

6 FEATURES OF EUT :

|      |                               |                |       |
|------|-------------------------------|----------------|-------|
| 6.1  | Model No.                     | GL001          | GB001 |
| 6.2  | Insertion Loss                | 0.5dB          |       |
| 6.3  | Frequency Response            | 0-3dB at 10Mhz |       |
| 6.4  | Input Resistance              | 75ohm          |       |
| 6.5  | Output Resistance             | 75ohm          |       |
| 6.6  | Isolation Voltage             | 600VDC (Min)   |       |
| 6.7  | Insulation Resistance         | 100m ohm       |       |
| 6.8  | Transient Voltage Suppressors | 12Vrms         |       |
| 6.9  | BALUN                         | NO             | YES   |
| 6.10 | Material                      | ABS Black      |       |

- 7 As EUT is passive component inside only without AC or DC power input. Thus, some test items were not applicable to this EUT.



**MODIFICATION LIST**

THE FOLLOWING ACCESSORIES WERE ADDED TO THE EUT DURING TESTING :

NO MODIFICATION BY HOMETEK TECHNOLOGY INC.



## **CONDUCTED POWER LINE TEST**

### **1 TEST PROCEDURE**

According to **EN 61000-6-3**.

### **2 RESULT OF CONDUCTED EMISSION TEST**

N/A (Conducted Power Line Test is not applicable to this EUT ( Model : GB001)).

## RADIATED EMISSION TEST

### 1 TEST INSTRUMENTS & FACILITIES

The following test Instruments was used during the radiated emission test :

| Item | Instruments /facilities    | Specification                   | Manufacturer    | Model # / S/N#              | Date of Cal. |
|------|----------------------------|---------------------------------|-----------------|-----------------------------|--------------|
| 1    | EMI Receiver               | 9KHz ~ 30MHz                    | ROHDE & SCHWARZ | ESHS 30<br>844827/007       | MAR/2004     |
| 2    | LISN<br>(for EUT)          | 50 /50uH/100A<br>150KHz ~ 30MHz | SCHWARZ<br>BECK | NNLK 8121<br>8121370        | OCT/2003     |
| 3    | LISN<br>(for Support Unit) | 50 /50uH/10A<br>9KHz ~ 30MHz    | ROHDE & SCHWARZ | ESH3-Z5<br>846128/007       | FEB/2004     |
| 4    | Terminator                 | 50                              | N/A             | N/A                         | NOV/2003     |
| 5    | Attenuation                | 50 /10dB                        | Mini-Circuit    | NAT-10<br>AT-002            | JUL/2004     |
| 6    | Cable                      | 3m                              | SUHNER          | RG-223<br>CON2-001          | DEC/2003     |
| 7    | ESXS-K1<br>(software)      | Version 2.03b<br>9KHz ~ 30MHz   | ROHDE & SCHWARZ | 1082.9678.02<br>840.913/246 | N/A          |

Note : Items 1 ~ 9 were calibrated within period of 1 year.

## 2 TEST PROCEDURE

- 2.1 The EUT was test according to **CISPR 22 Class B**.
- 2.2 The radiated test was performed at HomeTek Lab' s Open Site III.
- 2.3 The frequency range from 30 MHz to 1 GHz, the measurement were made at 10 meters, with a BI-log antenna.

## 3 TEST SETUP

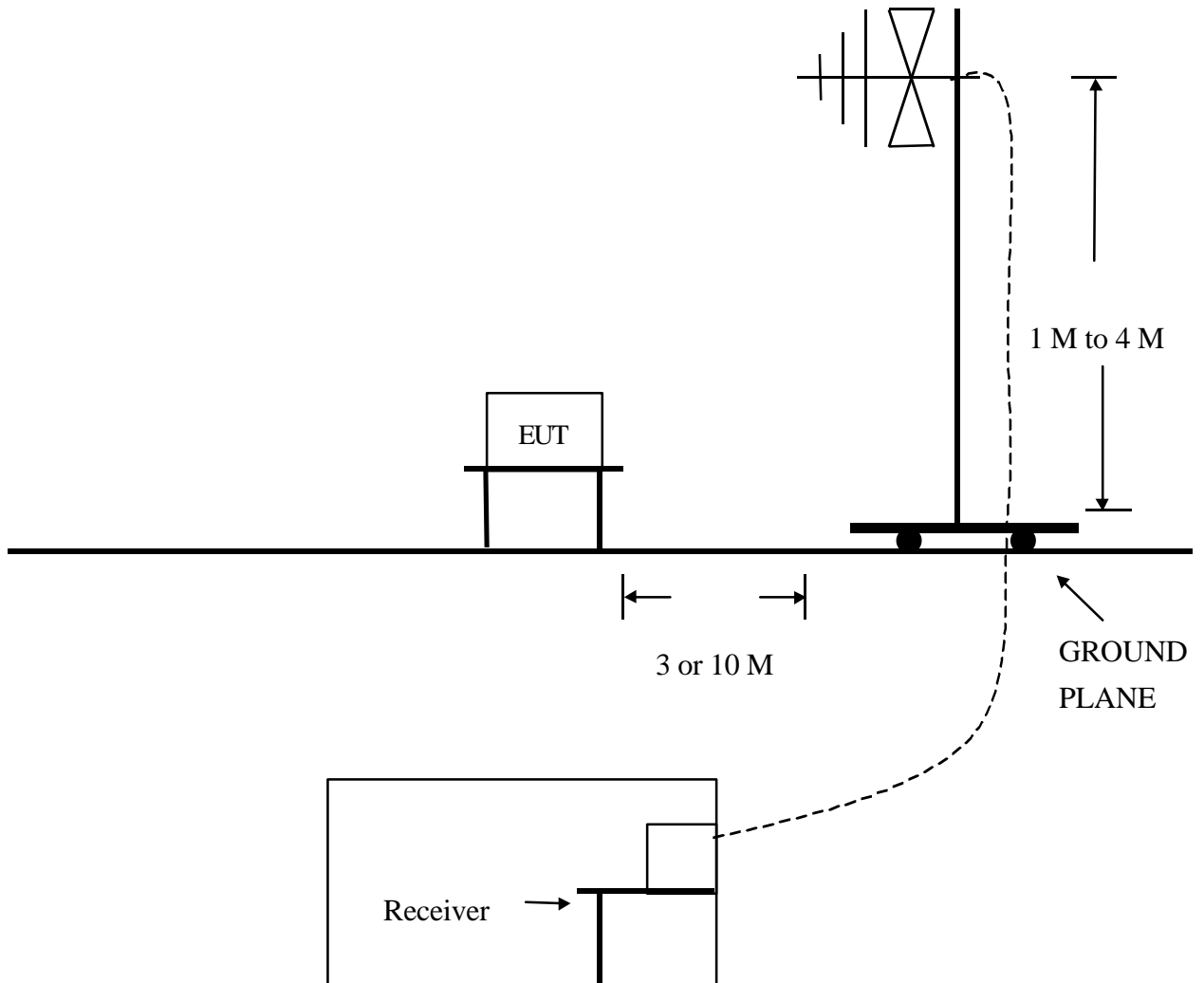

(Details for setup configuration, please refer to appendix A.)

#### 4 CONFIGURATION OF THE EUT

The EUT was configured according to **EN 61000-6-3**. All I/O ports were connected to the appropriate peripherals. All peripherals and cables are listed below (including internal device) :

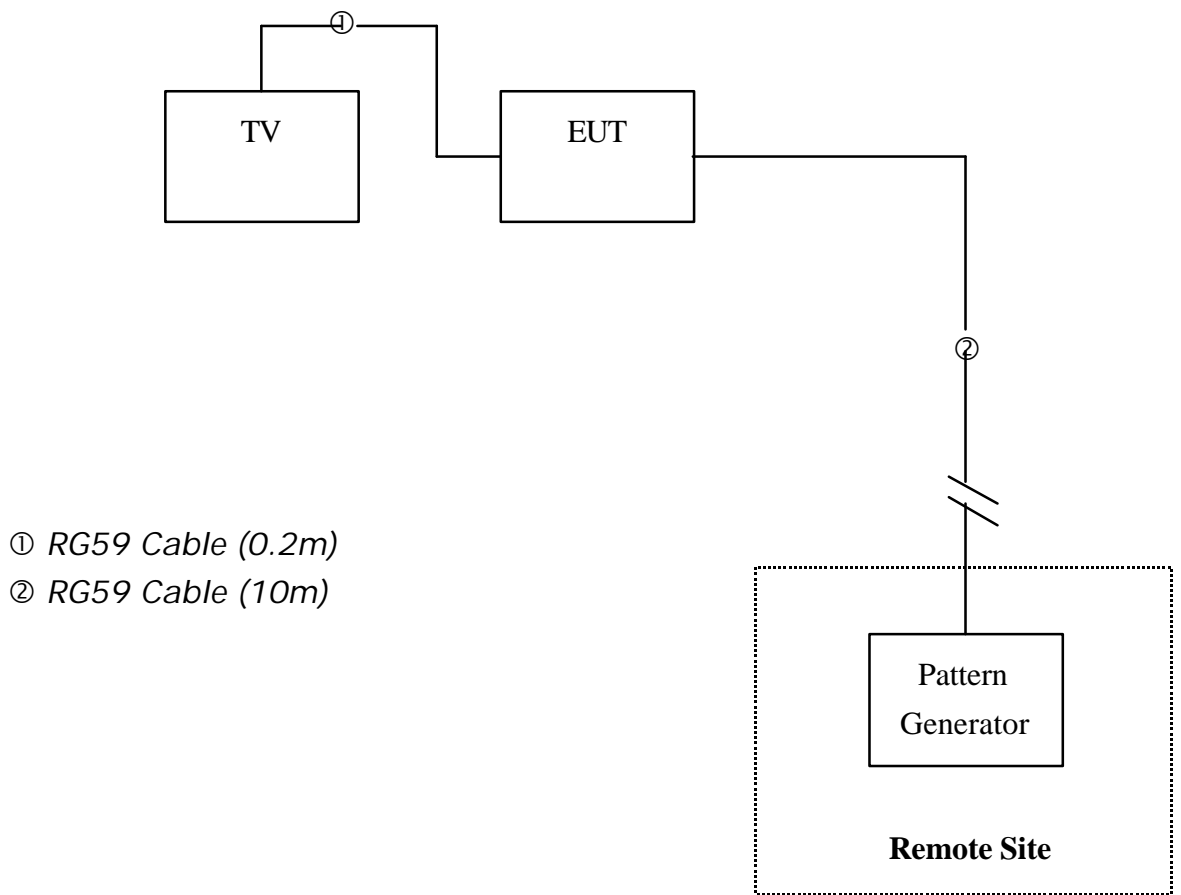

Figure 1



#### 4.1 EUT

EUT Type : Proto Type Engineer Type Mass Production  
Condition when received : Good Damage : \_\_\_\_\_  
Device : Video Ground Loop Isolator  
Applicant : SMART CABLING & TRANSMISSION CORP.  
Manufacturer : SMART CABLING & TRANSMISSION CORP.  
Model Number : GL00X, GB00X (X = 1~9)  
Serial Number : N/A  
FCC ID : N/A  
Data Cable1 (RG59) : Shielded, 0.2 m, Metal Type Connector  
Data Cable2 (RG59) : Shielded, 10 m, Metal Type Connector  
Power Cord : N/A  
Power Supply Type : N/A

#### 4.2 PERIPHERALS

TV

Manufacturer : TLC  
Model Number : 1419A  
Serial Number : N/A  
FCC ID : FCC DoC  
Data Cable : Shielded, 0.2 m  
Power Cord : Un-Shielded, 1.0 m



Pattern Generator (Remote Site)

Manufacturer : LEADER  
Model Number : 408  
Serial Number : 3037775  
FCC ID : N/A  
Data Cable : Shielded, 10 m  
Power Cord : Un-Shielded, 1.8 m

4.3 REMARK : N/A

5 EUT OPERATING CONDITION

- 5.1 Configure the EUT according to the **EN 61000-6-3**.
- 5.2 The frequency of the EUT is none.
- 5.3 Turn on all the power of peripheral.
- 5.4 Remote pattern generator sends color bar signal to EUT.
- 5.5 Monitor the output signal of EUT during the test. (For EMS testing)
- 5.6 The photos of radiated test configuration, please refer to appendix A.**

6 LIMIT OF RADIATED EMISSION CLASS B

| Frequency<br>(MHz) | Measurement<br>Distance | Limit (dBuV/m) |
|--------------------|-------------------------|----------------|
| 30 - 230           | 10 (M)                  | 30             |
| 230 - 1000         | 10 (M)                  | 37             |

7 RESULT OF RADIATED EMISSION TEST

- 7.1 The frequency range from 30 MHz to 1 GHz was investigated.
- 7.2 All readings below or equal 1 GHz are quasi-peak or peak values with resolution bandwidth of 120 KHz.
- 7.3 The measurements were made at 10 meters of HomeTek Lab’s open site III.
- 7.4 Temperature : 33 , Humidity : 55 % RH.
- 7.5 Deviation form the test standards and rules : None.
- 7.6 The radiated emission result were gained by the following method :  
 Level = Reading Level + Probe Factor (Antenna Factor) + Cable Loss – Preamp Factor  
 Over Limit = Level – Limit Line
- 7.7 Result : **PASSED**  
 (Result of radiated emission test data were shown as following two pages.)



HomeTek Technology Inc.

No 67-9, Shi-Men Rd; , Tu-Chen City,  
 Taipei County, Taiwan R.O.C.  
 Tel: 02-22608375  
 Fax: 02-22748013

Data#: 1 File#: 3h007.emi

Date: 2004-08-12 Time: 09:27:21

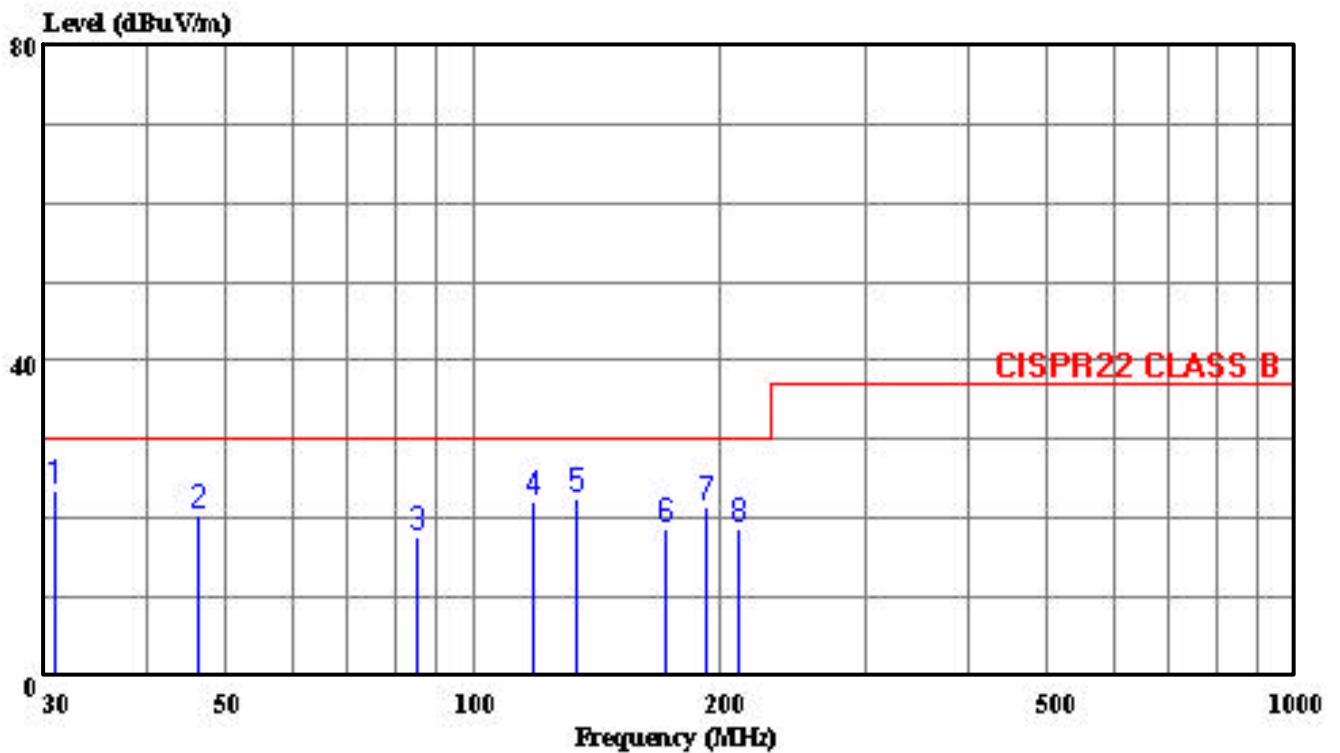

Trace:

Ref Trace:

Condition: CISPR22 CLASS B 10m CHASE 2614 052604 HORIZONTAL  
 eut : Video Ground Loop Isolator  
 power: N/A  
 memo : GB001

Page: 1

|      | Limit   | Over   | ReadAntenna | Cable  | Preamp |       |        |            |
|------|---------|--------|-------------|--------|--------|-------|--------|------------|
| Freq | Level   | Line   | Limit       | Level  | Factor | Loss  | Factor | Remark     |
| MHz  | dBuV/m  | dBuV/m | dB          | dBuV   | dB/m   | dB    | dB     |            |
| 1    | 30.820  | 23.51  | 30.00       | -6.49  | 33.78  | 17.10 | 0.83   | 28.20 Peak |
| 2    | 46.230  | 20.42  | 30.00       | -9.58  | 37.87  | 9.70  | 1.05   | 28.20 Peak |
| 3    | 85.130  | 17.82  | 30.00       | -12.18 | 36.84  | 7.83  | 1.36   | 28.21 Peak |
| 4    | 118.247 | 22.21  | 30.00       | -7.79  | 37.13  | 11.67 | 1.56   | 28.15 Peak |
| 5    | 133.468 | 22.51  | 30.00       | -7.49  | 37.90  | 11.08 | 1.64   | 28.10 Peak |
| 6    | 170.975 | 18.72  | 30.00       | -11.28 | 36.29  | 8.60  | 1.82   | 27.99 Peak |
| 7    | 192.110 | 21.41  | 30.00       | -8.59  | 38.70  | 8.70  | 1.93   | 27.92 Peak |
| 8    | 210.374 | 18.75  | 30.00       | -11.25 | 36.12  | 8.50  | 2.01   | 27.88 Peak |



Data#: 2 File#: 3h007.emi

Date: 2004-08-12 Time: 09:57:51

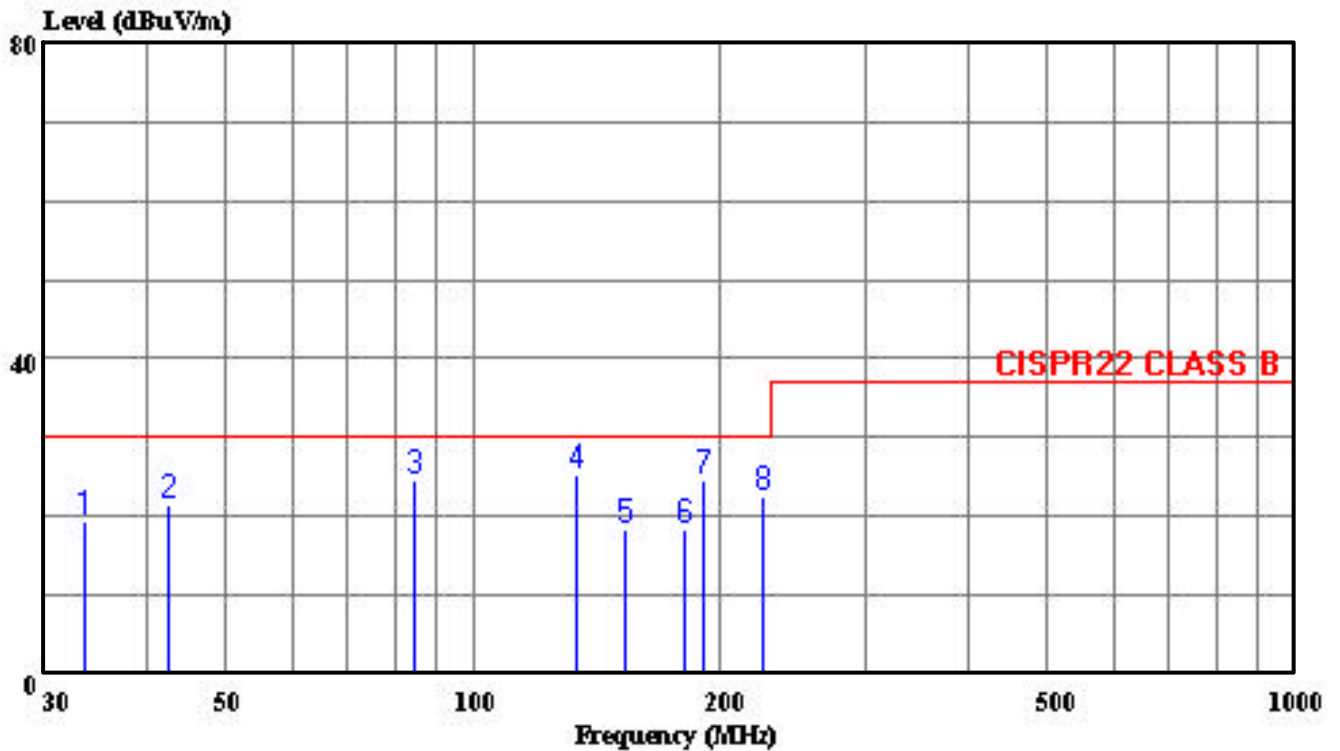

Trace:

Ref Trace:

Condition: CISPR22 CLASS B 10m CHASE 2614 052604 VERTICAL  
 eut : Video Ground Loop Isolator  
 power: N/A  
 memo : GB001

Page: 1

|   | Freq    | Level  | Limit  | Over   | ReadAntenna | Cable | Preamp | Remark     |
|---|---------|--------|--------|--------|-------------|-------|--------|------------|
|   | MHz     | dBuV/m | dBuV/m | dB     | dBuV        | dB/m  | dB     | dB         |
| 1 | 33.724  | 19.41  | 30.00  | -10.59 | 30.41       | 16.32 | 0.88   | 28.20 Peak |
| 2 | 42.490  | 21.44  | 30.00  | -8.56  | 37.17       | 11.47 | 1.00   | 28.20 Peak |
| 3 | 84.750  | 24.75  | 30.00  | -5.25  | 43.82       | 7.78  | 1.36   | 28.21 Peak |
| 4 | 133.489 | 25.14  | 30.00  | -4.86  | 40.53       | 11.08 | 1.64   | 28.10 Peak |
| 5 | 152.347 | 18.43  | 30.00  | -11.57 | 35.33       | 9.41  | 1.73   | 28.05 Peak |
| 6 | 180.413 | 18.52  | 30.00  | -11.48 | 36.01       | 8.60  | 1.87   | 27.96 Peak |
| 7 | 191.113 | 24.51  | 30.00  | -5.49  | 41.86       | 8.66  | 1.92   | 27.92 Peak |
| 8 | 224.170 | 22.52  | 30.00  | -7.48  | 39.54       | 8.75  | 2.08   | 27.86 Peak |



## **HARMONICS TEST**

### **1 TEST PROCEDURE**

According to **EN 61000-3-2 (2000)**.

### **2 RESULT OF HARMONICS TEST**

N/A (This standard is not applicable to this EUT ( Model : GB001)).



## **VOLTAGE FLUCTUATIONS TEST**

### **1 TEST PROCEDURE**

According to **EN 61000-3-3 (1995) + A1 (2001)**.

### **2 RESULT OF VOLTAGE FLUCTUATIONS TEST**

N/A (This standard is not applicable to this EUT ( Model : GB001)).

## ELECTROSTATIC DISCHARGE IMMUNITY TEST (ESD)

### 1 TEST INSTRUMENTS & FACILITIES

| Instruments/<br>Facilities | Manufacturer | Model #<br>Serial # | Data Of Cal. |
|----------------------------|--------------|---------------------|--------------|
| ESD TESTER                 | NOISEKEN     | ESS-100L (A)        | OCT/2003     |
| VCP                        | HOMETEK      | --                  | --           |
|                            |              |                     |              |

### 2 TEST PROCEDURE

According to **IEC 61000-4-2 (1995) + A1 (1998)**

According to **EN 50130-4 (1996) + A1 (1998)**

### 3 TEST SETUP

TABLE SIZE

160L X 80W X 80H cm

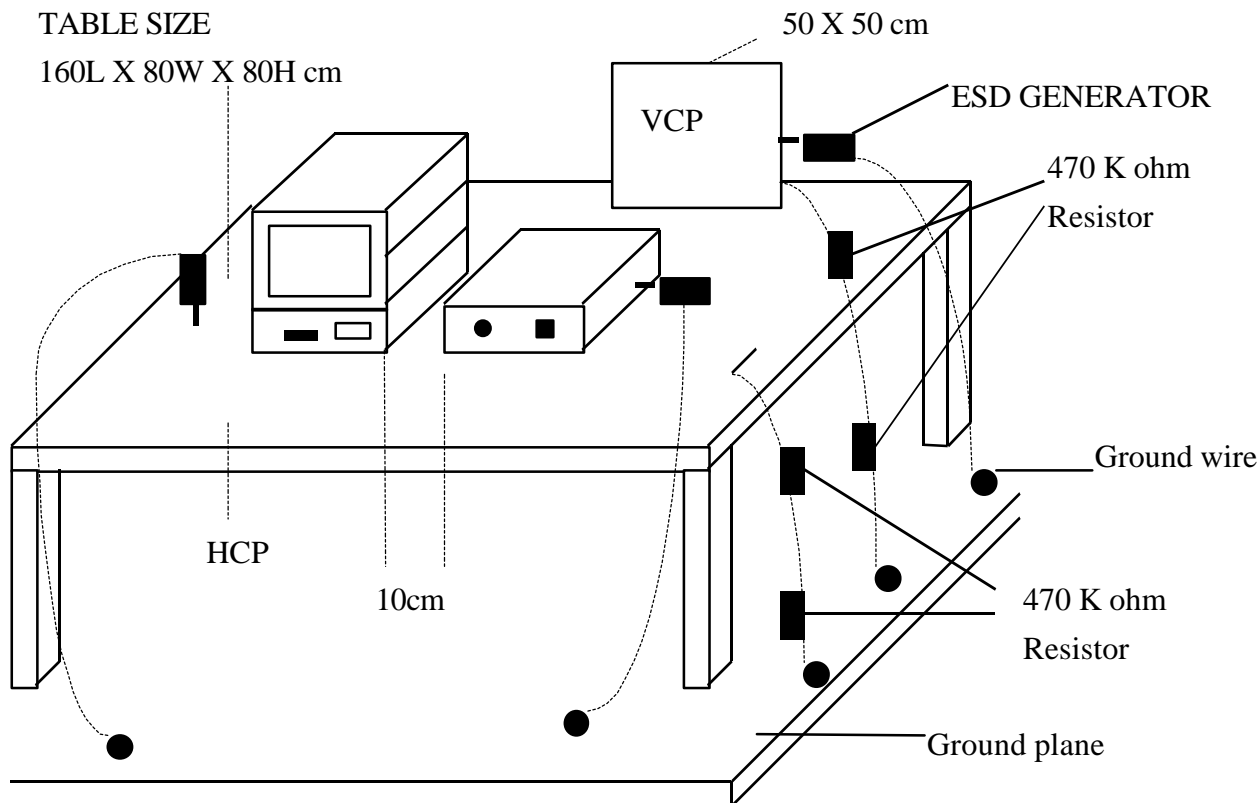

(Details for setup configuration, please refer to appendix A.)

#### 4 CONFIGURATION OF THE EUT

Same as “Radiated Emission test”, section 4

#### 5 EUT OPERATION CONDITION

Same as “Radiated Emission test”, section 5

#### 6 TEST CONDITION

##### 6.1 Test Level :

(A)  $\pm 2, 4, 8$ KV for air discharge.

(B)  $\pm 2, 4, 6$ KV for contact discharge.

6.2 Number of test : 10 Discharges / Test point / Polarity / Level

6.3 Time between test : 1 sec.

6.4 Temperature : 24

6.5 Humidity : 50 % RH.

#### 7 PERFORMANCE CRITERIA

There shall be no damage, malfunction or change of status due to the conditioning. Flickering of an indicator during the application of the discharges is permissible, providing that there is no residual change in the EUT or any change in outputs, which could be interpreted by associated equipment as a change.

The EUT shall meet the acceptance criteria for the functional test, after the conditioning.

8 TEST RESULT

| Test Point | Air Discharge | Contact Discharge | Result        |
|------------|---------------|-------------------|---------------|
| HCP        | ± 2, 4, 8KV   | ± 2, 4, 6KV       | <b>PASSED</b> |
| VCP        | ± 2, 4, 8KV   | ± 2, 4, 6KV       | <b>PASSED</b> |
| CASE       | ± 2, 4, 8KV   | ± 2, 4, 6KV       | <b>PASSED</b> |
| I/O PORTS  | ± 2, 4, 8KV   | ± 2, 4, 6KV       | <b>PASSED</b> |
| SCREWS     | ± 2, 4, 8KV   | ± 2, 4, 6KV       | <b>PASSED</b> |

There is no significant change during the test.

9 Photos of test configuration please refer to appendix A.

## RADIO FREQUENCY ELECTROMAGNETIC FIELD IMMUNITY TEST (RS)

### 1 TEST INSTRUMENTS & FACILITIES

| Item | Instruments<br>Facilities | Manufacturer          | Model #<br>Serial # | Data Of Cal. |
|------|---------------------------|-----------------------|---------------------|--------------|
| 1    | SIGNAL<br>GENERATOR       | ROHDE &<br>SCHWARZ    | SMY02<br>845181/025 | MAR/2004     |
| 2    | AMPLIFIER                 | AMPLIFIER<br>RESEARCH | 100W1000M1A         | N/A          |
| 3    | FIELD SENSOR              | AMPLIFIER<br>RESEARCH | FP2000              | AUG/2002     |
| 4    | FIELD MONITOR             | AMPLIFIER<br>RESEARCH | FM2000              | AUG/2002     |
| 5    | RF VOLTMETER              | BOONTON               | 9200C<br>361701AA   | MAR/2004     |
| 6    | RF PROBE                  | BOONTON               | 952001B<br>37082    | MAR/2004     |
| 7    | DIRECTION<br>COUPLER      | AMPLIFIER<br>RESEARCH | DC6180<br>20521     | N/A          |
| 8    | ANTENNA                   | EMCO                  | 3142B<br>S/N: 1789  | N/A          |
| 9    | CONTROL<br>PC             | KB TECH               | KB P586/133         | --           |

Note : Items 3 ~ 4 were calibrated with two years and verified before testing.

### 2 TEST PROCEDURE

According to **IEC 61000-4-3 (1995) + A1 (1998)**

According to **EN 50130-4 (1996) + A1 (1998)**

### 3 TEST SETUP

#### FERRITE TILE

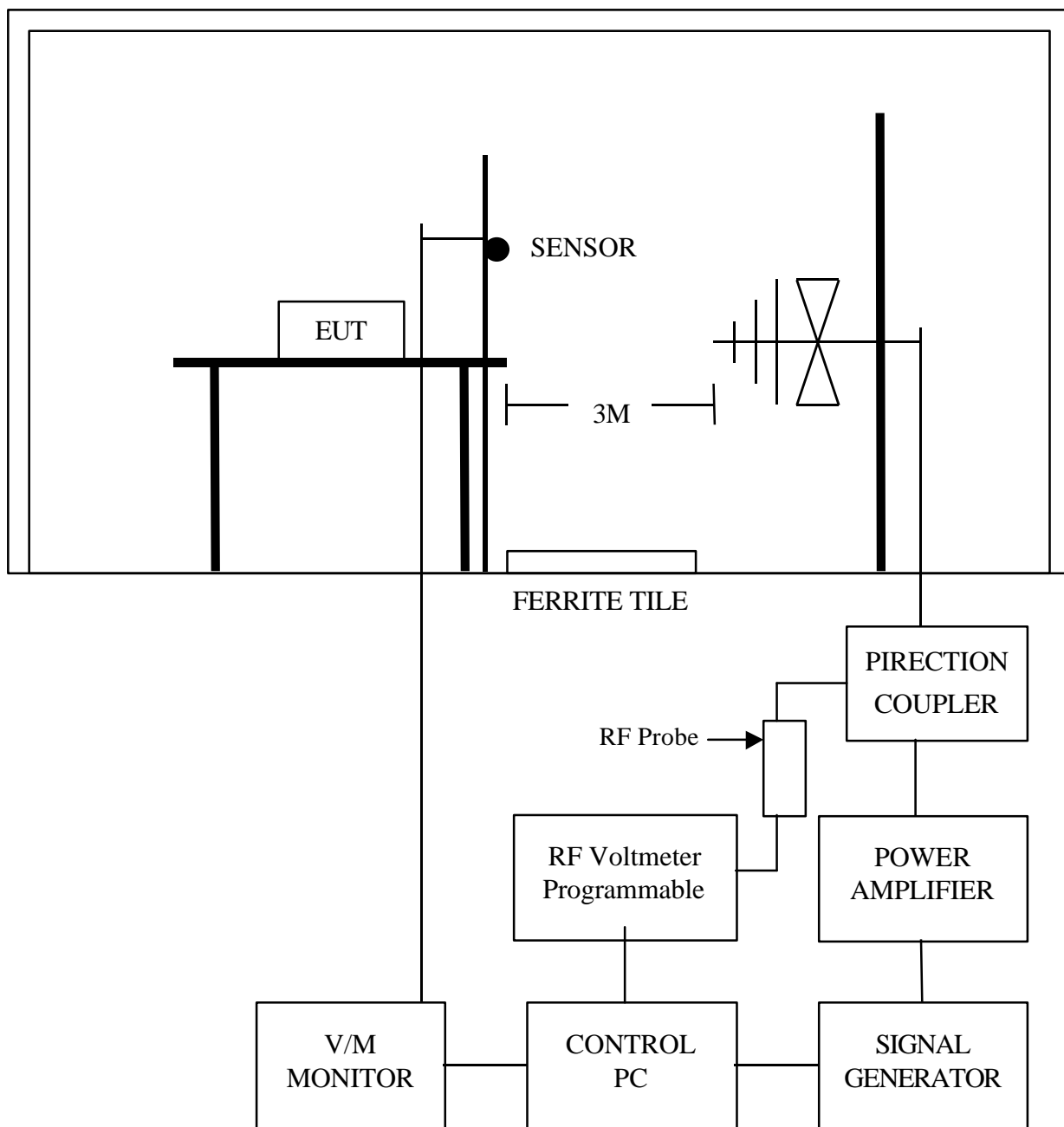

3.1 Chamber Size :

12M x 5M x 5M

(Details for setup configuration, please refer to appendix A.)

#### 4 CONFIGURATION OF THE EUT

Same as “Radiated Emission test”, section 4

#### 5 OPERATION CONDITION OF EUT

Same as “Radiated Emission test”, section 5

#### 6 TEST CONDITION

6.1 Frequency Range : 80 MHz ~ 1000 MHz

6.2 Field Strength : 10 V / M (1KHz 80% Sinusoidal amplitude modulation)  
10 V / M (1KHz 0.5s on : 0.5s off pulse modulation)

6.3 Frequency Step : 1 %, 3 sec. / each step size

6.4 Antenna Polarity : HORIZONTAL & VERTICAL

6.5 The four sides of EUT are tested  
(FRONT, REAR, RIGHT, LEFT)

6.6 Temperature : 27

6.7 Humidity : 60 % RH

#### 7 PERFORMANCE CRITERIA

There shall be no damage, malfunction or change of status due to the conditioning. Flickering of an indicator during the conditioning is permissible, providing that there is no residual change in the EUT or any change in outputs, which could be interpreted by associated equipment as a change, and no such flickering of indicators occurs at a field strength of 3 V/m.

For components of CCTV system, where the status is monitored by observing the TV picture, then deterioration of the picture is allowed at 10 V/m, providing :

- a There is no permanent damage or change to the EUT (e.g. no corruption of memory or changes to programmable setting etc.);
- b At 3 V/m, any deterioration of the picture is so minor that the system could still be used;
- c There is no observable deterioration of the picture at 1 V/m.

The EUT shall meet the acceptance criteria for the functional test, after the conditioning.

**8 TEST RESULT**

| ANT<br>SIDE | HORIZONTAL | VERTICAL |
|-------------|------------|----------|
| FRONT       | PASSED     | PASSED   |
| REAR        | PASSED     | PASSED   |
| RIGHT       | PASSED     | PASSED   |
| LEFT        | PASSED     | PASSED   |

**9 Photos of test configuration please refer to appendix A.**

## ELECTRICAL FAST TRANSIENT/BURST IMMUNITY TEST (EFT)

### 1 TEST INSTRUMENTS & FACILITIES

| Instruments/<br>Facilities | Manufacturer | Model #<br>Serial # | Data Of Cal. |
|----------------------------|--------------|---------------------|--------------|
| BURST-TESTER               | HAEFELY      | PEFT/JUNIOR         | FEB/2004     |
| CONTROL PC                 | KB TECH      | KB P586/133         | --           |
|                            |              |                     |              |

### 2 TEST PROCEDURE

According to **IEC 61000-4-4 (1995)**

According to **EN 50130-4 (1996) + A1 (1998)**

### 3 TEST SETUP

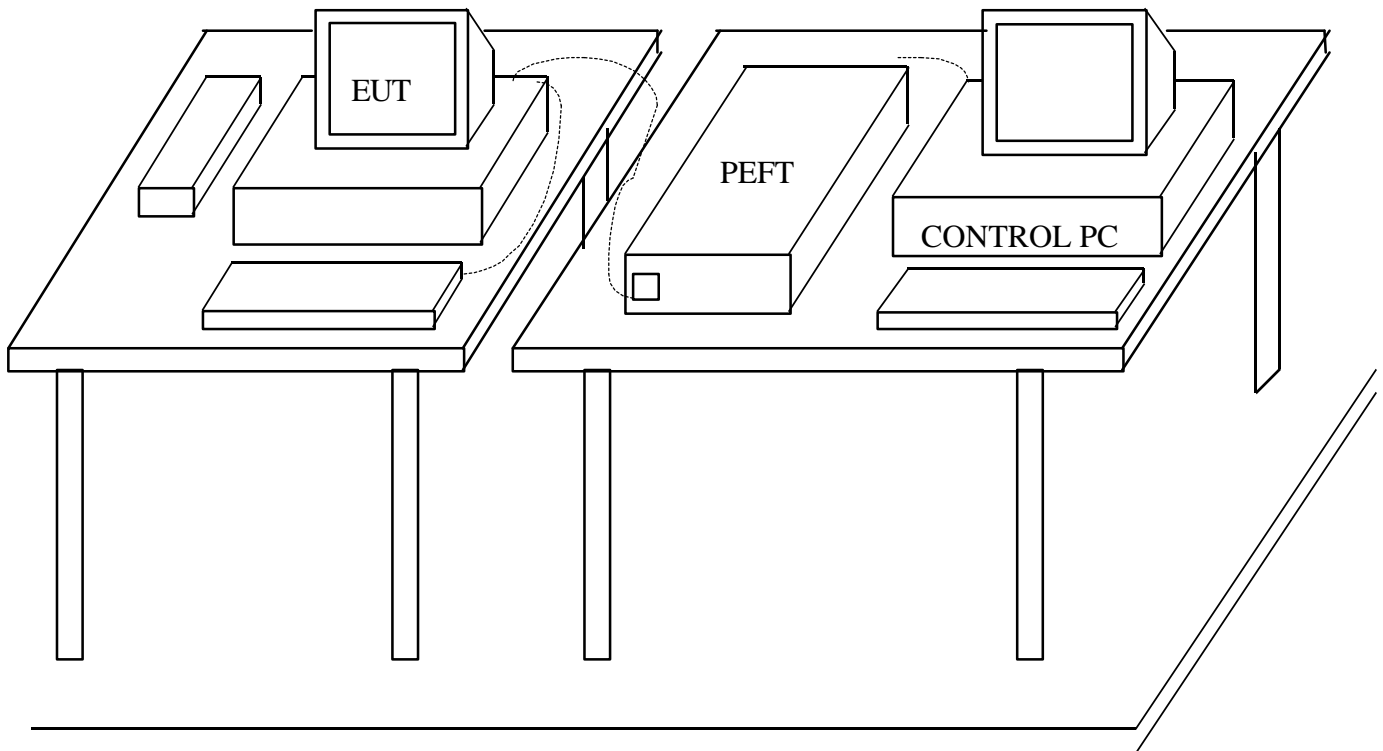

**GROUND PLANE**

(Details for setup configuration, please refer to appendix A.)

#### 4 CONFIGURATION OF THE EUT

Same as “Radiated Emission test”, section 4

#### 5 OPERATION CONDITION OF EUT

Same as “Radiated Emission test”, section 5

#### 6 TEST CONDITION

6.1 Pulse Rise time & Duration : 5 nS / 50 nS

6.2 Pulse Repetition : 5 kHz

6.3 Polarity : POSITIVE / NEGATIVE

6.4 Test Voltage of Power Line :  $\pm 0.5KV$ ,  $\pm 1KV$ ,  $\pm 2KV$

6.5 Coupling of power line :  
L, N, PE, L+N, L+PE, N+PE, L+N+PE

6.6 Test Voltage of Signal Control Line :  $\pm 0.25KV$ ,  $\pm 0.5KV$ ,  $\pm 1KV$

6.7 Temperature : 27

6.8 Humidity : 60 % RH

#### 7 PERFORMANCE CRITERIA

There shall be no damage, malfunction or change of status due to the conditioning. Flickering of an indicator during the application of the bursts is permissible, providing that there is no residual change in the EUT or any change in outputs, which could be interpreted by associated equipment as a change.

The EUT shall meet the acceptance criteria for the functional test, after the conditioning.

## 8 TEST RESULT

Power Line :

N/A (This standard is not applicable to this EUT ( Model : GB001)).

Signal Control Line :

| TEST VOLTAGE | PERFORMACE CRITERIA |
|--------------|---------------------|
| ± 0.25KV     | ✓                   |
| ± 0.5KV      | ✓                   |
| ± 1KV        | ✓                   |

The screen was flash during the test.

8.1 Model : GB001

8.2 Final Result : PASSED

8.3 Remark :

## 9 Photos of test configuration please refer to appendix A.

## **SURGE IMMUNITY TEST**

### **1 TEST PROCEDURE**

According To **IEC 61000-4-5 (1995)**

According To **EN 50130-4 (1996) + A1 (1998)**

### **2 RESULT OF SURGE IMMUNITY TEST**

N/A (This standard is not applicable to this EUT ( Model : GB001)).

## **IMMUNITY TEST TO CS CONDUCTED DISTURBANCE**

### **1 TEST PROCEDURE**

According To **ENV 50141 (1993)**

According To **EN 50130-4 (1996) + A1 (1998)**

### **2 RESULT OF IMMUNITY TEST TO CS CONDUCTED DISTURBANCE**

N/A (This standard is not applicable to this EUT ( Model : GB001)).

## **VOLTAGE DIPS, SHORT INTERRUPTIONS IMMUNITY TEST**

### **1 TEST PROCEDURE**

According To **IEC 61000-4-11 (1994)**

According To **EN 50130-4 (1996) + A1 (1998)**

### **2 RESULT OF VOLTAGE DIPS, SHORT INTERRUPTIONS IMMUNITY TEST**

N/A (This standard is not applicable to this EUT ( Model : GB001)).



HomeTek Technology Inc.

## **Appendix A**

# **PHOTOS OF TEST CONFIGURATION**

## PHOTO OF RADIATED EMISSION TEST

Model : GB001



Front View

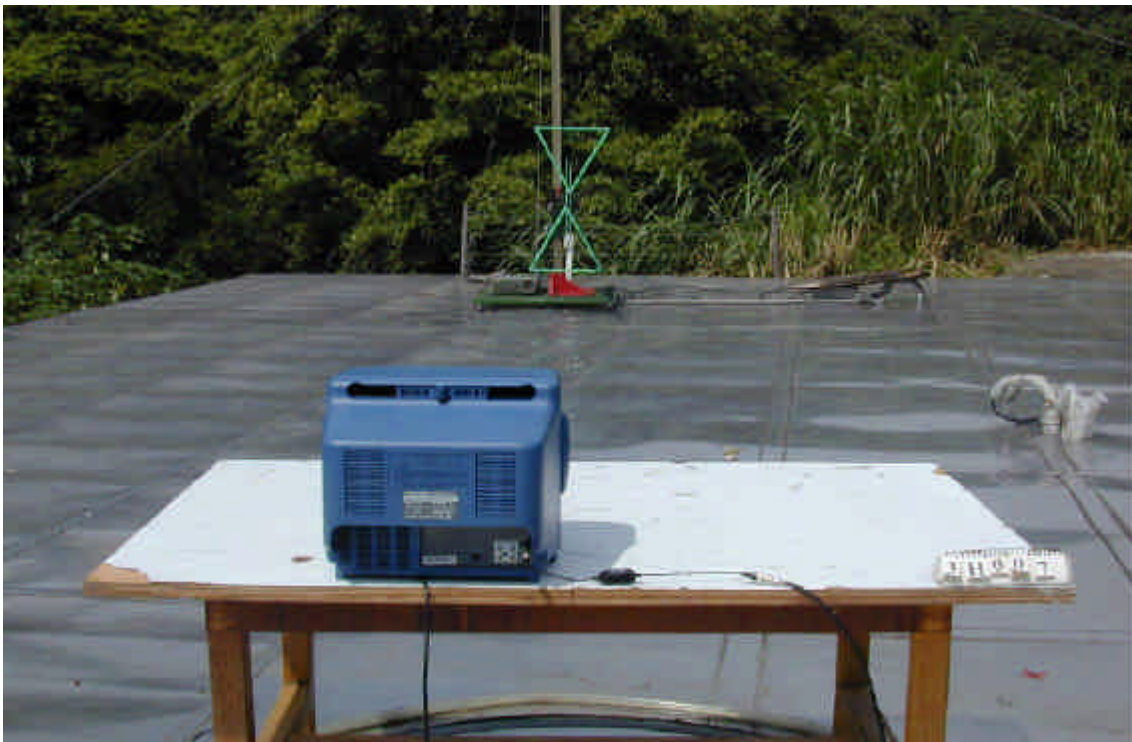

Rear View

**PHOTO OF ELECTRICAL FAST TRANSIENT/BURST IMMUNITY  
TEST ( EFT )**

Model : GB001



Signal Control Line Test



**PHOTO OF ELECTROSTATIC DISCHARGE IMMUNITY TEST**

**(ESD)**

Model : GB001



Front View

**PHOTO OF RADIO FREQUENCY ELECTROMAGNETIC FILE  
IMMUNITY TEST (RS)**

Model : GB001



Front View



HomeTek Technology Inc.

## **Appendix B**

# **PHOTOS OF EUT**

### PHOTO OF EUT

Model : GB001 , GL001



Front View of EUT



Rear View of EUT

### PHOTO OF EUT

Model : GB001

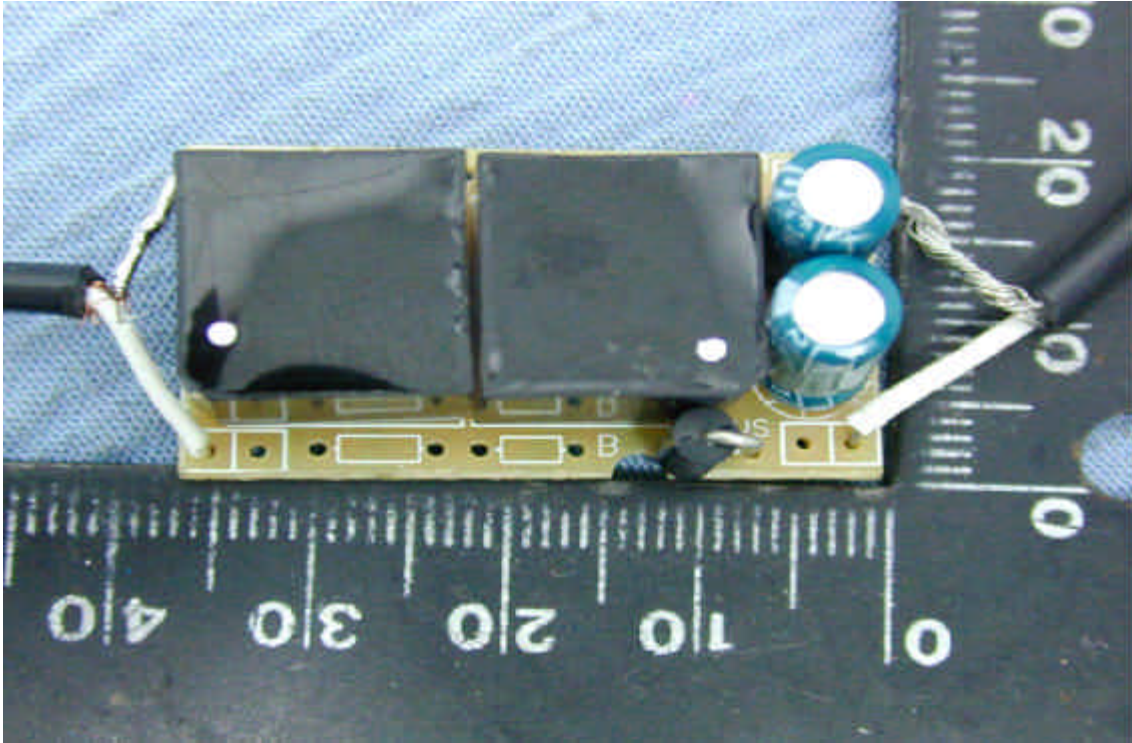

Component Side of Main Board

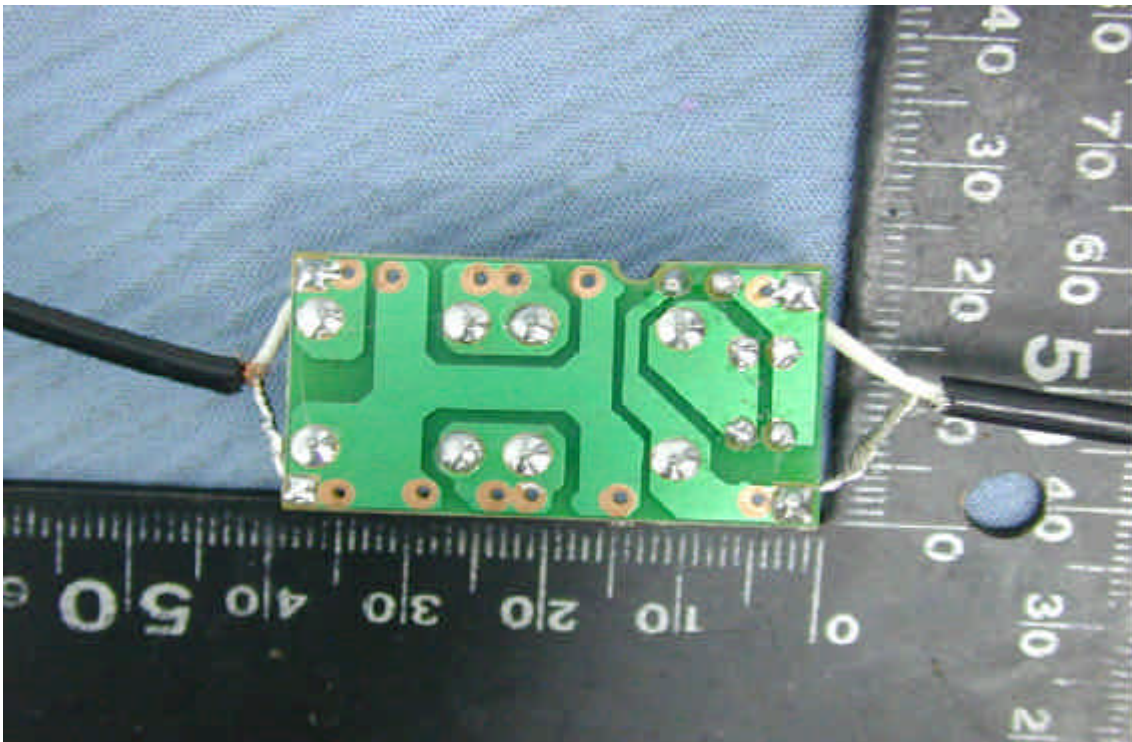

Solder Side of Main Board

### PHOTO OF EUT

Model : GL001

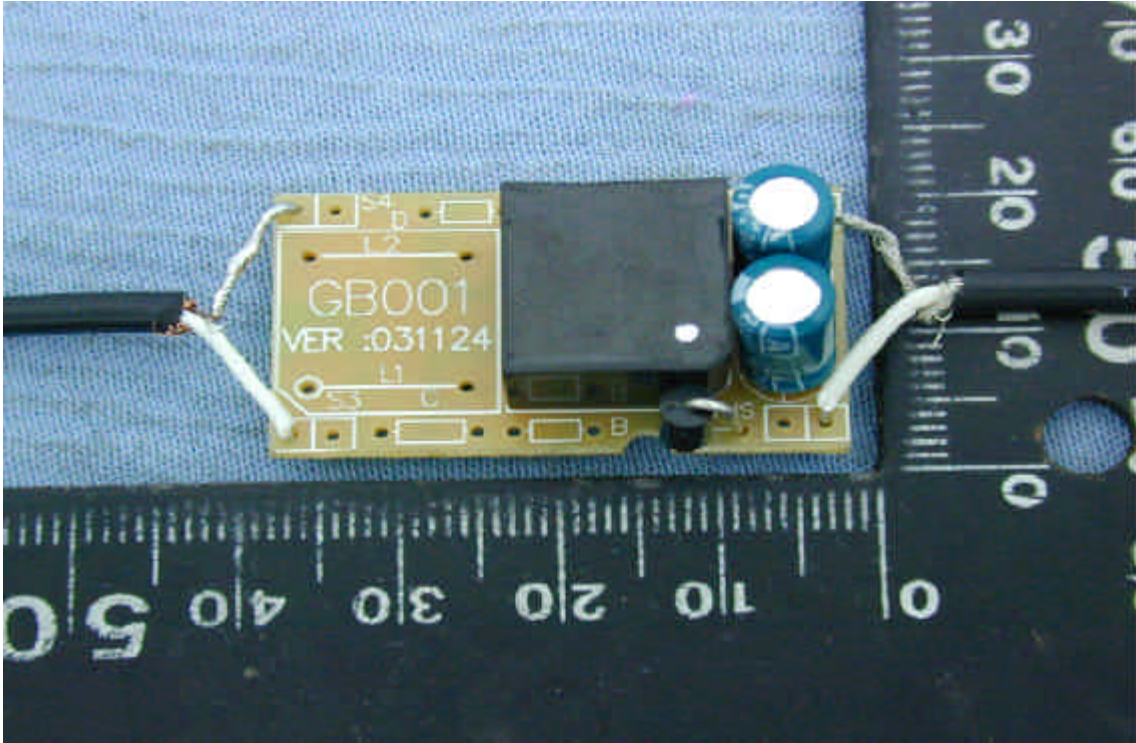

Component Side of Main Board

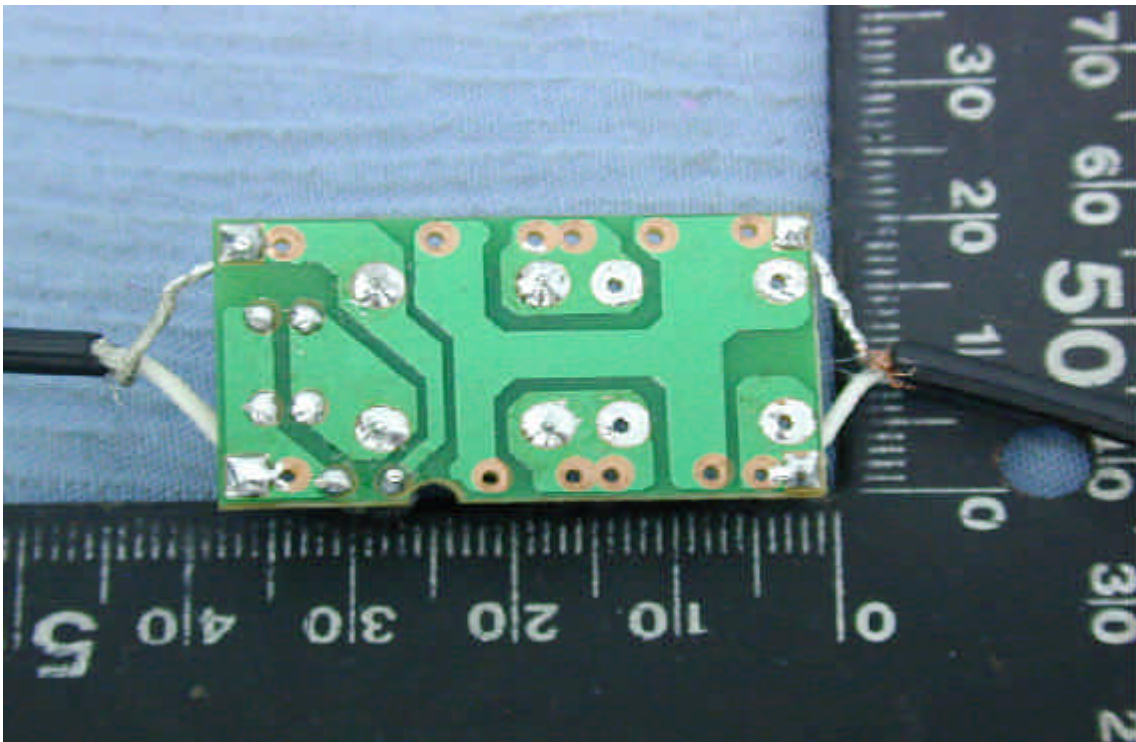

Solder Side of Main Board

# Declaration of Conformity

We(Manufacturer/Importer)

---

(company name)

---

(address)

declares under our sole responsibility that the product

Product name : Video Ground Loop Isolator

Model No. : GL00X, GB00X (X = 1~9)

to which this declaration relates is in conformity with the following standard(s) or other normative document(s)

- |  |   |
|--|---|
| <input checked="" type="checkbox"/> EN 61000-6-3 (2001)                | <input checked="" type="checkbox"/> EN 50130-4 (1996)<br>+ A1 (1998)    |
| <input checked="" type="checkbox"/> CISPR 22 Class B (1997)            | <input checked="" type="checkbox"/> IEC 61000-4-2 (1995)<br>+ A1 (1998) |
| <input checked="" type="checkbox"/> EN 61000-3-2 (2000)                | <input checked="" type="checkbox"/> IEC 61000-4-3 (1995)<br>+ A1 (1998) |
| <input checked="" type="checkbox"/> EN 61000-3-3 (1995)<br>+ A1 (2001) | <input checked="" type="checkbox"/> IEC 61000-4-4 (1995)                |
|  | <input checked="" type="checkbox"/> IEC 61000-4-5 (1995)                |
|  | <input checked="" type="checkbox"/> ENV 50141 (1993)                    |
|  | <input checked="" type="checkbox"/> IEC 61000-4-11 (1994)               |

following the provisions of 89/336/EEC Directive

Place: \_\_\_\_\_ Signature: \_\_\_\_\_

Date : \_\_\_\_\_ Full name: \_\_\_\_\_



Title: \_\_\_\_\_

## EMC Laboratory Authorisation

Aut. No.: ELA 183

EMC Laboratory: **HomeTek Technology Inc.**  
**P.O.Box 13-131, Pan-Chiao City,**  
**No. 67-9, Shi-Men Rd., Tu-Chen City,**  
**Taipei Shien**  
**Taiwan R.O.C.**

Scope of  
Authorization: **All CENELEC standards [ENs] for EMC that are listed on the  
accompanying page, and, all of the corresponding CISPR,  
IEC, and ISO EMC standards that are listed on the  
accompanying page.**

Nemko has assessed the testing facilities, qualifications and testing practices and the relevant part of the organization. The above-mentioned EMC Laboratory has been validated against EN 45001 and ISO 17025 and found to be compliant. The laboratory also fulfils the conditions described in Nemko Document ELA-INFO-10. During Nemko's visit it was found that the EMC Laboratory is capable of performing tests within the Scope of Authorisation given on the accompanying page(s).

Accordingly, Nemko will accept test reports from the laboratory as a basis for attesting conformity to these EMC Standards under either the European Union EMC Directive (89/336/EEC) or, when applicable, the national standards of countries Nemko has been authorised to attest conformity with.

In order to maintain the Authorisation, the information given in the pertinent ELA-INFO-10 must be carefully followed. Nemko is to be promptly notified about any changes in the situation at the EMC Laboratory, which may affect the basis for this Authorisation. The Authorisation may be withdrawn at any time if the conditions are no longer considered to be fulfilled.

**The Authorisation is valid through 31 December 2004.**

Oslo, 28 November 2002

For Nemko AS:

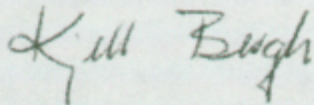

Kjell Bergh, Nemko Group EMC Co-ordinator

## EMC Laboratory Authorisation

Aut. No.: ELA 183

### SCOPE OF AUTHORIZATION

#### GENERIC & PRODUCT-FAMILY STANDARDS

|  |  |  |
|--|--|--|
| EN 50081-1:1992<br>EN 61000-6-3: 2001<br>IEC 61000-6-3:1996 (mod)  | EN 50082-1 :1997<br>EN 61000-6-1:2001<br>IEC 61000-6-1:1997 (mod)  | EN 61000-6-2:1999<br>IEC 61000-6-2:1999<br>EN 61000-6-2: 2001<br>IEC 61000-6-2:1999 (mod)  |
| EN 50081-2:1993<br>EN 61000-6-4 : 2001<br>IEC 61000-6-4:1997 (mod)   | EN 55014-1:1993 + A1:1997 +<br>A2 :1999<br>CISPR 14:1993 + A1:1996 +<br>A2 :1998<br>EN 55014-1 :2000 + A1 :2001<br>CISPR 14-1 :2000 + A1 :2001 | EN 55014-2:1997<br>CISPR 14-2:1997   |
| EN 61000-3-2:1995 + A1:1998 +<br>A2:1998 + A14 :2000<br>IEC 61000-3-2:1995 + A1:1997 +<br>A2:1998<br>EN 61000-3-2 :2000<br>IEC 61000-3-2 :2000 (mod) +<br>A1 :2001 | EN 61000-3-3 :1995 + A1 :2001<br>IEC 61000-3-3 :1994 + A1 :2001<br><br>EN 61000-3-11 :00<br>IEC 61000-3-11 :00                                 | EN 55022:1994 + A1:1995 +<br>A2:1997<br>CISPR 22:1993 + A1:1995 +<br>A2:1996<br><br>EN 55022:1998 + A1 :2000<br>CISPR 22:1997 + A1 :2000 |
| EN 55024:1998 + A1 :2001<br>CISPR 24:1997 + A1 :2001   | EN 50091-2:1995  | EN 60945:1997<br>IEC 60945:1996  |
| EN 55013: 1990 + A12 :1994 +<br>A13 :1996 + A14 :1999<br>CISPR 13 :1975 + A1 :1983 (mod)<br>EN55013: 2001<br>CISPR 13 : 2001 (mod)                                 |  |  |

#### BASIC STANDARDS

|  |   |   |
|--|---|---|
| EN 61000-4-2:1995 + A1:98<br>IEC 61000-4-2:1995 + A1:98<br>EN 60801-1:1993<br>IEC 801.2:1991<br>IEC 801.2:1984 | EN 61000-4-3:1996 + A1:98<br>IEC 61000-4-3:1995 + A1:98<br>IEC 801.3:1984<br>ENV 50140:1993 +<br>ENV 50204:1995 | EN 61000-4-4:1995<br>IEC 61000-4-4:1995<br>IEC 801.4:1990 |
| EN 61000-4-5:1995<br>IEC 61000-4-5:1995<br>ENV 50142:1994  | EN 61000-4-6:1996<br>IEC 61000-4-6:1996<br>ENV 50141:1993   | EN 61000-4-8:1993<br>IEC 61000-4-8:1993                   |
| EN 61000-4-11:1994<br>IEC 61000-4-11:1994  |   |   |

Oslo, 28 November 2002

Kjell Bergh, Nemko Group EMC Co-ordinator