

HomeTek Technology Inc.

ADDRESS: No. 67-9, Shir Men Road, Tu Cheng City,
Taipei Hsien, Taiwan, R. O. C.

PHONE : 886-2-22608375 FAX : 886-2-22748013

E - mail : hometek@ms15.hinet.net

FCC TEST REPORT FOR

APPLICANT : SMART CABLING & TRANSMISSION CORP.
 ADDRESS : 7F-1, NO. 168, LIEN CHENG RD.,
CHUNG-HO CITY, TAIPEI HSIEN, TAIWAN, R. O. C.
 EUT : Converter
 MODEL NO. : RS0XX



NVLAP Lab Code:200331-0

Accredited by the National Voluntary Laboratory Accreditation Program
for the specific scope of accreditation under Lab Code 200331-0

MEASUREMENT PROCEDURE USED

FCC RULES AND CISPR 22 (DOCKET NO. 92-152, SEP. 1993) AND FCC / ANSI C63.4-2001

PREPARED BY :

HomeTek Technology Inc.

No. 67-9, Shir Men Road, Tu Cheng City,

Taipei Hsien. Taiwan, R. O. C.

Report # : FD3L029



TABLE OF CONTENTS.....2

VERIFICATION.....3

GENERAL INFORMATION.....4

MODIFICATION LIST.....5

CONDUCTED POWER LINE TEST.....6

 1 TEST PROCEDURE.....6

 2 RESULT OF CONDUCTED EMISSION TEST6

RADIATED EMISSION TEST.....7

 1 TEST INSTRUMENTS & FACILITIES7

 2 TEST PROCEDURE.....8

 3 TEST SETUP8

 4 CONFIGURATION OF THE EUT.....10

 5 EUT OPERATING CONDITION.....13

 6 LIMIT OF RADIATED EMISSION CLASS B13

 7 RESULT OF RADIATED EMISSION TEST14

 8 RADIATED EMISSION TEST DATA (PAGE 1).....15

 9 RADIATED EMISSION TEST DATA (PAGE 2).....16

SAMPLE OF FCC LABEL..... 17

APPENDIX A

PHOTOS OF TEST CONFIGURATION

APPENDIX B

PHOTOS OF EUT



ADDRESS: No. 67-9, Shir Men Road, Tu Cheng City,
 Taipei Hsien, Taiwan, R. O. C.
 PHONE : 886-2-22608375 FAX : 886-2-22748013
 E - mail : hometek@ms15.hinet.net

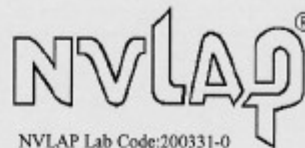

VERIFICATION

for

FCC Part 15, Subpart B Class B

APPLICANT : SMART CABLING & TRANSMISSION CORP.
 ADDRESS : 7F-1, NO. 168, LIEN CHENG RD.,
CHUNG-HO CITY, TAIPEI HSIEN, TAIWAN, R. O. C.
 Receipt Date : 12/13/2004 Final Test Date: 12/27/2004
 EUT : Converter
 MODEL NO. : RS0XX

MEASUREMENT PROCEDURE USED :

FCC RULES AND CISPR 22 (DOCKET NO. 92-152, SEP. 1993)
 AND FCC / ANSI C63.4-2001

TEST PROCEDURE AND DATA ARE TRACEABLE TO NIST/USA,
 TL or NML/TAIWAN.

- THE MAXIMUM EMISSION LEVELS WERE COMPARED TO THE CISPR 22 CLASS B LIMITS BOTH RADIATED AND CONDUCTED EMISSION.
- THE ABOVE DEVICE WAS TESTED BY HOMETEK TECHNOLOGY INC. TO SHOWS THE MAXIMUM EMISSION LEVEL FROM THE DEVICE.
- THIS TEST RESULTS OF THIS REPORT APPLIES TO ABOVE TESTED SAMPLE ONLY.
- THIS TEST REPORT SHALL NOT BE REPRODUCE IN PART WITHOUT WRITTEN APPROVAL OF HOMETEK TECHNOLOGY INC.
- THE REPORT MUST NOT BE USED BY THE CLIENT TO CLAIM PRODUCT ENDORSEMENT BY NVLAP OR ANY AGENCY OF THE U. S. GOVERNMENT.
- THE TEST RESULTS ARE TRACEABLE TO THE NATIONAL OR INTERNATIONAL STANDARD.

PREPARED BY : Ming Yu Li DATE : 1/26/2005
 MING YU LI

CHECK BY : Albert Tsai DATE : 1/26/2005
 ALBERT TSAI / Senior Engineer

APPROVED BY : Tommy Rau DATE : 1/26/2005
 TOMMY RAU / Manager



GENERAL INFORMATION

- 1 APPLICANT : SMART CABLING & TRANSMISSION CORP.
- 2 ADDRESS : 7F-1, No. 168, Lien Cheng Rd.,
Chung-Ho City, Taipei Hsien, Taiwan, R. O. C.
- 3 MANUFACTURER : SMART CABLING & TRANSMISSION CORP.
- 4 ADDRESS : 7F-1, No. 168, Lien Cheng Rd.,
Chung-Ho City, Taipei Hsien, Taiwan, R. O. C.
- 5 DESCRIPTION OF EUT :
- EUT : Converter
- FCC ID : N/A
- Model Number : RS0XX
- Serial # : N/A

5.1 The difference between series of models RS0XX is different operation system. The worst case of EMI test model is RS001 and the final test data were shown in this test report.

- 6 FEATURES OF EUT :

Please refer to user manual or product specification.



HomeTek Technology Inc.

MODIFICATION LIST

THE FOLLOWING ACCESSORIES WERE ADDED TO THE EUT DURING TESTING :

NO MODIFICATION BY HOMETEK TECHNOLOGY INC.



CONDUCTED POWER LINE TEST

1 TEST PROCEDURE

According to **ANSI C63.4 - 2001 & CISPR 22.**

2 RESULT OF CONDUCTED EMISSION TEST

N/A (Conducted Power Line Test is not applicable to this EUT (Model : RS001)).



RADIATED EMISSION TEST

1 TEST INSTRUMENTS & FACILITIES

The following test Instruments was used during the radiated emission test :

Item	Instruments /facilities	Specification	Manufacturer	Model # / S/N#	Date of Cal.
1	OPEN AREA TEST SITE	<input checked="" type="checkbox"/> OATS 3			JUL/2004
2	EMI TEST RECEIVER	20Hz ~ 26.5GHz	ROHDE & SCHWARZ	ESMI 845442/006	JAN/2004
3	PRE-AMPLIFIER	9KHz ~ 3000MHz	ADVANTEST	BB525C 90081001	SEP/2004
4	ANTENNA (BI-LOG)	25MHz ~ 2GHz	SCHAFFNER	CBL6112B S/N : 2614	MAY/2004
5	Attenuation	50 /6dB	JYE BAO	FAT-N (M-F) 001	JUL/2004
6	Cable	10m	SUHNER	RG214/U OS3-003	DEC/2004
7	Cable	14m	BELDEN	9913 OS3-001	DEC/2004
8	EMI 32 (software)	N/A	AUDIX	19991013-0923	N/A

Note : Items 1 ~ 7 were calibrated within period of 1 year.

2 TEST PROCEDURE

- 2.1 The EUT was test according to **ANSI C63.4 - 2001 & CISPR 22**.
- 2.2 The radiated test was performed at HomeTek Lab's Open Site **III**.
- 2.3 The frequency range from **30** MHz to **1** GHz, the measurement were made at **10** meters, with a BI-log antenna.

3 TEST SETUP

3.1 TEST SETUP OF OPEN SITE.

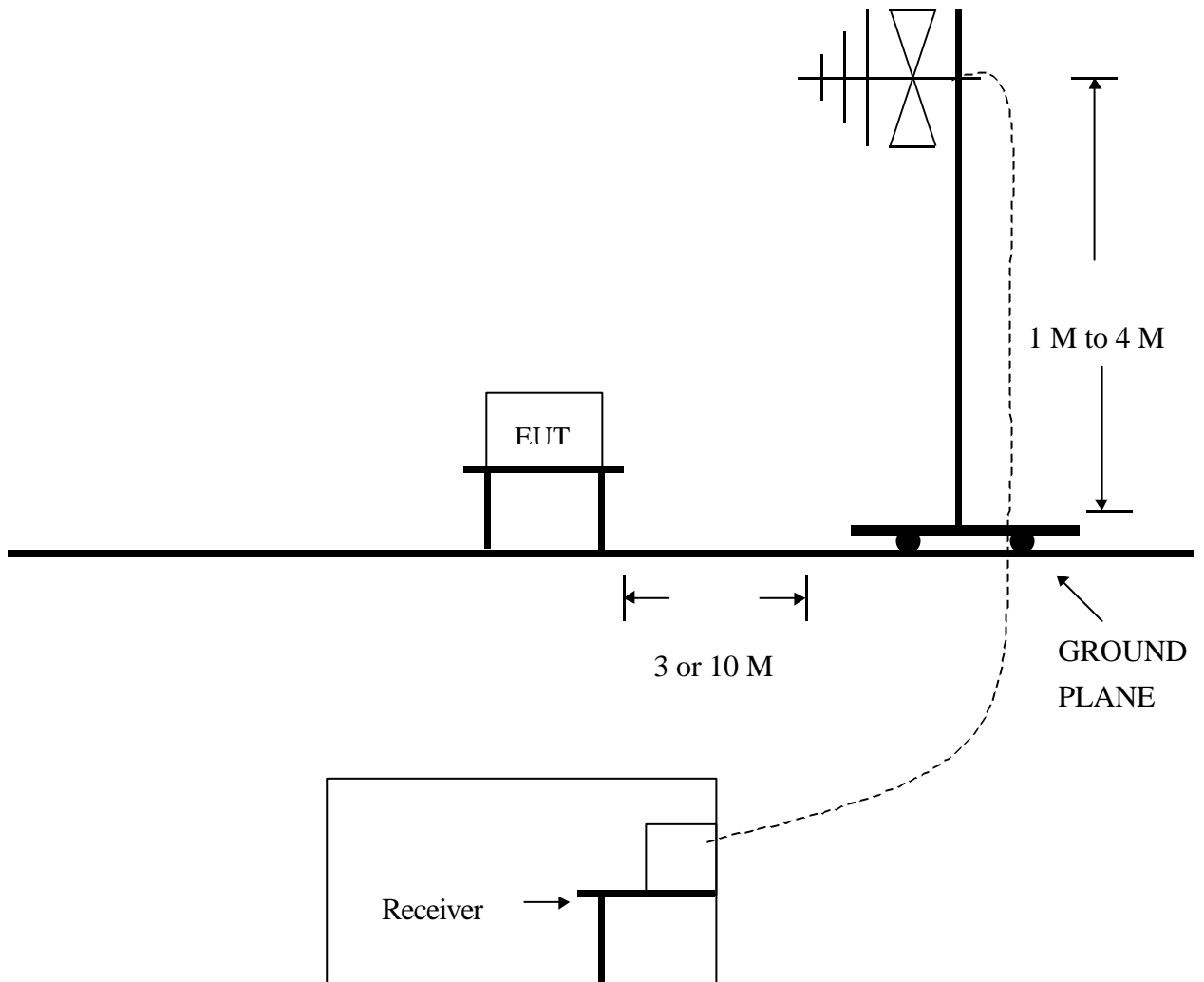

3.2 TEST SETUP OF EUT

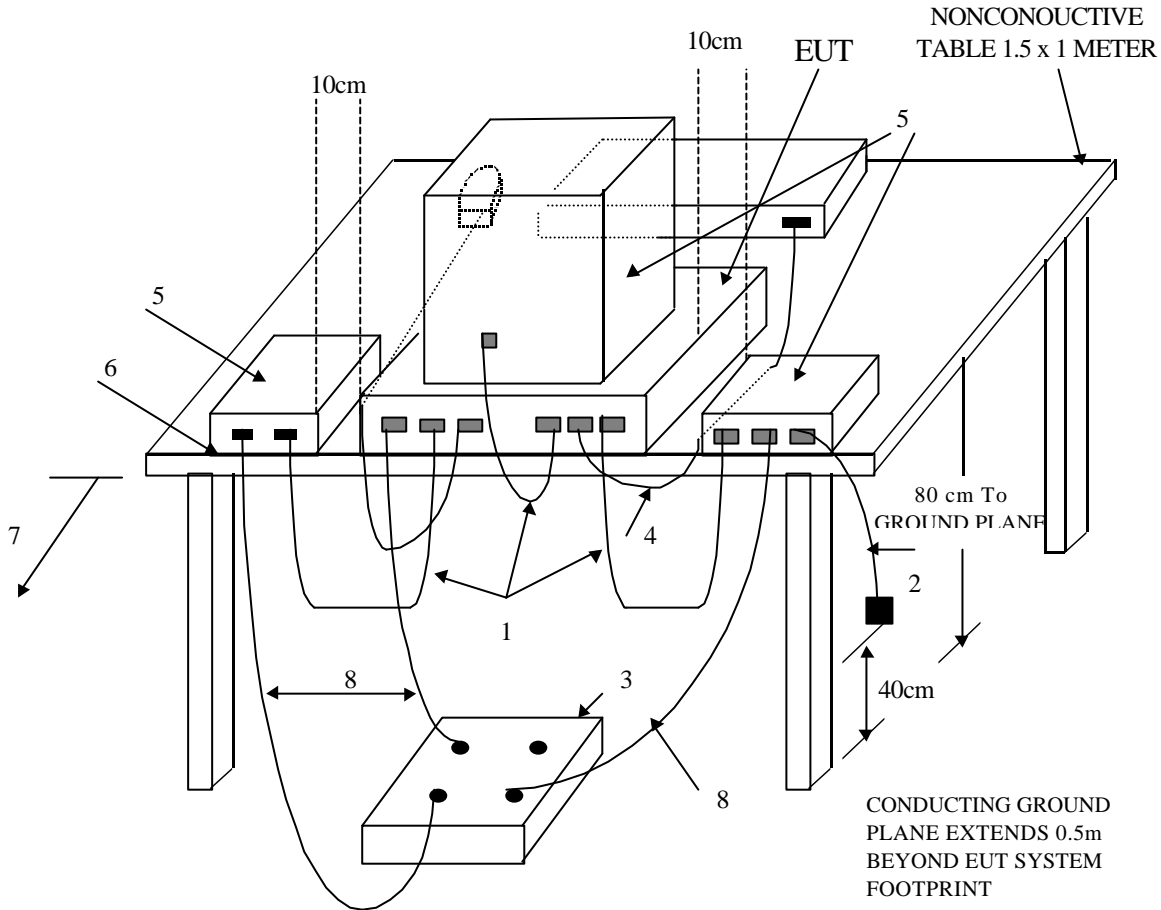

(Details for setup configuration, please refer to appendix A.)

LEGEND:

1. Interconnecting cables that hang closer than 40 cm to the ground plane shall be folded back and forth forming a bundle 30 to 40 cm long, hanging approximately in the middle between ground plane and table.
2. I/O cables that are connected to a peripheral shall be bundled in center. The end of the cable may be terminated if required using correct terminating impedance. The total length shall not exceed 1m.
3. If LISNs are kept in the test setup for radiated emissions, it is preferred that they be installed under the ground plane with the receptacle flush with the ground plane.
4. Cables of hand-operated devices, such as keyboards, mice, etc., have to be placed as close as possible to the controller.
5. Non-EUT components of EUT system being tested.
6. The rear of all components of the system under test shall be located flush with the rear of the table.
7. No vertical conducting wall used.
8. Power cords drape to the floor and are routed over to receptacle.

**Test Configuration
Tabletop Equipment Radiated Emission**

4 CONFIGURATION OF THE EUT

The EUT was configured according to **ANSI C63.4 - 2001 & CISPR 22**. All I/O ports were connected to the appropriate peripherals. All peripherals and cables are listed below (including internal device) :

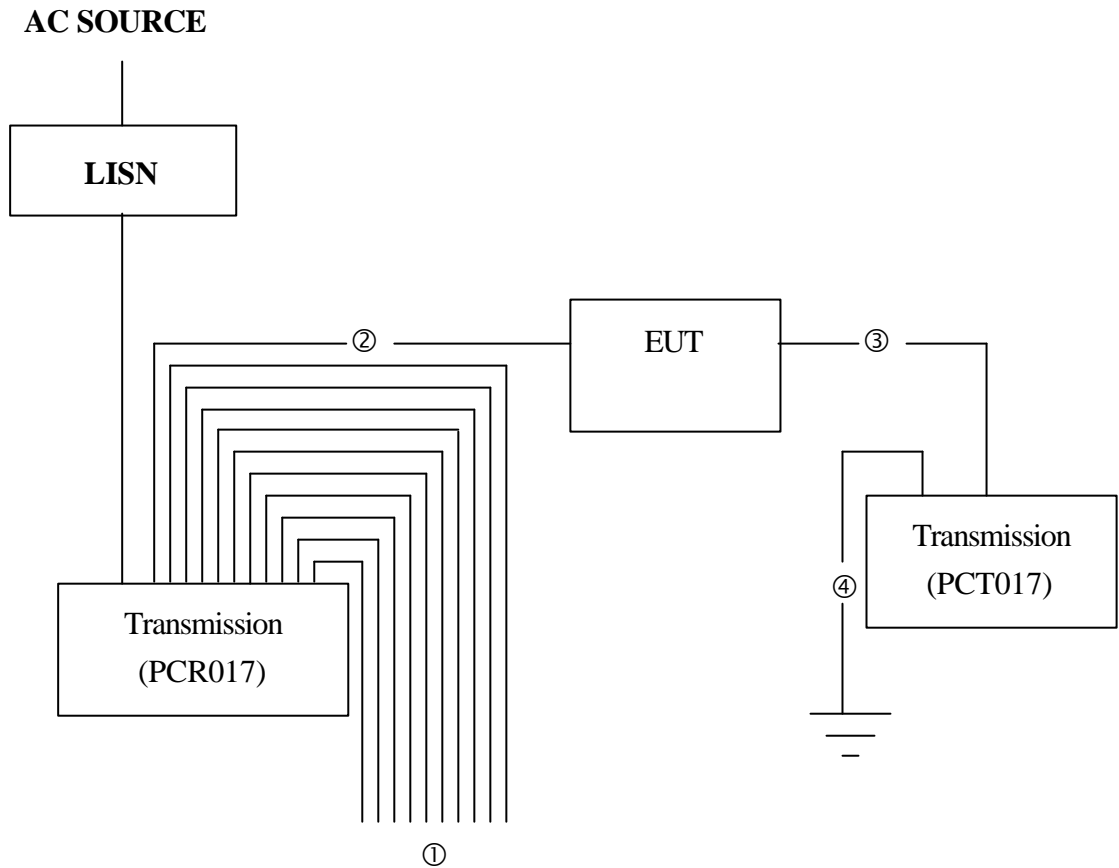

- ① *Data cable floating x10*
- ② *Twisted Pair Cable*
- ③ *Twisted Pair Cable*
- ④ *Connect to Ground*

Figure 1



4.1 EUT

EUT Type : Proto Type Engineer Type Mass Production
Condition when received : Good Damage : _____
Device : Converter
Applicant : SMART CABLING & TRANSMISSION CORP.
Manufacturer : SMART CABLING & TRANSMISSION CORP.
Model Number : RS0XX
Serial Number : N/A
FCC ID : N/A
RS485 Port : Metal Type Connector
RS232 Port : Metal Type Connector
Power Cord : N/A
Power Supply Type : N/A

4.2 PERIPHERALS

Transmission

Manufacturer : SMART CABLING & TRANSMISSION CORP.
Model Number : PCR017
Serial Number : N/A
FCC ID : N/A
Data Cable : Un-Shielded, 2.5 m, Connected to the RS485 Port
Power Cord : Un-Shielded, 1.8 m



Transmission

Manufacturer : SMART CABLING & TRANSMISSION CORP.

Model Number : PCT017

Serial Number : N/A

FCC ID : N/A

Data Cable : Un-Shielded, 0.1 m, Connected to the RS232 Port

Power Cord : Un-Shielded, 1.8 m

4.3 REMARK : N/A



5 EUT OPERATING CONDITION

- 5.1 The frequency of the EUT is none.
- 5.2 Configure the EUT according to the **ANSI C63.4 - 2001 & CISPR 22.**
- 5.3 Turn on all the power of EUT and peripheral
- 5.4 Serial port of Support Unit1(Transmission PCT017) connected with the RS232 Port of EUT via 0.1m cable
- 5.5 EUT's RS485 Port connected with the serial port of Support Unit2(Transmission PCR017) via 2.5m cable
- 5.6 Monitor the status of output port of EUT during the test (For EMS Testing)
- 5.7 The photos of conducted test configuration, please refer to appendix A.**

6 LIMIT OF RADIATED EMISSION CLASS B

CISPR 22

Frequency (MHz)	Measurement Distance	Limit (dBuV/m)
30 - 230	10 (M)	30
230 - 1000	10 (M)	37

- 6.1 The tighter limit shall apply at the edge between two frequency bands.
- 6.2 Measurement distance in meters between the measuring instrument antenna and the closed point of any part of the EUT or peripherals.



7 RESULT OF RADIATED EMISSION TEST

- 7.1 The frequency range from 30 MHz to 1 GHz was investigated.
- 7.2 All readings below or equal 1 GHz are quasi-peak or peak values with resolution bandwidth of 120 KHz.
- 7.3 All readings above 1 GHz are average or peak values with resolution bandwidth of 1 MHz
- 7.4 The measurements were made at 10 meters of HomeTek Lab's open site III.
- 7.5 Temperature : 33 , Humidity : 55 % RH.
- 7.6 Deviation form the test standards and rules : None
- 7.7 The radiation emission result were gained by the following method :
Level = Reading Level + Probe Factor (Antenna Factor) + Cable Loss – Preamp Factor
Over Limit = Level – Limit Line
- 7.8 The radiated mission test was passed at minimum margin :
Vertical 60.30 MHz/ 26.51 dBuV/m, Antenna Height 1.1 Meter,
Turn Table 138 degree, Model : RS001.
- 7.9 Result : **PASSED**



HomeTek Technology Inc.

No 67-9, Shi-Men Rd., Tu-Chen City, Taipei County, Taiwan R.O.C.
Tel: 02-22608375
Fax: 02-22748013

Data#: 3 File#: 31029.emi

Date: 2004-12-15 Time: 16:58:28

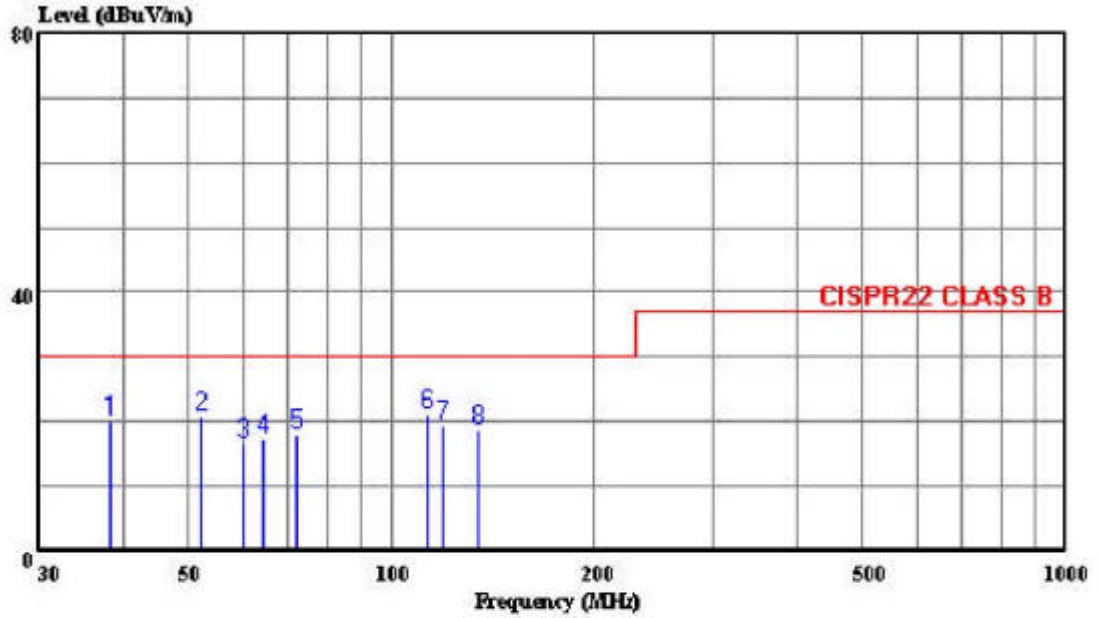

Trace:

Ref Trace:

Condition: CISPR22 CLASS B 10m CHASE 2614 052604 HORIZONTAL
cut : Converter
power: 110V/60Hz
memo : RS001

Page: 1

	Freq	Level	Limit	Over	ReadAntenna	Cable	Preamp		
	MHz	dBuV/m	dBuV/m	dB	Level	Loss	Factor	Remark	
					Factor	Factor			
					dB/m	dB	dB		
1	38.273	20.04	30.00	-9.96	35.82	13.17	0.94	29.89	Peak
2	52.260	20.69	30.00	-9.31	42.40	7.01	1.12	29.83	Peak
3	60.307	16.74	30.00	-13.26	39.58	5.68	1.17	29.70	Peak
4	64.253	17.17	30.00	-12.83	39.96	5.64	1.20	29.64	Peak
5	72.493	18.08	30.00	-11.92	40.27	6.04	1.27	29.50	Peak
6	112.507	21.14	30.00	-8.86	37.17	11.55	1.53	29.11	Peak
7	118.800	19.41	30.00	-10.59	35.32	11.68	1.56	29.15	Peak
8	134.220	19.78	30.00	-11.22	35.34	11.04	1.64	29.24	Peak



9 RADIATED EMISSION TEST DATA (PAGE 2)



HomeTek Technology Inc.

No 67-9, Shi-Men Rd., Tu-Chen City, Taipei County, Taiwan R.O.C.
Tel:02-22608375
Fax:02-22748013

Data#: 4 File#: 31029.emi

Date: 2004-12-15 Time: 17:20:49

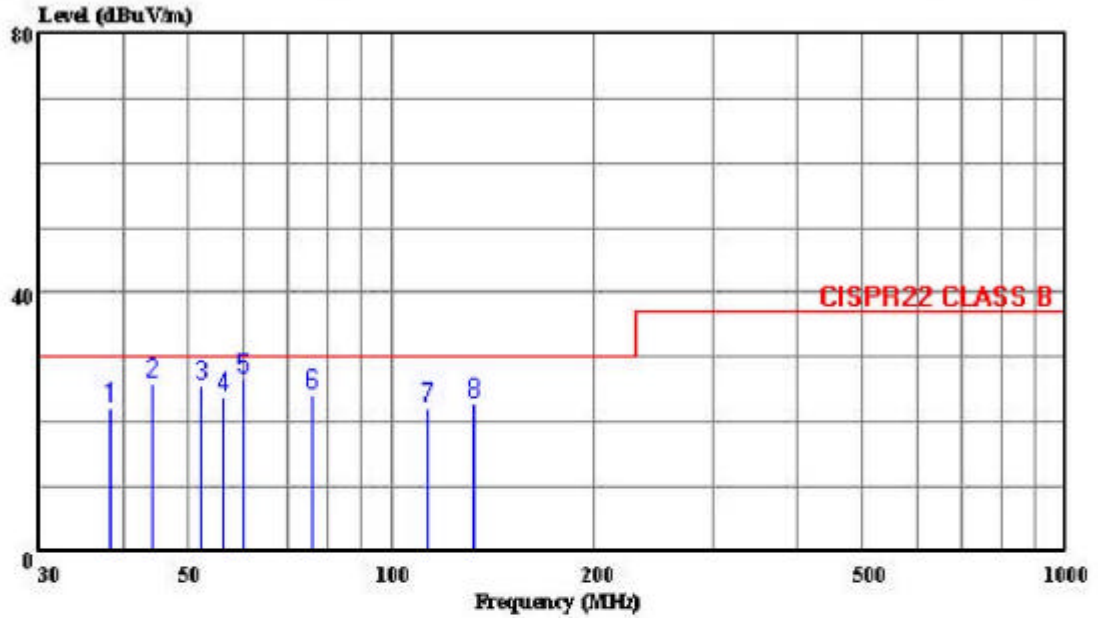

Trace:

Ref Trace:

Condition: CISPR22 CLASS B 10m CHASE 2614 052604 VERTICAL
cut : Converter
power: 110V/60Hz
memo : RS001

Page: 1

	Freq	Level	Limit	Over	ReadAntenna	Cable	Preamp	
	MHz	dBuV/m	dBuV/m	Limit	Level	Factor	Loss	Factor
				dB	dBuV	dB/m	dB	dB
1	38.244	22.33	30.00	-7.67	38.11	13.17	0.94	29.89
2	44.311	26.06	30.00	-3.92	44.05	10.89	1.03	29.89
3	52.262	25.72	30.00	-4.28	47.43	7.01	1.12	29.83
4	56.289	23.77	30.00	-6.23	46.18	6.21	1.14	29.77
5	60.304	26.51	30.00	-3.49	49.35	5.68	1.17	29.70
6	76.420	24.37	30.00	-5.63	46.03	6.48	1.29	29.43
7	112.538	22.20	30.00	-7.80	38.23	11.55	1.53	29.11
8	132.631	22.95	30.00	-7.05	39.39	11.16	1.63	29.23



SAMPLE OF FCC LABEL

This device complies with part 15 of the FCC Rules.
Operation is subject to the following two conditions: (1)
This device may not cause harmful interference. And (2)
this device must accept any interference received, including
interference that may cause undesired operation.



HomeTek Technology Inc.

Appendix A
PHOTOS OF TEST CONFIGURATION

PHOTO OF RADIATED EMISSION TEST

Model : RS001

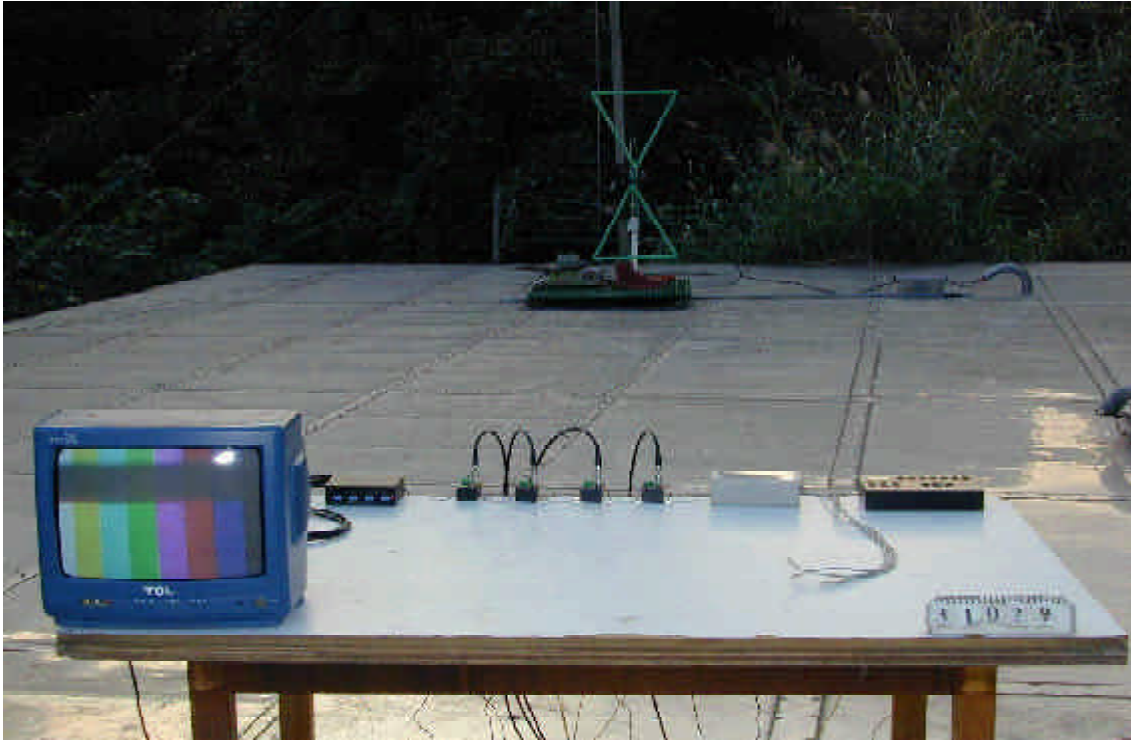

Front View

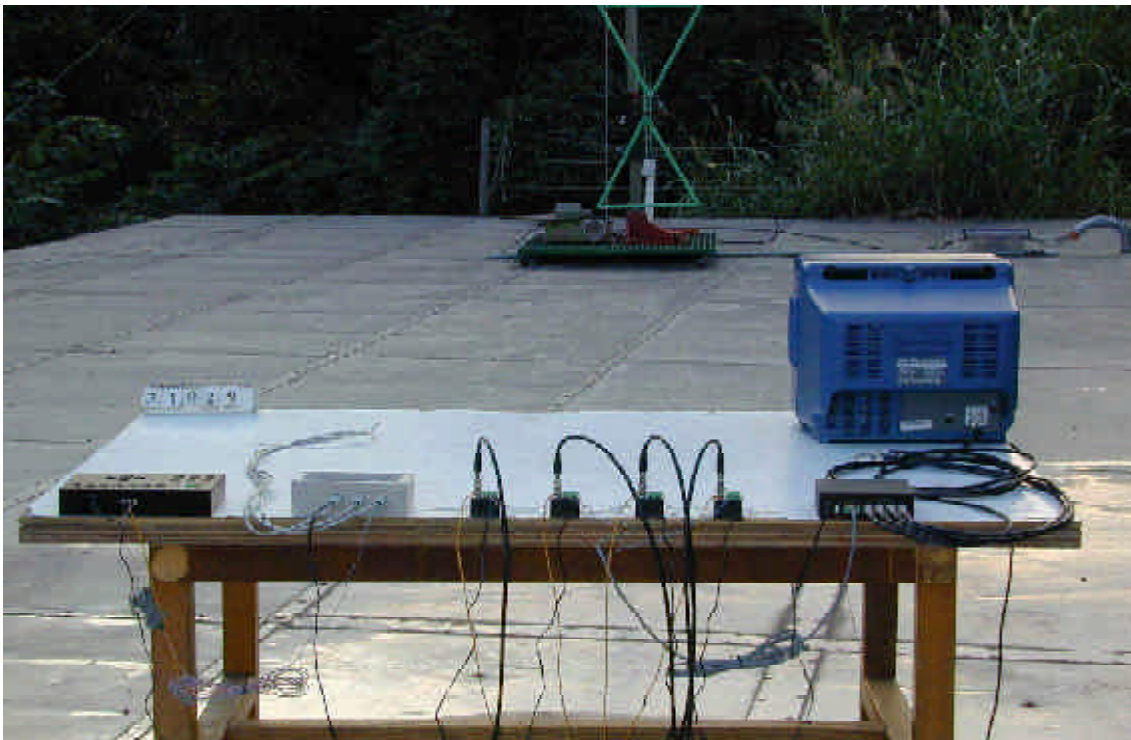

Rear View



HomeTek Technology Inc.

Appendix B
PHOTOS OF EUT

PHOTO OF EUT

Model : RS001

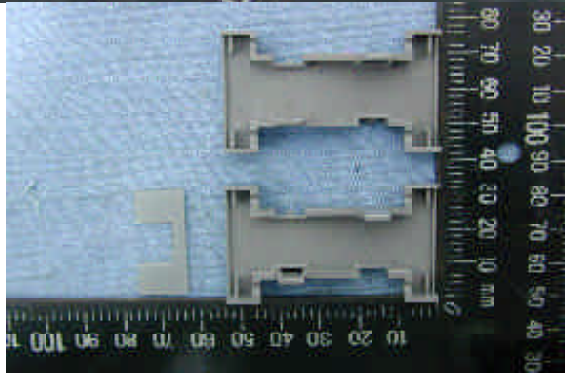
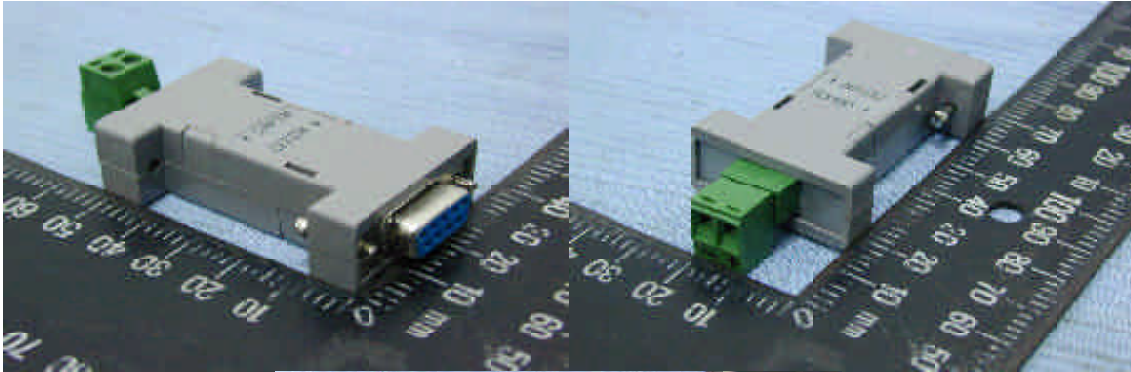

Full View of EUT

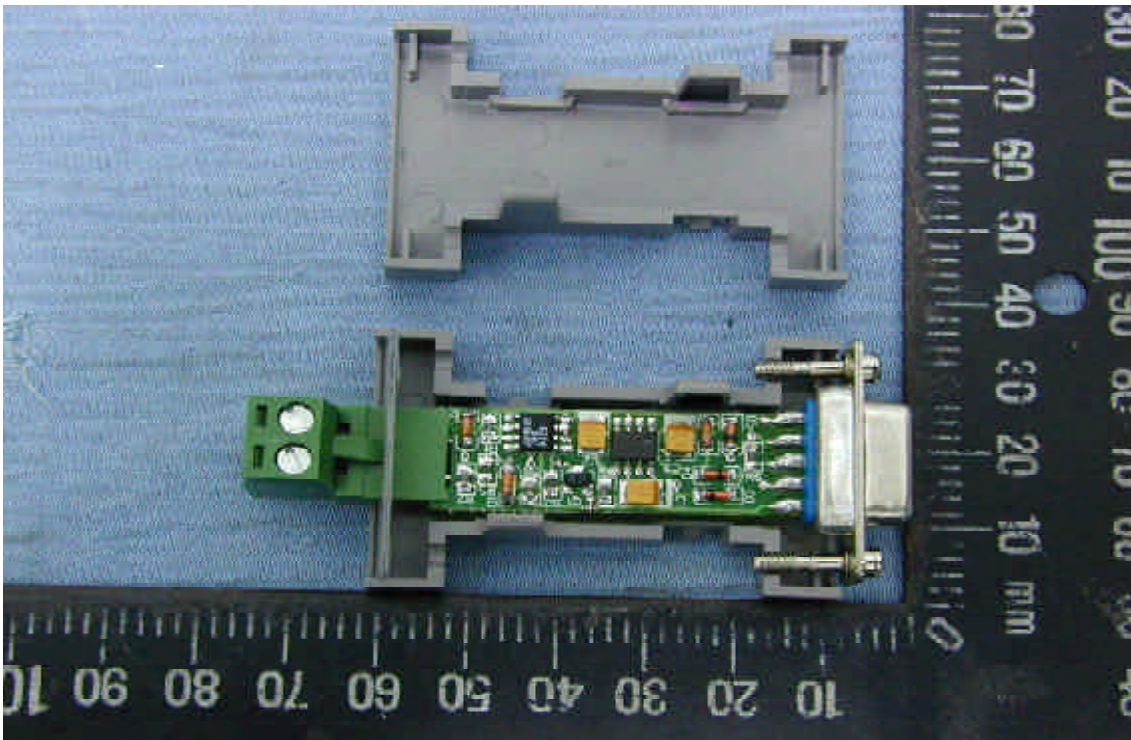

Inside View of EUT

PHOTO OF EUT

Model : RS001

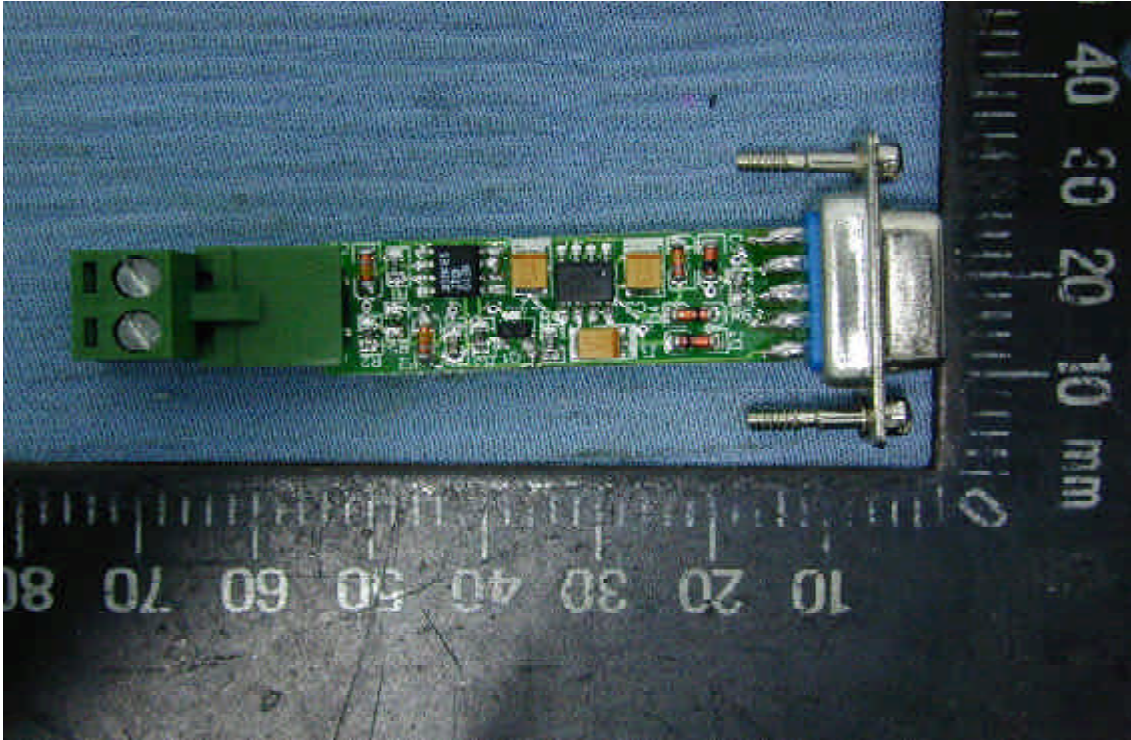

Component Side of Main Board

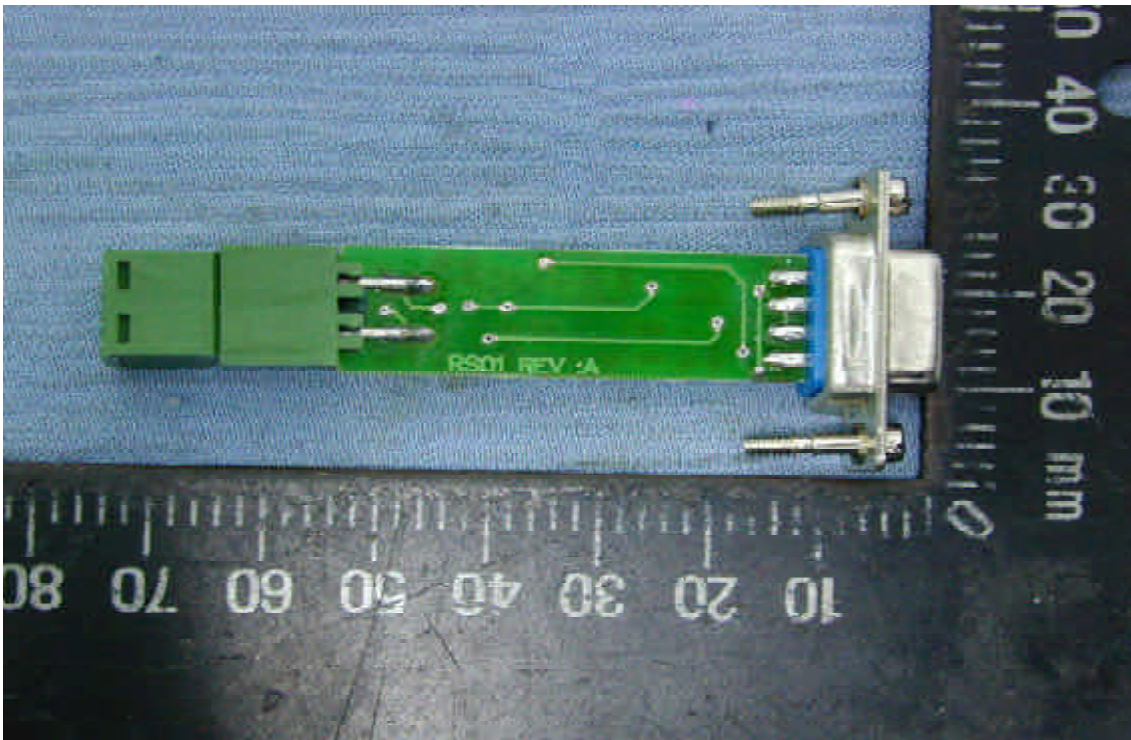

Solder Side of Main Board

United States Department of Commerce
National Institute of Standards and Technology

NVLAP®

ISO/IEC 17025:1999
ISO 9002:1994

Certificate of Accreditation



HOMETEK TECHNOLOGY INC.

TAIPEI SHIEN 236
TAIWAN

*is recognized by the National Voluntary Laboratory Accreditation Program
for satisfactory compliance with criteria set forth in NIST Handbook 150:2001,
all requirements of ISO/IEC 17025:1999, and relevant requirements of ISO 9002:1994.
Accreditation is awarded for specific services, listed on the Scope of Accreditation, for:*

ELECTROMAGNETIC COMPATIBILITY AND TELECOMMUNICATIONS

September 30, 2005

Effective through

A handwritten signature in black ink, appearing to read "Stephen P. Madl".

For the National Institute of Standards and Technology
NVLAP Lab Code: 200331-0

Scope of Accreditation



ELECTROMAGNETIC COMPATIBILITY AND TELECOMMUNICATIONS

NVLAP LAB CODE 200331-0

HOMETEK TECHNOLOGY INC.

P.O Box: 13-131, Pan-Chiao City
No. 67-9 Shir Men Rd., Tu Chen City
Taipei Shien 236
TAIWAN

Mr. Grant Huang

Phone: 886-2-22608375 Fax: 886-2-22748013

E-Mail: hometek@ms15.hinet.net

NVLAP Code Designation / Description

Emissions Test Methods:

12/CIS22	IEC/CISPR 22 (1997) & EN 55022 (1998) + A1(2000): Limits and methods of measurement of radio disturbance characteristics of information technology equipment
12/CIS22a	IEC/CISPR 22 (1993) and EN 55022 (1994): Limits and methods of measurement of radio disturbance characteristics of information technology equipment, Amendment 1 (1995) and Amendment 2 (1996)
12/CIS22b	CNS 13438 (1997): Limits and Methods of Measurement of Radio Interference Characteristics of Information Technology Equipment
12/FCC15b	ANSI C63.4 (2001) with FCC Method 47 CFR Part 15, Subpart B: Unintentional Radiators

September 30, 2005

Effective through

For the National Institute of Standards and Technology

National Institute
of Standards and Technology



National Voluntary
Laboratory Accreditation Program

ISO/IEC 17025:1999
ISO 9002:1994

Scope of Accreditation



Page: 2 of 2

**ELECTROMAGNETIC COMPATIBILITY
AND TELECOMMUNICATIONS**

NVLAP LAB CODE 200331-0

HOMETEK TECHNOLOGY INC.

NVLAP Code Designation / Description

12/T51 AS/NZS CISPR 22 (2002) and AS/NZS 3548 (1997): Electromagnetic Interference -
Limits and Methods of Measurement of Information Technology Equipment

September 30, 2005

Effective through

A handwritten signature in black ink, appearing to read 'William R. Miel'.

For the National Institute of Standards and Technology