

ADDRESS: No. 67-9, Shir Men Road, Tu Cheng City,  
Taipei Hsien, Taiwan  
PHONE : 886-2-22608375 FAX : 886-2-22748013  
E - mail : hometek@ms15.hinet.net

## CE TEST REPORT FOR

APPLICANT : SMART CABLING & TRANSMISSION CORP.  
ADDRESS : 10F, No. 493, Chung-Cheng Rd.,  
Hsin Tien City, Taipei 231, Taiwan, R. O. C.  
Receipt Date : 12/13/2004 Final Test Date: 12/20/2004  
EUT : Twisted Pair Transmission  
MODEL NO. : TTA111XXX

### MEASUREMENT PROCEDURE USED

EN 61000-6-3 / EN61000-3-2 / EN61000-3-3 / EN 50130-4 CLASS B GIVEN IN  
EUROPEAN COUNCIL DIRECTIVE 2004/108/EC

This test result of this report applies to above tested sample only.

This test report shall not be reproducing in part without written approval of HomeTek Technology Inc.

### PREPARED BY :

HomeTek Technology Inc.

No. 67-9, Shir Men Road, Tu Cheng City,

Taipei Hsien. Taiwan

Report # : EB6G011

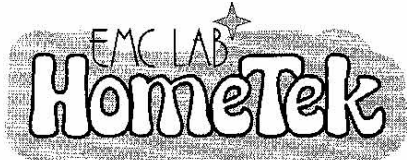

HomeTek Technology Inc.

ADDRESS: No. 67-9, Shir Men Road, Tu Cheng City,  
Taipei Hsien, Taiwan, R. O. C.

PHONE : 886-2-22608375 FAX : 886-2-22748013

E - mail : hometek@ms15.hinet.net

# CERTIFICATE OF COMPLIANCE

EUT : Twisted Pair Transmission

MODEL NO. : TTA111XXX

Receipt Date : 12/13/2004 Final Test Date: 12/20/2004

REPORT # : EB6G011

APPLICANT : SMART CABLING & TRANSMISSION CORP.

ADDRESS : 10F, No. 493, Chung-Cheng Rd.,  
Hsin Tien City, Taipei 231, Taiwan, R. O. C.

Measurement procedure used:

- EMI: EN 61000-6-3 (2001): CISPR 22 Class B (1997),  
EN 61000-3-2 (2000), EN 61000-3-3 (1995) + A1 (2001)
- EMS: EN 50130-4 (1995) + A1 (1998) + A2 (2003):  
IEC 61000-4-2 (2001), IEC 61000-4-3 (2002), IEC 61000-4-4 (2004),  
IEC 61000-4-5 (2001), ENV 50141 (1993), IEC 61000-4-11 (2004)

We hereby show that:

The measurements shown in this test report were made in accordance with the procedures given in **EUROPEAN COUNCIL DIRECTIVE 2004/108/EC**, and the energy emitted by the equipment was found to be within the limits applicable. This product, which has been issued the test report listed as above in HomeTek Technology Inc., is based on single evaluation of one sample and confirmed to comply with the requirements of the above-mentioned EMC standard.

This test report is modified from original one (Report No. EB3L026, issued on 2005, 01, 26), test standard is updated.

APPROVED BY :  7/31/2007

ALAIN LIN / Supervisor



## DESCRIPTION OF UPGRADE OF TEST STANDARDS

Applicant: SMART CABLING & TRANSMISSION CORP.

Product Name: Twisted Pair Transmission

Model Number: TTA111XXX

The test standard of this report (No. EB6G011) is updated from original one (No. EB3L026) with the procedures given in **EUROPEAN COUNCIL DIRECTIVE 2004/108/EC** and the measurement procedure used **EN 61000-6-3 (2001): CISPR 22 Class B (1997) / EN 61000-3-2 (2000) / EN 61000-3-3 (1995) + A1 (2001) / EN 50130-4 (1995) + A1 (1998) + A2 (2003): IEC 61000-4-2 (2001), IEC 61000-4-3 (2002), IEC 61000-4-4 (2004), IEC 61000-4-5 (2001), ENV 50141 (1993), IEC 61000-4-11 (2004)**. According to EUT's specification and operation manual, the test procedures of new version of standards are applied to EUT. Thus, we HomeTek issue a new certificate with new version of test standard.

HomeTek Inc.

31, July 2007

ALAIN LIN / Supervisor

**TEST REPORT CERTIFICATION**

**EMC of electrical appliances**

Report reference No. : EB6G011  
Date of issue : JULY, 31, 2007  
Applicant : SMART CABLING & TRANSMISSION CORP.  
Address : 10F, No. 493, Chung-Cheng Rd.,  
Hsin Tien City, Taipei 231, Taiwan, R. O. C.  
Manufacturer : SMART CABLING & TRANSMISSION CORP.  
Type of test object : Twisted Pair Transmission  
Model/type reference : TTA111XXX  
Test Result : Complied  
Testing laboratory : HomeTek Technology Inc.  
Address : No. 67-9, Shir Men Road, Tu Cheng City, Taipei Hsien,  
Taiwan, R. O. C.  
TEL / FAX : +886-2-22608375 / +886-2-22748013  
E-mail : hometek@ms15.hinet.net  
Standard : EN 61000-6-3 (2001): CISPR 22 Class B (1997),  
EN 61000-3-2 (2000), EN 61000-3-3 (1995) + A1 (2001),  
EN 50130-4 (1995) + A1 (1998) + A2 (2003):  
IEC 61000-4-2 (2001), IEC 61000-4-3 (2002),  
IEC 61000-4-4 (2004), IEC 61000-4-5 (2001),  
ENV 50141 (1993), IEC 61000-4-11 (2004)

Tested by (+ signature) :  
*Chad Huang / Engineer*

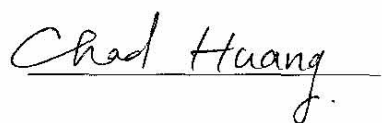

Approved by (+ signature) :  
*Alain Lin / Supervisor*





**DESCRIPTION OF UPGRADE OF TEST STANDARDS ..... 1**

**TEST REPORT CERTIFICATION..... 2**

**TABLE OF CONTENTS..... 3**

**GENERAL INFORMATION..... 6**

**MODIFICATION LIST..... 8**

**CONDUCTED POWER LINE TEST ..... 9**

1 TEST INSTRUMENTS & FACILITIES..... 9

2 TEST PROCEDURE..... 9

3 TEST SETUP ..... 10

4 CONFIGURATION OF THE EUT ..... 12

5 EUT OPERATING CONDITION..... 16

6 LIMIT OF CONDUCTED POWER LINE EMISSION CLASS B..... 16

7 RESULT OF CONDUCTED POWER LINE TEST..... 16

8 CONDUCTED POWER LINE TEST DATA (PAGE 1)..... 17

9 CONDUCTED POWER LINE TEST DATA (PAGE 2)..... 18

10 CONDUCTED POWER LINE TEST DATA (PAGE 3)..... 19

11 CONDUCTED POWER LINE TEST DATA (PAGE 4)..... 20

**RADIATED EMISSION TEST..... 21**

1 TEST INSTRUMENTS & FACILITIES..... 21

2 TEST PROCEDURE..... 22

3 TEST SETUP ..... 22

4 CONFIGURATION OF THE EUT ..... 23

5 EUT OPERATING CONDITION..... 23

6 LIMIT OF RADIATED EMISSION CLASS B ..... 23

7 RESULT OF RADIATED EMISSION TEST..... 23

8 RADIATED EMISSION TEST DATA (PAGE 1)..... 24

9 RADIATED EMISSION TEST DATA (PAGE 2)..... 25

**HARMONICS TEST..... 26**

1 TEST INSTRUMENTS & FACILITIES..... 26

2 TEST PROCEDURE..... 26

3 TEST SETUP ..... 26

4 CONFIGURATION OF THE EUT ..... 26

5 OPERATION CONDITION OF EUT..... 26

6 TEST DATA & LIMIT..... 26

7 PHOTOS OF TEST CONFIGURATION PLEASE REFER TO APPENDIX A..... 26

8 HARMONICS TEST DATA (PAGE 1~2)..... 27

**VOLTAGE FLUCTUATIONS TEST ..... 29**

1 TEST INSTRUMENTS & FACILITIES..... 29



2 TEST PROCEDURE..... 29

3 TEST SETUP ..... 29

4 CONFIGURATION OF THE EUT ..... 29

5 OPERATION CONDITION OF EUT ..... 29

6 TEST DATA & LIMIT ..... 29

7 PHOTOS OF TEST CONFIGURATION PLEASE REFER TO APPENDIX A. .... 29

8 VOLTAGE FLUCTUATIONS TEST DATA (PAGE 1) ..... 30

**ELECTROSTATIC DISCHARGE IMMUNITY TEST (ESD) ..... 31**

1 TEST INSTRUMENTS & FACILITIES..... 31

2 TEST PROCEDURE..... 31

3 TEST SETUP ..... 31

4 CONFIGURATION OF THE EUT ..... 32

5 EUT OPERATION CONDITION..... 32

6 TEST CONDITION ..... 32

7 PERFORMANCE CRITERIA ..... 32

8 TEST RESULT ..... 33

**RADIO FREQUENCY ELECTROMAGNETIC FIELD IMMUNITY TEST (RF)..... 34**

1 TEST INSTRUMENTS & FACILITIES..... 34

2 TEST PROCEDURE..... 34

3 TEST SETUP ..... 35

4 CONFIGURATION OF THE EUT ..... 36

5 OPERATION CONDITION OF EUT ..... 36

6 TEST CONDITION ..... 36

7 PERFORMANCE CRITERIA ..... 36

8 TEST RESULT ..... 37

**ELECTRICAL FAST TRANSIENT/BURST IMMUNITY TEST (EFT)..... 38**

1 TEST INSTRUMENTS & FACILITIES..... 38

2 TEST PROCEDURE..... 38

3 TEST SETUP ..... 38

4 CONFIGURATION OF THE EUT ..... 39

5 OPERATION CONDITION OF EUT ..... 39

6 TEST CONDITION ..... 39

7 PERFORMANCE CRITERIA ..... 39

8 TEST RESULT ..... 40

**SURGE IMMUNITY TEST ..... 41**

1 TEST INSTRUMENTS & FACILITIES..... 41

2 TEST PROCEDURE..... 41

3 TEST SETUP ..... 41

4 TEST LEVELS..... 42



5 CONFIGURATION OF THE EUT ..... 42

6 EUT OPERATION CONDITION..... 42

7 CONDITIONS DURING TESTING..... 43

8 PERFORMANCE CRITERIA ..... 43

9 TEST RESULT ..... 44

**IMMUNITY TEST TO CS CONDUCTED DISTURBANCE ..... 45**

1 TEST INSTRUMENTS & FACILITIES..... 45

2 TEST PROCEDURE..... 45

3 TEST SETUP ..... 46

4 TEST LEVELS..... 47

5 CONFIGURATION OF THE EUT ..... 47

6 EUT OPERATION CONDITION..... 47

7 CONDITIONS DURING TESTING..... 47

8 PERFORMANCE CRITERIA ..... 48

9 TEST RESULT ..... 48

**VOLTAGE DIPS, SHORT INTERRUPTIONS IMMUNITY TEST AND MAIN SUPPLY VARIATIONS ..... 49**

1 TEST INSTRUMENTS & FACILITIES..... 49

2 TEST PROCEDURE..... 49

3 TEST SETUP ..... 49

4 TEST LEVELS FOR DIPS..... 50

5 CONFIGURATION OF THE EUT ..... 50

6 EUT OPERATION CONDITION..... 50

7 CONDITIONS DURING TESTING..... 50

8 PERFORMANCE CRITERIA ..... 51

9 TEST RESULT ..... 51

10 TEST LEVELS FOR MAIN SUPPLY VARIATIONS ..... 52

11 PERFORMANCE CRITERIA ..... 52

12 TEST RESULT ..... 52

**APPENDIX A**

PHOTOS OF TEST CONFIGURATION

**APPENDIX B**

PHOTOS OF EUT

## GENERAL INFORMATION

- 1 APPLICANT : SMART CABLING & TRANSMISSION CORP.
- 2 ADDRESS : 10F, No. 493, Chung-Cheng Rd.,  
Hsin Tien City, Taipei 231, Taiwan, R. O. C.
- 3 MANUFACTURER : SMART CABLING & TRANSMISSION CORP.
- 4 ADDRESS : 10F, No. 493, Chung-Cheng Rd.,  
Hsin Tien City, Taipei 231, Taiwan, R. O. C.
- 5 DESCRIPTION OF EUT :
- EUT : Twisted Pair Transmission
- Model : TTA111XXX
- Serial # : N/A

5.2 The difference between series of models TTA111XXX is shown as below:

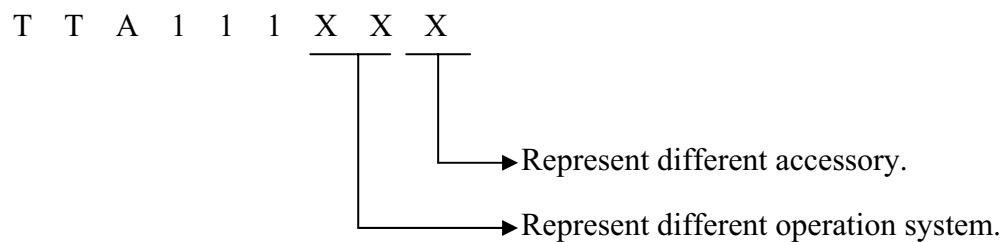

The worst case of EMC test model is TTA111VT and the final test data were shown in this test report.



6 FEATURES OF EUT :

**Please refer to user manual or product specification.**



HomeTek Technology Inc.

## **MODIFICATION LIST**

THE FOLLOWING ACCESSORIES WERE ADDED TO THE EUT DURING TESTING :

NO MODIFICATION BY HOMETEK TECHNOLOGY INC.

## CONDUCTED POWER LINE TEST

### 1 TEST INSTRUMENTS & FACILITIES

The following test Instruments was used during the conducted test :

Item	Instruments/ Facilities	Specification	Manufacturer	Model #	Date Of Cal.
1	EMI Receiver	9KHz ~ 30MHz	ROHDE & SCHWARZ	ESHS 30 844827/007	MAR/2004
2	LISN (for EUT)	50Ω/50uH/100A 150KHz ~ 30MHz	SCHWARZ BECK	NNLK 8121 8121370	OCT/2004
3	LISN (for Support Unit)	50Ω/50uH/10A 9KHz ~ 30MHz	ROHDE & SCHWARZ	ESH3-Z5 846128/007	FEB/2004
4	Terminator	50Ω	N/A	N/A	NOV/2004
5	Attenuation	50Ω/10dB	Mini-Circuit	NAT-10 AT-002	JUL/2004
6	Cable	5.4m	SUHNER	RG-223 CON2-002	AUG/2004
7	ESXS-K1 (software)	Version 2.03b 9KHz ~ 30MHz	ROHDE & SCHWARZ	1082.9678.02 840.913/246	N/A

Note : Items 1 ~ 6 were calibrated within period of 1 year.

### 2 TEST PROCEDURE

- 2.1 The EUT was tested according to **EN 61000-6-3**.
- 2.2 The EUT was placed 0.4 meter from the conducting wall of shielding room and kept at least 0.8 meter from any other grounded conducting surface.
- 2.3 The frequency range form 0.15 MHz to 30 MHz was investigated.
- 2.4 The LISN used was 50 Ohm / 50 uHenry as specified by **CISPR 22 Class B**.
- 2.5 All the support peripherals are connect to the other LISN.
- 2.6 Cables and peripherals were moved to find the maximum emission levels for each frequency.

### 3 TEST SETUP

#### 3.1 Typical : Setup Of Conducted Test

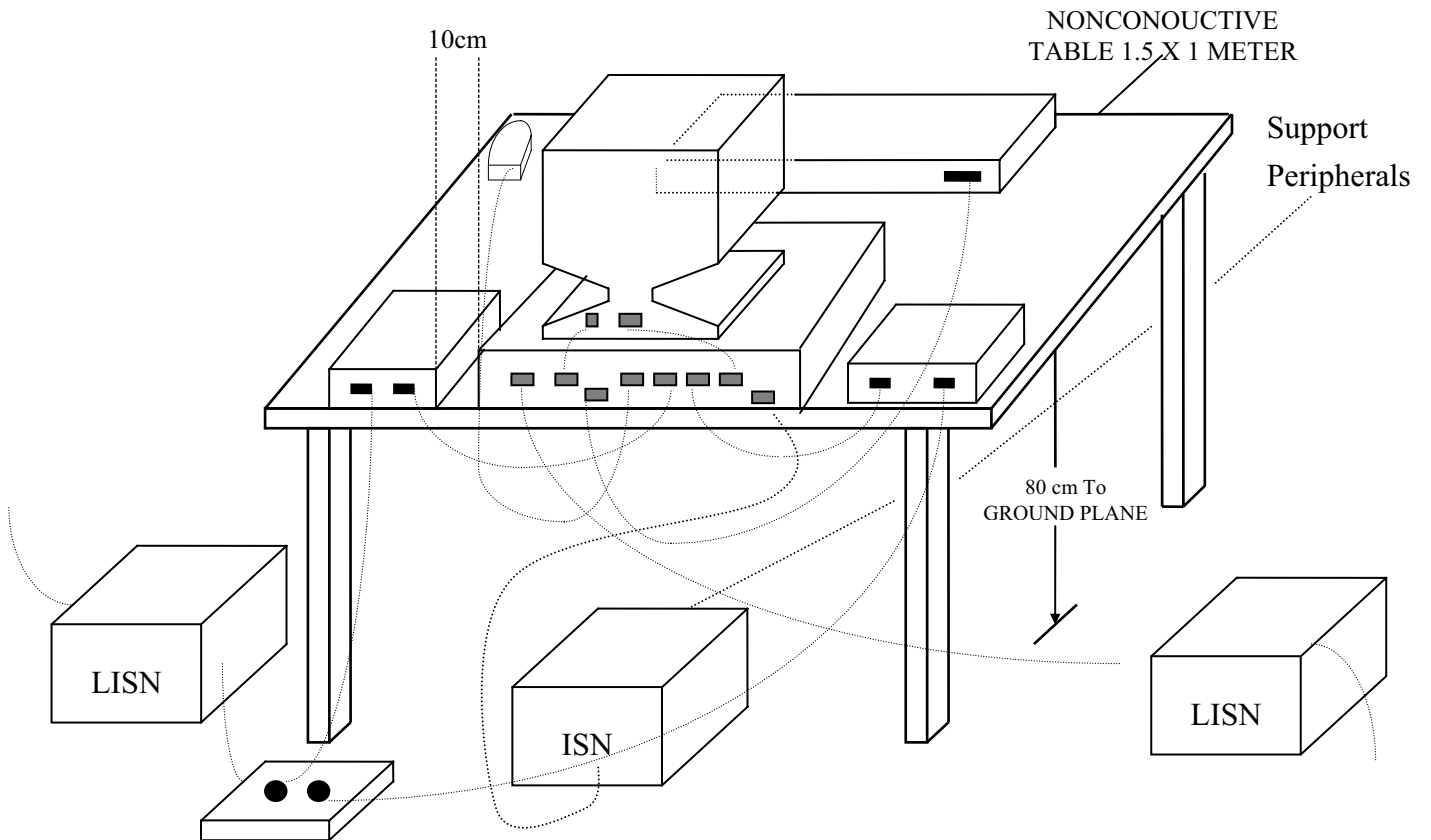

(Details for setup configuration, please refer to appendix A.)

### 3.2 Block Diagram Of Conducted Test

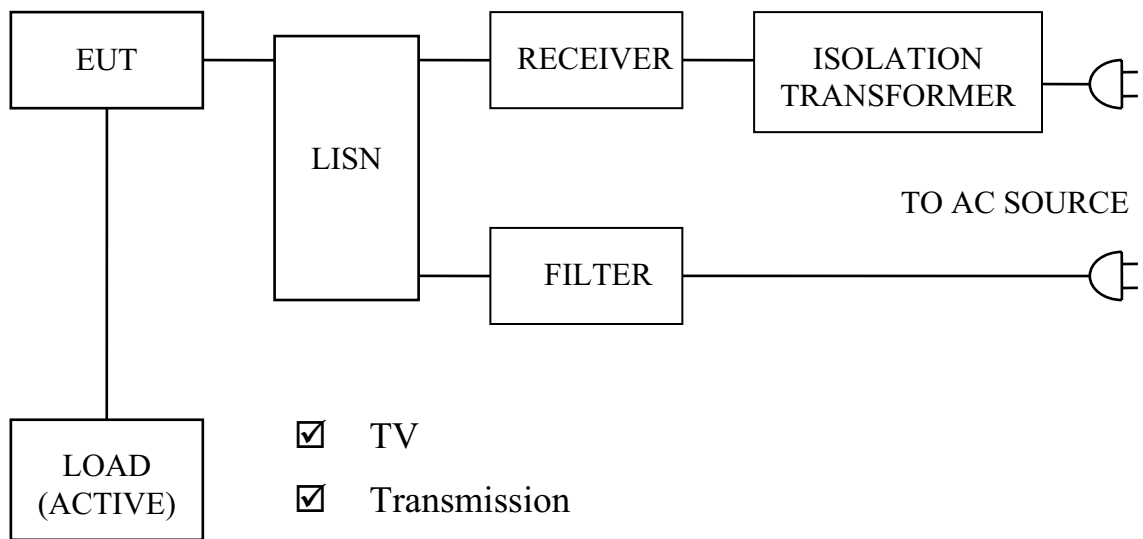

#### 4 CONFIGURATION OF THE EUT

The EUT was configured according to EN 61000-6-3. All I/O ports were connected to the appropriate peripherals. All peripherals and cables are listed below (including internal device) :

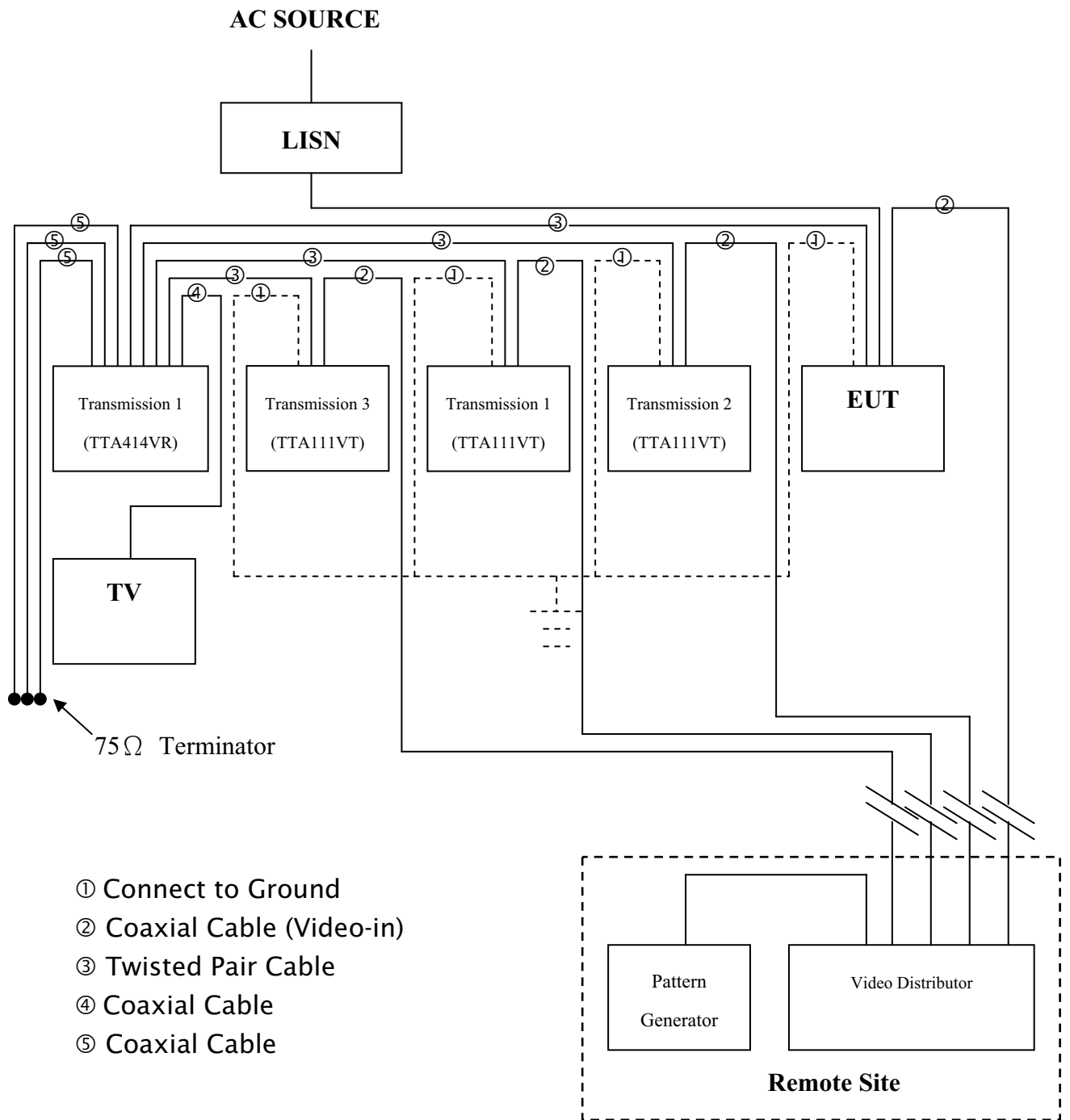

Figure 1

## 4.1 EUT

EUT Type : Proto Type Engineer Type Mass Production  
Condition when received : Good Damage : \_\_\_\_\_  
Device : Twisted Pair Transmission  
Applicant : SMART CABLING & TRANSMISSION CORP.  
Manufacturer : SMART CABLING & TRANSMISSION CORP.  
Model Number : TTA111XXX  
Serial Number : N/A  
FCC ID : N/A  
Video-In : Metal Type Connector  
Video-Out : Plastics Type Connector  
Ground : Un-Shielded, 2.0 m, Metal Type Connector  
Power Cord (AC) : 2 pin  
Power Cord (DC) : Un-Shielded, 1.8 m, 2 pin  
Power Supply Type : Linear Adapter

## 4.2 PERIPHERALS

Twisted Pair Transmission x 3

Manufacturer : SMART CABLING & TRANSMISSION CORP.  
Model Number : TTA111VT  
Serial Number : N/A  
FCC ID : N/A  
Data Cable : Shielded, 3.0 m, Connect to the Video-Out Port  
Power Cord : Un-Shielded, 1.8 m

Twisted Pair Transmission

Manufacturer : SMART CABLING & TRANSMISSION CORP.  
Model Number : TTA414VR  
Serial Number : N/A  
FCC ID : N/A  
Data Cable : Shielded, 3.0 m, Connect to the Video-Out Port  
Power Cord : Un-Shielded, 1.8 m

TV

Manufacturer : TCL  
Model Number : 1419A  
Serial Number : N/A  
FCC ID : N/A  
Data Cable : Shielded, 1.8 m, Connected to the Video-In port  
Power Cord : Un-Shielded, 1.8 m

AC Adapter

Manufacturer : ELEC  
Model Number : YAD-1200500E  
Serial Number : N/A  
FCC ID : N/A  
Data Cable : N/A  
Power Cord : Un-Shielded, 1.8 m

Video Distributor (Remote Site)

Manufacturer : CS Lilin  
Model Number : PIH-6002  
Serial Number : N/A  
FCC ID : N/A  
Data Cable : Shielded, 10 m, Connected to the Video-In port  
Power Cord : Un-Shielded, 1.8 m

Pattern Generator (Remote Site)

Manufacturer : LEADER  
Model Number : 408  
Serial Number : 3037775  
FCC ID : N/A  
Data Cable : Shielded, 1.8 m  
Power Cord : Un-Shielded, 1.8 m

4.3 REMARK : N/A

## 5 EUT OPERATING CONDITION

- 5.1 The operation frequency of the EUT is 0~10 MHz.
- 5.2 Configure the EUT according to the **EN 61000-6-3**.
- 5.3 Turn on all power of EUT and peripheral.
- 5.4 Remote pattern generator send color bar signal to video in port of Support Unit1 (Video Distributor).
- 5.5 Video output port of Support Unit1 (Video distributor) connected to video input port of EUT via 10m cable.
- 5.6 EUT's Video out port connected with the Support Unit2 (Twisted Pair Transmission TTA414VT) via 3m cable.
- 5.7 Support Unit2 (Twisted Pair Transmission TTA414VT) connected with the Support Unit3 (TV) via 1.8m cable and Support Unit3 (TV) display color signal.
- 5.8 Monitor the output signal of EUT during the test. (For EMS testing).
- 5.9 **The photos of conducted test configuration, please refer to appendix A.**

## 6 LIMIT OF CONDUCTED POWER LINE EMISSION CLASS B

Frequency Range	Quasi Peak	Average
0.15 ~ 0.5 MHz	66 - 56 dBuV	56 - 46 dBuV
0.5 ~ 5 MHz	56 dBuV	46 dBuV
5 ~ 30 MHz	60 dBuV	50 dBuV

## 7 RESULT OF CONDUCTED POWER LINE TEST

- 7.1 The frequency range from 0.15 MHz to 30 MHz was investigated. All readings are quasi-peak values and average.
- 7.2 IF bandwidth : 9 kHz, Meas Time : 1 sec.
- 7.3 Temperature : 27 °C, Humidity : 60 % RH.
- 7.4 Deviations from the test standards and rules : None.
- 7.5 The conducted test result were gained by following procedures :  
 Level = Reading Level + Insertion Loss of LISN + Cable Loss  
 (All calculation were done by ESHS30 EMI test receiver.)
- 7.6 Result : **PASSED**

## 8 CONDUCTED POWER LINE TEST DATA (PAGE 1)

HomeTek EMC LAB. TEL :886-2-22608375

16 Dec 2004 10:39

### CONDUCTED EMISSIONS

EUT: Transmission  
 Manuf: 3L026  
 Op Cond: LINE 1  
 Operator: VIC  
 Test Spec: FOR CISPR22 CLASS B  
 Comment: 230V/50Hz  
 TTA111VT  
 Result File: 3l02611c.dat : New Measurement

Prescan Measurement: Detectors: X PK / + AV  
 Meas Time: see scan settings  
 Subranges: 16  
 Acc Margin: 55 dB

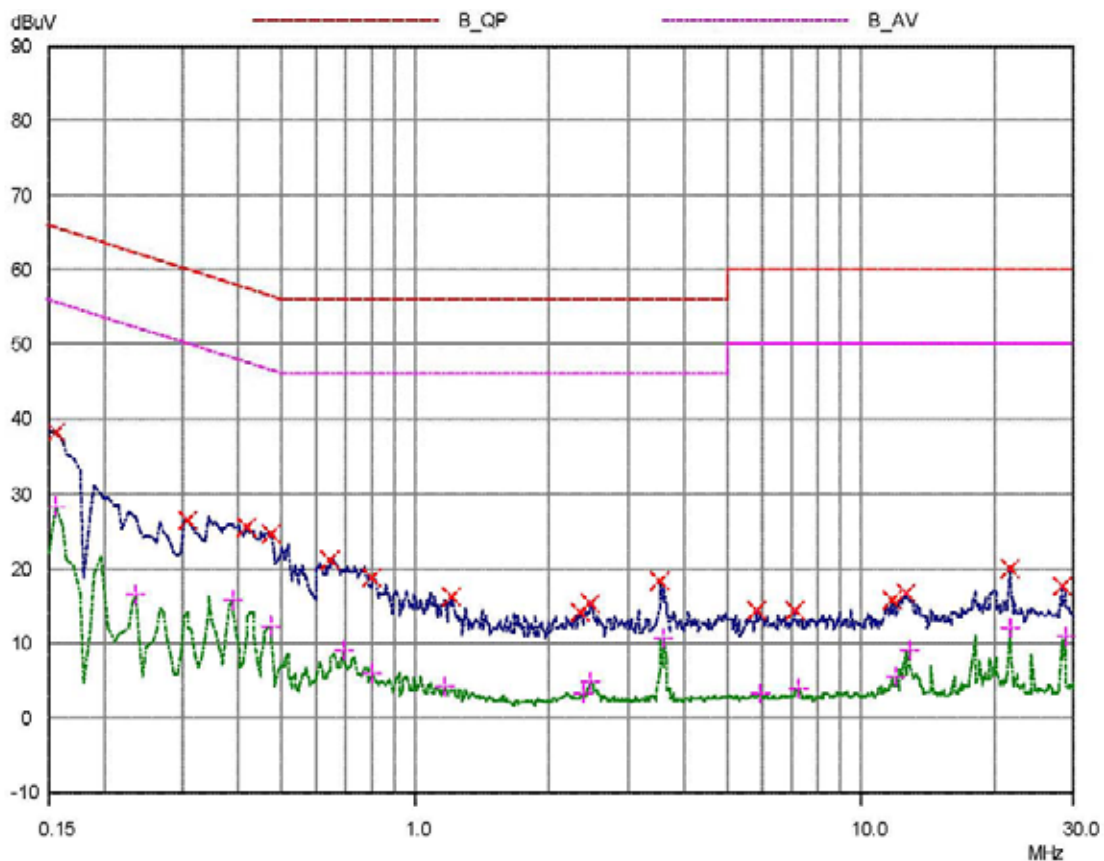



### 9 CONDUCTED POWER LINE TEST DATA (PAGE 2)

HomeTek EMC LAB. TEL :886-2-22608375

16 Dec 2004 10:39

#### CONDUCTED EMISSIONS

EUT: Transmission  
 Manuf: 3L026  
 Op Cond: LINE 1  
 Operator: VIC  
 Test Spec: FOR CISPR22 CLASS B  
 Comment: 230V/50Hz  
 TTA111VT  
 Result File: 3I02611c.dat : New Measurement

Prescan Measurement:      Detectors:      X PK / + AV  
                                  Meas Time:      see scan settings  
                                  Subranges:      16  
                                  Acc Margin:      55 dB

#### Peak Search Results

Frequency MHz	PK Level dBuV	PK Limit dBuV	PK Delta dB
0.155	38.19	65.73	27.54
0.31	26.36	59.97	33.61
0.415	25.40	57.55	32.15
0.475	24.53	56.43	31.90
0.645	21.15	56.00	34.85
0.8	18.72	56.00	37.28
1.21	16.15	56.00	39.85
2.35	14.22	56.00	41.78
2.47	15.32	56.00	40.68
3.55	18.40	56.00	37.60
5.8	14.38	60.00	45.62
7.08	14.28	60.00	45.72
11.61	15.83	60.00	44.17
12.48	16.69	60.00	43.31
21.43	19.89	60.00	40.11
28.0	17.51	60.00	42.49

Frequency MHz	AV Level dBuV	AV Limit dBuV	AV Delta dB
0.155	28.37	55.73	27.36
0.235	16.37	52.27	35.90
0.385	15.67	48.17	32.50
0.47	12.26	46.51	34.25
0.685	9.11	46.00	36.89
0.8	6.13	46.00	39.87
1.16	4.28	46.00	41.72
2.37	3.24	46.00	42.76
2.47	4.94	46.00	41.06
3.61	10.74	46.00	35.26
5.88	3.16	50.00	46.84
7.22	3.83	50.00	46.17
11.95	5.62	50.00	44.38
12.75	9.10	50.00	40.90
21.43	12.02	50.00	37.98
28.64	10.87	50.00	39.13

\* limit exceeded

### 10 CONDUCTED POWER LINE TEST DATA (PAGE 3)

HomeTek EMC LAB. TEL :886-2-22608375

16 Dec 2004 10:22

#### CONDUCTED EMISSIONS

EUT: Transmission  
 Manuf: 3L026  
 Op Cond: LINE 2  
 Operator: VIC  
 Test Spec: FOR CISPR22 CLASS B  
 Comment: 230V/50Hz  
 TTA111VT  
 Result File: 3I02621c.dat : New Measurement

Prescan Measurement: Detectors: X PK / + AV  
 Meas Time: see scan settings  
 Subranges: 16  
 Acc Margin: 55 dB

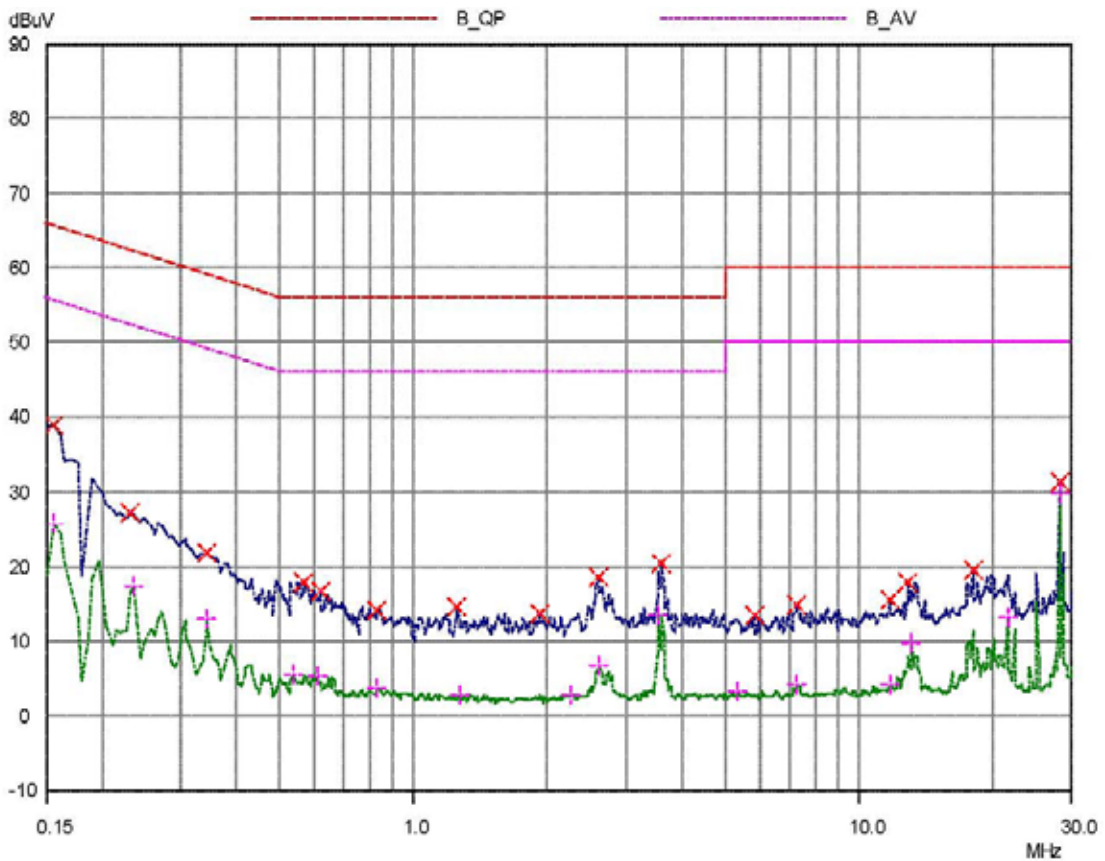



# 11 CONDUCTED POWER LINE TEST DATA (PAGE 4)

HomeTek EMC LAB. TEL :886-2-22608375

16 Dec 2004 10:22

## CONDUCTED EMISSIONS

EUT: Transmission  
 Manuf: 3L026  
 Op Cond: LINE 2  
 Operator: VIC  
 Test Spec: FOR CISPR22 CLASS B  
 Comment: 230V/50Hz  
 TTA111VT  
 Result File: 3I02621c.dat : New Measurement

Prescan Measurement:      Detectors:      X PK / + AV  
                                  Meas Time:      see scan settings  
                                  Subranges:      16  
                                  Acc Margin:     55 dB

### Peak Search Results

Frequency MHz	PK Level dBuV	PK Limit dBuV	PK Delta dB
0.155	38.81	65.73	26.92
0.23	27.17	62.45	35.28
0.345	21.80	59.08	37.28
0.57	17.92	56.00	38.08
0.615	16.68	56.00	39.32
0.83	14.11	56.00	41.89
1.25	14.59	56.00	41.41
1.91	13.78	56.00	42.22
2.58	18.53	56.00	37.47
3.61	20.39	56.00	35.61
5.79	13.38	60.00	46.62
7.26	14.90	60.00	45.10
11.61	15.48	60.00	44.52
12.82	17.87	60.00	42.13
17.93	19.40	60.00	40.60
28.0	31.37	60.00	28.63

Frequency MHz	AV Level dBuV	AV Limit dBuV	AV Delta dB
0.155	25.68	55.73	30.05
0.235	17.27	52.27	35.00
0.345	13.01	49.08	36.07
0.535	5.49	46.00	40.51
0.605	5.30	46.00	40.70
0.83	3.67	46.00	42.33
1.26	2.77	46.00	43.23
2.23	2.89	46.00	43.11
2.61	6.73	46.00	39.27
3.55	13.46	46.00	32.54
5.35	3.26	50.00	46.74
7.22	4.26	50.00	45.74
11.61	4.16	50.00	45.84
13.07	9.84	50.00	40.16
21.48	13.24	50.00	36.76
28.0	29.76	50.00	20.24

\* limit exceeded

## RADIATED EMISSION TEST

### 1 TEST INSTRUMENTS & FACILITIES

The following test Instruments was used during the radiated emission test :

Item	Instruments /facilities	Specification	Manufacturer	Model # / S/N#	Date of Cal.
1	OPEN AREA TEST SITE	<input checked="" type="checkbox"/> OATS 3			JUL/2004
2	EMI TEST RECEIVER	20Hz ~ 26.5GHz	ROHDE & SCHWARZ	ESMI 845442/006	JAN/2004
3	PRE-AMPLIFIER	9KHz ~ 3000MHz	ADVANTEST	BB525C 90081001	SEP/2004
4	ANTENNA (BI-LOG)	25MHz ~ 2GHz	SCHAFFNER	CBL6112B S/N : 2614	MAY/2004
5	Attenuation	50Ω/6dB	JYE BAO	FAT-N (M-F) 001	JUL/2004
6	Cable	10m	SUHNER	RG214/U OS3-003	DEC/2004
7	Cable	14m	BELDEN	9913 OS3-001	DEC/2004
8	EMI 32 (software)	N/A	AUDIX	19991013-0923	N/A

Note : Items 1 ~ 7 were calibrated within period of 1 year.

## 2 TEST PROCEDURE

- 2.1 The EUT was test according to **CISPR 22 Class B**.
- 2.2 The radiated test was performed at HomeTek Lab’s Open Site III.
- 2.3 The frequency range from 30 MHz to 1 GHz, the measurement were made at 10 meters, with a BI-log antenna.

## 3 TEST SETUP

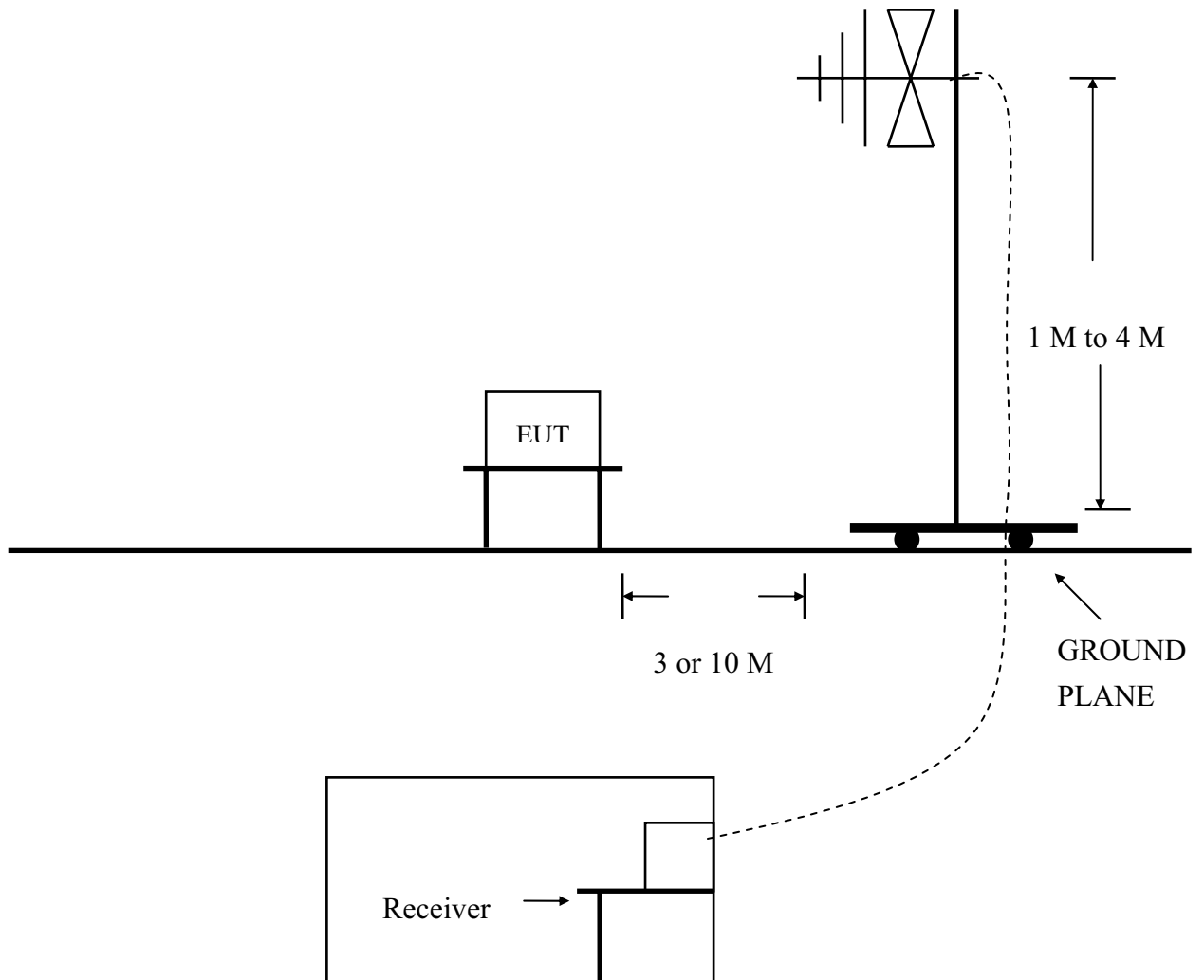

(Details for setup configuration, please refer to appendix A.)

4 CONFIGURATION OF THE EUT

Same as “Conducted Power Line test”, section 4

5 EUT OPERATING CONDITION

5.1 Same as “Conducted Power Line test”, section 5

5.2 The radiated emission in the frequency range from 30 MHz - 1000 MHz was test in a horizontal and vertical polarization at HomeTek Lab’s open site III.

**5.3 The photos of radiated test configuration, please refer to appendix A.**

6 LIMIT OF RADIATED EMISSION CLASS B

Frequency (MHz)	Measurement Distance	Limit (dBuV/m)
30 - 230	10 (M)	30
230 - 1000	10 (M)	37

7 RESULT OF RADIATED EMISSION TEST

7.1 The frequency range from 30 MHz to 1 GHz was investigated.

7.2 All readings below or equal 1 GHz are quasi-peak or peak values with resolution bandwidth of 120 KHz.

7.3 The measurements were made at 10 meters of HomeTek Lab’s open site III.

7.4 Temperature : 33 °C, Humidity : 55 % RH.

7.5 Deviation form the test standards and rules : None.

7.6 The radiated emission result were gained by the following method :

Level = Reading Level + Probe Factor (Antenna Factor) + Cable Loss – Preamp Factor

Over Limit = Level – Limit Line

7.7 Result : **PASSED**



HomeTek Technology Inc.

No 67-9, Shi-Men Rd., Tu-Chen City, Taipei County, Taiwan R.O.C. Tel:02-22608375 Fax:02-22748013

Data#: 1 File#: 31026.emi

Date: 2004-12-15 Time: 16:58:28

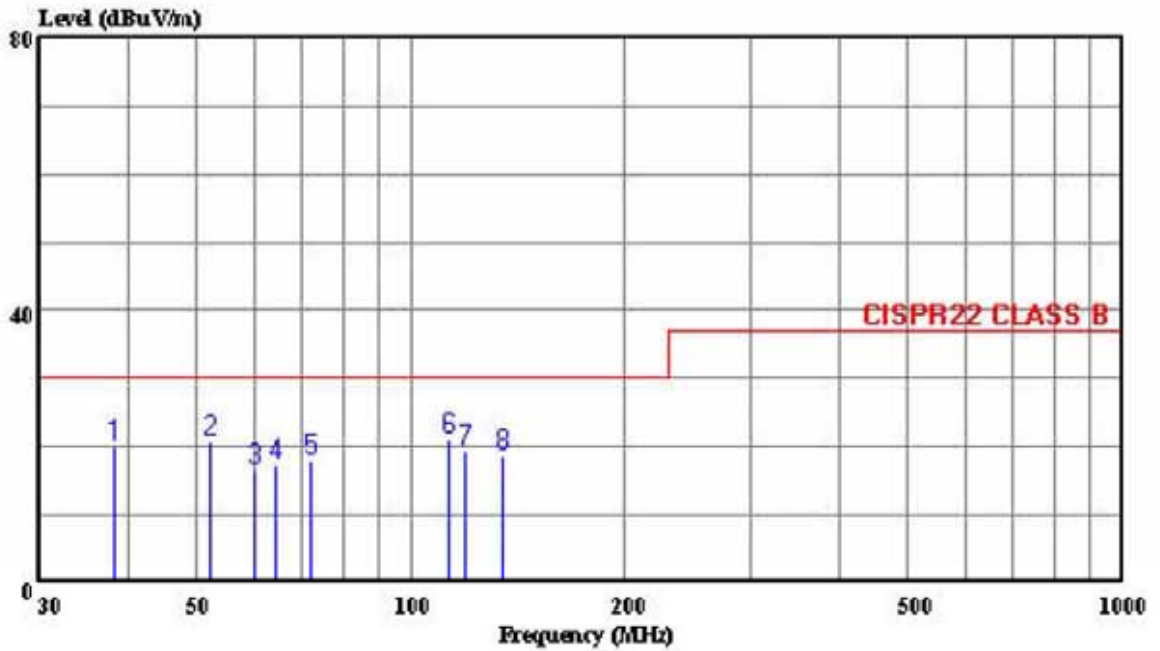

Trace:

Ref Trace:

Condition: CISPR22 CLASS B 10m CHASE 2614 052604 HORIZONTAL  
 out : Transmission  
 power: 230V/50Hz  
 memo : TTA111VT

Page: 1

	Freq	Level	Limit	Over	ReadAntenna	Cable	Preamp	Remark
	MHz	dBuV/m	dBuV/m	dB	Level	Loss	Factor	
					Factor			
					dB/m	dB	dB	
1	38.273	20.04	30.00	-9.96	35.82	13.17	0.94	29.89 Peak
2	52.260	20.69	30.00	-9.31	42.40	7.01	1.12	29.83 Peak
3	60.307	16.74	30.00	-13.26	39.58	5.68	1.17	29.70 Peak
4	64.253	17.17	30.00	-12.83	39.96	5.64	1.20	29.64 Peak
5	72.493	18.08	30.00	-11.92	40.27	6.04	1.27	29.50 Peak
6	112.507	21.14	30.00	-8.86	37.17	11.55	1.53	29.11 Peak
7	118.800	19.41	30.00	-10.59	35.32	11.68	1.56	29.15 Peak
8	134.220	18.78	30.00	-11.22	35.34	11.04	1.64	29.24 Peak



HomeTek Technology Inc.

No 67-9, Shi-Men Rd., Tu-Chen City, Taipei County, Taiwan R.O.C. Tel:02-22608375 Fax:02-22748013

Data#: 2 File#: 31026.emi

Date: 2004-12-15 Time: 17:20:49

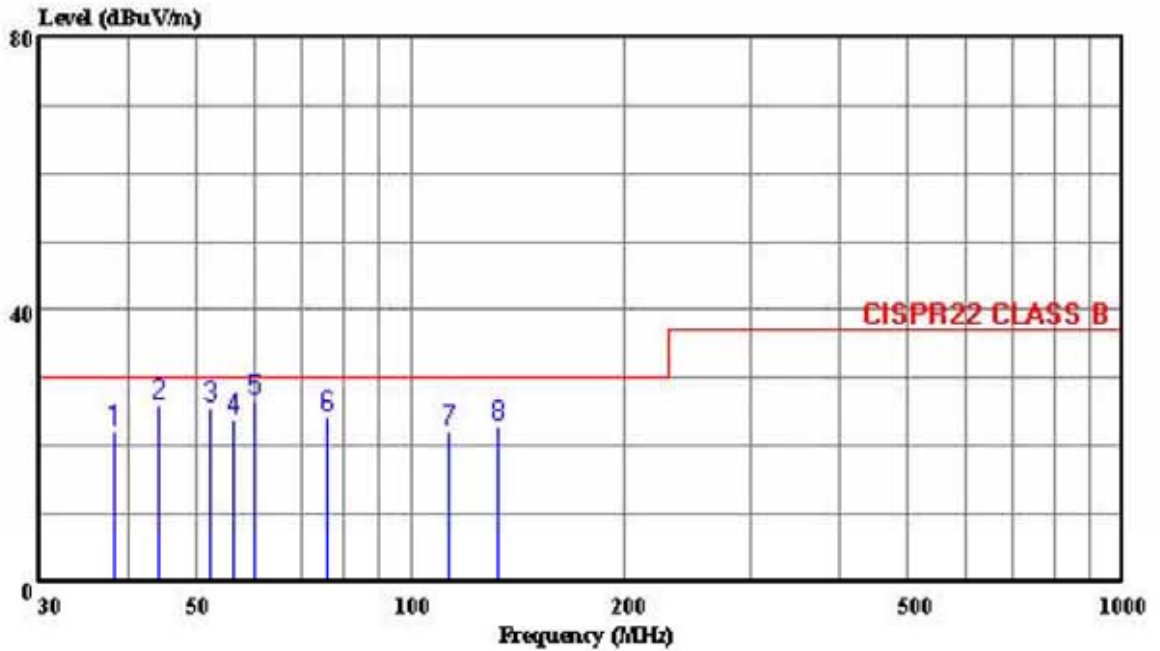

Trace:

Ref Trace:

Condition: CISPR22 CLASS B 10m CHASE 2614 052604 VERTICAL  
out : Transmission  
power: 230V/50Hz  
memo : TTAll1VT

Page: 1

	Freq	Level	Limit Line	Over Limit	ReadAntenna Level	Cable Factor	Preamp Loss	Remark
	MHz	dBuV/m	dBuV/m	dB	dBuV	dB/m	dB	dB
1	38.244	22.33	30.00	-7.67	38.11	13.17	0.94	29.89 Peak
2	44.311	26.08	30.00	-3.92	44.05	10.89	1.03	29.89 Peak
3	52.262	25.72	30.00	-4.28	47.43	7.01	1.12	29.83 Peak
4	56.289	23.77	30.00	-6.23	46.18	6.21	1.14	29.77 Peak
5	60.304	26.51	30.00	-3.49	49.35	5.68	1.17	29.70 Peak
6	76.420	24.37	30.00	-5.63	46.03	6.48	1.29	29.43 Peak
7	112.538	22.20	30.00	-7.80	38.23	11.55	1.53	29.11 Peak
8	132.631	22.95	30.00	-7.05	39.39	11.16	1.63	29.23 Peak

## HARMONICS TEST

### 1 TEST INSTRUMENTS & FACILITIES

Instruments/ facilities	Manufacturer	Model # Serial #	Date of Cal.
HARMONICS/ VOLTAGE FLUCTUATIONS TEST	EMC-PARTNER	HAR1000-1P	OCT/2004
CONTROL PC	KB TECH	KB P586/133	N/A

### 2 TEST PROCEDURE

According to **EN 61000-3-2 (2000) Class A**

### 3 TEST SETUP

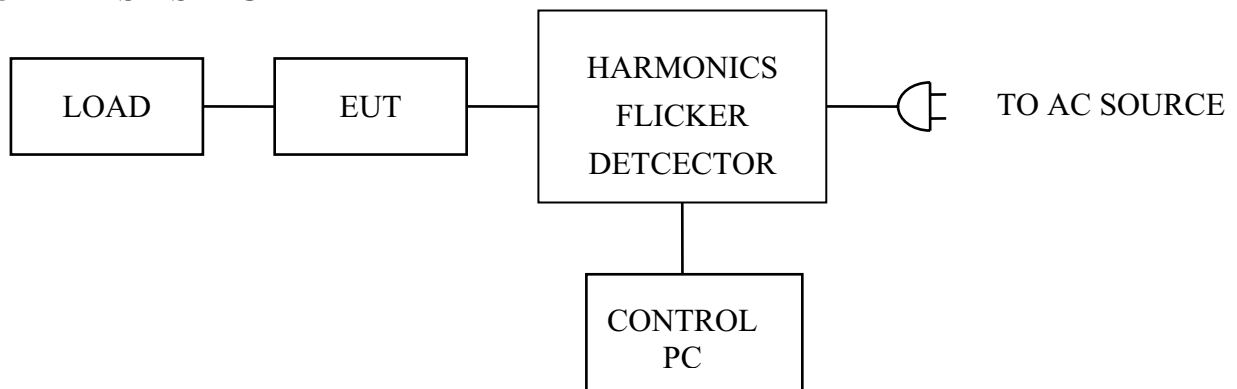

(Details for setup configuration, please refer to appendix A.)

### 4 CONFIGURATION OF THE EUT

Same as “Conducted Power Line test”, section 4

### 5 OPERATION CONDITION OF EUT

Same as “Conducted Power Line test”, section 5

### 6 TEST DATA & LIMIT

6.1 Temperature :  27  °C

6.2 Humidity :  60  % RH

### 7 Photos of test configuration please refer to appendix A.



8 HARMONICS TEST DATA (PAGE 1~2)

EMC PARTNER AG, SWITZERLAND

Date : 2004/12/16 01:38:06 V2.05

File :

Operator : VIC  
 Unit : Twisted Pair Transmission  
 Serialnumber : TTA111VT  
 Remarks 3L026

Urms = 229.9V Freq = 50.000 Range: 0.25 A  
 Irms = 0.031A Ipk = 0.069A cf = 2.241  
 P = 2.595W Pap = 7.101VA pf = 0.366  
 THDi = 45.9 % THDu = 0.10 % Class A

Test - Time : 15min ( 100 %)

Test completed, Result: PASSED

Order	Freq. [Hz]	I <sub>max</sub> [A]	I <sub>max</sub> % [%]	Limit [A]	Status
1	50	0.0392			
2	100	0.0003	0.0567	1.0800	
3	150	0.0123	2.6833	2.3000	
4	200	0.0002	0.0333	0.4300	
5	250	0.0068	1.4867	1.1400	
6	300	0.0001	0.0133	0.3000	
7	350	0.0008	0.1767	0.7700	
8	400	0.0000	0.0066	0.2300	
9	450	0.0018	0.3900	0.4000	
10	500	0.0000	0.0000	0.1840	
11	550	0.0002	0.0467	0.3300	
12	600	0.0000	0.0000	0.1533	
13	650	0.0002	0.1017	0.2100	
14	700	0.0000	0.0000	0.1314	
15	750	0.0002	0.1017	0.1500	
16	800	0.0000	0.0000	0.1150	
17	850	0.0002	0.1153	0.1324	
18	900	0.0000	0.0000	0.1022	
19	950	0.0001	0.0902	0.1184	
20	10000	0.0000	0.0000	0.0920	
21	10500	0.0001	0.0712	0.1071	
22	11000	0.0000	0.0000	0.0836	
23	11500	0.0000	0.0468	0.0978	



HomeTek Technology Inc.

24	12000.0000	0.0000	0.0767
25	12500.0001	0.0678	0.0900
26	13000.0000	0.0000	0.0708
27	13500.0000	0.0549	0.0833
28	14000.0000	0.0000	0.0657
29	14500.0000	0.0393	0.0776
30	15000.0000	0.0000	0.0613
31	15500.0000	0.0420	0.0726
32	16000.0000	0.0000	0.0575
33	16500.0000	0.0448	0.0682
34	17000.0000	0.0000	0.0541
35	17500.0000	0.0475	0.0643
36	18000.0000	0.0000	0.0511
37	18500.0000	0.0251	0.0608
38	19000.0000	0.0000	0.0484
39	19500.0000	0.0264	0.0577
40	20000.0000	0.0000	0.0460

## VOLTAGE FLUCTUATIONS TEST

### 1 TEST INSTRUMENTS & FACILITIES

Instruments/ facilities	Manufacturer	Model # Serial #	Date of Cal.
HARMONICS/ VOLTAGE FLUCTUATIONS TEST	EMC-PARTNER	HAR1000-1P	OCT/2004
CONTROL PC	KB TECH	KB P586/133	N/A

### 2 TEST PROCEDURE

According to EN 61000-3-3 (1995) + A1 (2001)

### 3 TEST SETUP

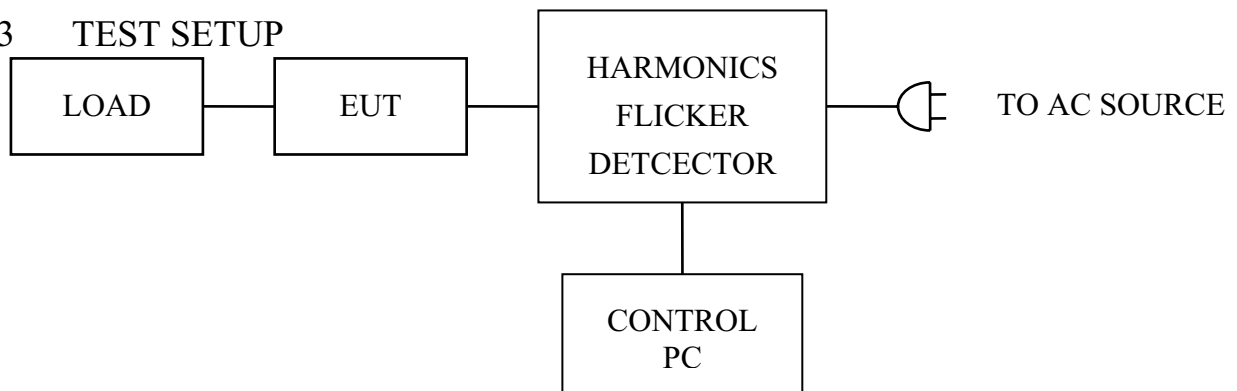

(Details for setup configuration, please refer to appendix A.)

### 4 CONFIGURATION OF THE EUT

Same as “Conducted Power Line test”, section 4

### 5 OPERATION CONDITION OF EUT

Same as “Conducted Power Line test”, section 5

### 6 TEST DATA & LIMIT

6.1 Temperature :   27   °C

6.2 Humidity :   60   % RH

### 7 Photos of test configuration please refer to appendix A.



8 VOLTAGE FLUCTUATIONS TEST DATA (PAGE 1)

EMC PARTNER AG, SWITZERLAND

Date : 2004/12/16 01:55:40 V2.05

File :

Operator : VIC  
 Unit : Twisted Pair Transmission  
 Serialnumber : TTA111VT  
 Remarks 3L026

Urms = 229.9V Freq = 49.984 Range: 0.25 A  
 Irms = 0.031A Ipk = 0.069A cf = 2.249  
 P = 2.601W Pap = 7.101VA pf = 0.366

Test - Time : 1 x 15min = 15min ( 100 %)

LIN (Line Impedance Network) : Soft LIN 0.24 Ohm +j 0.15 Ohm N: 0.16 Ohm +j 0.10 Ohm

Limits :Plt : 0.65Pst : 1.00  
 dmax : 4.00 % dc : 3.00 %  
 dtLim: 3.00 % dt>Lim: 200ms

Test completed, Result: PASSED

Plt = 0.072

	Pst	dmax
		[%]
1	0.072	0.000

## ELECTROSTATIC DISCHARGE IMMUNITY TEST (ESD)

### 1 TEST INSTRUMENTS & FACILITIES

Instruments/ Facilities	Manufacturer	Model # Serial #	Data Of Cal.
ESD TESTER	NOISEKEN	ESS-100L (A)	OCT/2004
VCP	HOMETEK	--	--

### 2 TEST PROCEDURE

According to IEC 61000-4-2 (2001)

According to EN 50130-4 (1995) + A1 (1998) +A2 (2003)

### 3 TEST SETUP

TABLE SIZE

160L X 80W X 80H cm

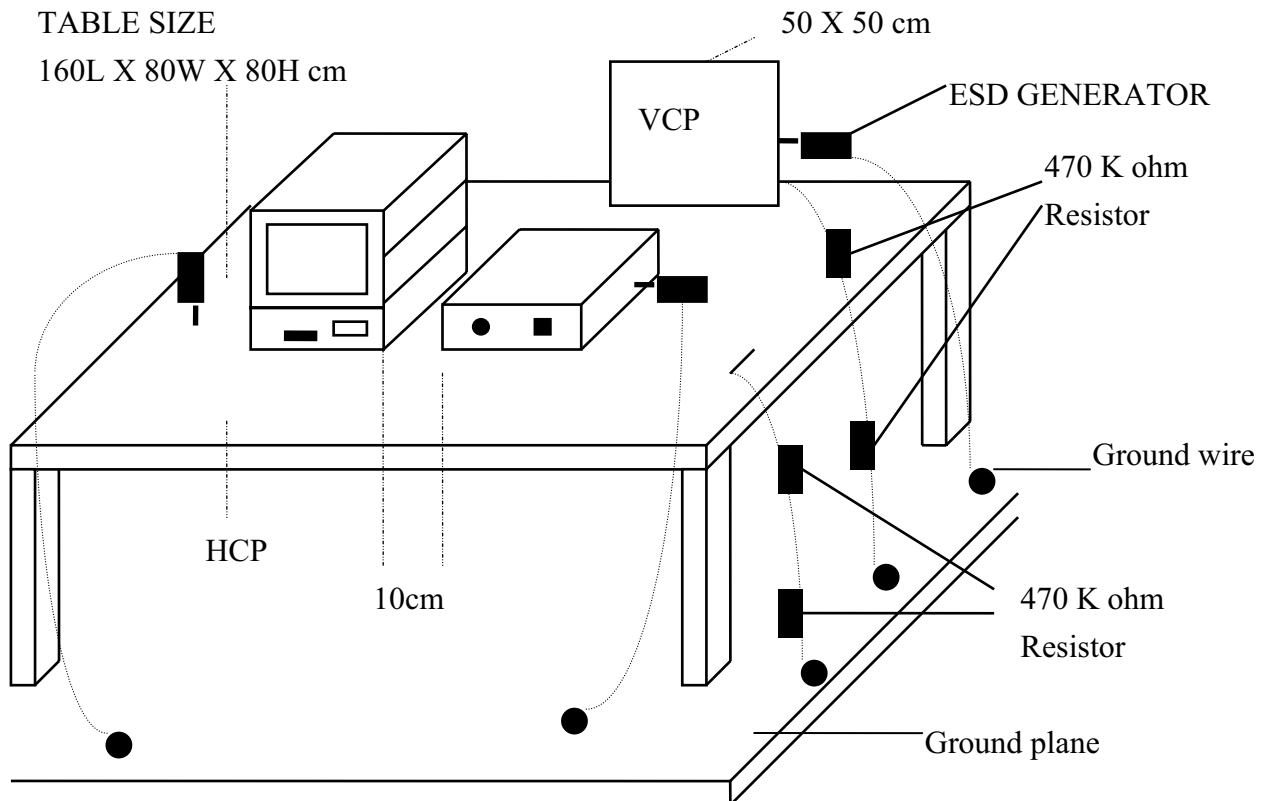

(Details for setup configuration, please refer to appendix A.)

#### 4 CONFIGURATION OF THE EUT

Same as “Conducted Power Line test”, section 4

#### 5 EUT OPERATION CONDITION

Same as “Conducted Power Line test”, section 5

#### 6 TEST CONDITION

##### 6.1 Test Level :

(A)  $\pm 2, 4, 8$  KV for air discharge.

(B)  $\pm 2, 4, 6$  KV for contact discharge.

6.2 Number of test : 10 Discharges / Test point / Polarity / Level

6.3 Time between test :  $\geq 1$  sec.

6.4 Temperature : 26 °C

6.5 Humidity : 54 % RH.

#### 7 PERFORMANCE CRITERIA

There shall be no damage, malfunction or change of status due to the conditioning. Flickering of an indicator during the application of the discharges is permissible, providing that there is no residual change in the EUT or any change in outputs, which could be interpreted by associated equipment as a change.

The EUT shall meet the acceptance criteria for the functional test, after the conditioning.

## 8 TEST RESULT

Test Point	Air Discharge	Contact Discharge	Result
HCP	---	$\pm 2, 4, 6KV$	<b>PASSED</b>
VCP	---	$\pm 2, 4, 6KV$	<b>PASSED</b>
CASE	$\pm 2, 4, 8KV$	$\pm 2, 4, 6KV$	<b>PASSED</b>
I/O PORTS	$\pm 2, 4, 8KV$	$\pm 2, 4, 6KV$	<b>PASSED</b>
LED	$\pm 2, 4, 8KV$	$\pm 2, 4, 6KV$	<b>PASSED</b>
SCREWS	$\pm 2, 4, 8KV$	$\pm 2, 4, 6KV$	<b>PASSED</b>
DC SOCKET	$\pm 2, 4, 8KV$	$\pm 2, 4, 6KV$	<b>PASSED</b>

※ The screen was flash during the test.

## 9 Photos of test configuration please refer to appendix A.

## RADIO FREQUENCY ELECTROMAGNETIC FIELD IMMUNITY TEST (RS)

### 1 TEST INSTRUMENTS & FACILITIES

Item	Instruments Facilities	Manufacturer	Model # Serial #	Data Of Cal.
1	SIGNAL GENERATOR	HP	8648B	FEB/2007
2	POWER SENSOR	BOONTON	51011-EMC	SEP/2006
3	POWER METER	BOONTON	4231A-01	SEP/2006
4	FIELD PROBE	HOLADAY	HI-6005	NOV/2006
5	AMPLIFIER	SCHAFFNER	CBA9428	N/A
6	ANTENNA	SCHAFFNER	CBL6141A	N/A

Note : Items 1 ~ 4 were calibrated with two years and verified before testing.

### 2 TEST PROCEDURE

According to **IEC 61000-4-3 (2002)**

According to **EN 50130-4 (1995) + A1 (1998) + A3 (2003)**

### 3 TEST SETUP

#### FERRITE TILE

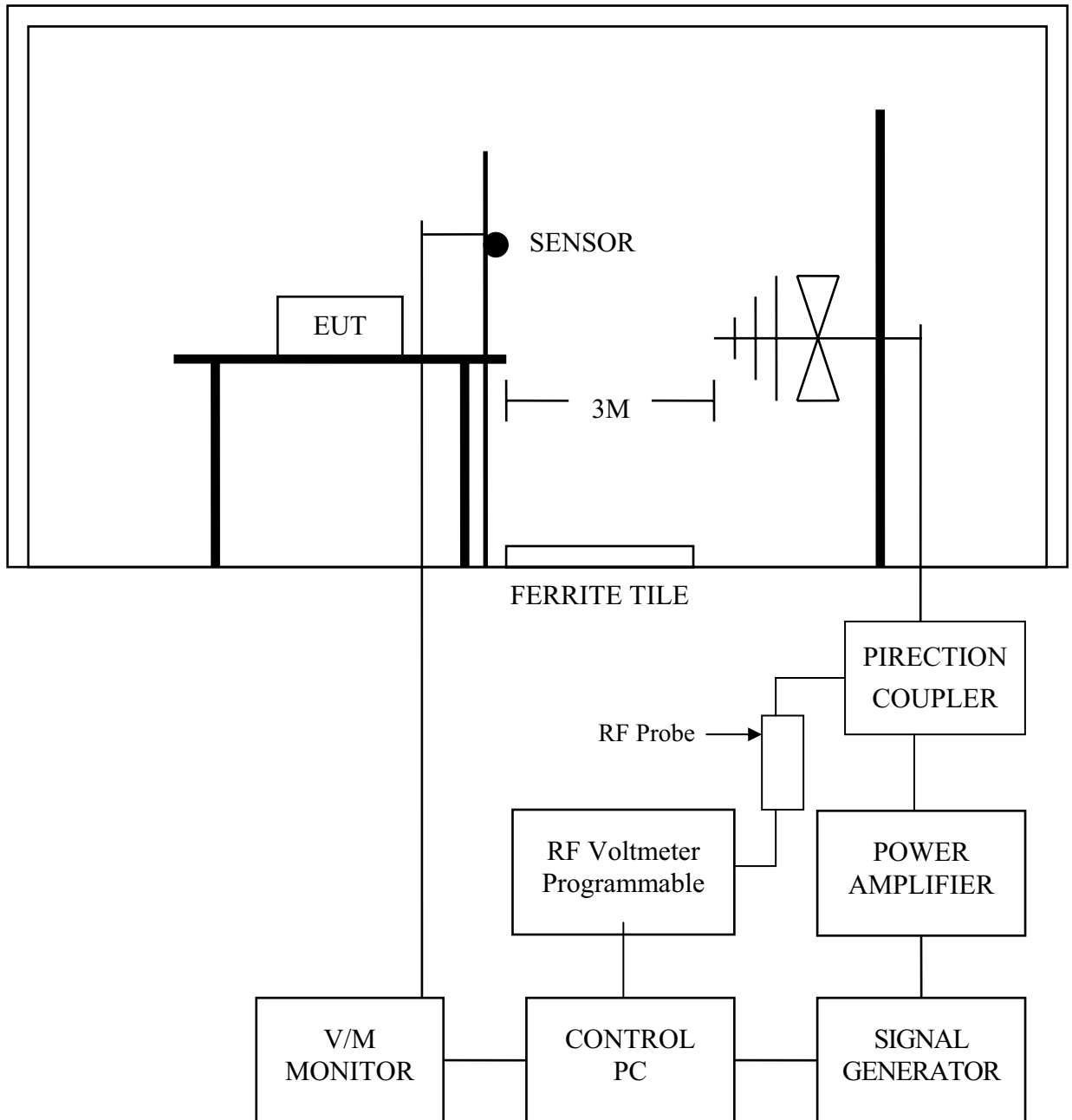

#### 3.1 Chamber Size :

12M x 5M x 5M

(Details for setup configuration, please refer to appendix A.)

#### 4 CONFIGURATION OF THE EUT

Same as “Conducted Power Line test”, section 4

#### 5 OPERATION CONDITION OF EUT

Same as “Conducted Power Line test”, section 5

#### 6 TEST CONDITION

6.1 Frequency Range : 80 MHz ~ 2000 MHz

6.2 Field Strength : 10 V / M (1KHz 80% Sinusoidal amplitude modulation)  
10 V / M (1KHz 0.5s on : 0.5s off pulse modulation)

6.3 Frequency Step : 1 %, 3 sec. / each step size

6.4 Antenna Polarity : HORIZONTAL & VERTICAL

6.5 The four sides of EUT are tested  
(FRONT, REAR, RIGHT, LEFT)

6.6 Temperature : 31 °C

6.7 Humidity : 58 % RH

#### 7 PERFORMANCE CRITERIA

There shall be no damage, malfunction or change of status due to the conditioning. Flickering of an indicator during the conditioning is permissible, providing that there is no residual change in the EUT or any change in outputs, which could be interpreted by associated equipment as a change, and no such flickering of indicators occurs at a field strength of 3 V/m.

For components of CCTV system, where the status is monitored by observing the TV picture, then deterioration of the picture is allowed at 10 V/m, providing :

- a There is no permanent damage or change to the EUT (e.g. no corruption of memory or changes to programmable setting etc.);
- b At 3 V/m, any deterioration of the picture is so minor that the system could still be used;
- c There is no observable deterioration of the picture at 1 V/m.

The EUT shall meet the acceptance criteria for the functional test, after the conditioning.

8 TEST RESULT

ANT SIDE	HORIZONTAL	VERTICAL
FRONT	PASSED	PASSED
REAR	PASSED	PASSED
RIGHT	PASSED	PASSED
LEFT	PASSED	PASSED

9 **Photos of test configuration please refer to appendix A.**

## ELECTRICAL FAST TRANSIENT/BURST IMMUNITY TEST (EFT)

### 1 TEST INSTRUMENTS & FACILITIES

Instruments/ Facilities	Manufacturer	Model # Serial #	Data Of Cal.
BURST-TESTER	HAEFELY	PEFT/JUNIOR	FEB/2004
CONTROL PC	KB TECH	KB P586/133	--

### 2 TEST PROCEDURE

According to **IEC 61000-4-4 (2004)**

According to **EN 50130-4 (1995) + A1 (1998) + A2 (2003)**

### 3 TEST SETUP

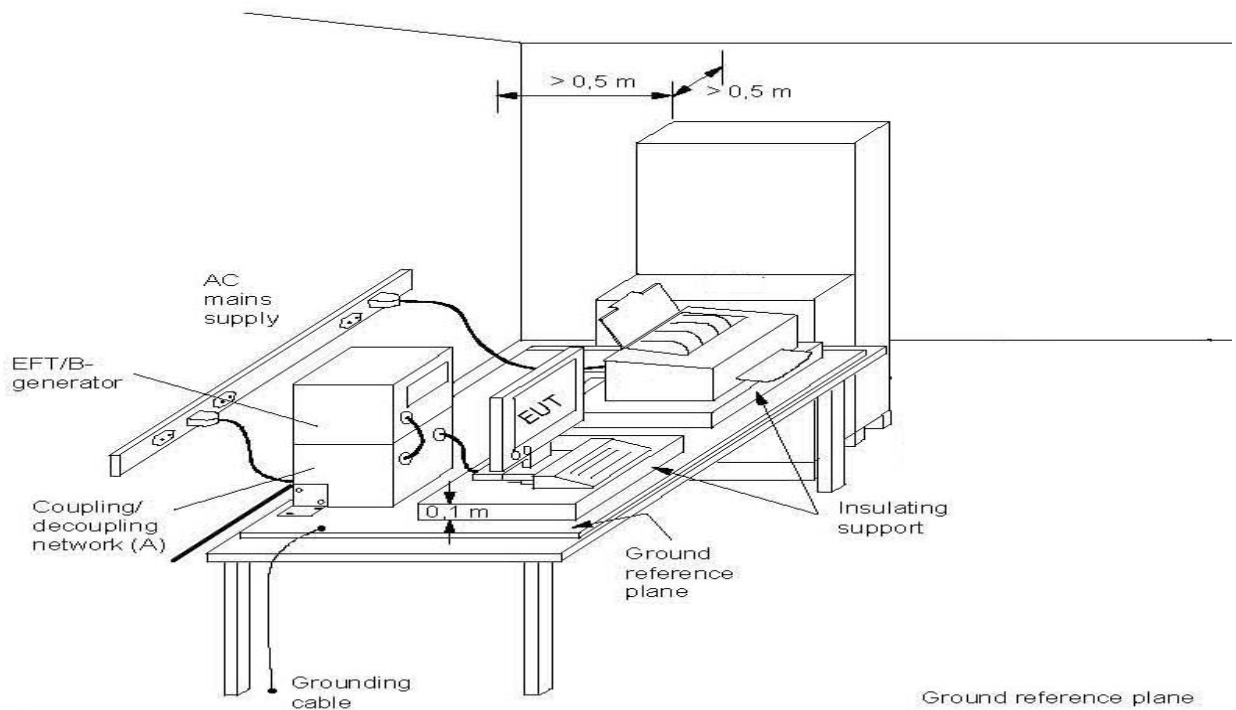

(Details for setup configuration, please refer to appendix A.)

Note: length between clamp and the EUT to be tested (should be  $0.5 \text{ m} \pm 0.05 \text{ m}$ )

(A) location for supply line coupling

(B) location for signal line coupling

#### 4 CONFIGURATION OF THE EUT

Same as “Conducted Power Line test”, section 4

#### 5 OPERATION CONDITION OF EUT

Same as “Conducted Power Line test”, section 5

#### 6 TEST CONDITION

6.1 Pulse Rise time & Duration : 5 nS / 50 nS

6.2 Pulse Repetition : 5 kHz

6.3 Polarity : POSITIVE / NEGATIVE

6.4 Test Voltage of Power Line :  $\pm 0.5\text{KV}$ ,  $\pm 1\text{KV}$ ,  $\pm 2\text{KV}$

6.5 Coupling of power line :  
L, N, L+N

6.6 Test Voltage of Signal Control Line :  $\pm 0.25\text{KV}$ ,  $\pm 0.5\text{KV}$ ,  $\pm 1\text{KV}$

6.7 Temperature : 27 °C

6.8 Humidity : 60 % RH

#### 7 PERFORMANCE CRITERIA

There shall be no damage, malfunction or change of status due to the conditioning. Flickering of an indicator during the application of the bursts is permissible, providing that there is no residual change in the EUT or any change in outputs, which could be interpreted by associated equipment as a change.

The EUT shall meet the acceptance criteria for the functional test, after the conditioning.

## 8 TEST RESULT

Power Line :

TEST VOLTAGE	L	N	L+N
±0.5KV	✓	✓	✓
±1KV	✓	✓	✓
±2KV	✓	✓	✓

※ There were snowflakes on the TV during the test.

Signal Control Line :

TEST VOLTAGE	PERFORMACE CRITERIA
±0.25KV	✓
±0.5KV	✓
±1KV	✓

8.1 Model : TTA111VT

8.2 Final Result : PASSED

8.3 Remark :

## 9 Photos of test configuration please refer to appendix A.

## SURGE IMMUNITY TEST

### 1 TEST INSTRUMENTS & FACILITIES

Instruments/ Facilities	Manufacturer	Model # Serial #	Data Of Cal.
SURGER-TESTER	HAEFELY	PSURGE 4010 583334-38	FEB/2004
ECAT CONTROL CENTER	KeyTek	E-Class Series 100 9502325	OCT/2004
I/O Signal Line Coupler / Decoupler	KeyTek	CM-I / OCD 0103234	--
CONTROL PC	KB TECH	KB P586/133	--

### 2 TEST PROCEDURE

According To **IEC 61000-4-5 (2001)**

According To **EN 50130-4 (1995) + A1 (1998) + A2 (2003)**

### 3 TEST SETUP

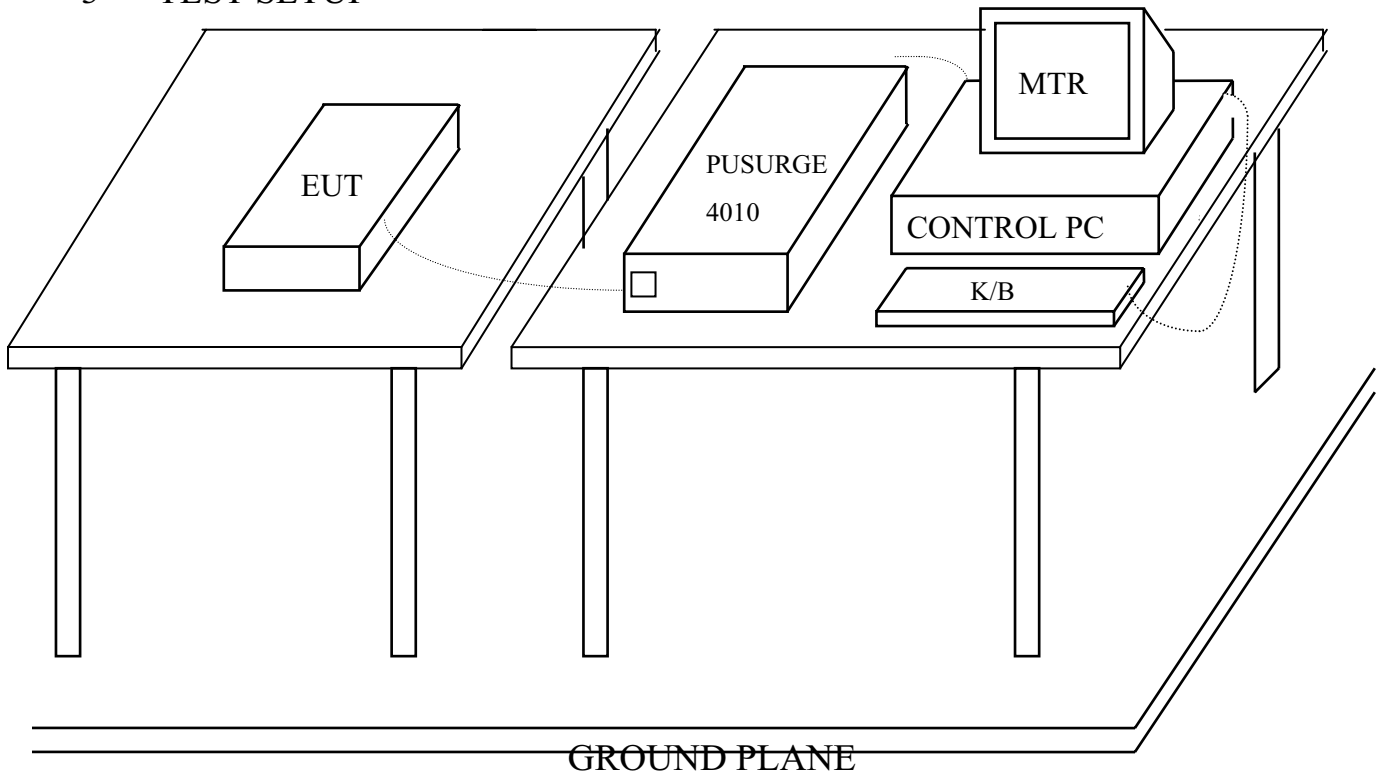

(Details for setup configuration, please refer to appendix A.)

#### 4 TEST LEVELS

- Input and Output AC Power Ports.
- DC Input and DC Output Power Ports.

Environmental Phenomena	Test Specification		Units
	AC	DC	
Test voltage <sup>1)</sup> :			
a.c. mains supply lines:			
Line to Line	±0.5, 1	N/A	KV (Charge Voltage)
Line to ground <sup>2)</sup>	±0.5, 1, 2	N/A	KV (Charge Voltage)
other supply / signal lines: <sup>3)</sup>			
Line to ground <sup>4)</sup>	N/A	±0.5, 1	KV (Charge Voltage)
Polarity	+ and -		
Minimum number of surges at each polarity, voltage, coupling mode and line:			
a.c. mains supply lines	20 <sup>5)</sup>		
Other supply / signal lines	5		
<p>1) The test voltages specified are the open-circuit voltages. The test voltages for the lower severity levels are included, because all the lower severity levels must also be satisfied.</p> <p>2) Via a 10Ω series resistor.</p> <p>3) No test is required where the manufacturer’s specification indicates that it is not permitted to connect cables &gt;30m long.</p> <p>4) Via a 40Ω series resistor.</p> <p>5) Five at each zero-crossing point and at the maximum and minimum points on the mains voltage wave.</p>			

#### 5 CONFIGURATION OF THE EUT

Same as “Conducted Power Line test”, section 4

#### 6 EUT OPERATION CONDITION

Same as “Conducted Power Line test”, section 5

## 7 CONDITIONS DURING TESTING

### 7.1 Coupling of power line :

(A) Line to Line  $\pm 0.5\text{KV}$ ,  $\pm 1\text{KV}$  (AC)

(B) Line to Ground  $\pm 0.5\text{KV}$ ,  $\pm 1\text{KV}$  (DC)

### 7.2 Test Voltage of Signal Control Line : $\pm 0.5\text{KV}$ , $\pm 1\text{KV}$

### 7.2 Polarity : POSITIVE / NEGATIVE

### 7.3 Phase shifting in a range between $0^\circ$ to $360^\circ$

### 7.4 Repetition rate at least 1 per min

### 7.5 Test times on ac mains supply lines :

5 at each zero-crossing point and at the maximum and minimum point on the mains voltage wave.

### 7.6 Test times on signal lines : 5

### 7.7 Temperature : 27 °C ( $15^\circ\text{C} \sim 35^\circ\text{C}$ )

Humidity : 60 % RH.( $10\% \sim 75\%$ )

## 8 PERFORMANCE CRITERIA

There shall be no damage, malfunction or change of status due to the conditioning. Flickering of an indicator during the application of the surges is permissible, providing that there is no residual change in the EUT or any change in outputs, which could be interpreted by associated equipment as a change.

The EUT shall meet the acceptance criteria for the functional test, after the conditioning.

## 9 TEST RESULT

Power Line :

Environmental Phenomena	Test Specification	Units
Line to Line	$\pm 0.5, 1$	KV (Charge Voltage)

Signal Control Line :

Environmental Phenomena	TEST VOLTAGE	Units
Video Output	$\pm 0.5, 1$	KV (Charge Voltage)

9.1 Model : TTA111VT

9.2 Final Result : PASSED

9.3 Remark :

**10 Photos of test configuration please refer to appendix A.**

## IMMUNITY TEST TO CS CONDUCTED DISTURBANCE

### 1 TEST INSTRUMENTS & FACILITIES

Instruments/ Facilities	Manufacturer	Model # Serial #	Date Of Cal.
SIGNAL GENERATOR	ROHDE & SCHWARZ	SMY02 845181/025	MAR/2004
SIGNAL GENERATOR	Agilent	8648C 4108A05773	SEP/2004
AMPLIFIER	AMPLIFIER RESEARCH	75A250 25680	N/A
AMPLIFIER (75Watts 10KHz-250MHz)	AMPLIFIER RESEARCH	75A250AM1 306334	N/A
RF VOLTMETER	BOONTON	9200C 361701AA	MAR/2004
RF PROBE	BOONTON	952001B 37082	MAR/2004
DIRECTION COUPLER	AMPLIFIER RESEARCH	DC2600 20508	N/A
COUPLING DECOUPLING NETWORK	FCC	FCC-801-M3-25A 9993	FEB/2004
POWER METER	Boonton	4232A-01-02 98601	SEP/2004
POWER SENSOR	Boonton	51011-EMC 32862	SEP/2004
POWER SENSOR	Boonton	51011-EMC 32864	FEB/2004
EM Injection Clamp	Fischer Custom Communications, Inc.	F-203I-23mm 421	FEB/2004
CONTROL PC	KB TECH	KB P586/133	--

### 2 TEST PROCEDURE

According To **ENV 50141 (1993)**

According To **EN 50130-4 (1995) + A1 (1998) + A2 (2003)**

### 3 TEST SETUP

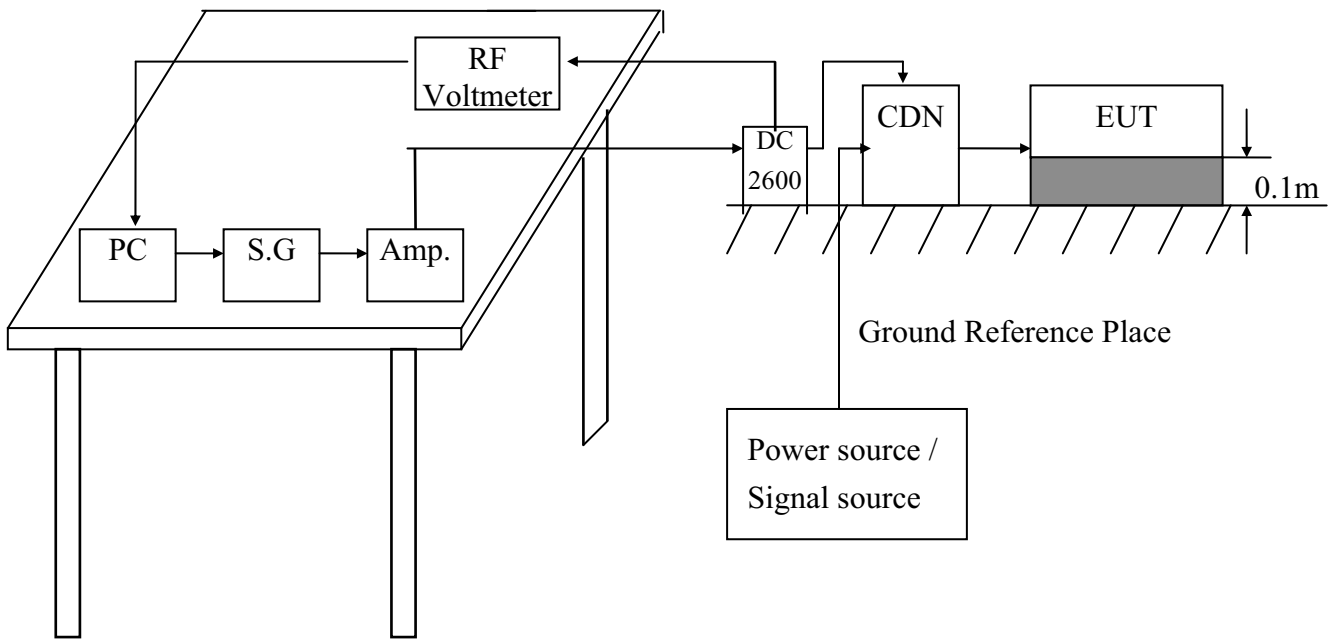

(Details for setup configuration, please refer to appendix A.)

#### 4 TEST LEVELS

- Ports for signal lines and control lines.
- DC input and DC output power ports.
- Input and Output AC Power Ports.
- Functional earth Ports.

Environmental	Test Specification	Units
Radio-frequency	0.15 - 100	MHz
Common mode	10	V
Amplitude Modulation	80	% (1KHz)
Pulse Modulation	1	Hz (0.5s on : 0.5s off)

#### 5 CONFIGURATION OF THE EUT

Same as “Conducted Power Line test”, section 4

#### 6 EUT OPERATION CONDITION

Same as “Conducted Power Line test”, section 5

#### 7 CONDITIONS DURING TESTING

7.1 The EUT tested type :

- Single unit
- Multiple unit

7.2 Dwell time : < 3 Seconds

7.3 Step size : < 1%

7.4 Test times : 3 times (pulse modulation)

7.5 Temperature : 27 °C (15°C ~ 35°C)

Humidity : 60 % RH.(10 % ~ 75%)

## 8 PERFORMANCE CRITERIA

There shall be no damage, malfunction or change of status due to the conditioning. Flickering of an indicator during the conditioning is permissible, providing that there is no residual change in the EUT or any change in outputs, which could be interpreted by associated equipment as a change, and no such flickering of the picture is allowed at 10V, providing :

- a There is no permanent damage or change to the EUT (e.g. no corruption of memory or changes to programmable settings etc.);
- b At  $U_0 = 3V$ , any deterioration of the picture is so minor that the system could still be used;
- c There is no observable deterioration of the picture at  $U_0 = 1V$ .

The EUT shall meet the acceptance criteria for the functional test, after the conditioning.

## 9 TEST RESULT

TEST Specification	Unit
0.15 - 100	MHz
10	V
80	% (1KHz)
1	Hz (0.5s on : 0.5s off)

※ At radio frequency test between 91MHz to 98MHz, there was shake on the TV during the test. (Ports for signal lines and control lines)

9.1 Model : TTA111VT

9.2 Final Result : PASSED

9.3 Remark :

**10 Photos of test configuration please refer to appendix A.**

## VOLTAGE DIPS, SHORT INTERRUPTIONS IMMUNITY TEST AND MAIN SUPPLY VARIATIONS

### 1 TEST INSTRUMENTS & FACILITIES

Instruments/ Facilities	Manufacturer	Model # Serial #	Data Of Cal.
LINE INTERFERENCE -TESTER	HAEFELY	PLINE 1610 080166-10	FEB/2007
CONTROL PC	KB TECH	KB P586/133	--
FREQUENCY CONVERTER	EXTECH	CFC-130	--
DIGITAL MULTIMETER	ESCORT	EDM-88 30802175	AUG/2006

### 2 TEST PROCEDURE

According To **IEC 61000-4-11 (2004)**

According To **EN 50130-4 (1995) + A1 (1998) + A2 (2003)**

### 3 TEST SETUP

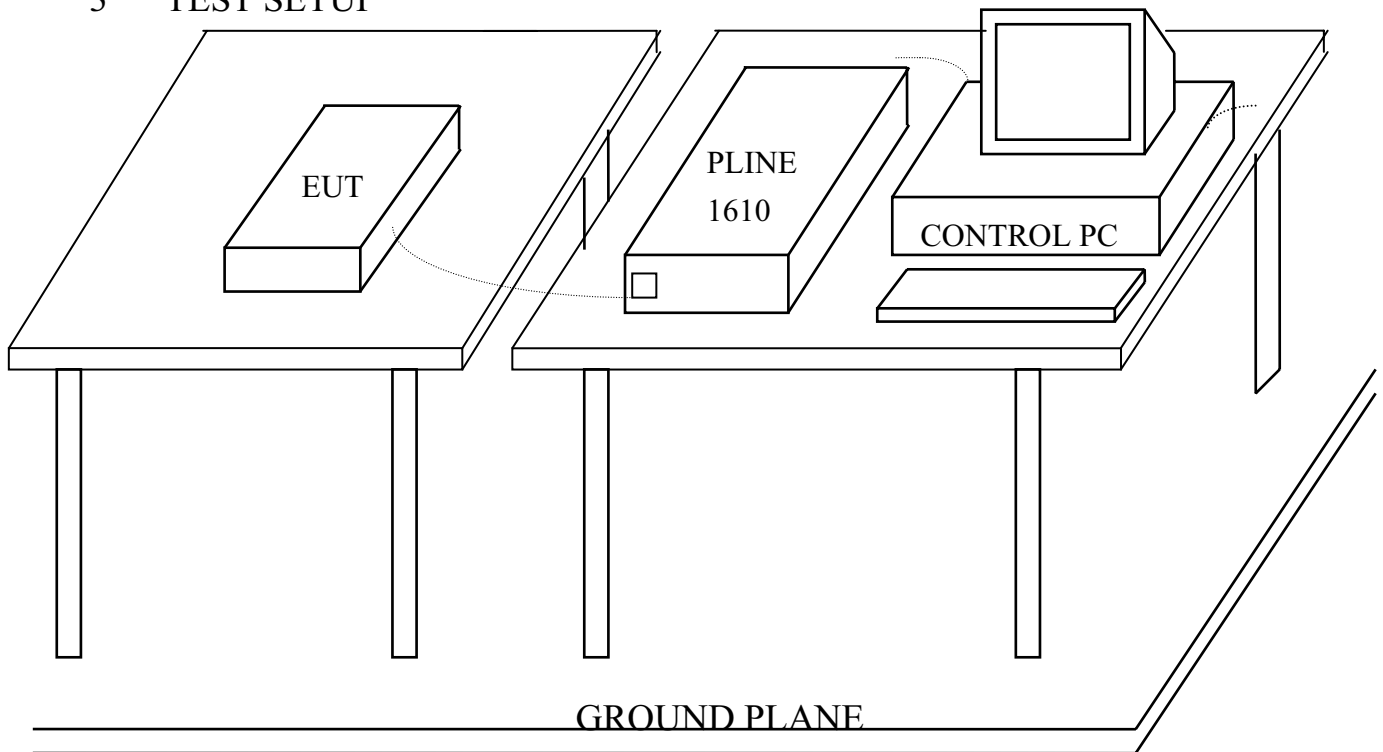

(Details for setup configuration, please refer to appendix A.)

#### 4 TEST LEVELS FOR DIPS

Input and Output AC Power Ports.

- Voltage Dips.
- Voltage Interruptions.

Environmental Phenomena	Test Specification	Units
Voltage Dips	30 0.5, 1, 5, 10	% Reduction periods
	60 0.5, 1, 5, 10	% Reduction periods
	100 0.5, 1, 5	% Reduction periods
Interval between reductions	$\geq 10$	Second
Number of reduction at each duration	3 (Voltage Dip 60) 3 (Voltage Dip 100)	Times

#### 5 CONFIGURATION OF THE EUT

Same as “Conducted Power Line test”, section 4

#### 6 EUT OPERATION CONDITION

Same as “Conducted Power Line test”, section 5

#### 7 CONDITIONS DURING TESTING

7.1 Temperature : 27 °C (15°C ~ 35°C)

Humidity : 60 % RH.(25 % ~ 75%)

## 8 PERFORMANCE CRITERIA

There shall be no damage, malfunction or change of status due to the conditioning. Flickering of an indicator during the conditioning is permissible, providing that there is no residual change in the EUT or any change in outputs, which could be interpreted by associated equipment as a change.

The EUT shall meet the acceptance criteria for the functional test, after the conditioning.

## 9 TEST RESULT

Same as “Voltage Dips, Short Interruptions Immunity Test and Main Supply Variations”, section 4

9.1 Model : TTA111VT

9.2 Final Results : PASSED

9.3 Remark

## 10 TEST LEVELS FOR MAIN SUPPLY VARIATIONS

Extreme Voltages		Voltage Applied	Perform Criteria
Supply voltage max (Umax)	Unom + 10%	253.0V	A
Supply voltage min (Umin)	Unom – 15%	195.5V	A

## 11 PERFORMANCE CRITERIA

- A. The apparatus or system shall continue to operate as intended while performs testing. No degradation of performance or loss of function is allowed below. No degradation or influence for display picture.
- B. The apparatus or system might have influence from electrical interference while testing, however there is normal operation after turn off electrical interference. It is allowance that is following phenomenon that is appeared while turn on the elector interference.
- C. The apparatus or system lost or temporary lost the function while performs the testing, it shall operate normally after turn off the elector interference or reset the apparatus main power.

## 12 TEST RESULT

Same as “Voltage Dips, Short Interruptions Immunity Test and Main Supply Variations”, section 10

12.1 Model : TTA111VT

12.2 Final Results : PASSED

12.3 Remark

## 13 Photos of test configuration please refer to appendix A.



HomeTek Technology Inc.

## **Appendix A**

# **PHOTOS OF TEST CONFIGURATION**

## PHOTO OF CONDUCTED POWER LINE TEST

Model : TTA111VT



Front View



Rear View

### PHOTO OF RADIATED EMISSION TEST

Model : TTA111VT



Front View



Rear View

**PHOTO OF HARMONICS & VOLTAGE FLUCTUATIONS TEST  
AND SURGE IMMUNITY TEST AND VOLTAGE DIPS, SHORT  
INTERRUPTIONS IMMUNITY TEST**

Model : TTA111VT



**PHOTO OF ELECTRICAL FAST TRANSIENT/BURST IMMUNITY  
TEST**



**PHOTO OF ELECTROSTATIC DISCHARGE IMMUNITY TEST  
(ESD)**

Model : TTA111VT



Front View

**PHOTO OF RADIO FREQUENCY ELECTROMAGNETIC FIELD  
IMMUNITY TEST (RS)**

Model : TTA111VT



**PHOTO OF CS CONDUCTED DISTURBANCE IMMUNITY TEST**

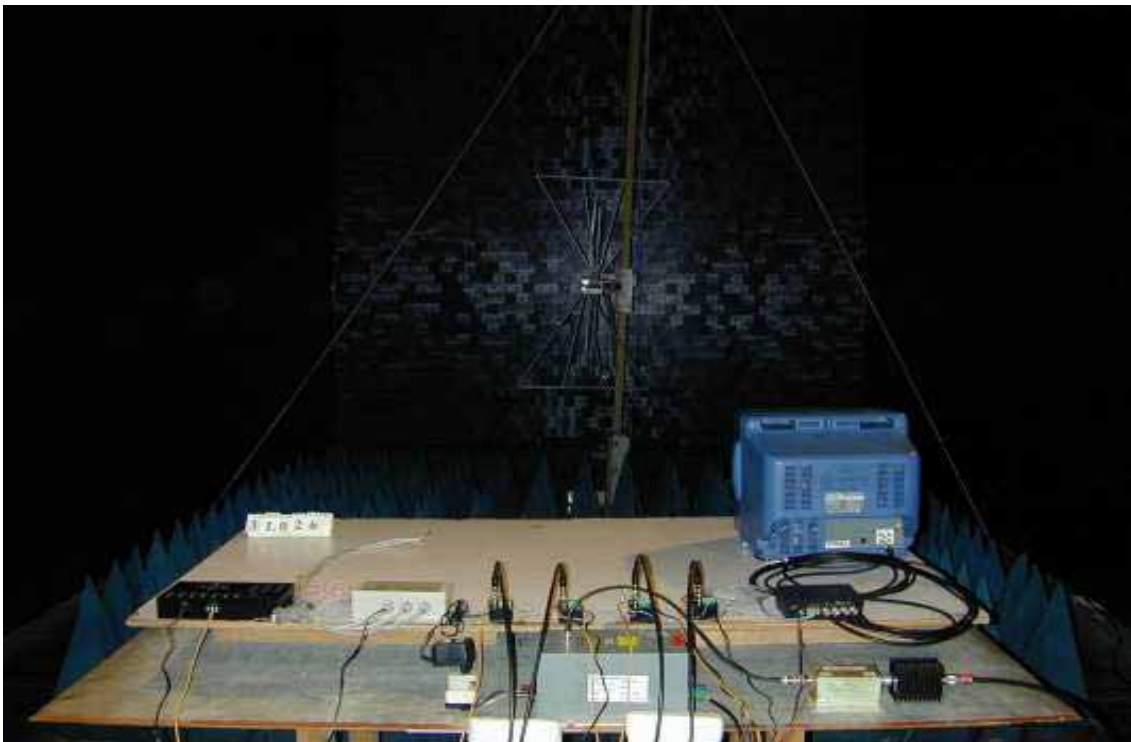



HomeTek Technology Inc.

## **Appendix B**

# **PHOTOS OF EUT**

### PHOTO OF EUT

Model : TTA111VT



Front View of EUT



Rear View of EUT

### PHOTO OF EUT

Model : TTA111VT

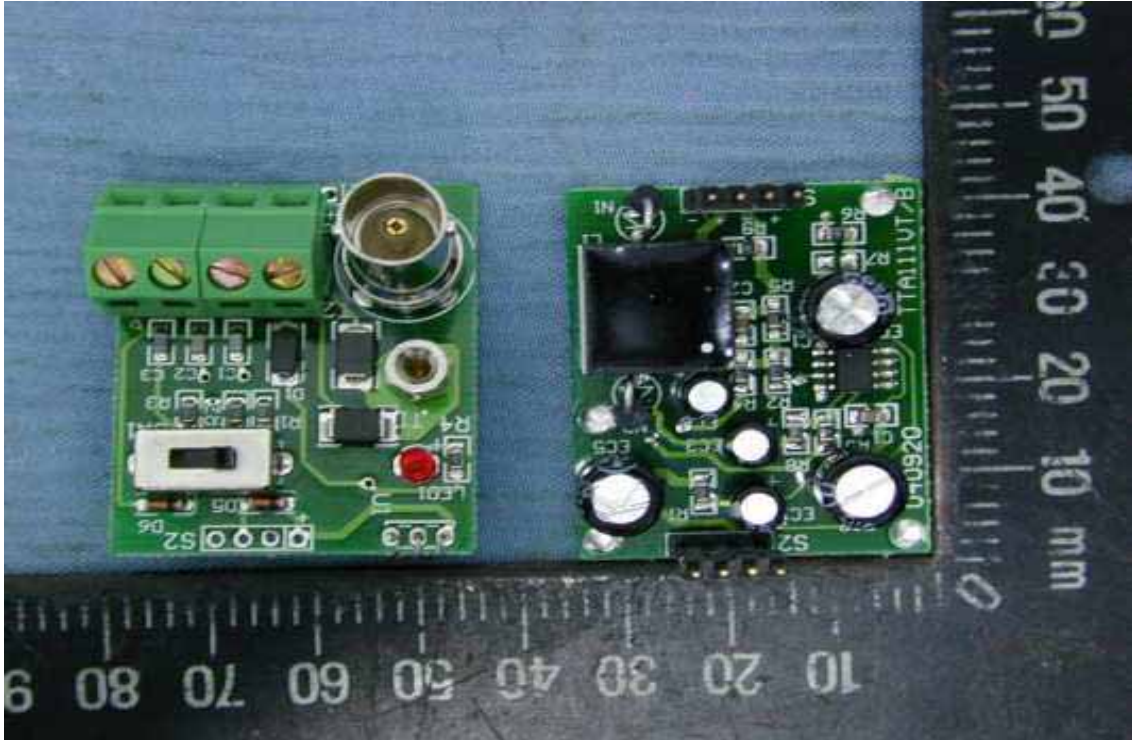

Component Side of Main Board

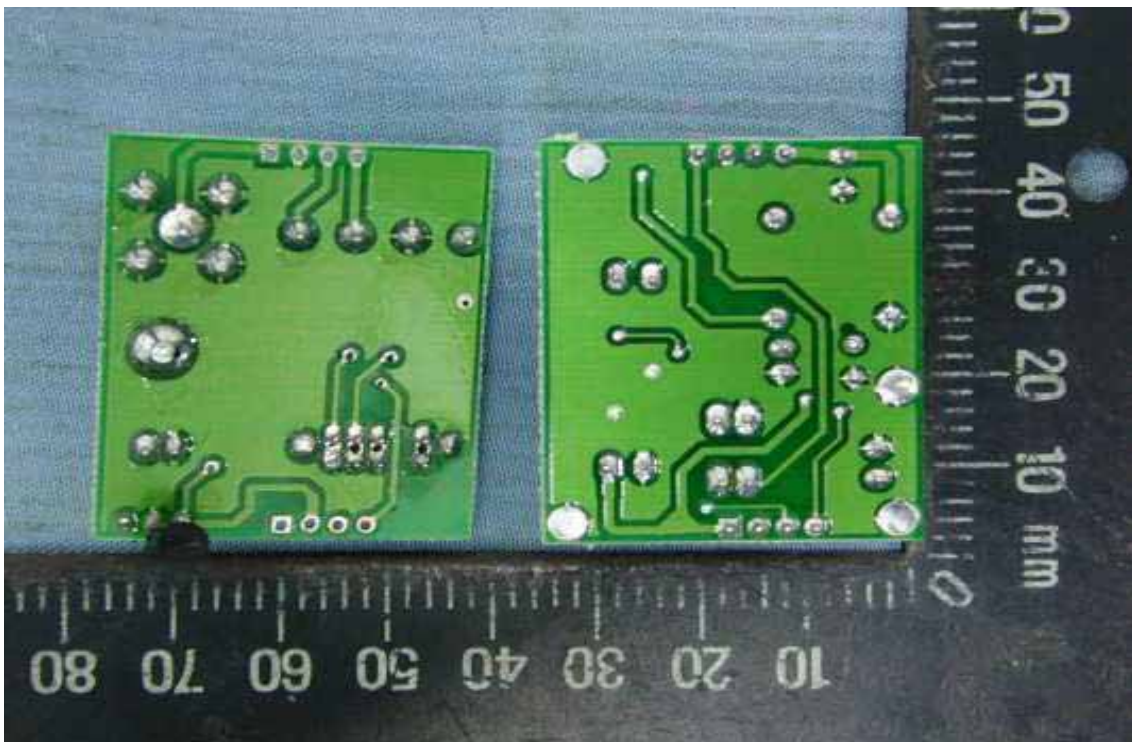

Solder Side of Main Board

### PHOTO OF EUT

Model : TTA111XXX



Front View of Adaptor



Rear View of Adaptor

### PHOTO OF EUT

Model : TTA111VT



Full View of I/O Port

# Declaration of Conformity

We(Manufacturer/Importer)

---

(company name)

---

(address)

declares under our sole responsibility that the product

Product name : Twisted Pair Transmission

Model No. : TTA111XXX

to which this declaration relates is in conformity with the following standard(s) or other normative document(s)

- |   |   |
|---|---|
| <input checked="" type="checkbox"/> EN 61000-6-3 (2001)     | <input checked="" type="checkbox"/> EN 50130-4 (1995)<br>+ A1 (1998)<br>+ A2 (2003) |
| <input checked="" type="checkbox"/> CISPR 22 Class B (1997) | <input checked="" type="checkbox"/> IEC 61000-4-2 (2001)                            |
| <input checked="" type="checkbox"/> EN 61000-3-2 (2000)     | <input checked="" type="checkbox"/> IEC 61000-4-3 (2002)                            |
| <input checked="" type="checkbox"/> EN 61000-3-3 (1995)     | <input checked="" type="checkbox"/> IEC 61000-4-4 (2004)                            |
| + A1 (2001)   | <input checked="" type="checkbox"/> IEC 61000-4-5 (2001)                            |
|   | <input checked="" type="checkbox"/> ENV 50141 (1993)                                |
|   | <input checked="" type="checkbox"/> IEC 61000-4-11 (2004)                           |

following the provisions of 2004/108/EC Directive

Place: \_\_\_\_\_ Signature: \_\_\_\_\_

Date : \_\_\_\_\_ Full name: \_\_\_\_\_



Title: \_\_\_\_\_

## EMC Laboratory Authorisation

Aut. No.: ELA 183

EMC Laboratory: **HomeTek Technology Inc.**  
**P.O.Box 13-131, Pan-Chiao City,**  
**No. 67-9, Shi-Men Rd., Tu-Chen City,**  
**Taipei Shien**  
**Taiwan R.O.C.**

Scope of  
Authorization: **All CENELEC standards [ENs] for EMC that are listed on the  
accompanying page, and, all of the corresponding CISPR,  
IEC, and ISO EMC standards that are listed on the  
accompanying page.**

Nemko has assessed the testing facilities, qualifications and testing practices and the relevant part of the organization. The above-mentioned EMC Laboratory has been validated against EN 45001 and ISO 17025 and found to be compliant. The laboratory also fulfils the conditions described in Nemko Document ELA-INFO-10. During Nemko's visit it was found that the EMC Laboratory is capable of performing tests within the Scope of Authorisation given on the accompanying page(s).

Accordingly, Nemko will accept test reports from the laboratory as a basis for attesting conformity to these EMC Standards under either the European Union EMC Directive (89/336/EEC) or, when applicable, the national standards of countries Nemko has been authorised to attest conformity with.

In order to maintain the Authorisation, the information given in the pertinent ELA-INFO-10 must be carefully followed. Nemko is to be promptly notified about any changes in the situation at the EMC Laboratory, which may affect the basis for this Authorisation. The Authorisation may be withdrawn at any time if the conditions are no longer considered to be fulfilled.

**The Authorisation is valid through 31 December 2004.**

Oslo, 28 November 2002

For Nemko AS:

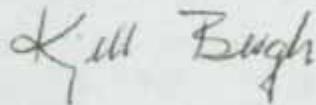

Kjell Bergh, Nemko Group EMC Co-ordinator

## EMC Laboratory Authorisation

Aut. No.: ELA 183

### SCOPE OF AUTHORIZATION

#### GENERIC & PRODUCT-FAMILY STANDARDS

EN 50081-1:1992 EN 61000-6-3: 2001 IEC 61000-6-3:1996 (mod)	EN 50082-1 :1997 EN 61000-6-1:2001 IEC 61000-6-1:1997 (mod)	EN 61000-6-2:1999 IEC 61000-6-2:1999 EN 61000-6-2: 2001 IEC 61000-6-2:1999 (mod)
EN 50081-2:1993 EN 61000-6-4 : 2001 IEC 61000-6-4:1997 (mod)	EN 55014-1:1993 + A1:1997 + A2 :1999 CISPR 14:1993 + A1:1996 + A2 :1998 EN 55014-1 :2000 + A1 :2001 CISPR 14-1 :2000 + A1 :2001	EN 55014-2:1997 CISPR 14-2:1997
EN 61000-3-2:1995 + A1:1998 + A2:1998 + A14 :2000 IEC 61000-3-2:1995 + A1:1997 + A2:1998 EN 61000-3-2 :2000 IEC 61000-3-2 :2000 (mod) + A1 :2001	EN 61000-3-3 :1995 + A1 :2001 IEC 61000-3-3 :1994 + A1 :2001  EN 61000-3-11 :00 IEC 61000-3-11 :00	EN 55022:1994 + A1:1995 + A2:1997 CISPR 22:1993 + A1:1995 + A2:1996  EN 55022:1998 + A1 :2000 CISPR 22:1997 + A1 :2000
EN 55024:1998 + A1 :2001 CISPR 24:1997 + A1 :2001	EN 50091-2:1995	EN 60945:1997 IEC 60945:1996
EN 55013: 1990 + A12 :1994 + A13 :1995 + A14 :1999 CISPR 13 :1975 + A1 :1983 (mod) EN55013: 2001 CISPR 13 : 2001 (mod)		

#### BASIC STANDARDS

EN 61000-4-2:1995 + A1:98 IEC 61000-4-2:1995 + A1:98 EN 60801-1:1993 IEC 801.2:1991 IEC 801.2:1984	EN 61000-4-3:1996 + A1:98 IEC 61000-4-3:1995 + A1:98 IEC 801.3:1984 ENV 50140:1993 + ENV 50204:1995	EN 61000-4-4:1995 IEC 61000-4-4:1995 IEC 801.4:1990
EN 61000-4-5:1995 IEC 61000-4-5:1995 ENV 50142:1994	EN 61000-4-6:1996 IEC 61000-4-6:1996 ENV 50141:1993	EN 61000-4-8:1993 IEC 61000-4-8:1993
EN 61000-4-11:1994 IEC 61000-4-11:1994		

Oslo, 28 November 2002

Kjell Bergh, Nemko Group EMC Co-ordinator

TÜV Rheinland Taiwan Ltd.



# Certificate of Appointment

for the applicant:

**Hometek Technology Inc.**  
No. 67-9, Shir Men Rd., Tu-Cheng City,  
Taipei Hsien 236, Taiwan, R.O.C.

has been authorized to carry out EMC tests by order and under supervision of TÜV Rheinland. It has successfully demonstrated capability to conduct measurement and to process test data according to:

**European and International EMC Standards as listed in the  
Scope of Authorization on the attachment to this certificate**

An assessment of the facility was conducted by TÜV Rheinland auditors according to the TÜV Rheinland requirements for "Test Site Approval" with reference to  
**ISO 17 025:1999**

**Certificate No. : 10012161-2004**

**Valid until : February 14, 2006**

TÜV Rheinland Taiwan Ltd.  
Taipei, December 21, 2004

  
Dipl.-Ing. Andreas Klinker  
Certification Body

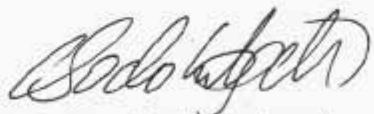
  
Dipl.-Ing. Bodo Kretschmar  
Product Safety and Quality



Attachment to  
**Certificate**  
of Appointment

SCOPE OF AUTHORIZATION

**Hometek Technology Inc.**  
No. 67-9, Shir Men Rd., Tu-Cheng City,  
Taipei Hsien 236, Taiwan, R.O.C.

**European Standards**

EN 50081-1	EN 61000-3-2	ENV 50140
EN 50081-2	EN 61000-3-3	ENV 50141
EN 50082-1	EN 61000-6-1	ENV 50204
EN 50130-4	EN 61000-6-2	
EN 50091-2	EN 61000-6-3	
EN 55011	EN 61000-6-4	
EN 55013	EN 61000-3-11	
EN 55014-1	EN 61000-4-2	
EN 55014-2	EN 61000-4-3	
EN 55022	EN 61000-4-4	
EN 55024	EN 61000-4-5	
EN 60601-1-2	EN 61000-4-6	
EN 60801	EN 61000-4-8	
EN 60945	EN 61000-4-11	
	EN 61204-3	

**International Standards**

CISPR 11	IEC 61000-4-2	IEC 61000-3-2
CISPR 13	IEC 61000-4-3	IEC 61000-3-3
CISPR 14-1	IEC 61000-4-4	IEC 61000-3-11
CISPR 14-2	IEC 61000-4-5	IEC 61000-6-1
CISPR 22	IEC 61000-4-6	IEC 61000-6-2
CISPR 24	IEC 61000-4-8	IEC 61000-6-3
	IEC 61000-4-11	IEC 61000-6-4
IEC 801.2	IEC 61000-4-12	IEC 60945
IEC 801.3		
IEC 801.4		

Certificate No. : 10012161-2004

Taipei, December 21 , 2004

Dipl.-Ing. Bodo Krätzschar  
Product Safety and Quality



TÜV Rheinland Taiwan Ltd.

# Certificate

of

# Appointment

for the applicant:

Hometek Technology Inc.  
No. 67-9, Shir Men Rd., Tu-Cheng City,  
Taipei Hsien 236, Taiwan, R.O.C.

has been authorized to carry out EMC tests by order and under supervision of TÜV Rheinland. It has successfully demonstrated capability to conduct measurement and to process test data according to:

**European and International EMC Standards as listed in the  
Scope of Authorization on the attachment to this certificate**

An assessment of the facility was conducted by TÜV Rheinland auditors according to the TÜV Rheinland requirements for "Test Site Approval" with reference to

**ISO 17 025:1999**

Certificate No. : 10012161-2006

Valid until : June 14, 2007

TÜV Rheinland Taiwan Ltd.  
Taipei, April 13, 2006

  
Dipl.-Ing. Andreas Klinker  
Certification Body

  
Dipl.-Ing. Bodo Kretzschmar  
Product Safety and Quality



Attachment to  
**Certificate**  
of Appointment

SCOPE OF AUTHORIZATION

Hometek Technology Inc.  
No. 67-9, Shir Men Rd., Tu-Cheng City,  
Taipei Hsien 236, Taiwan, R.O.C.

**European Standards**

EN 50081-1	EN 61000-3-2	ENV 50140
EN 50081-2	EN 61000-3-3	ENV 50141
EN 50082-1	EN 61000-6-1	ENV 50204
EN 50130-4	EN 61000-6-2	
EN 50091-2	EN 61000-6-3	
EN 55011	EN 61000-6-4	
EN 55013	EN 61000-3-11	
EN 55014-1	EN 61000-4-2	
EN 55014-2	EN 61000-4-3	
EN 55022	EN 61000-4-4	
EN 55024	EN 61000-4-5	
EN 60601-1-2	EN 61000-4-6	
EN 60801	EN 61000-4-8	
EN 60945	EN 61000-4-11	
	EN 61204-3	

**International Standards**

CISPR 11	IEC 61000-4-2	IEC 61000-3-2
CISPR 13	IEC 61000-4-3	IEC 61000-3-3
CISPR 14-1	IEC 61000-4-4	IEC 61000-3-11
CISPR 14-2	IEC 61000-4-5	IEC 61000-6-1
CISPR 22	IEC 61000-4-6	IEC 61000-6-2
CISPR 24	IEC 61000-4-8	IEC 61000-6-3
	IEC 61000-4-11	IEC 61000-6-4
IEC 801.2	IEC 61000-4-12	IEC 60945
IEC 801.3		
IEC 801.4		

Certificate No. : 10012161-2006

Taipei, April 13, 2006

  
Dipl.-Ing. Bodo Kretzschmar  
Product Safety and Quality



TÜV Rheinland Taiwan Ltd.

# Certificate of Appointment

for the applicant:

**Hometek Technology Inc.**  
**No. 67-9, Shir Men Rd., Tu-Cheng City,**  
**Taipei Hsien 236, Taiwan, R.O.C.**

has been authorized to carry out EMC tests by order and under supervision of TÜV Rheinland. It has successfully demonstrated capability to conduct measurement and to process test data according to:

**European and International EMC Standards as listed in the  
Scope of Authorization on the attachment to this certificate**

An assessment of the facility was conducted by TÜV Rheinland auditors according to the TÜV Rheinland requirements for "Test Site Approval" with reference to  
**ISO 17025: 2005**

**Certificate No. : 10012161-2007**

**Valid until : Sept. 7, 2008**

TÜV Rheinland Taiwan Ltd.  
Taipei, June 20, 2007

  
Dipl.-Ing. Andreas Klinker  
Certification Body

  
Dipl.-Ing. Bodo Kretzschmar  
Product Safety and Quality



Attachment to  
**Certificate**  
of Appointment

SCOPE OF AUTHORIZATION

**Hometek Technology Inc.**  
No. 67-9, Shir Men Rd., Tu-Cheng City,  
Taipei Hsien 236, Taiwan, R.O.C.

**European Standards**

EN 50081-1	EN 61000-3-3	ENV 50140
EN 50081-2	EN 61000-6-1	ENV 50141
EN 50082-1	EN 61000-6-2	ENV 50204
EN 50130-4	EN 61000-6-3	
EN 50091-2	EN 61000-6-4	
EN 55011	EN 61000-3-11	
EN 55013	EN 61000-4-2	
EN 55014-1	EN 61000-4-3	
EN 55014-2	EN 61000-4-4	
EN 55022	EN 61000-4-5	
EN 55024	EN 61000-4-6	
EN 60601-1-2	EN 61000-4-8	
EN 60801	EN 61000-4-11	
EN 60945	EN 61204-3	
EN 61000-3-2	EN 62040-2	

**International Standards**

CISPR 11	IEC 61000-4-2	IEC 61000-3-2
CISPR 13	IEC 61000-4-3	IEC 61000-3-3
CISPR 14-1	IEC 61000-4-4	IEC 61000-3-11
CISPR 14-2	IEC 61000-4-5	IEC 61000-6-1
CISPR 22	IEC 61000-4-6	IEC 61000-6-2
CISPR 24	IEC 61000-4-8	IEC 61000-6-3
	IEC 61000-4-11	IEC 61000-6-4
IEC 801.2	IEC 61000-4-12	IEC 60945
IEC 801.3		IEC 62040-2
IEC 801.4		

**Certificate No. : 10012161-2007**

Taipei, June 20, 2007

  
Dipl.-Ing. Bodo Kretzschmar  
Product Safety and Quality