

REVISIONS	
ISS	SYMBOL DESCRIPTION\DATE

REMARK: RoHS COMPLIANT  
(符合 RoHS)

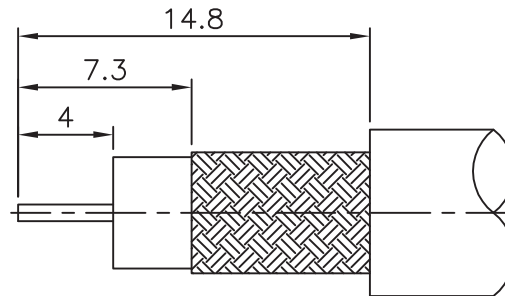
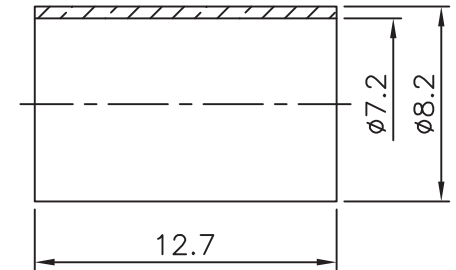
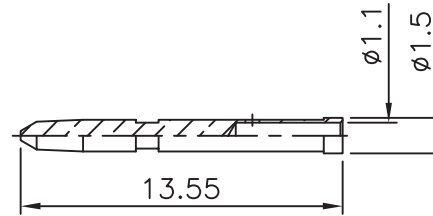
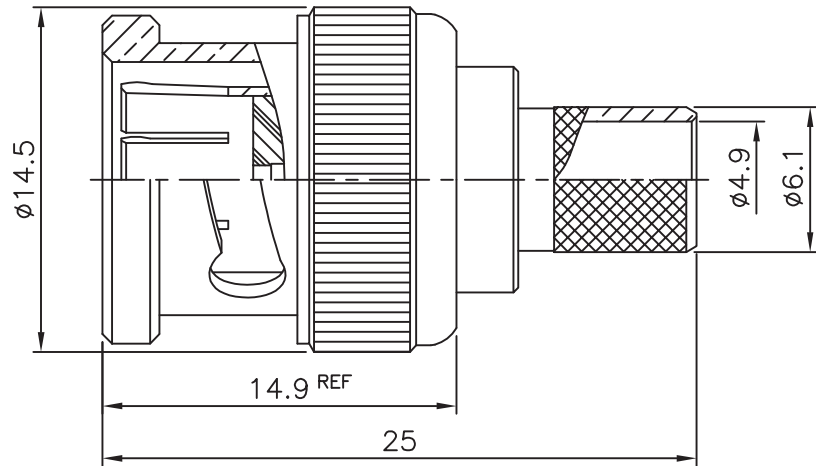

NOTES: FINISH (PLATING THICKNESS IN MICRO-INCHES)

- BRASS PER QQ-B-626
- NICKEL PL 70 MIN THICK OVER COPPER STRIKE
- GOLD PL 3 MIN OVER NICKEL PL 70 MIN THICK OVER COPPER STRIKE
- TEFLON MIL-P-19468
- BRASS JIS H 3250, C 2700

RECOMMENDED  
CABLE STRIPPING DIM'S  
(建議剝線尺寸)

- CRIMPED FERRULE  
HEX CRIMP SIZE .278" (7.06mm)  
(套管壓著工具)
- CRIMPED CONTACT PIN  
SQ CRIMP SIZE .042" (1.07mm)  
(中心針壓著工具)

FERRULE	NOTE 5	NOTE 2			
CONTACT PIN	NOTE 1	NOTE 3			
SHELL	NOTE 1	NOTE 2			
GASKET	SILICONE	RED			
C RING	SS41	NOTE 2			
SPRING	SK5	NOTE 2			
WASHER	SS41	NOTE 2			
INSULATOR	NOTE 4	WHITE			
BODY	NOTE 1	NOTE 2			
NO.	DESCRIPTION	MATERIAL	FINISH	Q'TY	DRAWING NO.

DIMENSIONS ARE IN MILLIMETERS			
UNLESS OTHERWISE SPECIFIED TOLERANCES (一般公差)			
0.5~6	= ±0.2		
>6~30	= ±0.4		
>30~120	= ±0.6		
>120~315	= ±1		
>315~1000	= ±1.6		
ANGLES(角度) = ±5°			
SCALE	3/1	ISSUE	A1

PART NO.	
APPROVED	DATE
	09/08/10'
CHECKED	DATE
	09/08/10'
DRAWN	DATE
	09/08/10'

TITLE	BNC CRIMP PLUG (75 ohms)
DRAWING NO.	
FILE NO.	