

19" 3U Rack Card Series: VGA & Stereo Audio CAT5 Distribution System – Multi Input/Output

ITEM NO.: RB01, RV01, RT01

RV01, RT01 are 19" rack cards installed at local side for sending VGA & Stereo audio over cost effective CAT5 solution to remote side. These rack cards could install in RB01 19" standard rack mounting cabinet, up to 15 pieces. These senders with rack card type is a smart, fast and cost-effective, eliminates costly and bulky VGA and Audio cable and the most efficient way to move multimedia content from player to display. At monitor remote side, to use CAT5 VGA & Stereo audio CAT5 receiver for each monitor. It is professional and neat application for shopping malls, public address systems, airports, train & bus station, boardrooms, trade shows, computer based training application.

VGA & Audio Card

RB01 3U 19" Rack Mounting Cabinet

- Standard 19" 3U rack mounting cabinet.
- **Allow to insert 15 rack cards (RV01, RT01).**
- **Built in 1000W switching power supply (+5V 10Amp, -5V 10Amp).**
- Built in fan for low operating temperature.
- Ideal for multi input/output VGA/component video, stereo/digital audio distribution. Perfect for used in shopping malls, public address systems, airports, train & bus station, boardrooms, trade shows, computer based training application.



RV01 1 Channel VGA & Stereo/Digital Audio Input Rack Card

- 19" rack card with one VGA & stereo audio input and one loop output.
- Loop out could be for local monitoring or daisy chain application.
- **Automatic identify digital or analog audio input.**
- **Audio output could be digital or analog conversion. (Digital audio only support PCM format).**
- **Support DDC and built in EDID, backup monitor EDID function.**
- Maximum supports up to 4 channel VGA & stereo/digital audio input cards (RV01x 4 pieces) in one RB01 rack mounting cabinet.
- Each input could allow multi outputs via RT01 (5 Channel CAT5 output rack card).
- Used to work with RT01 CAT5 5 channel transmitter rack card for multi input/output distribution over CAT5 cable.



RT01 5 Channel CAT5 VGA/Component & Audio Output Rack Card

- 19" rack card with 5 Channel CAT5 output as a CAT5 transmitter, to extend VGA/Component Video & audio over one CAT5 cable.
- Remote monitoring side using CAT5 receiver box, such a VE02ALR, VE02DALS.
- VGA resolution support up to 1600 x 1200@85Hz.
- Component video support Full HD 1080p.
- Long range transmission up to 300 meters (Max.)
- 4 input signal option with LED indication.
- Automatic scan each channel.
- Allow up to 14 pieces RT01 CAT5 transmitter card at RB01, to send multi distribution up to 70 remote monitors.



Rack Card Install to Rack Card Cabinet:

1. Put the Rack card into cabinet, then screw A and A'.
2. The unit must cooperate with cabinet RB01.
3. When video signal input, signal detector LED will light, if no function, please check cable connection.

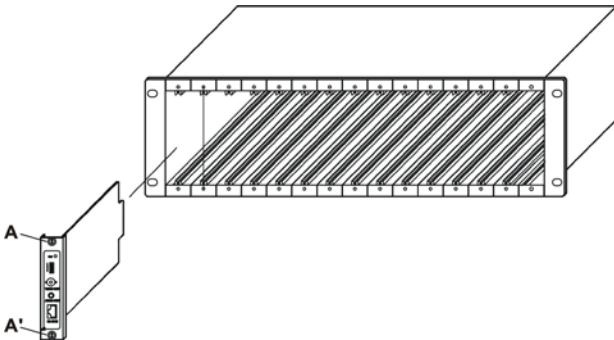

RB01 Setting:

LED indication: Power on/off at back side of RB01 3U 19" Rack Mounting Cabinet

Rack Card model:

Rack Card Series: RV01, RT01

RV01 Setting:

After setup rotary switch, then insert into RB01 rack cabinet. (Hot pluggable)

Rotary Dip Switch Define:

- 0: Setup EDID from VGA Loop out terminal monitor and remove built in Monitor EDID.
- 5: Setup EDID from RV01 built in standard monitor EDID.
(Resolution: 1600x1200@60Hz)
- 6: Setup EDID from RV01 built in wide screen monitor EDID.
(Resolution: 1680x1050@60Hz)
- 7: Setup EDID from RV01 backup monitor EDID and backup EDID from VGA Loop out

terminal monitor

- 1: Setup CH1 output.
- 2: Setup CH2 output.
- 3: Setup CH3 output.
- 4: Setup CH4 output.

Set up EDID Mode:

Choose EDID mode(rotary dip switch 0, 5, 6, 7), insert RV01 into RB01 rack cabinet and wait LED on to finish setup.
 (Recommend not to connect VGA cable under EDID set up MODE)

Backup MONITOR EDID:

Rotary dip switch set up at "7", then insert into RB01 rack cabinet; connect monitor to loop out VGA terminal to start backup, the all 1,2,3,4 LED will be on until finish EDID backup with " 3 & 4 "LED on only.
 (Recommend not to connect VGA cable under backup EDID)

Input channel option:

Choose input channel (rotary dip switch 1, 2, 3, 4), then insert into RB01 rack cabinet.

Dip Switch Define:

- 1 ↓ = Auto identify digital or analog audio input.
 ↑ = Setup digital audio input.

- 2 ↓ = Audio Loop Out as normal mode.
 ↑ = Audio Loop Out as special mode. (Ref. to below chart)

DIP SW 2	Audio In	Audio Out
↓	Analog Audio	Analog Audio
↓	Digital Audio	Digital Audio
↑	Analog Audio	Digital Audio ※ 1
↑	Digital Audio	Analog Audio ※ 2

- ※ 1 Output mode 48K / 16 Bit PCM.
- ※ 2 Only Support PCM decoder output.

LED Indication:

- 1 2 3 4 ■ = OFF □ = ON ☆ = FLASH
- ■ ■ ■ 4 LED OFF: finish "0" setup and off output.
 - □ □ □ 4 LED ON: system is under setup mode.
 - ■ ■ ■ one LED ON only: input channel
 - ☆ ■ ■ ■ one LED FLASH: no signal input at this channel
 (based on vertical SYNC signal).

 - ■ ■ □ ON 1 & 4: finish "5" setup.
 - □ ■ □ ON 2 & 4: finish "6" setup.
 - ■ □ □ ON 3 & 4: finish "7" setup.
 - ☆☆☆☆ 4 LED FLASH: wrong setup, please reset.

Caution:

To avoid signal conflict with other input card, the card can not setup the channel already used at other input card.

RT01 Setting:

After setup rotary switch, then insert into RB01 rack cabinet. (Hot pluggable)

Rotary Dip Switch Define:

- 0: Off output.
- 1: Setup CH1 input.
- 2: Setup CH2 input.
- 3: Setup CH3 input.
- 4: Setup CH4 input.
- 5: Auto selection CH1 or CH2 input.
- 6: Auto selection CH3 or CH4 input.
- 7: Auto selection CH1 or CH4 input.

LED Indication:

- 1 2 3 4 ■ = OFF □ = ON ☆ = FLASH
- 4 LED OFF: finish "0" setup and off output.
- 4 LED ON: system is under setup mode.
- one LED ON only: input channel
- ☆■■■ one LED FLASH: no signal input at this channel
(Based on vertical SYNC signal).

RJ45 Define:

Link Cable (TIA/EIA-568-B)

No.	Color	Signal
1.	Orange-white	Video Red+
2.	Orange	Video Red-
3.	Green-white	Video Green+
4.	Blue	Digital Audio-
5.	Blue-white	Digital Audio+
6.	Green	Video Green-
7.	Brown-white	Video Blue+
8.	Brown	Video Blue-

Optional Model:

Rack Series: RB01, RV01.

VGA Series: VE01R (no audio), VE02ALR, VE02DAR, VE02DALS.

Cable:

Video Link cable using hi quality CAT5E UTP/STP or CAT6 UTP cable.

Please noted STP cable could enhance noise rejection, but also less transmission range and picture sharpness quality.

Caution:

The cabling must away from any equipment with electromagnetic wave, i.e.: microwave, radio equipment, high voltage lines.

View of Installation:

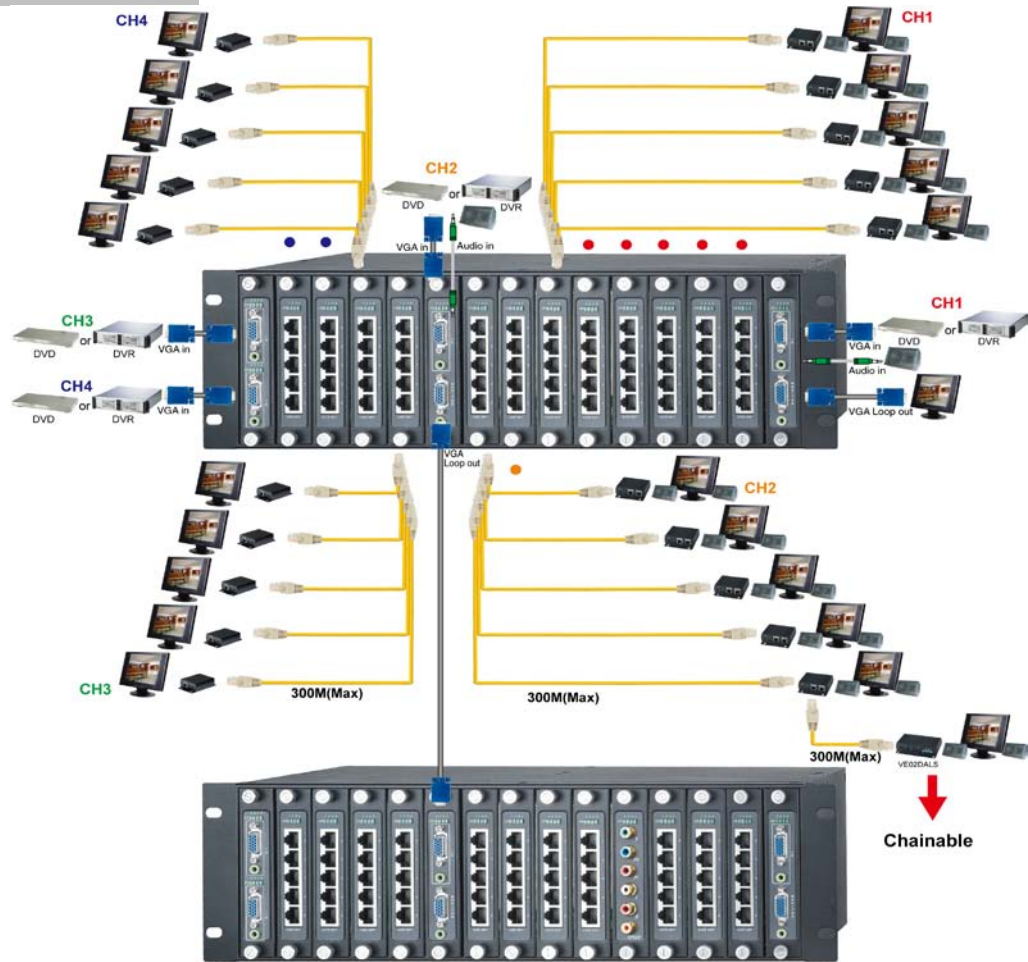

Option Model: – CAT5 Receiver at Remote Site:

VE02ALR VGA & Stereo Audio CAT5 Receiver– Chainable function

- Work with VE02ALT, VE02ALR as receiver for extra remote VGA display equipment.
- It could be daisy chained for another VE02ALR to extended working range over 300 meters and multiple displays.
- Built in equalization, gain adjustment.
- Supports up to 1600x1200 @85Hz.



VE02DALS VGA & Stereo Audio, Digital Audio CAT5 Receiver– Built in Skew Adjustment

- Identical to the above VE02ALR receiver, but built in RGB skew corrector for the optimum video performance under long cable run.
- Built in digital audio output (coaxial, optical)



Specification:

ITEM NO.	RB01
Slot for Rack Card	15 pieces
Power Input	100VAC ~ 240VAC / 50 ~ 60Hz
Power Output	1000W / +5VDC 10A / -5VDC 10A
Fan	8cm / 3100rpm
Material	Metal
Dimensions mm	482x205x133 (3U)
Weight g	5000

ITEM NO.	RV01
Video Input / Output	DB15 x 2 (R.G.B 1Vpp 75Ω · H.V Sync TTL)
Video Bandwidth	400MHz (Loop Out 750MHz -3dB)
Audio Input / Output	Stereo 3.5 Phone Jack (Analog 3Vpp, 10KΩ, Digital 75Ω)
Analog Audio Bandwidth	20 - 20KHz
Digital Audio Resolution	16Bit / 48K PCM (AC3, DTS Bypass Through)
Power Consumption	200mA
Dimensions mm	125x125x27.5 mm
Weight g	115

ITEM NO.	RT01
Video Resolution (Max)	VGA 1600x1200 @85Hz, YUV 1080p
Video Bandwidth	350MHz -3dB
Audio Support	SPDIF
Power Consumption	400mA
Dimensions mm	125x125x27.5 mm
Weight g	120

ITEM NO.	VE02ALR	VE02DALS
Resolution	Up to 1600 x 1200 non-interlaced to 85 Hz	
Video Bandwidth	150MHz	122MHz(-3dB)
Video Output	RGB Analog, 75Ω, 0.7Vp-p	RGB Analog, 75Ω, 1Vp-p
Sync Output	H/V Separated, 5V TTL	
Horizontal Frequency	30-95 KHz	
Vertical Frequency	50-180 Hz	
VGA Connector	DB15 x 1	
Analog Audio Output	Analog audio: 3.5mm Stereo Phone jack 10KΩ, 3Vp-p (Max)	Analog audio: 3.5mm Stereo Phone jack 10KΩ, 3Vp-p (Max) Digital audio: Optical x 1, RCA x 1
Analog Audio Bandwidth	20-20KHz (-3dB)	
Skew Adjustment	X	0 – 62ns (2ns Step)
Link Connector	RJ45 x 1	
Max Distance	Up to 1000 ft. (300M)	
Power Supply	DC 5V 2000mA	
Power Consumption	700mA (Max)	1000mA (Max)
Dimensions (mm)	88 x 95 x 30	125 x 95 x 30
Weight (g)	205	285



Rev.B